

# TSI-2 2k x 2k Time-Slot Interchanger

## 1 Introduction

This document consists of two major sections:

- The TTSI002081 device hardware description. This section contains ball information, operating conditions, dc electrical characteristics, timing diagrams, ac characteristics, and packaging information.
- The TTSI002081 device register description. This section contains register information.

### 1.1 Related Documents

The documentation package for this device consists of the following documents:

- The *TSI-2 2k x 2k Time-Slot Interchanger Product Brief*, the *TSI Family Selection Guide*, the *TSI-2 2k x 2k Time-Slot Interchanger Data Sheet* (this document), and the *TTSI-144 Scalable Time-Slot Interchanger System Design Guide*.

These documents are available on the public website shown below.

If the reader displays this document using *Acrobat Reader*®, clicking on any blue text will bring the reader to that reference point.

To access related documents, including the documents mentioned above, please go to the following public website, or contact your Agere representative (see the last page of this document).

[http://www.agere.com/telecom/time\\_slot\\_interchangers.html](http://www.agere.com/telecom/time_slot_interchangers.html)

### 1.2 Block Diagram and High-Level Interface Definition

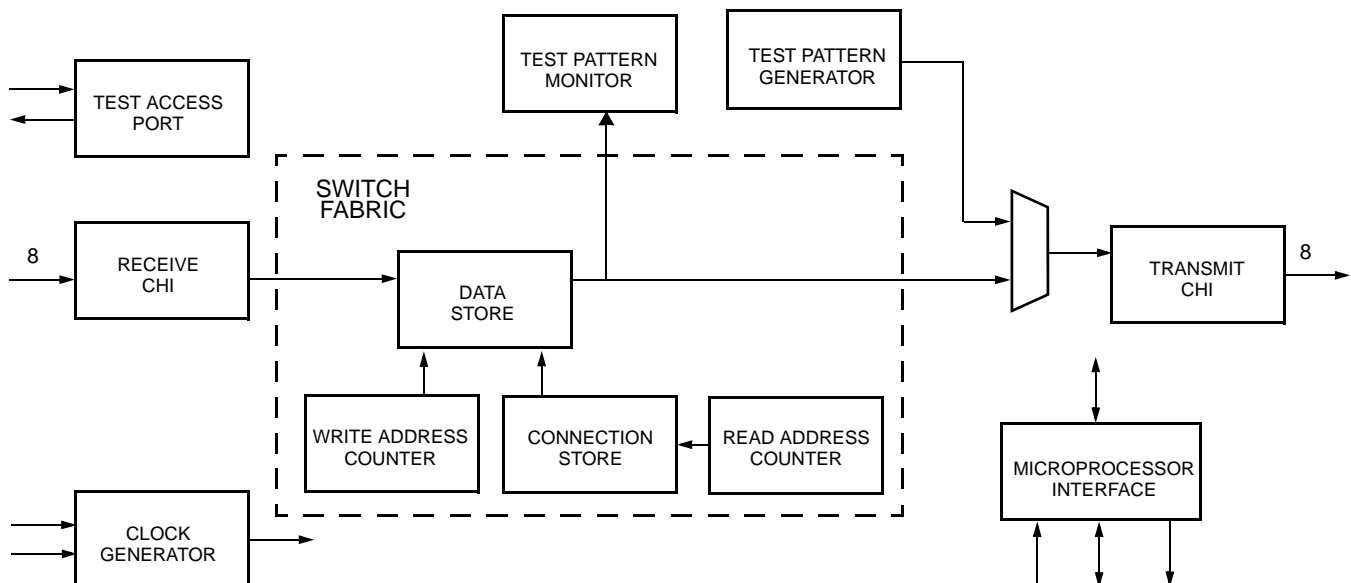

Figure 1-1. Block Diagram and High-Level Interface Definition

## Table of Contents

Contents	Page
1 Introduction .....	1
1.1 Related Documents .....	1
1.2 Block Diagram and High-Level Interface Definition .....	1
2 Ball Information .....	7
2.1 Top View Ball Diagram .....	7
2.2 Package Ball Assignments .....	8
2.3 Package Ball Matrix .....	10
2.3.1 Top View .....	10
2.3.2 Bottom View .....	11
2.4 Ball Types .....	12
2.5 Ball Definitions .....	12
3 Operating Conditions and Reliability .....	15
3.1 Absolute Maximum Ratings .....	15
3.2 Recommended Operating Conditions .....	15
3.3 Handling Precautions .....	15
3.4 Thermal Parameters (Definitions and Values) .....	16
3.5 Power Consumption .....	17
4 dc Electrical Characteristics .....	18
5 Timing Diagrams and ac Characteristics .....	19
6 Register Description .....	31
6.1 Device Addressing Notes .....	31
6.2 Acronyms Used .....	31
6.3 Address Map .....	31
6.4 Register Summary .....	32
6.5 Global Control Registers .....	34
6.6 Connection Store Generator Registers .....	39
6.7 Test Pattern Generator and Monitor Registers .....	44
6.8 Concentration Highway Configuration Registers .....	48
7 Switch Fabric Control .....	54
8 Connection Store .....	58
9 Outline Diagrams .....	60
10 Ordering Information .....	61

Table of Contents (continued)

Contents	Page
Table 2-1. Package Ball Assignments in Signal Name Order.....	8
Table 2-2. Package Ball Assignments (Top View) .....	10
Table 2-3. Package Ball Assignments (Bottom View).....	11
Table 2-4. Ball Types .....	12
Table 2-5. Timing Port .....	12
Table 2-6. Transmit and Receive Concentration Highways .....	12
Table 2-7. Control Port.....	13
Table 2-8. Initialization and Test Access.....	13
Table 2-9. Power Balls.....	14
Table 3-1. Absolute Maximum Ratings .....	15
Table 3-2. Operating Conditions .....	15
Table 3-3. ESD Tolerance.....	15
Table 3-4. Thermal Parameter Values .....	16
Table 3-5. Power Consumption .....	17
Table 4-1. CMOS Inputs .....	18
Table 4-2. CMOS Outputs .....	18
Table 4-3. CMOS Bidirectionals (DATA[15:0]) .....	18
Table 5-1. CHICLK Timing Specifications.....	19
Table 5-2. MPUCLK Timing Specifications .....	19
Table 5-3. ac Timing Measurement Specification .....	20
Table 5-4. CHI Interface Timing.....	21
Table 5-5. CHI 3-State Output Control.....	27
Table 5-6. Microprocessor Port Timing—Read Cycle.....	28
Table 5-7. Microprocessor Port Timing—Write Cycle .....	29
Table 6-1. Address Map.....	31
Table 6-2. Global Registers .....	32
Table 6-3. Connection Store Generator Registers.....	32
Table 6-4. Test Pattern Generator and Monitor Registers .....	33
Table 6-5. Concentration Highway Configuration Registers .....	33
Table 6-6. Switch Fabric Control.....	33
Table 6-7. Connection Store .....	34
Table 6-8. Reserved Registers .....	34
Table 6-9. Version_Control (Read Only).....	34
Table 6-10. Chip_Identity (Read Only) .....	34
Table 6-11. Summary_Interrupt_Status (Read Only).....	35
Table 6-12. Summary_Interrupt_Mask (Read/Write).....	35
Table 6-13. CPU_Access_Error (CORWN) .....	36
Table 6-14. CPU_Access_Error_Mask (Read/Write).....	36
Table 6-15. Global_Control (Read/Write) .....	37
Table 6-16. PLL_Control (Read/Write) .....	38
Table 6-17. Power_Control (Read/Write).....	38
Table 6-18. Invalid_Address_Trap (Read Only).....	38
Table 6-19. Scratch_Register (Read/Write).....	38
Table 6-20. Reserved_0 (Read/Write) .....	39
Table 6-21. CSG_Control (Read/Write) .....	39
Table 6-22. CSG_Status (Read Only).....	40
Table 6-23. CSG_Starting_Address (Read/Write) .....	40
Table 6-24. CSG_Ending_Address (Read/Write) .....	40
Table 6-25. CSG_Write_Enable_Low (Read/Write).....	40
Table 6-26. CSG_Write_Enable_High (Read/Write).....	40
Table 6-27. CSG_Seed_Low (Read/Write).....	41
Table 6-28. CSG_Seed_High (Read/Write).....	41

Table of Contents (continued)

Tables	Page
Table 6-29. CSG_OR_Mask_Low (Read/Write) .....	41
Table 6-30. CSG_OR_Mask_High (Read/Write) .....	41
Table 6-31. CSG_AND_Mask_Low (Read/Write) .....	42
Table 6-32. CSG_AND_Mask_High (Read/Write) .....	42
Table 6-33. CS_Stream_Control (Read/Write) .....	42
Table 6-34. CSG_Configuration (Read/Write) .....	43
Table 6-35. TPG_Configuration (Read/Write) .....	44
Table 6-36. TPG_User_Pattern (Read/Write) .....	44
Table 6-37. TPM_Configuration (Read/Write) .....	45
Table 6-38. TPM_User_Pattern (Read/Write) .....	45
Table 6-39. TPM_Error_Count (Sat/Roll*) .....	46
Table 6-40. TPG_Inject_Error_Count (Write Only) .....	46
Table 6-41. TPG_Data_Invert_Mask (Read/Write) .....	46
Table 6-42. TPM_Status (Read Only) .....	47
Table 6-43. TPM_Status_Mask (Read/Write) .....	47
Table 6-44. Receive_CHI_Configuration (Read/Write) .....	48
Table 6-45. Receive_CHI_Status (CORWN) Receive_CHI_Status (CORWN) .....	48
Table 6-46. Receive_CHI_Status_Mask (Read/Write) .....	49
Table 6-47. Receive_CHI_Global_Configuration (Read/Write) .....	49
Table 6-48. Transmit_CHI_Configuration (Read/Write) .....	50
Table 6-49. Transmit_CHI_Status (CORWN) .....	51
Table 6-50. Transmit_CHI_Status_Mask (Read/Write) .....	51
Table 6-51. Transmit_CHI_Global_Configuration (Read/Write) .....	52
Table 6-52. Receive_CHI_Time_Slot_Offset (Read/Write) .....	53
Table 6-53. Transmit_CHI_Time_Slot_Offset (Read/Write) .....	53
Table 7-1. SF_Status (CORWN) .....	54
Table 7-2. SF_Status_Mask (Read/Write) .....	54
Table 7-3. Data_Store_Time_Slot_Capture_Select (Read/Write) .....	55
Table 7-4. Data_Store_Captured_Data (Read Only) .....	55
Table 7-5. Connection_Store_Parity_Error_Address_Trap (CORWN) .....	56
Table 7-6. Receive_Link_Offset (Read Only) .....	56
Table 7-7. Transmit_Link_Offset (Read/Write) .....	56
Table 7-8. Wide_Mode_Control (Read/Write) .....	57
Table 8-1. Low_Control_Word (Read/Write) .....	58
Table 8-2. High_Control_Word (Read/Write) .....	59

**Table of Contents** (continued)

<b>Figures</b>	<b>Page</b>
Figure 1-1. Block Diagram and High-Level Interface Definition.....	1
Figure 2-1. Package Diagram (Top View) .....	7
Figure 5-1. CHICLK Timing Specifications .....	19
Figure 5-2. MPUCLK Timing Specifications .....	19
Figure 5-3. ac Timing Measurement Specification .....	20
Figure 5-4. CHI Interface Timing .....	21
Figure 5-5. Typical Receive CHI Timing with 16.384 Mbits/s Data and 16.384 MHz CHICLK.....	22
Figure 5-6. Transmit CHI Timing with 16.384 Mbits/s Data and 16.384 MHz CHICLK .....	22
Figure 5-7. Typical Receive CHI Timing with 8.192 Mbits/s Data and 16.384 MHz CHICLK.....	23
Figure 5-8. Transmit CHI Timing with 8.192 Mbits/s Data and 16.384 MHz CHICLK .....	23
Figure 5-9. Typical Receive CHI Timing with 4.096 Mbits/s Data and 16.384 MHz CHICLK.....	24
Figure 5-10. Transmit CHI Timing with 4.096 Mbits/s Data and 16.384 MHz CHICLK .....	24
Figure 5-11. Typical Receive CHI Timing with 2.048 Mbits/s Data and 16.384 MHz CHICLK.....	25
Figure 5-12. Transmit CHI Timing with 2.048 Mbits/s Data and 16.384 MHz CHICLK .....	25
Figure 5-13. Typical Receive CHI Timing with 8.192 Mbits/s Data and 8.192 MHz CHICLK.....	26
Figure 5-14. Transmit CHI Timing with 8.192 Mbits/s Data and 8.192 MHz CHICLK .....	26
Figure 5-15. CHI 3-State Output Control .....	27
Figure 5-16. Microprocessor Port Timing—Read Cycle .....	28
Figure 5-17. Microprocessor Port Timing—Write Cycle .....	29
Figure 6-1. Transmit CHI Configuration (R/W) .....	50

## **Hardware Description**

## 2 Ball Information

### 2.1 Top View Ball Diagram

The device is housed in a 240-ball plastic ball grid array. Figure 2-1 shows the ball arrangement viewed from the top of the package. The balls are spaced on a 1.0 mm pitch.

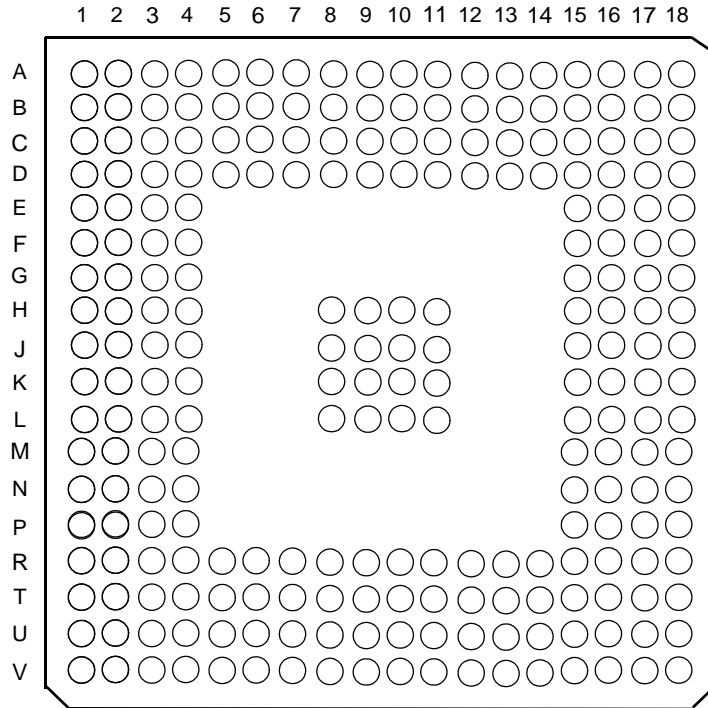

Figure 2-1. Package Diagram (Top View)

## 2.2 Package Ball Assignments

Table 2-1. Package Ball Assignments in Signal Name Order

Symbol	Ball	Symbol	Ball	Symbol	Ball	Symbol	Ball	Symbol	Ball
ADDR00	A17	DATA13	P18	NC	V7	NC	F1	VDD15	D13
ADDR01	A16	DATA14	P17	NC	T8	NC	G3	VDD15	D14
ADDR02	A15	DATA15	P16	NC	U8	NC	G2	VDD15	G4
ADDR03	A14	$\overline{DT}$	H17	NC	V8	NC	G1	VDD15	H4
ADDR04	A13	FSYNC	T11	NC	U9	NC	H2	VDD15	L4
ADDR05	A12	$\overline{HIZ}$	R17	NC	V9	NC	H1	VDD15	M4
ADDR06	A11	$\overline{INT}$	H16	NC	V10	NC	J2	VDD15	R7
ADDR07	A10	MPUCLK	K15	NC	U10	NC	J1	VDD15	R8
ADDR08	A9	PAR0	R18	NC	V11	NC	K1	VDD15	R11
ADDR09	A8	PAR1	P15	NC	U11	NC	K2	VDD15	R12
ADDR10	A7	$\overline{R/W}$	J17	NC	V12	NC	L1	VDD33	C9
ADDR11	A6	$\overline{RESET}$	H15	NC	U12	NC	L2	VDD33	C10
ADDR12	A5	RSV1	F17	NC	V13	NC	M1	VDD33	C17
ADDR13	A4	RSV2	F18	NC	U13	NC	M2	VDD33	D9
ADDR14	A3	RSV3	E15	NC	V14	NC	N1	VDD33	D10
ADDR15	A2	RSV4	E16	NC	U14	NC	N2	VDD33	E3
$\overline{AS}$	J16	RSV5	E17	NC	V15	NC	N3	VDD33	F3
CHICLK	R16	RSV6	D17	NC	U15	NC	P1	VDD33	F15
CKSPD0	E18	RSV7	B18	NC	T15	NC	P2	VDD33	H3
CKSPD1	D16	RSV8	C18	NC	V16	NC	R1	VDD33	J3
$\overline{CS}$	J18	RSV9	D18	NC	U16	NC	R2	VDD33	K16
DATA00	K18	RSV10	T18	TCK	G17	NC	T1	VDD33	P3
DATA01	K17	RSV11	V17	TDI	G16	NC	T2	VDD33	R3
DATA02	L18	RXD00	V2	TDO	G18	NC	U1	VDD33	T5
DATA03	L17	RXD01	U3	TMS	G15	VDD15	C5	VDD33	T6
DATA04	L16	RXD02	V3	TRSTN	H18	VDD15	C6	VDD33	T9
DATA05	M18	RXD03	U4	TXD00	B1	VDD15	C7	VDD33	T10
DATA06	M17	RXD04	V4	TXD01	C2	VDD15	C12	VDD33	T14
DATA07	M16	RXD05	U5	TXD02	C1	VDD15	C13	VDD33	T17
DATA08	M15	RXD06	V5	TXD03	D2	VDD15	C14	VDDPLL	R14
DATA09	N18	RXD07	U6	TXD04	D1	VDD15	D5	NC	K3
DATA10	N17	NC	V6	TXD05	E2	VDD15	D6	NC	T4
DATA11	N16	NC	T7	TXD06	E1	VDD15	D7	VSS	A1
DATA12	N15	NC	U7	TXD07	F2	VDD15	D12	VSS	A18

Table 2-1. Package Ball Assignments in Signal Name Order (continued)

Symbol	Ball	Symbol	Ball	Symbol	Ball	Symbol	Ball	Symbol	Ball
Vss	B2	Vss	C8	Vss	J9	Vss	R4	Vss	B3
Vss	C11	Vss	J10	Vss	R5	Vss	B4	Vss	C15
Vss	J11	Vss	R6	Vss	B5	Vss	C16	Vss	J15
Vss	R9	Vss	B6	Vss	D3	Vss	K4	Vss	R10
Vss	B7	Vss	D4	Vss	K8	Vss	R15	Vss	B8
Vss	D8	Vss	K9	Vss	T3	Vss	B9	Vss	D11
Vss	K10	Vss	T12	Vss	B10	Vss	D15	Vss	K11
Vss	T13	Vss	B11	Vss	E4	Vss	L3	Vss	T16
Vss	B12	Vss	F4	Vss	L8	Vss	U2	Vss	B13
Vss	F16	Vss	L9	Vss	U17	Vss	B14	Vss	H8
Vss	L10	Vss	U18	Vss	B15	Vss	H9	Vss	L11
Vss	V1	Vss	B16	Vss	H10	Vss	L15	Vss	V18
Vss	B17	Vss	H11	Vss	M3	VSSPLL	R13	Vss	C3
Vss	J4	Vss	N4	Vss	C4	Vss	J8	Vss	P4

## 2.3 Package Ball Matrix

### 2.3.1 Top View

Table 2-2. Package Ball Assignments (Top View)

	1	2	3	4	5	6	7	8	9	10	11	12	13	14	15	16	17	18
<b>A</b>	V <sub>SS</sub>	ADDR15	ADDR14	ADDR13	ADDR12	ADDR11	ADDR10	ADDR09	ADDR08	ADDR07	ADDR06	ADDR05	ADDR04	ADDR03	ADDR02	ADDR01	ADDR00	V <sub>SS</sub>
<b>B</b>	TXD00	V <sub>SS</sub>	V <sub>SS</sub>	V <sub>SS</sub>	V <sub>SS</sub>	V <sub>SS</sub>	V <sub>SS</sub>	V <sub>SS</sub>	V <sub>SS</sub>	V <sub>SS</sub>	V <sub>SS</sub>	V <sub>SS</sub>	V <sub>SS</sub>	V <sub>SS</sub>	V <sub>SS</sub>	V <sub>SS</sub>	V <sub>SS</sub>	RSV7
<b>C</b>	TXD02	TXD01	V <sub>SS</sub>	V <sub>SS</sub>	VDD15	VDD15	VDD15	V <sub>SS</sub>	VDD33	VDD33	V <sub>SS</sub>	VDD15	VDD15	VDD15	V <sub>SS</sub>	V <sub>SS</sub>	VDD33	RSV8
<b>D</b>	TXD04	TXD03	V <sub>SS</sub>	V <sub>SS</sub>	VDD15	VDD15	VDD15	V <sub>SS</sub>	VDD33	VDD33	V <sub>SS</sub>	VDD15	VDD15	VDD15	V <sub>SS</sub>	CKSPD1	RSV6	RSV9
<b>E</b>	TXD06	TXD05	VDD33	V <sub>SS</sub>	—	—	—	—	—	—	—	—	—	—	RSV3	RSV4	RSV5	CKSPD0
<b>F</b>	NC	TXD07	VDD33	V <sub>SS</sub>	—	—	—	—	—	—	—	—	—	—	VDD33	V <sub>SS</sub>	RSV1	RSV2
<b>G</b>	NC	NC	TXD09	VDD15	—	—	—	—	—	—	—	—	—	—	TMS	TDI	TCK	TDO
<b>H</b>	NC	NC	VDD33	VDD15	—	—	—	V <sub>SS</sub>	V <sub>SS</sub>	V <sub>SS</sub>	V <sub>SS</sub>	—	—	—	RESET	INT	DT	TRSTN
<b>J</b>	NC	NC	VDD33	V <sub>SS</sub>	—	—	—	V <sub>SS</sub>	V <sub>SS</sub>	V <sub>SS</sub>	V <sub>SS</sub>	—	—	—	V <sub>SS</sub>	AS	R/W	CS
<b>K</b>	NC	NC	NC	V <sub>SS</sub>	—	—	—	V <sub>SS</sub>	V <sub>SS</sub>	V <sub>SS</sub>	V <sub>SS</sub>	—	—	—	MPUCLK	VDD33	DATA01	DATA00
<b>L</b>	NC	NC	V <sub>SS</sub>	VDD15	—	—	—	V <sub>SS</sub>	V <sub>SS</sub>	V <sub>SS</sub>	V <sub>SS</sub>	—	—	—	V <sub>SS</sub>	DATA04	DATA03	DATA02
<b>M</b>	NC	NC	V <sub>SS</sub>	VDD15	—	—	—	—	—	—	—	—	—	—	DATA08	DATA07	DATA06	DATA05
<b>N</b>	NC	NC	NC	V <sub>SS</sub>	—	—	—	—	—	—	—	—	—	—	DATA12	DATA11	DATA10	DATA09
<b>P</b>	NC	NC	VDD33	V <sub>SS</sub>	—	—	—	—	—	—	—	—	—	—	PAR1	DATA15	DATA14	DATA13
<b>R</b>	NC	NC	VDD33	V <sub>SS</sub>	V <sub>SS</sub>	V <sub>SS</sub>	VDD15	VDD15	V <sub>SS</sub>	V <sub>SS</sub>	VDD15	VDD15	VSSPLL	VDDPLL	V <sub>SS</sub>	CHICLK	HIZ	PAR0
<b>T</b>	NC	NC	V <sub>SS</sub>	NC	VDD33	VDD33	NC	NC	VDD33	VDD33	FSYNC	V <sub>SS</sub>	V <sub>SS</sub>	VDD33	NC	V <sub>SS</sub>	VDD33	RSV10
<b>U</b>	NC	V <sub>SS</sub>	RXD01	RXD03	RXD05	RXD07	NC	NC	NC	NC	NC	NC	NC	NC	NC	NC	V <sub>SS</sub>	V <sub>SS</sub>
<b>V</b>	V <sub>SS</sub>	RXD00	RXD02	RXD04	RXD06	NC	NC	NC	NC	NC	NC	NC	NC	NC	NC	NC	RSV11	V <sub>SS</sub>

2.3.2 Bottom View

Table 2-3. Package Ball Assignments (Bottom View)

	1	2	3	4	5	6	7	8	9	10	11	12	13	14	15	16	17	18
V	VSS	RXD00	RXD02	RXD04	RXD06	NC	NC	NC	NC	NC	NC	NC	NC	NC	NC	NC	RSV11	VSS
U	NC	VSS	RXD01	RXD03	RXD05	RXD07	NC	NC	NC	NC	NC	NC	NC	NC	NC	NC	VSS	VSS
T	NC	NC	VSS	NC	VDD33	VDD33	NC	NC	VDD33	VDD33	FSYNC	VSS	VSS	VDD33	NC	VSS	VDD33	RSV10
R	NC	NC	VDD33	VSS	VSS	VSS	VDD15	VDD15	VSS	VSS	VDD15	VDD15	VSSPLL	VDDPLL	VSS	CHICLK	$\overline{\text{HI\bar{Z}}}$	PAR0
P	NC	NC	VDD33	VSS	—	—	—	—	—	—	—	—	—	—	PAR1	DATA15	DATA14	DATA13
N	NC	NC	NC	VSS	—	—	—	—	—	—	—	—	—	—	DATA12	DATA11	DATA10	DATA09
M	NC	NC	VSS	VDD15	—	—	—	—	—	—	—	—	—	—	DATA08	DATA07	DATA06	DATA05
L	NC	NC	VSS	VDD15	—	—	—	VSS	VSS	VSS	VSS	—	—	—	VSS	DATA04	DATA03	DATA02
K	NC	NC	NC	VSS	—	—	—	VSS	VSS	VSS	VSS	—	—	—	MPUCLK	VDD33	DATA01	DATA00
J	NC	NC	VDD33	VSS	—	—	—	VSS	VSS	VSS	VSS	—	—	—	VSS	$\overline{\text{A\bar{S}}}$	R/ $\overline{\text{W}}$	$\overline{\text{C\bar{S}}}$
H	NC	NC	VDD33	VDD15	—	—	—	VSS	VSS	VSS	VSS	—	—	—	$\overline{\text{RESE\bar{T}}}$	$\overline{\text{INT}}$	$\overline{\text{DT}}$	TRSTN
G	NC	NC	NC	VDD15	—	—	—	—	—	—	—	—	—	—	TMS	TDI	TCK	TDO
F	NC	TXD07	VDD33	VSS	—	—	—	—	—	—	—	—	—	—	VDD33	VSS	RSV1	RSV2
E	TXD06	TXD05	VDD33	VSS	—	—	—	—	—	—	—	—	—	—	RSV3	RSV4	RSV5	CKSPD0
D	TXD04	TXD03	VSS	VSS	VDD15	VDD15	VDD15	VSS	VDD33	VDD33	VSS	VDD15	VDD15	VDD15	VSS	CKSPD1	RSV6	RSV9
C	TXD02	TXD01	VSS	VSS	VDD15	VDD15	VDD15	VSS	VDD33	VDD33	VSS	VDD15	VDD15	VDD15	VSS	VSS	VDD33	RSV8
B	TXD00	VSS	VSS	VSS	VSS	VSS	VSS	VSS	VSS	VSS	VSS	VSS	VSS	VSS	VSS	VSS	VSS	RSV7
A	VSS	ADDR15	ADDR14	ADDR13	ADDR12	ADDR11	ADDR10	ADDR09	ADDR08	ADDR07	ADDR06	ADDR05	ADDR04	ADDR03	ADDR02	ADDR01	ADDR00	VSS

## 2.4 Ball Types

This table describes each type of input, output, and I/O ball used in the device.

**Table 2-4. Ball Types**

Type Label	Description
I	CMOS input, TTL switching thresholds.
I pd	CMOS input, TTL switching thresholds with internal pull-down resistor.
I pu	CMOS input, TTL switching thresholds with internal pull-up resistor.
O	CMOS output.
O od	Open-drain output.
I/O	Bidirectional ball. CMOS input with TTL switching thresholds and CMOS output.
P	Power and ground.

## 2.5 Ball Definitions

This section describes the function of each of the device balls. The balls are listed by ball name. The static parameters (drive currents, switching thresholds, etc.) for each ball type (input, output, etc.) are described in [Table 4-1](#) through [Table 4-3](#).

**Table 2-5. Timing Port**

Ball Name	Type	Name/Description
FSYNC	I	<b>Frame Synchronization.</b> This signal indicates the beginning of a 125 $\mu$ s frame event (8 kHz). The FSYNC ball can be programmed as active-low or active-high, but its polarity is the same for all concentration highway interfaces (CHI). FSYNC can be sampled on either the positive or negative edge of CHICLK. Time-slot numbers and bit offsets for each CHI are assigned relative to the detection of FSYNC.
CHICLK	I	<b>Clock.</b> This is the master synchronous clock for the transmit and receive concentration highways. The frequency can be 8.192 MHz or 16.384 MHz. It <b>must</b> be at least as fast as the highest CHI data rate.
CKSPD0	I	<b>Clock Speed.</b> Static control input that should be tied according to the frequency of CHICLK. If CHICLK is connected to an 8.192 MHz source, CKSPD0 should be tied to Vss. If CHICLK is connected to a 16.384 MHz source, CKSPD0 should be tied to VDD33.
CKSPD1	I pd	<b>Clock Speed.</b> Reserved, leave disconnected. 20 k $\Omega$ pull-down resistor.

**Table 2-6. Transmit and Receive Concentration Highways**

Ball Name	Type	Name/Description
RXD[7:0]	I pd	<b>Receive Data [7:0].</b> Receive concentration highways. These are serial, synchronous data streams, which may be individually programmed to operate at 2.048 Mbits/s, 4.096 Mbits/s, 8.192 Mbits/s, or 16.384 Mbits/s. They carry 32, 64, 128, or 256 time slots (respectively) each occupying eight contiguous bits. 20 k $\Omega$ pull-down resistor.
TXD[7:0]	O	<b>Transmit Data [7:0].</b> These are output concentration highway data streams with data rate options identical to the RXD inputs.

Table 2-7. Control Port

Ball Name	Type	Name/Description
MPUCLK	I	<b>Processor Clock.</b> This clock is used to sample address, data, and control signals from the microprocessor. This clock must be within the range of 0 MHz—66 MHz. Required for operation.
$\overline{CS}$	I	<b>Chip Select.</b> Active-low chip select. This input is held low for the duration of any read or write access to the device. Required for operation.
$\overline{AS}$	I	<b>Address Strobe.</b> Active-low address strobe that is one MPUCLK cycle wide at the start of a microprocessor access cycle to the device. This is used to initiate a microprocessor access. Required for operation.
$R/\overline{W}$	I	<b>Read/Write.</b> Cycle selection. $R/\overline{W}$ is set high during a read cycle, or set low for a write cycle. Required for operation.
ADDR[15:0]	I pu	<b>Address [15:0].</b> ADDR[15] is the most significant bit and ADDR[0] is the least significant bit for addressing all the internal registers during microprocessor access cycles. All addresses are 16-bit word addresses; therefore, in a typical application ADDR[0] of the device would be connected to address bit 1 of a byte addressable system address bus. Required for operation. 200 k $\Omega$ pull-up resistor.  <b>Note:</b> The device is little-endian; the least significant byte is stored in the lowest address and the most significant byte is stored in the highest address. Care must be exercised when connecting to microprocessors that use big-endian byte ordering.
DATA[15:0]	I/O	<b>Data [15:0].</b> Data bus for all transfers between the microprocessor and the internal registers. The balls are inputs during write cycles and outputs during read cycles. DATA[15] is the most significant bit, and DATA[0] is the least significant bit. Required for operation.
PAR[1:0]	I/O	<b>Control Port Parity [1:0].</b> Byte-wide parity bits for data. PAR[1] is the parity for DATA[15:8], and PAR[0] is the parity for DATA[7:0]. The parity sense (even or odd) is application programmable via a register bit in the device. <b>Not</b> required for operation.
$\overline{DT}$	O	<b>Data Transfer Acknowledge.</b> Active-low for one MPUCLK cycle. Indicates that <u>data</u> has been written during <u>write</u> cycles or that data is valid during read cycles. High impedance when $\overline{CS}$ is a 1 and driven when CS is 0. Required for operation.
$\overline{INT}$	O od	<b>Interrupt.</b> This output is asserted low to indicate that an interrupt condition has occurred. This signal remains active-low until the interrupt status register has been cleared or masked.

Table 2-8. Initialization and Test Access

Ball Name	Type	Name/Description
$\overline{RESET}$	I pu	<b>Reset.</b> Global reset, active-low. Initializes all internal registers to their default state. The reset occurs asynchronously, but $\overline{RESET}$ should be held low for at least two CHICLK periods. 20 k $\Omega$ pull-up resistor.
TCK	I pu	<b>Test Clock.</b> This signal provides timing for the boundary-scan and test access port (TAP) controller. Should be static, except during boundary-scan testing. 20 k $\Omega$ pull-up resistor.
TDI	I pu	<b>Test Data In.</b> Data input for the boundary-scan. Sampled on the rising edge of TCK. 20 k $\Omega$ pull-up resistor.
TMS	I pu	<b>Test Mode Select (Active-Low).</b> Controls boundary-scan test operations. TMS is sampled on the rising edge of TCK. 20 k $\Omega$ pull-up resistor.
TRSTN	I pd	<b>Test Reset (Active-Low).</b> This signal is an asynchronous reset for the TAP controller. 20 k $\Omega$ pull-down resistor.
TDO	O	<b>Test Data Out.</b> Updated on the falling edge of TCK. The TDO output is high impedance except when scanning out test data.
$\overline{HIZ}$	I pu	<b>Output Enable.</b> All output and bidirectional buffers will be high-impedance when this input is low unless boundary scan is enabled (TRSTN = 1). 20 k $\Omega$ pull-up resistor.
RSV[11:1]	—	<b>Reserved [11:1].</b> These balls are used by Agere Systems during the manufacturing process; they must be left unconnected.

Table 2-9. Power Balls

Symbol	Type	Name/Description
VDD33	P	<b>I/O Power.</b> Power supply balls for the I/O pads (3.3 V $\pm$ 5%).
VDD15	P	<b>Core Power.</b> Power supply balls for the core (1.5 V $\pm$ 5%).
VSS	P	<b>Ground.</b> Common ground balls for 3.3 V and 1.5 V supplies.
VDDPLL	P	<b>PLL Power.</b> 1.5 V power supply for the internal phase-locked loop. Must include local 0.01 $\mu$ F capacitor to VSSPLL.
VSSPLL	P	<b>PLL Ground.</b> Isolated ground for the internal phase-locked loop.

### 3 Operating Conditions and Reliability

#### 3.1 Absolute Maximum Ratings

Stresses in excess of the absolute maximum ratings can cause permanent damage to the device. These are absolute stress ratings only. Functional operation of the device is not implied at these or any other conditions in excess of those given in the operational sections of the data sheet. Exposure to absolute maximum ratings for extended periods can adversely affect device reliability.

**Table 3-1. Absolute Maximum Ratings**

Parameter	Min	Max	Unit
Supply Voltage (VDD33)	-0.5	4.2	V
Supply Voltage (VDD15)	-0.5	1.8	V
Input Voltage: TXD[7:0]	-0.5	5.5	V
All Other Inputs	-0.3	VDD33 + 0.3	V
Storage Temperature	-40	125	°C
Junction Temperature	—	125	°C

#### 3.2 Recommended Operating Conditions

Table 3-2 lists the voltages, along with the tolerances, that are required for proper operation of the device.

**Table 3-2. Operating Conditions**

Parameter	Min	Typ	Max	Unit
Supply Voltage (VDD33)	3.14	3.3	3.47	V
Supply Voltage (VDD15)	1.4	1.5	1.6	V
Ambient Temperature	-40	—	85	°C

#### 3.3 Handling Precautions

Although electrostatic discharge (ESD) protection circuitry has been designed into this device, proper precautions must be taken to avoid exposure to ESD and electrical overstress (EOS) during all handling, assembly, and test operations. Agere employs both a human-body model (HBM) and a charged-device model (CDM) qualification requirement in order to determine ESD-susceptibility limits and protection design evaluation. ESD voltage thresholds are dependent on the circuit parameters used in each of the models, as defined by JEDEC's JESD22-A114 (HBM) and JESD22-C101 (CDM) standards.

**Table 3-3. ESD Tolerance**

Device	Voltage	Type
TTSI002081	2,000 V	HBM (human-body model)
	500 V	CDM (charged-device model)

### 3.4 Thermal Parameters (Definitions and Values)

System and circuit board level performance depends not only on device electrical characteristics, but also on device thermal characteristics. The thermal characteristics frequently determine the limits of circuit board or system performance, and they can be a major cost adder or cost avoidance factor. When the die temperature is kept below 125 °C, temperature-activated failure mechanisms are minimized. The thermal parameters that Agere provides for its packages help the chip and system designer choose the best package for their applications, including allowing the system designer to thermally design and integrate their systems.

It should be noted that all the parameters listed below are affected, to varying degrees, by package design (including paddle size) and choice of materials, the amount of copper in the test board or system board, and system airflow.

#### Θ<sub>JA</sub> - Junction to Air Thermal Resistance

Θ<sub>JA</sub> is a number used to express the thermal performance of a part under JEDEC standard natural convection conditions.

Θ<sub>JA</sub> is calculated using the following formula:

$$\Theta_{JA} = (T_J - T_{amb}) / P; \text{ where } P = \text{power}$$

#### Θ<sub>JMA</sub> - Junction to Moving Air Thermal Resistance

Θ<sub>JMA</sub> is effectively identical to Θ<sub>JA</sub> but represents performance of a part mounted on a JEDEC four layer board inside a wind tunnel with forced air convection. Θ<sub>JMA</sub> is reported at airflows of 200 LFPM and 500 LFPM (linear feet per minute), which roughly correspond to 1 m/s and 2.5 m/s (respectively). Θ<sub>JMA</sub> is calculated using the following formula:

$$\Theta_{JMA} = (T_J - T_{amb}) / P$$

#### Θ<sub>JC</sub> - Junction to Case Thermal Resistance

Θ<sub>JC</sub> is the thermal resistance from junction to the top of the case. This number is determined by forcing nearly 100% of the heat generated in the die out the top of the package by lowering the top case temperature. This is done by placing the top of the package in contact with a copper slug kept at room temperature using a liquid refrigeration unit. Θ<sub>JC</sub> is calculated using the following formula:

$$\Theta_{JC} = (T_J - T_C) / P$$

#### Θ<sub>JB</sub> - Junction to Board Thermal Resistance

Θ<sub>JB</sub> is the thermal resistance from junction to board. This number is determined by forcing the heat generated in the die out of the package through the leads or balls by lowering the board temperature and insulating the package top. This is done using a special fixture, which keeps the board in contact with a water chilled copper slug around the perimeter of the package while insulating the package top. Θ<sub>JB</sub> is calculated using the following formula:

$$\Theta_{JB} = (T_J - T_B) / P$$

#### Ψ<sub>JT</sub> - Junction Temperature to Case Temperature

Ψ<sub>JT</sub> correlates the junction temperature to the case temperature. It is generally used by the customer to infer the junction temperature while the part is operating in their system. It is not considered a true thermal resistance. Ψ<sub>JT</sub> is calculated using the following formula:

$$\Psi_{JT} = (T_J - T_C) / P$$

**Table 3-4. Thermal Parameter Values**

Parameter	Temperature °C/Watt
Θ <sub>JA</sub>	25.1
Θ <sub>JMA</sub> (1 m/s)	21.4
Θ <sub>JMA</sub> (2.5 m/s)	18.8
Θ <sub>JC</sub>	5.8
Θ <sub>JB</sub>	13.0

### 3.5 Power Consumption

Table 3-5. Power Consumption

Supply Voltage	Typ*	Max
VDD33	100 mW at 3.3 V	150 mW at 3.47 V
VDD15	275 mW at 1.5 V	325 mW at 1.6 V

\* MPUCLK = 66 MHz, CHICK = 16.384 MHz, TA = 25 °C, all CHIs active, all outputs loaded with 50 pF.

## 4 dc Electrical Characteristics

This section describes all the static parameters associated with all the ball types used in the device.

**Table 4-1. CMOS Inputs**

Parameter	Symbol	Conditions	Min	Typ	Max	Unit
Input Leakage Current	IIL	$V_{SS} < V_{IN} < V_{DD33}$	—	—	1*	$\mu\text{A}$
High-input Voltage	V <sub>IH</sub>	—	2.0	—	$V_{DD33} + 0.3$	V
Low-input Voltage	V <sub>IL</sub>	—	-0.3	—	0.8	V
Input Capacitance	C <sub>I</sub>	—	—	2.5	—	pF

\* Excludes current due to pull-up or pull-down resistors.

**Table 4-2. CMOS Outputs**

Parameter	Symbol	Conditions	Min	Typ	Max	Unit
Output Voltage Low	V <sub>OL</sub>	$I_{OL} = -10 \text{ mA}$	—	—	0.4	V
Output Voltage High	V <sub>OH</sub>	$I_{OL} = 10 \text{ mA}$	2.4	—	—	V
Output Current Low	I <sub>OL</sub>	—	—	—	10	mA
Output Current High	I <sub>OH</sub>	—	—	—	10	mA
Output Capacitance	C <sub>O</sub>	—	—	3	—	pF
HIZ Output Leakage Current	I <sub>OZ</sub>	—	—	—	10	$\mu\text{A}$

**Table 4-3. CMOS Bidirectionals (DATA[15:0])**

Parameter	Symbol	Conditions	Min	Typ	Max	Unit
Leakage Current	I <sub>L</sub>	$V_{SS} < V_{IN} < V_{DD33}$	—	—	11	$\mu\text{A}$
High-input Voltage	V <sub>IH</sub>	—	2.0	—	$V_{DD33} + 0.3$	V
Low-input Voltage	V <sub>IL</sub>	—	-0.3	—	0.8	V
Biput Capacitance	C <sub>IB</sub>	—	—	5.0	—	pF
Output Voltage Low	V <sub>OL</sub>	$I_{OL} = -10 \text{ mA}$	—	—	0.4	V
Output Voltage High	V <sub>OH</sub>	$I_{OL} = 10 \text{ mA}$	2.4	—	—	V

## 5 Timing Diagrams and ac Characteristics

Figure 5-1 and Figure 5-2 describe the timing specifications for the input clocks

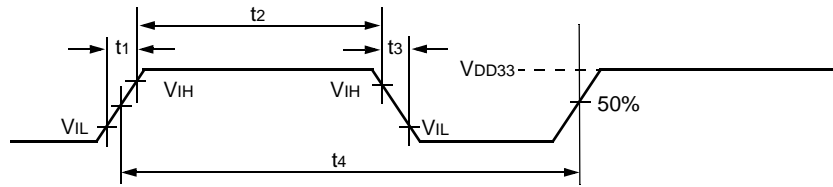

Figure 5-1. CHICLK Timing Specifications

Table 5-1. CHICLK Timing Specifications

Parameter	Description	Min	Typ	Max	Unit
t1	CHICLK Rise Time	—	2	7	ns
t2	CHICLK Width (8.192 MHz)*	48.84	—	73.24	ns
t2	CHICLK Width (16.384 MHz)*	24.42	—	36.62	ns
t3	CHICLK Fall Time	—	2	7	ns
t4	CHICLK Period (8.192 MHz)	—	122.07	—	ns
t4	CHICLK Period (16.384 MHz)	—	61.03	—	ns

\*  $V_{IH}$  to  $V_{IH}$  or  $V_{IL}$  to  $V_{IL}$ .

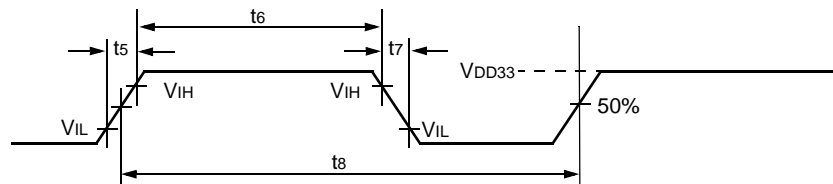

Figure 5-2. MPUCLK Timing Specifications

Table 5-2. MPUCLK Timing Specifications

Parameter	Description	Min	Typ	Max	Unit
t5	MPUCLK Rise Time	—	2	7	ns
t6	MPUCLK Width*	6.06	—	—	ns
t7	MPUCLK Fall Time	—	2	7	ns
t8	MPUCLK Period	15.2	—	—	ns

\*  $V_{IH}$  to  $V_{IH}$  or  $V_{IL}$  to  $V_{IL}$ .

Figure 5-3 shows the ac timing specifications for the device. All timing parameters are referenced to  $V_{IHmin}$  and  $V_{ILmax}$ . The reference signal polarity may be inverted for some timing parameters.

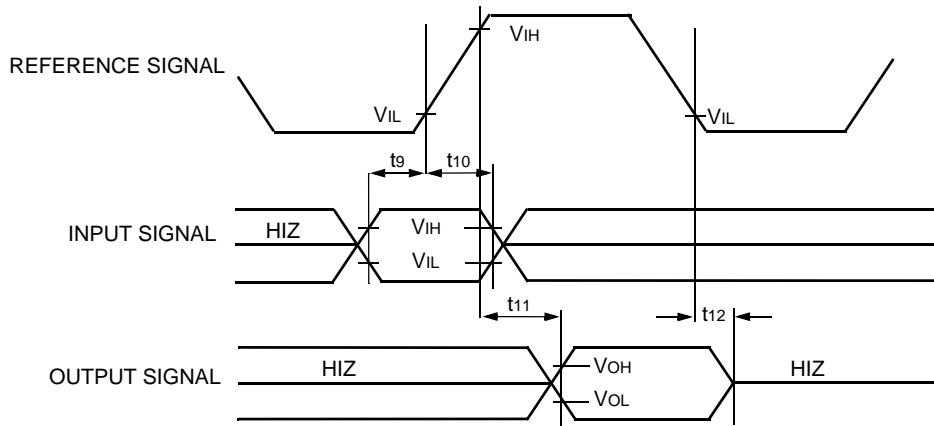

**Figure 5-3. ac Timing Measurement Specification**

**Table 5-3. ac Timing Measurement Specification**

Parameter	Description
t <sub>9</sub>	Setup Time
t <sub>10</sub>	Hold Time
t <sub>11</sub>	Output Delay
t <sub>12</sub>	Output 3-State Time

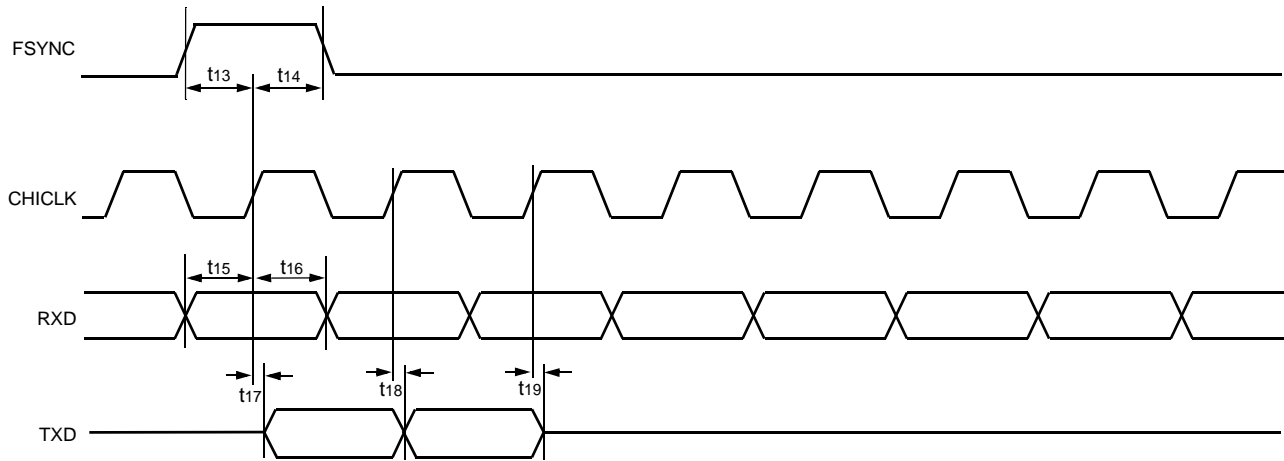

Note: This figure assumes the device is programmed to sample FSYNC on rising edge of CHICLK.

Figure 5-4. CHI Interface Timing

Table 5-4. CHI Interface Timing

Parameter	Description	Min	Max	Unit
t13	FSYNC Setup Time to Active CHICLK Edge	10	—	ns
t14	FSYNC Hold Time from Active CHICLK Edge	5	—	ns
t15	RXD Setup to Active CHICLK Edge	10	—	ns
t16	RXD Hold Time from Active CHICLK Edge	5	—	ns
t17	TXD High Z to Data Valid	—	15	ns
t18	TXD Propagation Delay from Active CHICLK Edge	2	12	ns
t19	Transmit Data High Impedance*	—	15	ns

\* Applies if Driver\_Enable\_Control = 01; see Figure 5-15, CHI 3-State Output Control, if Driver\_Enable\_Control = 11.

All timing specifications are with respect to  $V_{IHmin}$  and  $V_{ILmax}$  as shown in Figure 5-3. All timing specifications also apply under the following conditions:

- If FS is active-low.
- If the falling edge of CHICLK is specified as the active edge.
- At all RXD and TXD rates (16.384 Mbits/s, 8.192 Mbits/s, 4.096 Mbits/s, or 2.048 Mbits/s) with a CHICLK frequency of 16.384 MHz or 8.192 MHz.

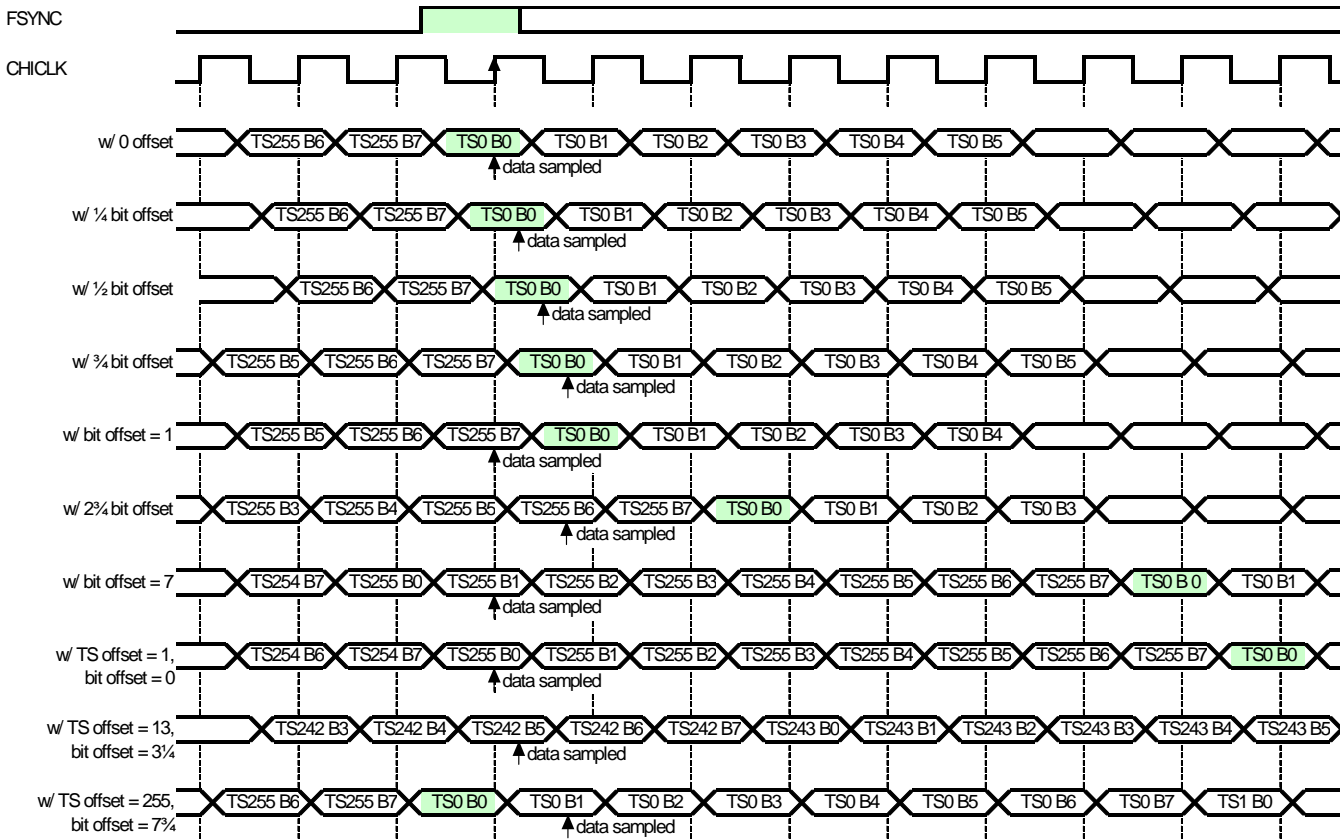

Note: For this timing diagram, it is assumed that FSYNC has been programmed to be active-high, and to be sampled by the rising edge of the CHICLK.

Figure 5-5. Typical Receive CHI Timing with 16.384 Mb/s Data and 16.384 MHz CHICLK

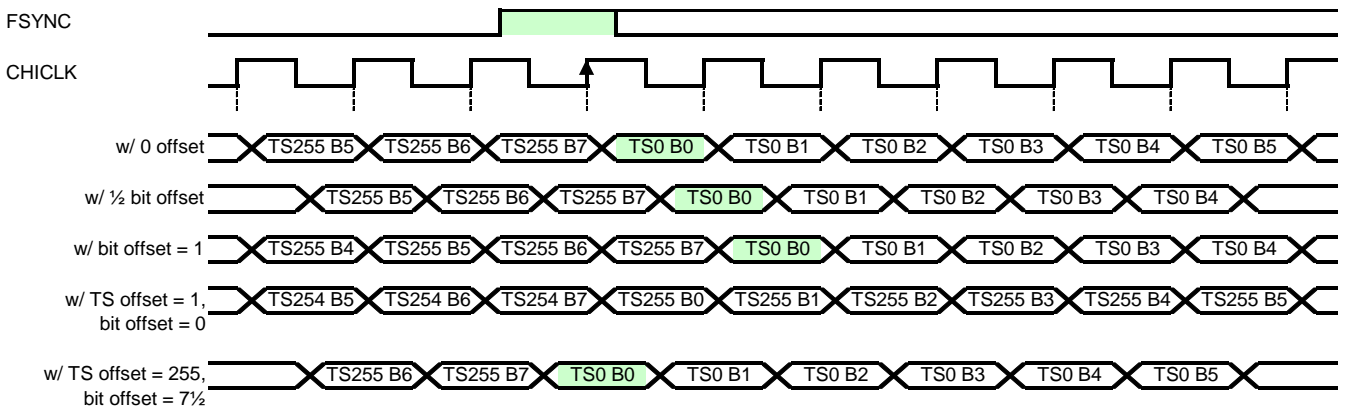

Notes:  
1/4 bit offset not valid with 16 Mb/s data.

For this timing diagram, it is assumed that FSYNC has been programmed to be active-high, and to be sampled by the rising edge of the CHICLK.

Figure 5-6. Transmit CHI Timing with 16.384 Mb/s Data and 16.384 MHz CHICLK

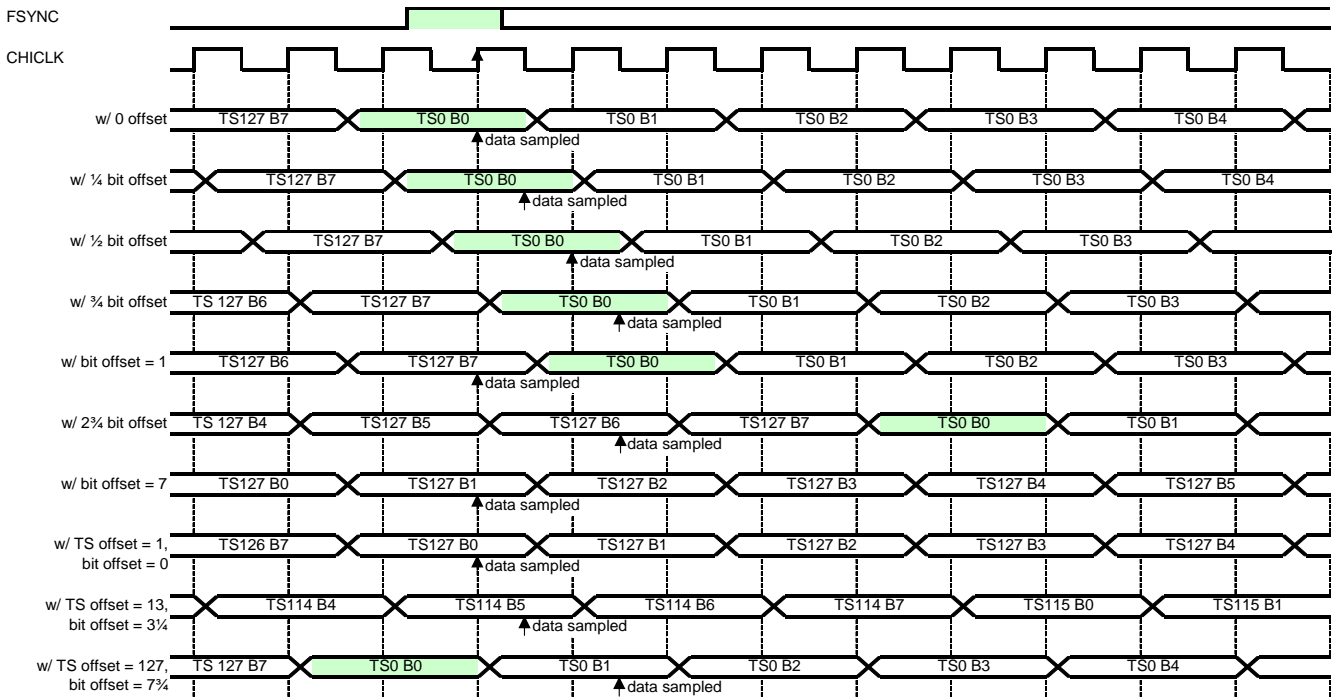

Note: For this timing diagram, it is assumed that FSYNC has been programmed to be active-high, and to be sampled by the rising edge of the CHICK.

Figure 5-7. Typical Receive CHI Timing with 8.192 Mbits/s Data and 16.384 MHz CHICK

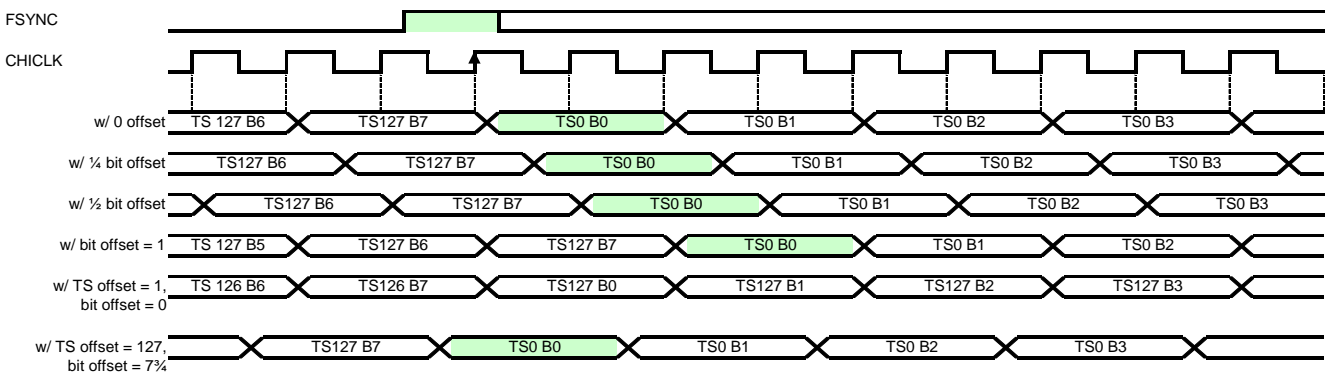

Note: For this timing diagram, it is assumed that FSYNC has been programmed to be active-high, and to be sampled by the rising edge of the CHICK.

Figure 5-8. Transmit CHI Timing with 8.192 Mbits/s Data and 16.384 MHz CHICK

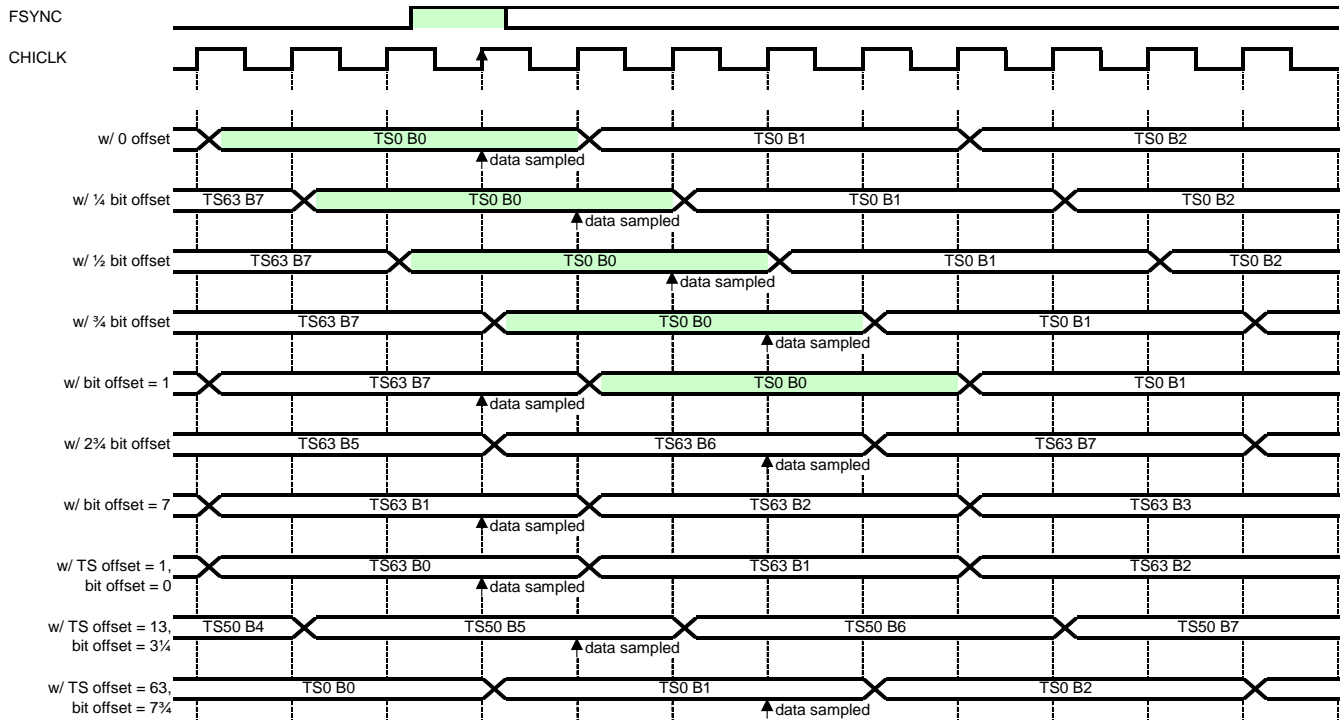

Note: For this timing diagram, it is assumed that FSYNC has been programmed to be active-high, and to be sampled by the rising edge of the CHICLK.

**Figure 5-9. Typical Receive CHI Timing with 4.096 Mbits/s Data and 16.384 MHz CHICLK**

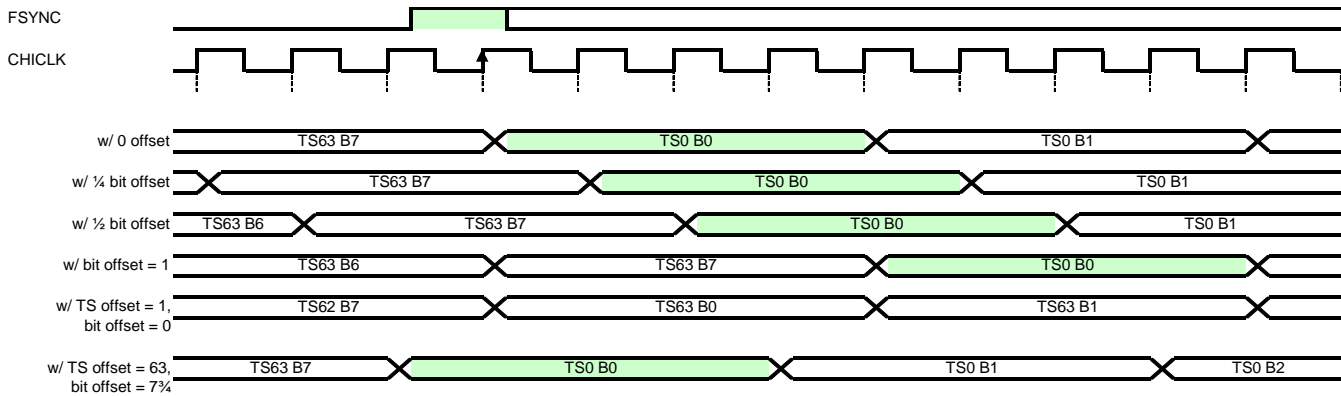

Note: For this timing diagram, it is assumed that FSYNC has been programmed to be active-high, and to be sampled by the rising edge of the CHICLK.

**Figure 5-10. Transmit CHI Timing with 4.096 Mbits/s Data and 16.384 MHz CHICLK**

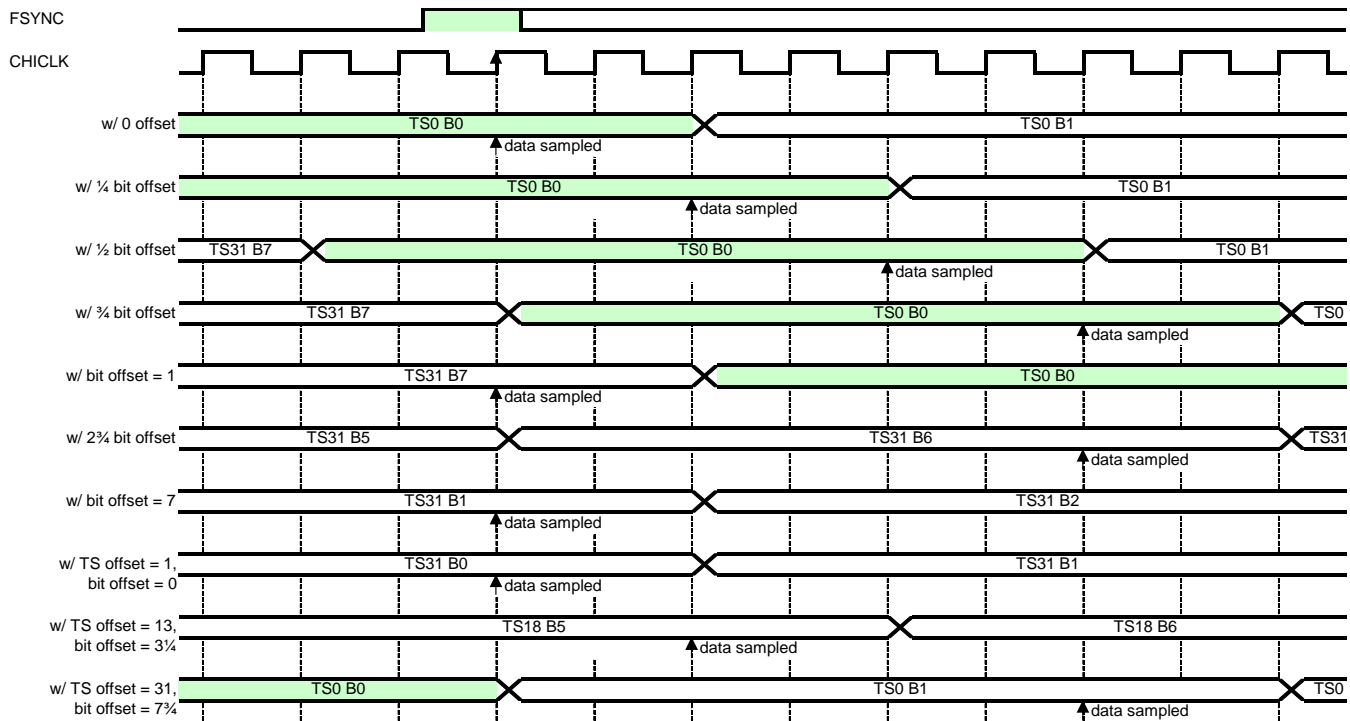

Note: For this timing diagram, it is assumed that FSYNC has been programmed to be active-high, and to be sampled by the rising edge of the CHICLK.

**Figure 5-11. Typical Receive CHI Timing with 2.048 Mbits/s Data and 16.384 MHz CHICLK**

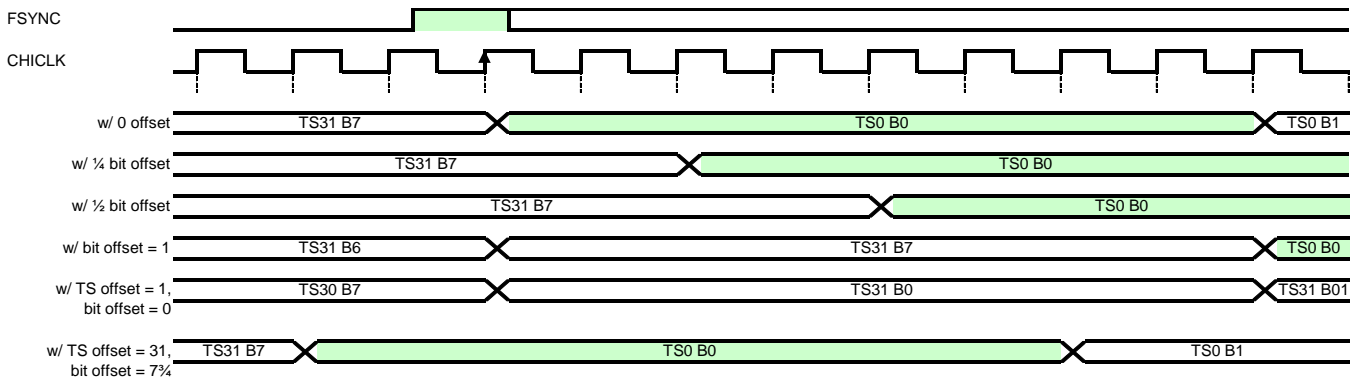

Note: For this timing diagram, it is assumed that FSYNC has been programmed to be active-high, and to be sampled by the rising edge of the CHICLK.

**Figure 5-12. Transmit CHI Timing with 2.048 Mbits/s Data and 16.384 MHz CHICLK**

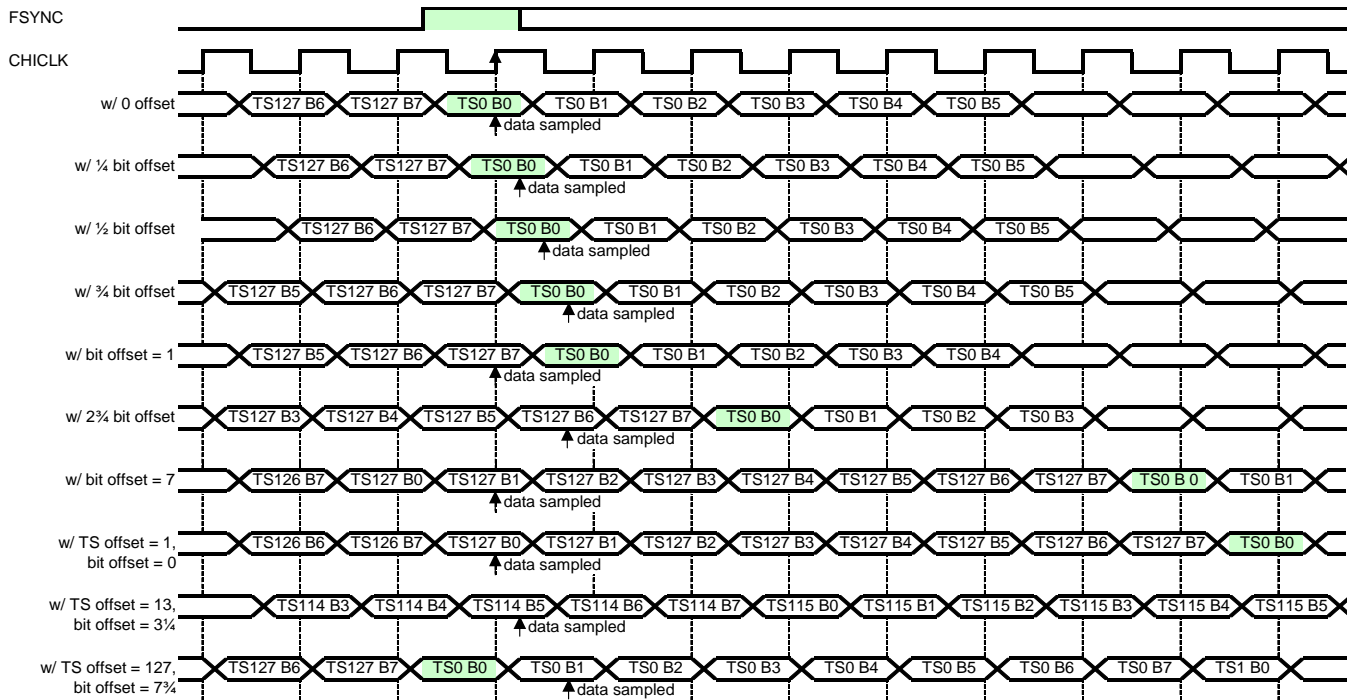

Note: For this timing diagram, it is assumed that FSYNC has been programmed to be active-high, and to be sampled by the rising edge of the CHICLK.

**Figure 5-13. Typical Receive CHI Timing with 8.192 Mb/s Data and 8.192 MHz CHICLK**

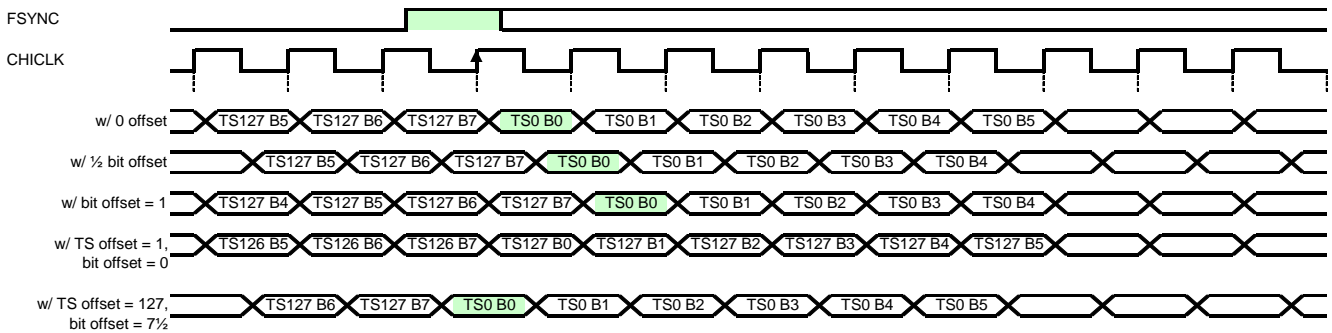

Notes:  
 1/4 bit offset not valid with 8 MHz data and 8 MHz clock.

For this timing diagram, it is assumed that FSYNC has been programmed to be active-high, and to be sampled by the rising edge of the CHICLK.

**Figure 5-14. Transmit CHI Timing with 8.192 Mb/s Data and 8.192 MHz CHICLK**

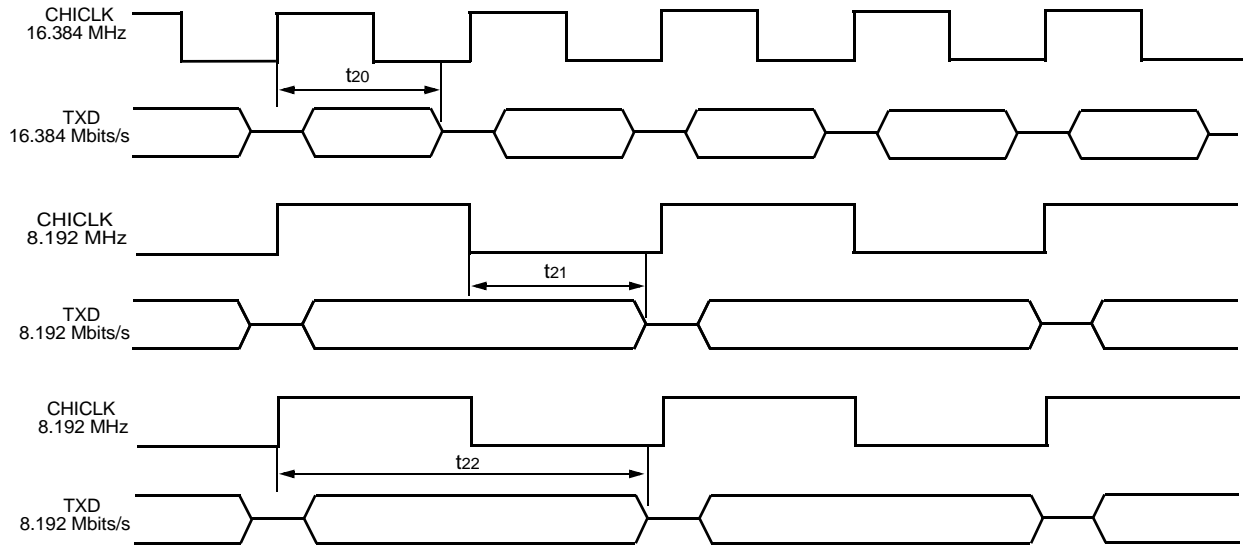

Figure 5-15. CHI 3-State Output Control

Table 5-5. CHI 3-State Output Control

Control in the table below refers to bits [6:4] in Table 6-51 Transmit\_CHI\_Global\_Configuration (Read/Write) on page 52. This only applies if bits 13 and 12 of the corresponding register in Table 6-48 Transmit\_CHI\_Configuration (Read/Write) on page 50 are set to 11.

Parameter	Control	Reference Point*	Min <sup>†</sup>	Max*	Unit
t20	000	After Previous Like Edge in 16 MHz	50	59	ns
	001	After Previous Like Edge in 16 MHz	44	53	ns
	010	After Previous Like Edge in 16 MHz	38	47	ns
	011	After Previous Like Edge in 16 MHz	32	41	ns
t21	000	After Previous Opposite Edge in 8 MHz	50	59	ns
	001	After Previous Opposite Edge in 8 MHz	44	53	ns
	010	After Previous Opposite Edge in 8 MHz	38	47	ns
	011	After Previous Opposite Edge in 8 MHz	32	41	ns
t22	100	After Previous Like Edge (8 MHz mode only)	111	120	ns
	101	After Previous Like Edge (8 MHz mode only)	105	114	ns
	110	After Previous Like Edge (8 MHz mode only)	99	108	ns
	111	After Previous Like Edge (8 MHz mode only)	93	102	ns

\* Like edge is the reference edge (rising or falling) as defined by the Transmit\_Clock\_Edge bit in Table 6-48 Transmit\_CHI\_Configuration (Read/Write) on page 50.

† All timing specifications are with respect to the parameters shown in Figure 5-3.

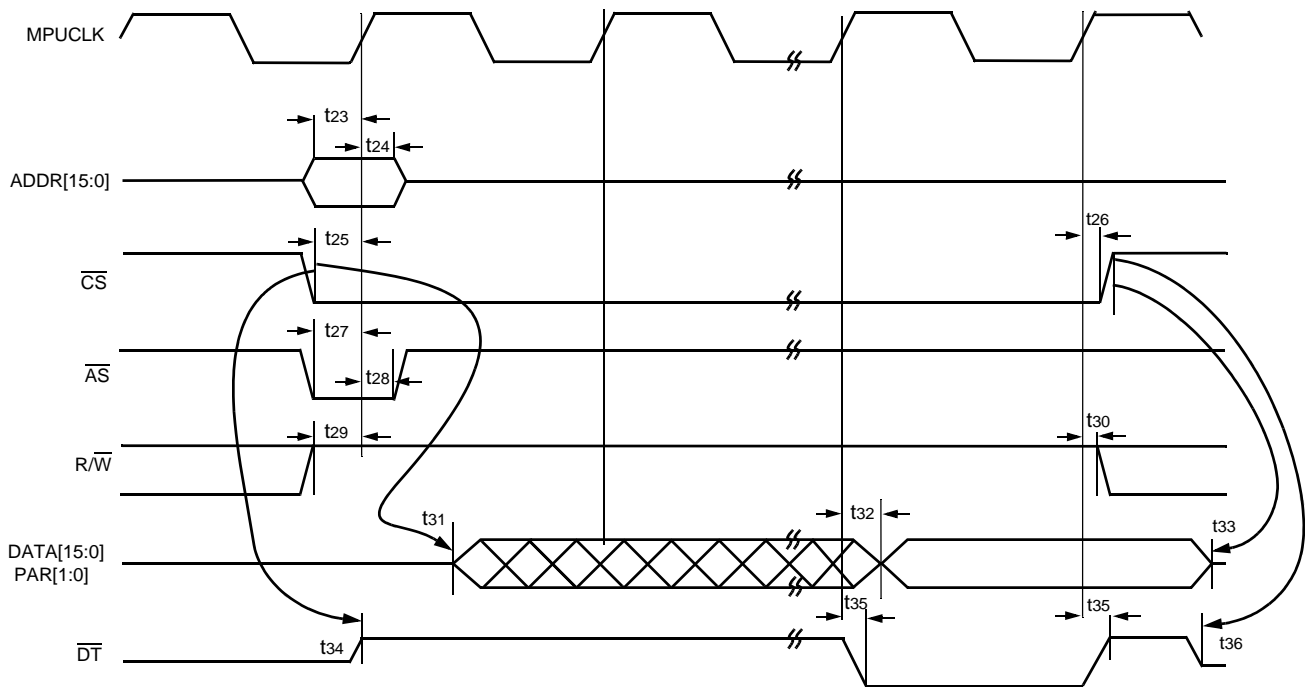

Figure 5-16. Microprocessor Port Timing—Read Cycle

Table 5-6. Microprocessor Port Timing—Read Cycle

Parameter	Description	Min*	Max*	Unit
t23	Address Setup	5	—	ns
t24	Address Hold	1	—	ns
t25	Chip Select Setup	5	—	ns
t26	Chip Select Hold	1	—	ns
t27	Address Strobe Setup	5	—	ns
t28	Address Strobe Hold	1	—	ns
t29	R/W Setup	5	—	ns
t30	R/W Hold	1	—	ns
t31	Data Output Enable	—	15	ns
t32	Data Clock to Valid	1	7	ns
t33	Data High Impedance	—	8	ns
t34	DT High Impedance to Valid	1	15	ns
t35	DT Clock to Out	1	7	ns
t36	DT Valid to High Impedance	1	8	ns

\* All timing specifications are with respect to the parameters shown in Figure 5-3.

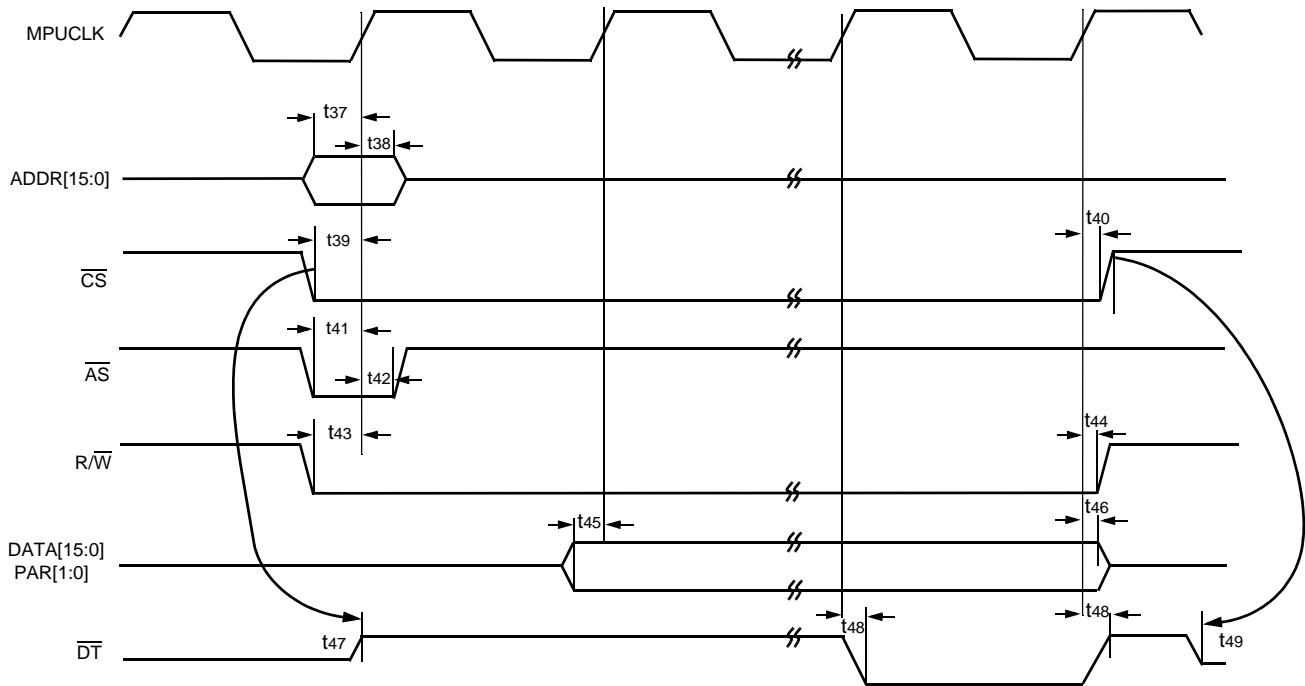

Figure 5-17. Microprocessor Port Timing—Write Cycle

Table 5-7. Microprocessor Port Timing—Write Cycle

Parameter	Description	Min*	Max*	Unit
t37	Address Setup	5	—	ns
t38	Address Hold	1	—	ns
t39	Chip Select Setup	5	—	ns
t40	Chip Select Hold	1	—	ns
t41	Address Strobe Setup	5	—	ns
t42	Address Strobe Hold	1	—	ns
t43	R/W Setup	5	—	ns
t44	R/W Hold	1	—	ns
t45	Data Setup	5	—	ns
t46	Data Hold	1	—	ns
t47	DT High Impedance to Valid	1	15	ns
t48	DT Clock to Out	1	7	ns
t49	DT Valid to High Impedance	1	8	ns

\* All timing specifications are with respect to the parameters shown in Figure 5-3.

**Note:** Posted writes follow the same timing shown in Figure 5-17 and Table 5-7. A posted write may return a  $\overline{DT}$  prior to the device completing the write cycle. This allows the microprocessor to continue operation while the device completes the write.

## **Register Description**

## 6 Register Description

This section describes the purpose and operation of each register bit, its dependencies, and its initial state.

### 6.1 Device Addressing Notes

All device addresses shown are physical byte offset addresses in the microprocessor space, not the actual addresses in the device itself. The device uses  $2^{17}$  bytes of address spectrum.

The following assumptions are made:

- The device is connected to the microprocessor as a 16-bit word accessed device (not byte addressable), with ADDR[00] connected to address bit 1 of the microprocessor.
- The microprocessor's address bit 0 (high/low byte) is not used by the device.

**Note:** All addresses are expressed in hexadecimal. Unless otherwise indicated by a 0x, register bit states (in default states) are expressed in binary.

### 6.2 Acronyms Used

- **CS**—Connection store.
- **CSG**—Connection store generator.
- **PLL**—Phase-locked loop.
- **SF**—Switch fabric.
- **TPG**—Test pattern generator.
- **TPM**—Test pattern monitor.
- **VCO**—Voltage-controlled oscillator.

### 6.3 Address Map

Table 6-1. Address Map

Register Groups	Address Space (Words)	Address Range
Global Control	512	0x00000—0x003FE
Connection Store Generator	256	0x00400—0x005FE
Test Pattern Generator and Monitor	256	0x00600—0x007FE
Reserved	256	0x00800—0x009FE
CHI Control	896	0x00A00—0x010FE
Switch Fabric Control	1,920	0x01100—0x01FFE
Reserved	4,096	0x02000—0x03FFE
Reserved	24,576	0x04000—0x0FFFE
Connection Store	4,096	0x10000—0x11FFE
Reserved	28,672	0x12000—0x1FFFE

**Note:** The address space is expressed in decimal. Because ADDR[00] on the device is connected to ADDR[01] on the microprocessor, the device only occupies even addresses in the microprocessor address space.

## 6.4 Register Summary

**Table 6-2. Global Registers**

Address	Register	Access Mode
0x00000	Version_Control	Read Only
0x00002	Chip_Identity	Read Only
0x00004	Summary_Interrupt_Status	Read Only
0x00006	Summary_Interrupt_Mask	Read/Write
0x00008	CPU_Access_Error	CORWN*
0x0000A	CPU_Access_Error_Mask	Read/Write
0x0000C	Global_Control	Read/Write
0x0000E	PLL_Control	Read/Write
0x00010	Power_Control	Read/Write
0x00012	Invalid_Address_Trap	Read Only
0x00014	Scratch_Register	Read/Write

\* Clear-on-read/clear-on-write.

**Table 6-3. Connection Store Generator Registers**

Address	Register	Access Mode
0x00400	CSG_Control	Read/Write
0x00402	CSG_Status	Read Only
0x00404	CSG_Starting_Address	Read/Write
0x00406	CSG_Ending_Address	Read/Write
0x00408	CSG_Write_Enable_Low	Read/Write
0x0040A	CSG_Write_Enable_High	Read/Write
0x00410	CSG_Seed_Low	Read/Write
0x00412	CSG_Seed_High	Read/Write
0x00418	CSG_OR_Mask_Low	Read/Write
0x0041A	CSG_OR_Mask_High	Read/Write
0x0041C	CSG_AND_Mask_Low	Read/Write
0x0041E	CSG_AND_Mask_High	Read/Write
0x00428	CS_Stream_Control	Read/Write
0x0042A	CSG_Configuration	Read/Write

**Table 6-4. Test Pattern Generator and Monitor Registers**

Address	Register	Access Mode
0x00600	TPG_Configuration	Read/Write
0x00602	TPG_User_Pattern	Read/Write
0x00604	TPM_Configuration	Read/Write
0x00606	TPM_User_Pattern	Read/Write
0x00608	TPM_Error_Count	Sat/Roll*
0x0060A	TPG_Inject_Error_Count	Write Only
0x0060C	TPG_Data_Invert_Mask	Read/Write
0x0060E	TPM_Status	Read Only
0x00610	TPM_Status_Mask	Read/Write

\* Saturate/rollover.

**Table 6-5. Concentration Highway Configuration Registers**

Address	Register	Access Mode
0x00A00—0x00A0E	Receive_CHI_Configuration	Read/Write
0x00A80	Receive_CHI_Status	CORWN*
0x00A82	Receive_CHI_Status_Mask	Read/Write
0x00A84	Receive_CHI_Global_Configuration	Read/Write
0x00C00—0x00C0E	Transmit_CHI_Configuration	Read/Write
0x00C80	Transmit_CHI_Status	CORWN*
0x00C82	Transmit_CHI_Status_Mask	Read/Write
0x00C84	Transmit_CHI_Global_Configuration	Read/Write
0x01000—0x0100E	Receive_CHI_Time_Slot_Offset	Read/Write
0x01080—0x0108E	Transmit_CHI_Time_Slot_Offset	Read/Write

\* Clear-on-read/clear-on-write.

**Table 6-6. Switch Fabric Control**

Address	Register	Access Mode
0x01124	SF_Status	CORWN*
0x01126	SF_Status_Mask	Read/Write
0x01142	Data_Store_Time_Slot_Capture_Select	Read/Write
0x01144	Data_Store_Captured_Data	Read Only
0x01146	Connection_Store_Parity_Error_Address_Trap	CORWN*
0x01148	Receive_Link_Offset	Read Only
0x0114C	Transmit_Link_Offset	Read/Write
0x0114E	Wide_Mode_Control	Read/Write

\* Clear-on-read/clear-on-write.

Table 6-7. Connection Store

Address	Register	Access Mode
0x10000—0x11FFC	Low_Control_Word	Read/Write
0x10002—0x11FFE	High_Control_Word	Read/Write

Table 6-8. Reserved Registers

The following register will not cause an Invalid\_Address\_Error (see Table 6-13) and are reserved.

Address	Register	Access Mode
0x00016	Reserved_0	Read/Write

## 6.5 Global Control Registers

The default field indicates the state of each register bit following a hardware or software reset cycle.

These registers are located at the top level of the design and are used to determine operations that affect more than one block within the device. These could be registers required for control of the microprocessor port block or register functions that are not naturally associated with other blocks. Global resets and output enables are included in this section.

Table 6-9. Version\_Control (Read Only)

Address	Bit	Name/Description	Default
0x00000	15	Reserved.	0
	14:12	Version_Number. TSI version number. TSI version register will change each time the device is changed.	001
	11:0	Agere_Systems_Identification_Number. This is the ID code assigned to Agere Systems Inc. by the JTAG standards body.	0x190

Table 6-10. Chip\_Identity (Read Only)

Address	Bit	Name/Description	Default
0x00002	15:0	Chip_Identity. This register contains the unique identification code for the device.	0x26D1

Table 6-11. Summary\_Interrupt\_Status (Read Only)

Address	Bit	Name/Description	Default
0x00004	15:6	<b>Unused.</b>	—
	5	<b>Transmit_CHI_Interrupt.</b> Active-high flag indicating an unmasked error or status is present in the Transmit_CHI_Status register (see Table 6-49). 0 = No transmit CHI error(s) detected. 1 = Transmit CHI Error(s) detected.	—
	4	<b>Receive_CHI_Interrupt.</b> Active-high flag indicating that an unmasked error or status is present in the Receive_CHI_Status register (see Table 6-45). 0 = No receive CHI error(s) detected. 1 = Receive CHI error(s) detected.	—
	3	<b>Unused.</b>	—
	2	<b>TPM_Interrupt.</b> Active-high flag indicating an unmasked error or status is present in the TPM_Status register (see Table 6-42). 0 = No test pattern monitor error(s) detected. 1 = Test pattern error(s) detected.	—
	1	<b>SF_Interrupt.</b> Active-high flag indicating an unmasked error is present in the SF_Status register (see Table 7-1). 0 = No switch fabric error(s) detected. 1 = Switch fabric error(s) detected.	—
	0	<b>CPU_Access_Interrupt.</b> Active-high flag indicating an unmasked error has been detected by the CPU_Access_Error register (see Table 6-13). 0 = No microprocessor access error(s) detected. 1 = Microprocessor access error(s) detected.	—

Table 6-12. Summary\_Interrupt\_Mask (Read/Write)

Address	Bit	Name/Description	Default
0x00006	15:6	<b>Unused.</b>	—
	5	<b>Transmit_CHI_Interrupt_Mask.</b> 0 = The Transmit_CHI_Interrupt bit (see Table 6-11) will cause an interrupt if active. 1 = The Transmit_CHI_Interrupt bit is blocked from causing an interrupt.	1
	4	<b>Receive_CHI_Interrupt_Mask.</b> 0 = The Receive_CHI_Interrupt bit (see Table 6-11) will cause an interrupt if active. 1 = The Receive_CHI_Interrupt bit is blocked from causing an interrupt.	1
	3	<b>Unused.</b>	—
	2	<b>TPM_Interrupt_Mask.</b> 0 = The TPM_Interrupt bit (see Table 6-11) will cause an interrupt if active. 1 = The TPM_Interrupt bit is blocked from causing an interrupt.	1
	1	<b>SF_Interrupt_Mask.</b> 0 = The SF_Interrupt bit will (see Table 6-11) cause an interrupt if active. 1 = The SF_Interrupt bit is blocked from causing an interrupt.	1
	0	<b>CPU_Access_Interrupt_Mask.</b> 0 = The CPU_Access_Interrupt bit (see Table 6-11) will cause an interrupt if active. 1 = The CPU_Access_Interrupt bit is blocked from causing an interrupt.	1

Table 6-13. CPU\_Access\_Error (CORWN)

Address	Bit	Name/Description	Default
0x00008	15:4	<b>Unused.</b>	—
	3	<b>PLL_Lock_Error.</b> This bit indicates if the device's master PLL is locked to the incoming CHI reference clock (CHICLK). 0 = Locked. 1 = Not locked.	—
	2	<b>Access_Time_Out_Error.</b> 0 = No time-out. 1 = Indicates that a time-out has occurred internal to the TFRA84J13 device on a microprocessor access.	—
	1	<b>Invalid_Address_Error.</b> 0 = No invalid address. 1 = Indicates that a microprocessor access to an invalid address has occurred. The address causing this error can be found in the Invalid_Address_Trap register (see <a href="#">Table 6-18</a> ).	—
	0	<b>Data_Parity_Error.</b> 0 = No data parity error. 1 = Indicates that a microprocessor data bus parity error has occurred.	—

Table 6-14. CPU\_Access\_Error\_Mask (Read/Write)

Address	Bit	Name/Description	Default
0x0000A	15:4	<b>Unused.</b>	—
	3	<b>PLL_Lock_Error_Mask.</b> 0 = The PLL_Lock_Error bit (see <a href="#">Table 6-13</a> ) will cause an interrupt if active. 1 = The PLL_Lock_Error bit is blocked from causing an interrupt.	1
	2	<b>Access_Time-out_Error_Mask.</b> 0 = The Access_Time_Out_Error bit (see <a href="#">Table 6-13</a> ) will cause an interrupt if active. 1 = The Access_Time_Out_Error bit is blocked from causing an interrupt.	1
	1	<b>Invalid_Address_Error_Mask.</b> 0 = The Invalid_Address_Error bit will (see <a href="#">Table 6-13</a> ) cause an interrupt if active. 1 = The Invalid_Address_Error bit is blocked from causing an interrupt.	1
	0	<b>Data_Parity_Error_Mask.</b> 0 = The Data_Parity_Error bit will (see <a href="#">Table 6-13</a> ) cause an interrupt if active. 1 = The Data_Parity_Error bit is blocked from causing an interrupt.	1

Table 6-15. Global\_Control (Read/Write)

Address	Bit	Name/Description	Default
0x0000C	15	<b>Software_Reset.</b> This bit forces and holds the device in reset. 0 = Normal. 1 = Reset.	0
	14:9	<b>Unused.</b>	—
	8	<b>Reserved.</b>	—
	7:5	<b>Unused.</b>	—
	4	<b>DT_Wait_State_Control.</b> During write posting, a data transfer acknowledge ( $\overline{DT}$ ) can be generated on the first or second cycle following address strobe. If a $\overline{DT}$ immediately following address strobe is too fast for the microprocessor, then a single wait-state can be inserted. 0 = Zero wait-states inserted. 1 = One wait-state inserted.	1
	3	<b>Write_Posting_Enable.</b> This bit enables write posting, which will provide an early $\overline{DT}$ to the microprocessor. 0 = Write posting disabled. 1 = Write posting enabled.	0
	2	<b>Saturate_Rollover_Select.</b> This control bit changes the behavior of event counter registers. In saturation mode, a register will stick at the maximum value once it is reached. In roll-over mode, an event register will continue counting as its value cycles back to zero. 0 = Roll over. 1 = Saturation. When in saturate mode, the counters will operate in a clear-on-read mode. When in the roll-over mode, the counters will not be directly writable.	0
	1	<b>Data_Parity_Mode.</b> This bit controls the parity setting and checking on the microprocessor data bus. 0 = Even parity on microprocessor byte data/parity bus. 1 = Odd parity on microprocessor byte data/parity bus.	0
0	<b>Register_Clearing_Mode.</b> This bit controls the way clearing is performed on status bits in clear-on-read/clear-on-write registers. 0 = The status bit is cleared by writing a 1 to it. 1 = The status bit is cleared when a microprocessor read is performed.	0	

**Table 6-16. PLL\_Control (Read/Write)**

This register provides control over the PLL filter parameters. This register is unaffected by software reset.

Address	Bit	Name/Description	Default
0x0000E	15:11	<b>Unused.</b>	—
	10	<b>Reserved.</b>	—
	9:7	<b>Loop_Filter_Resistor.</b> These bits provide loop filter resistor control over the PLL. The loop filter damping resistor is approximately $(\text{Loop\_Filter\_Resistor} + 1) \times (20 \text{ k}\Omega)$ . This field is only enabled if <code>Enable_PLL_Control</code> is set to a 1. If <code>Enable_PLL_Control</code> is set to 0, default values are used within the PLL.	000
	6:4	<b>VCO_Gain_Control.</b> These bits provide control over the VCO gain in the PLL. The gain is approximately $(\text{VCO\_Gain\_Control} \times 100 \text{ MHz/V})$ . This field is only enabled if <code>Enable_PLL_Control</code> is set to 1. If <code>Enable_PLL_Control</code> is set to 0, default values are used within the PLL.	000
	3:1	<b>Charge_Pump_Current.</b> These bits provide control over the charge pump in the PLL. <code>Charge_Pump_Current</code> is approximately $(\text{Charge\_Pump\_Current} + 1) \times (2 \text{ }\mu\text{A})$ . This field is always enabled. The typical value is 0x4.	100
	0	<b>Enable_PLL_Control.</b> This bit is the master control for user programmability of the PLL loop parameters. If set to 1, the <code>VCO_Gain_Control</code> and <code>Loop_Filter_Resistor</code> bit fields in this register are allowed to serve as loop filter parameters for the PLL. If set to 0, these fields are ignored and the PLL uses default values.  0 = Disable user loop parameters. 1 = Enable user loop parameters.	0

**Table 6-17. Power\_Control (Read/Write)**

To minimize power consumption when parts of the device are not used in any given application, individual sections of the device may be powered off.

**Note:** All contents and information in a section that is powered off may be lost.

Address	Bit	Name/Description	Default
0x00010	15:1	<b>Unused.</b>	—
	0	<b>Data_Store_Enable.</b> This bit enables the data store. For low-power mode, the data store can be disabled. However, if the CHI interface is used, this bit should be set to 1. If none of the CHIs are used, this bit can be set to 0 to save power.  0 = Data store disabled. 1 = Data store enabled.	0

**Table 6-18. Invalid\_Address\_Trap (Read Only)**

Address	Bit	Name/Description	Default
0x00012	15:0	<b>Invalid_Address.</b> This register traps the value of an invalid address during a microprocessor access.	—

**Table 6-19. Scratch\_Register (Read/Write)**

Address	Bit	Name/Description	Default
0x00014	15:0	<b>Scratch_Pad.</b> This register is for test and diagnostics purposes. It is not connected to any internal functions. Therefore, it can be used during early testing to establish that the connections between the device and the microprocessor are intact, without affecting the configuration of the device.	0x0000

**Table 6-20. Reserved\_0 (Read/Write)**

This register is reserved for use by Agere Systems.

Address	Bit	Name/Description	Default
0x00016	15:3	Unused.	—
	2	Reserved.	—
	1:0	Unused.	—

## 6.6 Connection Store Generator Registers

The connection store is not initialized on powerup nor reset. Although it can be manually initialized by writing all locations via the microprocessor interface, the CSG is provided to independently fill the connection store with known data. The user can program the CSG to fill with a variety of patterns or with user-defined fixed data. Since the connection store is greater than 16 bits wide, the CSG, in general, has pairs of registers associated with controlling the data to be loaded.

**Table 6-21. CSG\_Control (Read/Write)**

This register provides general control over the CSG.

Address	Bit	Name/Description	Default
0x00400	15:4	Unused.	—
	3	<b>Enable_Stream_Switching.</b> Controls the enable for filling the Stream_Select field of the connection store.  0 = Stream switching is disabled. The Stream_Select field of the connection store RAM is filled with pseudorandom data. 1 = Enables stream switching. The Stream_Select fields of the connection store is filled with the contents of CS_Source_Stream_Select (see <a href="#">Table 6-33</a> ) for all time slots associated with the stream specified in CS_Destination_Stream_Select (see <a href="#">Table 6-33</a> ).  <b>Note:</b> In this mode, all other connection store RAM locations are filled with N-to-N mapping.	0
	2	<b>LFSR_Seed_Control.</b> Selects user-definable seed value or predefined seed value for the pseudorandom pattern generator.  0 = Default seed is loaded into the linear feedback shift register (LFSR) (0x3FFFFFFF). 1 = The 31-bit LFSR is loaded with the contents of the CSG_Seed registers.	0
	1	<b>CSG_Mode_Select.</b> Defines the type of pattern that will be filled into the connection store.  0 = Channel N to channel N mapping. 1 = Pseudorandom generated bit pattern (8-bit LFSR).	0
	0	<b>CSG_Enable.</b> Enables the pattern generator. After setting the other CSG registers, setting this bit to a 1 triggers the CSG to start programming of the connection store RAM.  0 = Pattern generator off. 1 = Pattern generator on.  <b>Note:</b> During the CSG operation, the function of the switch fabric is halted and the outputs of the CHIs and HSLs are nondeterministic. To reuse the CSG for subsequent programming of the connection store, this bit must be set back to 0 then to a 1.	0

**Table 6-22. CSG\_Status (Read Only)**

This register provides general status of the connection store generator.

Address	Bit	Name/Description	Default
0x00402	15:1	<b>Unused.</b>	—
	0	<b>CSG_Operation_Complete.</b> Pattern generation for connection and data store is complete. The bit is normally asserted, but it is deasserted when the CSG update is in progress. This status bit is cleared when the CSG_Enable bit (see <a href="#">Table 6-21</a> ) is cleared.  0 = Pattern generator is busy. 1 = Pattern generation is finished.	—

**Table 6-23. CSG\_Starting\_Address (Read/Write)**

This register defines the starting address of the connection store RAM for the CSG.

Address	Bit	Name/Description	Default
0x00404	15:13	<b>Unused.</b>	—
	12:0	<b>CSG_Start_Address.</b> Connection store updates will start at this address. To apply the start address to a single CS memory, disable the bit write enable register bits for the other CS memory.	0x0000

**Table 6-24. CSG\_Ending\_Address (Read/Write)**

This register defines the ending address of the connection store RAM for the CSG.

Address	Bit	Name/Description	Default
0x00406	15:13	<b>Unused.</b>	—
	12:0	<b>CSG_End_Address.</b> Connection store updates will end at this address. To apply the end address to a single CS memory, disable the bit write enable register bits for the other CS memory.	0x1FFF

**Table 6-25. CSG\_Write\_Enable\_Low (Read/Write)**

This register provides write enable control on a per-bit basis for the low word of the connection store when using the CSG to fill the connection store RAM.

Address	Bit	Name/Description	Default
0x00408	15:0	<b>CSG_Bit_Write_Enable_Low.</b> Controls writing of bits [15:0] in the connection store memory.  0 = Ignore the corresponding bit (this bit in memory maintains its present value). 1 = Write the corresponding bit.	0xFFFF

**Table 6-26. CSG\_Write\_Enable\_High (Read/Write)**

This register provides write enable control on a per-bit basis for the high word of the connection store when using the CSG to fill the connection store RAM.

Address	Bit	Name/Description	Default
0x0040A	15:0	<b>CSG_Bit_Write_Enable_High.</b> Controls writing of bits [31:16] in the connection store memory.  0 = Ignore the corresponding bit (this bit in memory maintains its present value). 1 = Write the corresponding bit.	0xFFFF

**Table 6-27. CSG\_Seed\_Low (Read/Write)**

Seed value for the pseudorandom pattern generator for the low word of the connection store RAM.

Address	Bit	Name/Description	Default
0x00410	15:0	<b>CSG_Seed_Low.</b> If the LFSR_Seed_Control bit (see <a href="#">Table 6-21</a> ) is asserted, at the beginning of a CSG operation, bits [15:0] of the LFSR supplying the connection store RAM with data are loaded with this programmable seed.	0xFFFF

**Table 6-28. CSG\_Seed\_High (Read/Write)**

Seed value for the pseudorandom pattern generator for the high word of the connection store RAM.

Address	Bit	Name/Description	Default
0x00412	15	<b>Unused.</b>	—
	14:0	<b>CSG_Seed_High.</b> If the LFSR_Seed_Control bit (see <a href="#">Table 6-21</a> ) is asserted, at the beginning of a CSG operation, bits [30:16] of the LFSR supplying the connection store RAM with data are loaded with this programmable seed.	0x7FFF

**Table 6-29. CSG\_OR\_Mask\_Low (Read/Write)**

This register allows bits in the connection store to be forced to 1. CS[15:0] = (pseudorandom data [15:0] OR CSG\_OR\_Mask\_Low) AND CSG\_AND\_Mask\_Low, bit enabled by CSG\_Write\_Enable\_Low.

Address	Bit	Name/Description	Default
0x00418	15:0	<b>CSG_OR_Mask_Low.</b> This register allows bit fields in the connection store to be forced to a one during a CSG fill operation. A bit-wise OR of this register and bits [15:0] of the pseudorandom generated data are performed to obtain the data for connection store. The resultant is then ANDed with CSG_AND_Mask_Low.	0x0000

**Table 6-30. CSG\_OR\_Mask\_High (Read/Write)**

This register allows bits in the connection store to be forced to 1. CS[31:16] = (pseudorandom data [31:16] OR CSG\_OR\_Mask\_High) AND CSG\_AND\_Mask\_High, bit enabled by CSG\_Write\_Enable\_High.

**Note:** CS[22:18] are always 0.

Address	Bit	Name/Description	Default
0x0041A	15:7	<b>CSG_OR_Mask_High_B.</b> This register allows bit fields in the connection store to be forced to a 1 during a CSG fill operation. A bit-wise OR of this register and bits [31:23] of the pseudorandom generated data are performed to obtain the data for connection store. The resultant is then ANDed with CSG_AND_Mask_High.	0x000
	6:2	<b>Unused.</b>	—
	1:0	<b>CSG_OR_Mask_High_A.</b> This register allows bit fields in the connection store to be forced to a 1 during a CSG fill operation. A bit-wise OR of this register and bits [17:16] of the pseudorandom generated data are performed to obtain the data for connection store. The resultant is then ANDed with CSG_AND_Mask_High.	00

**Table 6-31. CSG\_AND\_Mask\_Low (Read/Write)**

This register allows bits in the connection store to be forced to 0. This register takes precedence over CSG\_OR\_Mask\_Low. CS[15:0] = (pseudorandom data [15:0] OR CSG\_OR\_Mask\_Low) AND CSG\_AND\_Mask\_Low, bit enabled by CSG\_Write\_Enable\_Low.

Address	Bit	Name/Description	Default
0x0041C	15:0	<b>CSG_AND_Mask_Low.</b> This register allows bit fields in the connection store to be forced to a 0 during a CSG fill operation. A bit-wise AND of this register and bits [15:0] of the result from the OR of CSG_OR_Mask_Low with the pseudorandom generated data are performed to obtain the data for connection store.	0xFFFF

**Table 6-32. CSG\_AND\_Mask\_High (Read/Write)**

This register allows bits in the connection store to be forced to 0. This register takes precedence over CSG\_OR\_Mask\_High. CS[31:16] = (pseudorandom data [31:16] OR CSG\_OR\_Mask\_High) AND CSG\_AND\_Mask\_High, bit enabled by CSG\_Write\_Enable\_High.

**Note:** CS[22:18] are always 0.

Address	Bit	Name/Description	Default
0x0041E	15:7	<b>CSG_AND_Mask_High_B.</b> This register allows bit fields in the connection store to be forced to a 0 during a CSG fill operation. A bit-wise AND of this register and bits [31:23] of the result from the OR of CSG_OR_Mask_High with the pseudorandom generated data are performed to obtain the data for connection store.	0x1FF
	6:2	<b>Unused.</b>	—
	1:0	<b>CSG_AND_Mask_High_A.</b> This register allows bit fields in the connection store to be forced to a 0 during a CSG fill operation. A bit-wise AND of this register and bits [17:16] of the result from the OR of CSG_OR_Mask_High with pseudorandom generated data are performed to obtain the data for connection store.	11

**Table 6-33. CS\_Stream\_Control (Read/Write)**

If enabled, this register allows the CSG to program the connection store to map an incoming stream to an outgoing stream.

Address	Bit	Name/Description	Default
0x00428	15:13	<b>Unused.</b>	—
	12:8	<b>CS_Destination_Stream_Select.</b> Specifies destination channel in stream switching function. All time slots for this specified stream will be sourced from the stream specified in CS_Source_Stream_Select. The Enable_Stream_Switching control bit (see <a href="#">Table 6-21</a> ) must be set to enable this function.	0x00
	7:5	<b>Unused.</b>	—
	4:0	<b>CS_Source_Stream_Select.</b> Specifies the source stream in the stream switching function. All time slots for this stream will be sent to the stream specified by CS_Destination_Stream_Select. The Enable_Stream_Switching control bit (see <a href="#">Table 6-21</a> ) must be set to enable this function.	0x00

**Table 6-34. CSG\_Configuration (Read/Write)**

This register is used to populate the specified connection store RAM fields when the CSG is in the N-to-N mapping mode. This register is not used when in the LFSR pattern mode (see CSG\_Mode\_Select on [Table 6-21](#) bit 1).

Address	Bit	Name/Description	Default
0x0042A	15:11	<b>Reserved.</b>	00000
	10	<b>TPM_Enable_Field_Fill.</b> The Test_Pattern_Monitor_Enable field (see <a href="#">Table 8-2</a> ) in the connection store RAM is filled with this value.	0
	9:8	<b>Mode_Field_Fill.</b> The Time_Slot_Mode bits (see <a href="#">Table 8-2</a> ) in the connection store are filled with this pattern. 00 = Low latency. 01 = Frame integrity. 10 = Alternate data. 11 = TGP data.	00
	7	<b>High_Impedance_Control_Field_Fill.</b> Fills the Time_Slot_High_Impedance control bit (see <a href="#">Table 8-2</a> ) in the connection store.	0
	6:0	<b>Unused.</b>	—

## 6.7 Test Pattern Generator and Monitor Registers

**Table 6-35. TPG\_Configuration (Read/Write)**

The TPG can be configured to generate any one of the ITU-T test patterns specified in O.150, O.151, or O.152, as well as idle code or user-specified data.

Address	Bit	Name/Description	Default
0x00600	15:7	<b>Unused.</b>	—
	6	<b>TPG_Pattern_Invert.</b> Data output patterns are inverted when this bit is selected. 0 = Do not invert TPG data. 1 = Invert TPG data.	0
	5	<b>Enable_Error_Exercise.</b> This works in conjunction with both the TPG_Inject_Error_Count (see <a href="#">Table 6-40</a> ) and the Data_Invert_Mask (see <a href="#">Table 6-41</a> ). The latter is an 8-bit register that allows for bit-wise XORing of the data output. The former gets loaded with the number of N-bit errors that will be generated with N being the number bits set in the Data_Invert_Mask. If the Data_Invert_Mask is set to 0x00, then no errors will be injected despite the fact the TPG_Inject_Error_Count register will continue to decrement. 0 = Disable error exercising. 1 = Enable error exercise option.	0
	4	<b>Pattern_Generator_Enable.</b> Enable the pattern generator: 0 = Pattern generator off. 1 = Pattern generator on.  <b>Note:</b> Setting this bit to 0 will not reset the TPM_Error_Count (see <a href="#">Table 6-39</a> ) nor the Pattern_Error_Detected (see <a href="#">Table 6-42</a> ). Setting this bit to a 1 will reset the aforementioned.	0
	3:0	<b>TPG_Pattern_Select.</b> These bits select the test pattern to be generated and inserted into the selected time slots. Changing the pattern will reset the TPM_Error_Count register (see <a href="#">Table 6-39</a> ) and Pattern_Error_Detected (see <a href="#">Table 6-42</a> ). 0000 = Idle pattern (0011). 0001 = Mark (all ones AIS). 0010 = Alternating 0s and 1s—0x55. 0011 = $2^9 - 1$ . 0100 = $2^{11} - 1$ . 0101 = $2^{11} - 1$ with zero suppression when previous 7 bits are zero. 0110 = $2^{11} - 1$ with zero suppression when next 7 bits are zero. 0111 = $2^{15} - 1$ . 1000 = $2^{20} - 1$ . 1001 = QRSS ( $2^{20} - 1$ with zero suppression when the next 14 bits are zero). 1010 = QRSS ( $2^{20} - 1$ with zero suppression when the next 14 bits are zero). 1011 = $2^{23} - 1$ . 1100 = $2^{29} - 1$ . 1101 = $2^{31} - 1$ . 1110 = Indexed (data increments each time slot). 1111 = User pattern (repeating 2 bytes of data as specified in TPG_User_Pattern).	0x0

**Table 6-36. TPG\_User\_Pattern (Read/Write)**

Address	Bit	Name/Description	Default
0x00602	15:0	<b>TPG_User_Pattern.</b> Pattern-generator programmable user word. If pattern 0xF is specified by the TPG_Pattern_Select field, this data will be sent out as TPG data. Bit [15] gets transmitted first in time.	0x0000

**Table 6-37. TPM\_Configuration (Read/Write)**

The TPG can be configured to monitor any one of the ITU-T test patterns specified in O.150, O.151, or O.152, as well as idle code or user-specified data.

Address	Bit	Name/Description	Default
0x00604	15:7	<b>Unused.</b>	—
	6	<b>TPM_Pattern_Invert.</b> Incoming data patterns are inverted prior to checking when this bit is selected. 0 = Do not invert TPM data. 1 = Invert TPM data.	0
	5	<b>Reset_TPM_Error_Counter.</b> Resets the error counter (TPM_Error_Count see <a href="#">Table 6-39</a> ). 0 = Allow TPM_Error_Count to advance. 1 = Reset TPM_Error_Count (to zero).	0
	4	<b>Pattern_Monitor_Enable.</b> Enable the pattern monitor: 0 = Pattern monitor off. 1 = Pattern monitor on.	0
	3:0	<b>TPM_Pattern_Select.</b> These bits select the test pattern to be monitored from the selected time slots. 0000 = Idle pattern (0011). 0001 = Mark (all ones AIS). 0010 = Alternating 0s and 1s—0x55. 0011 = $2^9 - 1$ . 0100 = $2^{11} - 1$ . 0101 = $2^{11} - 1$ with zero suppression when previous 7 bits are zero. 0110 = $2^{11} - 1$ with zero suppression when next 7 bits are zero. 0111 = $2^{15} - 1$ . 1000 = $2^{20} - 1$ . 1001 = QRSS ( $2^{20} - 1$ with zero suppression when the next 14 bits are zero). 1010 = QRSS ( $2^{20} - 1$ with zero suppression when the next 14 bits are zero). 1011 = $2^{23} - 1$ . 1100 = $2^{29} - 1$ . 1101 = $2^{31} - 1$ . 1110 = Indexed (data increments each time slot). 1111 = User pattern (repeating 2 bytes of data as specified in TPM_User_Pattern).	0x0

**Table 6-38. TPM\_User\_Pattern (Read/Write)**

Address	Bit	Name/Description	Default
0x00606	15:0	<b>TPM_User_Pattern.</b> User-definable data for pattern monitoring. If pattern 0xF is specified by the TPM_Pattern_Select field, this data will be used to check against incoming data. Bit [15] gets checked first in time.	0x0000

Table 6-39. TPM\_Error\_Count (Sat/Roll\*)

Address	Bit	Name/Description	Default
0x00608	15:0	<p><b>TPM_Error_Count.</b> This status register accumulates the number of pattern bit errors detected in the monitored time slot(s).</p> <ul style="list-style-type: none"> <li>■ If Saturate_Rollover_Select (see Table 6-15) is set to a 1, this register will saturate at 0xFFFF and not be allowed to roll over.</li> <li>■ If Saturate_Rollover_Select is set to a 0, the counter will roll over (count to 0x0 on the next error after 0xFFFF), the Pattern_Error_Detected status bit (see Table 6-42) will not be reset.</li> </ul> <p>The TPM_Error_Count register can be reset in one of the following four ways:</p> <ol style="list-style-type: none"> <li>1. The pattern is changed.</li> <li>2. The bit RESET_TPM_Error_Counter (in the TPM_Configuration register, see Table 6-37) is asserted.</li> <li>3. This register is written. The TPM_Error_Count register will be set to 0x0000 independent of the value written.</li> <li>4. This register is read when Register_Clearing_Mode = 1 (see Table 6-15).</li> </ol> <p><b>Note:</b> Since TPM_Error_Count is the source of Pattern_Error_Detected status bit (see Table 6-42), then the clearing of this register will also clear the error bit.</p>	0x0000

\* See Table 6-15 bit 2.

Table 6-40. TPG\_Inject\_Error\_Count (Write Only)

Address	Bit	Name/Description	Default
0x0060A	15:0	<p><b>TPG_Inject_Error_Count.</b> This register specifies the number of errors to be injected. The actual number of bit errors that will be injected will equal to the TPG_Inject_Error_Count x N, where N is the number of bits set to 1 in the TPG_Data_Invert_Mask. The readback of this register will always reflect the remaining error count and not the original number written to this register.</p>	0x0000

This register provides a mask for specifying which bits of TPG data are to be inverted when forcing errors.

Table 6-41. TPG\_Data\_Invert\_Mask (Read/Write)

Address	Bit	Name/Description	Default
0x0060C	15:8	<b>Unused.</b>	—
	7:0	<p><b>Data_Invert_Mask.</b> The contents of this register are XORed with the TPG output word providing bit-wise error control.</p> <p><b>Note:</b> If Data_Invert_Mask = 0x00, then no errors will be injected.</p>	0x00

Table 6-42. TPM\_Status (Read Only)

Address	Bit	Name/Description	Default
0x0060E	15:2	<b>Unused.</b>	—
	1	<b>Test_Pattern_Lock.</b> This status bit indicates if the monitor has achieved a pattern lock on all selected time slots. 0 = Monitor is locked on the pattern. 1 = Monitor is searching for the pattern.	—
	0	<b>Pattern_Error_Detected.</b> This status bit indicates if the TPM_Error_Count register (see <a href="#">Table 6-39</a> ) is nonzero. 0 = No errors detected. 1 = Nonzero (one or more errors detected).  <b>Note:</b> This bit is cleared by clearing TPM_Error_Count. Refer to function description of TPM_Error_Count.	—

Table 6-43. TPM\_Status\_Mask (Read/Write)

Mask bits for the TPM\_Status register.

Address	Bit	Name/Description	Default
0x00610	15:2	<b>Unused.</b>	—
	1	<b>Test_Pattern_Lock_Mask.</b> This bit masks the Test_Pattern_Lock bit (see <a href="#">Table 6-42</a> ) from causing an interrupt. 0 = Nonmasked. If the monitor is not locked, an interrupt will be generated. 1 = Masked. An error will not cause an interrupt.	1
	0	<b>Pattern_Error_Mask.</b> This bit masks the Pattern_Error_Detected bit (see <a href="#">Table 6-42</a> ) from causing an interrupt. 0 = Nonmasked. An error will cause an interrupt. 1 = Masked. An error will not cause an interrupt.	1

## 6.8 Concentration Highway Configuration Registers

**Table 6-44. Receive\_CHI\_Configuration (Read/Write)**

Each of the incoming CHIs can be independently designed and programmed with a unique offset from the master frame synchronization. This bank of registers works in conjunction with the corresponding Receive\_CHI\_Time\_Slot\_Offset registers (see [Table 6-52](#)) to provide this control. These registers provide the bit and fractional bit offset control.

Address	Bit	Name/Description	Default
0x00A00—0x00A0E	15	<b>Receive_CHI_Loopback_Enable.</b> 0 = Input data for this receive CHI comes from the corresponding RXD pin. 1 = Input data for this receive CHI comes from the corresponding transmit CHI (see CHI_Feedback_Source_Selection in <a href="#">Table 6-48</a> bit 15).	0
	14:10	<b>Unused.</b>	—
	9:8	<b>Receive_CHI_Bit_Rate.</b> These bits indicate the data rate of this receive CHI. 00 = 2 Mbits/s. 01 = 4 Mbits/s. 10 = 8 Mbits/s. 11 = 16 Mbits/s. (Only valid with 16 MHz CHICLK clock.)	00
	7	<b>Unused.</b>	—
	6:4	<b>Receive_CHI_Bit_Offset.</b> These bits represent the bit offset relative to the frame synchronization sample point for this receive CHI (in binary, 0—7 bits).	000
	3:2	<b>Unused.</b>	—
	1	<b>Receive_CHI_Half_Bit_Offset.</b> 0 = No additional offset. 1 = Indicates an additional 1/2 bit of offset for this receive CHI.	0
	0	<b>Receive_CHI_Quarter_Bit_Offset.</b> 0 = No additional offset. 1 = Indicates an additional 1/4 bit of offset for this receive CHI.	0

**Table 6-45. Receive\_CHI\_Status (CORWN) Receive\_CHI\_Status (CORWN)**

Address	Bit	Name/Description	Default
0x00A80	15:3	<b>Unused.</b>	—
	2	<b>Receive_Clock_Error.</b> 0 = No clock error detected. 1 = Indicates a slow (or missing) CHICLK.	—
	1	<b>Receive_Lock_Error.</b> 0 = No clock error detected. 1 = Indicates a synchronization error has occurred between the CHICLK and the internal PLL clock. If Enable_Receive_CHI_Automatic_Resynchronization (see <a href="#">Table 6-47</a> ) is not a 1, then a manual resynchronization should be performed (Force_Receive_CHI_Resynchronization, see <a href="#">Table 6-47</a> ).	—
	0	<b>Receive_Frame_Sync_Error.</b> 0 = No frame synchronization error detected. 1 = Indicates a frame synchronization error has occurred. This means the CHI frame synchronization was either missing or misplaced. For missing frame synchronizations, this status is the only action taken. For misplaced frame synchronizations, the device automatically synchronizes to the new frame synchronization position.	—

**Table 6-46. Receive\_CHI\_Status\_Mask (Read/Write)**

Mask bits for the Receive\_CHI\_Status register (see Table 6-45).

Address	Bit	Name/Description	Default
0x00A82	15:3	<b>Unused.</b>	—
	2	<b>Receive_Clock_Error_Mask.</b> 0 = The Receive_Clock_Error bit (see Table 6-45) will cause an interrupt if active (unless masked at a higher level). 1 = The Receive_Clock_Error bit is blocked from causing an interrupt.	1
	1	<b>Receive_Lock_Error_Mask.</b> 0 = The Receive_Lock_Error bit (see Table 6-45) will cause an interrupt if active (unless masked at a higher level). 1 = The Receive_Lock_Error bit is blocked from causing an interrupt.	1
	0	<b>Receive_Frame_Sync_Error_Mask.</b> 0 = The Receive_Frame_Sync_Error bit (see Table 6-45) will cause an interrupt if active (unless masked at a higher level). 1 = The Receive_Frame_Sync_Error bit is blocked from causing an interrupt.	1

**Table 6-47. Receive\_CHI\_Global\_Configuration (Read/Write)**

Global configuration control for all the receive CHIs.

Address	Bit	Name/Description	Default
0x00A84	15:4	<b>Unused.</b>	—
	3	<b>Force_Receive_CHI_Resynchronization.</b> 0 = Normal operation. 1 = This forces the receive CHI/PLL interface to resynchronize.	0
	2	<b>Enable_Receive_CHI_Automatic_Resynchronization.</b> 0 = The device will inhibit automatic resynchronization of the receive CHI/PLL interface if it detects it is out-of-synchronization (not recommended). 1 = The device will automatically resynchronize the receive CHI/PLL interface if it detects it is out-of-synchronization.	0
	1	<b>Receive_Frame_Sync_Polarity.</b> This bit indicates the polarity of the frame synchronization signal. 0 = Indicates the frame synchronization is active-low. The reference point for all receive CHI timing is the first active edge of CHICLK (see Receive_Clock_Edge) after the frame synchronization transitions to the active level as defined here. 1 = Indicates the frame synchronization is active-high.	0
	0	<b>Receive_Clock_Edge.</b> This bit indicates which edge of the CHICLK to use to sample the frame synchronization signal. 0 = Indicates sampling on the falling edge. This also defines the reference point for all receive CHI timing and offsets. 1 = Indicates sampling on the rising edge of the clock.	0

Table 6-48. Transmit\_CHI\_Configuration (Read/Write)

Each of the incoming CHIs can be independently designed and programmed with a unique offset from the master frame synchronization. This bank of registers works in conjunction with the corresponding Transmit\_CHI\_Time\_Slot\_Offset registers (see Table 6-53) to provide this control. These registers provide the bit and fractional bit offset control.

Address	Bit	Name/Description	Default
0x00C00—0x00C0E	15	<b>CHI_Feedback_Source_Selection.</b> Selects which data is sent to corresponding receive CHI. 0 = Means pre-output data is sent. 1 = Means the input from the bidirectional TXD pin is sent. This bit has no effect unless the corresponding receive CHI's Receive_CHI_Loopback_Enable bit is one (see Table 6-44).	0
	14	<b>Unused.</b>	—
	13:12	<b>Driver_Enable_Control.</b> These two bits determine how the output TXD pin is actually driven. 00 = Always disabled. 01 = Based on time-slot programming (timing from CHICLK). 10 = Reserved. 11 = Similar to 01 except all time slots are disabled near end of time slot (see Transmit_High_Impedance_Delay in Table 6-51 bits [6:4]).	00
	11:10	<b>Unused.</b>	—
	9:8	<b>Transmit_CHI_Bit_Rate.</b> These bits indicate the data rate of this transmit CHI. 00 = 2 Mbits/s. 01 = 4 Mbits/s. 10 = 8 Mbits/s. 11 = 16 Mbits/s (only valid with 16 MHz CHICLK).	00
	7	<b>Unused.</b>	—
	6:4	<b>Transmit_CHI_Bit_Offset.</b> These bits represent the bit offset relative to the frame synchronization sample point for this transmit CHI (in binary, 0—7 bits).	000
	3:2	<b>Unused.</b>	—
	1	<b>Transmit_CHI_Half_Bit_Offset.</b> 0 = No additional delay. 1 = Indicates an additional 1/2 bit of offset for this transmit CHI.	0
	0	<b>Transmit_CHI_Quarter_Bit_Offset.</b> 0 = No additional delay. 1 = Indicates an additional 1/4 bit of offset for this transmit CHI. This bit must be 0 when the CHI rate is 16 Mbits/s or when the CHI rate is 8 Mbits/s mode and the CHICLK is 8.192 MHz.	0

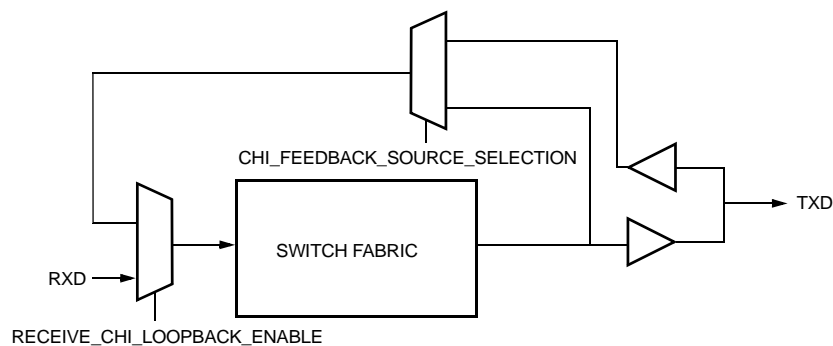

Figure 6-1. Transmit CHI Configuration (R/W)

Table 6-49. Transmit\_CHI\_Status (CORWN)

Address	Bit	Name/Description	Default
0x00C80	15:2	<b>Unused.</b>	—
	1	<b>Transmit_Lock_Error.</b> 0 = No error detected. 1 = Indicates a synchronization error has occurred between the CHICLK and the internal PLL clock. If Enable_Transmit_CHI_Automatic_Resynchronization is not a 1 (see <a href="#">Table 6-51</a> ), then a manual resynchronization should be performed (Force_Transmit_CHI_Resynchronization, see <a href="#">Table 6-51</a> ).	—
	0	<b>Transmit_Frame_Sync_Error.</b> 0 = No error detected. 1 = Indicates a frame synchronization error has occurred in the transmit CHI section of the device. This means the CHI frame synchronization was either missing or misplaced. For missing frame synchronizations, this status is the only action taken. For misplaced frame synchronizations, the device automatically synchronizes to the new frame synchronization position.	—

Table 6-50. Transmit\_CHI\_Status\_Mask (Read/Write)

Mask register for the Transmit\_CHI\_Status register.

Address	Bit	Name/Description	Default
0x00C82	15:2	<b>Unused.</b>	—
	1	<b>Transmit_Lock_Error_Mask.</b> 0 = The Transmit_Lock_Error bit (see <a href="#">Table 6-49</a> ) will cause an interrupt if active (unless masked at a higher level). 1 = The Transmit_Lock_Error bit is blocked from causing an interrupt.	1
	0	<b>Transmit_Frame_Sync_Error_Mask.</b> 0 = The Transmit_Frame_Sync_Error bit (see <a href="#">Table 6-49</a> ) will cause an interrupt if active (unless masked at a higher level). 1 = The Transmit_Frame_Sync_Error bit is blocked from causing an interrupt.	1

Table 6-51. Transmit\_CHI\_Global\_Configuration (Read/Write)

Address	Bit	Name/Description	Default
0x00C84	15:8	<b>Unused.</b>	—
	7	<b>Global_Transmit_CHI_Output_Enable.</b> This bit is a global control over the 3-state enables of the transmit CHIs. 0 = All CHIs transmit pins are forced into the high-impedance state. 1 = 3-state control of individual CHIs is placed under control of the CHI Transmit_CHI_Configuration registers (see <a href="#">Table 6-48</a> ).	0
	6:4	<b>Transmit_High_Impedance_Delay.</b> These bits are used in conjunction with Driver_Enable_Control (see <a href="#">Table 6-48</a> bits [13:12]) bits. When the Driver_Enable_Control bits = 11, then the Transmit_High_Impedance_Delay bits determine how early the device will 3-state the output driver at the end of a time slot. These numbers are approximate because of the sampling error between the CHICLK and the internal clock. The numbers are actually how much time <b>after</b> the previous clock edge the output 3-states. For bit settings [6:4]:  000 = Approximately 55 ns after the previous same edge with a 16.384 MHz CHICLK. = Approximately 55 ns after the previous opposite edge with an 8.192 MHz CHICLK. 001 = Approximately 49 ns after the previous same edge with a 16.384 MHz CHICLK. = Approximately 49 ns after the previous opposite edge with an 8.192 MHz CHICLK. 010 = Approximately 43 ns after the previous same edge with a 16.384 MHz CHICLK. = Approximately 43 ns after the previous opposite edge with an 8.192 MHz CHICLK. 011 = Approximately 37 ns after the previous same edge with a 16.384 MHz CHICLK. = Approximately 37 ns after the previous opposite edge with an 8.192 MHz CHICLK. 100 = Approximately 116 ns after the previous same edge (8.192 MHz CHICLK only). 101 = Approximately 110 ns after the previous same edge (8.192 MHz CHICLK only). 110 = Approximately 104 ns after the previous same edge (8.192 MHz CHICLK only). 111 = Approximately 98 ns after the previous same edge (8.192 MHz CHICLK only).  See <a href="#">Figure 5-15 on page 27</a> and <a href="#">Table 5-5 on page 27</a> .	000
	3	<b>Force_Transmit_CHI_Resynchronization.</b> 0 = Normal operation. 1 = This forces the transmit CHI/PLL interface to resynchronize.	0
	2	<b>Enable_Transmit_CHI_Automatic_Resynchronization.</b> 0 = The device will inhibit automatic resynchronization of the transmit CHI/PLL interface if it detects it is out-of-synchronization (not recommended). 1 = The device will automatically resynchronize the CHI/PLL interface if it detects it is out-of-synchronization.	0
	1	<b>Transmit_Frame_Sync_Polarity.</b> This bit indicates the polarity of the frame synchronization signal. 0 = Indicates the frame synchronization is active-low. Generally, this should be programmed with the same value as Receive_Frame_Sync_Polarity (see <a href="#">Table 6-47</a> ). The reference point for all receive CHI timing is the first active edge of CHICLK (see Transmit_Clock_Edge) after the frame synchronization transitions to the active level as defined here. 1 = Indicates the frame synchronization is active-high.	0
	0	<b>Transmit_Clock_Edge.</b> This bit indicates which edge of the CHICLK to use to sample the frame synchronization signal. 0 = Indicates sampling on the falling edge. Generally, this should be programmed with the same value as Receive_Clock_Edge (see <a href="#">Table 6-47</a> ). This also defines the reference point for all transmit CHI timing and offsets. 1 = Indicates sampling on the rising edge of the clock.	0

**Table 6-52. Receive\_CHI\_Time\_Slot\_Offset (Read/Write)**

Each of the incoming CHIs can be independently designed and programmed with a unique offset from the master frame synchronization. This bank of registers works in conjunction with the corresponding Receive\_CHI\_Configuration registers (see [Table 6-44](#)) to provide this control. These registers provide the time-slot offset. The Receive\_CHI\_Configuration registers provide the bit and fractional bit offset control.

Address	Bit	Name/Description	Default	
0x01000—0x0100E	15:8	<b>Unused.</b>	—	
	7:0	<b>Receive_CHI_Offset.</b> Time-slot offset for the receive CHIs. This value should be programmed as follows (RTO = the number of receive time slots to be offset):	—	
		<b>CHI Rate</b>	<b>Offset</b>	<b>RC_TS_OFF Value</b>
		16 Mbits/s	RTO (0—255)	RTO
		8 Mbits/s	RTO (0—127)	$((RTO \times 2) + 2)$ modulo 256
		4 Mbits/s	RTO (0—63)	$((RTO \times 4) + 6)$ modulo 256
2 Mbits/s	RTO (0—31)	$((RTO \times 8) + 14)$ modulo 256		

**Table 6-53. Transmit\_CHI\_Time\_Slot\_Offset (Read/Write)**

Each of the outgoing CHIs can be independently designed and programmed with a unique offset from the master frame synchronization. This bank of registers works in conjunction with the corresponding Transmit\_CHI\_Configuration registers (see [Table 6-48](#)) to provide this control. These registers provide the time-slot offset. The Transmit\_CHI\_Configuration registers provide the bit and fractional bit offset control.

Address	Bit	Name/Description	Default	
0x01080—0x0108E	15:8	<b>Unused.</b>	—	
	7:0	<b>Transmit_CHI_Offset.</b> Time-slot offset for the transmit CHIs. This value should be programmed as follows (TTO = the number of transmit time slots to be offset):	—	
		<b>CHI Rate</b>	<b>Offset</b>	<b>TC_TS_OFF Value</b>
		16 Mbits/s	TTO (0—255)	TTO
		8 Mbits/s	TTO (0—127)	TTO x 2
		4 Mbits/s	TTO (0—63)	TTO x 4
2 Mbits/s	TTO (0—31)	TTO x 8		

## 7 Switch Fabric Control

Table 7-1. SF\_Status (CORWN)

Address	Bit	Name/Description	Default
0x01124	15:3	<b>Unused.</b>	—
	2	<b>Receive_Link_Synchronization_Error.</b> 0 = No error detected. 1 = Missing or misplaced synchronization on interface between the receive CHI and the switch fabric (clear-on-read/clear-on-write).	—
	1	<b>Transmit_Sync_Error.</b> 0 = No error detected. 1 = Missing or misplaced synchronization on interface between the transmit CHI and the switch fabric (clear-on-read/clear-on-write).	—
	0	<b>Connection_Store_Parity_Error.</b> 0 = No error detected. 1 = Connection store parity error detected (read only, clear by clearing Connection_Store_Parity_Error_Address_Trap, see <a href="#">Table 7-5</a> ). The location with the parity error can be found in Connection_Store_Parity_Error_Address_Trap.	—

Table 7-2. SF\_Status\_Mask (Read/Write)

Provides a mask for all bits in the SF\_Status register (see Table 7-1). These bits are output masks of the register. That is, setting the mask will not stop the error bit from being set, but will block an interrupt from being propagated if the corresponding error is set.

Address	Bit	Name/Description	Default
0x01126	15:3	<b>Unused.</b>	—
	2	<b>Receive_Link_Synchronization_Error_Mask.</b> 0 = Unmasked, Receive_Link_Synchronization_Error will (see Table 7-1) cause interrupt (unless masked at higher level). 1 = Masked, Receive_Link_Synchronization_Error will not cause an interrupt.	1
	1	<b>Transmit_Sync_Error_Mask.</b> 0 = Unmasked, Transmit_Sync_Error (see Table 7-1) will cause interrupt (unless masked at higher level). 1 = Masked, Transmit_Sync_Error will not cause an interrupt.	1
	0	<b>Connection_Store_Parity_Error_Mask.</b> 0 = Unmasked, Connection_Store_Parity_Error (see Table 7-1) will cause interrupt (unless masked at higher level). 1 = Masked, Connection_Store_Parity_Error will not cause an interrupt.	1

**Table 7-3. Data\_Store\_Time\_Slot\_Capture\_Select (Read/Write)**

For diagnostic and other purposes, a single incoming time slot can be sampled and made available to be read from the microprocessor interface. This register specifies which time slot will be sampled.

Address	Bit	Name/Description	Default
0x01142	15:13	<b>Unused.</b>	—
	12:0	<p><b>Data_Store_Time_Slot_Capture.</b> Specifies which time slot should be captured (sampled) (0—8,191). This value is a function of the stream (CHI) number, the data rate of the CHI, the time-slot offset of the CHI (RTO), and the desired time slot (TS) of the CHI. The following algorithms can be used to determine the value for this field:</p> <ul style="list-style-type: none"> <li>■ For a 16 Mbits/s CHI: — <math>(32 \times [(TS + RTO) \bmod 256]) + CHI</math>, where TS and RTO range from 0—255.</li> <li>■ For an 8 Mbits/s CHI: — <math>(32 \times [(2 \times (TS + RTO)) + 2] \bmod 256) + CHI</math>, where TS and RTO range from 0—127.</li> <li>■ For a 4 Mbits/s CHI: — <math>(32 \times [(4 \times (TS + RTO)) + 6] \bmod 256) + CHI</math>, where TS and RTO range from 0—63.</li> <li>■ For a 2 Mbits/s CHI: — <math>(32 \times [(8 \times (TS + RTO)) + 14] \bmod 256) + CHI</math>, where TS and RTO range from 0—31.</li> </ul>	0x0000

**Table 7-4. Data\_Store\_Captured\_Data (Read Only)**

This register contains data sampled in two consecutive frames from the time slot specified in Data\_Store\_Time\_Slot\_Capture, see Table 7-3. This register is continually updated every frame (alternating high/low byte each frame).

Address	Bit	Name/Description	Default
0x01144	15:8	<b>Captured_Data_1.</b> Data captured from the time slot specified by Data_Store_Time_Slot_Capture (see Table 7-3). This field is updated every other frame alternating with Captured_Data_0. Depending on when this is read by the microprocessor, it may be either from the frame before or after that sampled in Captured_Data_0.	—
	7:0	<b>Captured_Data_0.</b> Data captured from the time slot specified by Data_Store_Time_Slot_Capture (see Table 7-3). This field is updated every other frame alternating with Captured_Data_1. Depending on when this is read by the microprocessor, it may be either from the frame before or after that sampled in Captured_Data_1.	—

**Table 7-5. Connection\_Store\_Parity\_Error\_Address\_Trap (CORWN)**

As the connection store is continually read, its parity is checked. If an error is detected, the location with the error is saved in this register and the Connection\_Store\_Parity\_Error (see Table 7-1) error bit is set. If in clear-on-read (COR) mode, when this register is read, the Connection\_Store\_Parity\_Error bit is cleared. If in clear-on-write (COW) mode, any write to this register clears Connection\_Store\_Parity\_Error.

Address	Bit	Name/Description	Default
0x01146	15	<b>Unused.</b>	—
	14:0	<b>Connection_Store_Parity_Error_Address.</b> This bit field contains the address within the connection store with a parity error. The address of the first error (after a clear) is sampled and saved.	—

**Table 7-6. Receive\_Link\_Offset (Read Only)**

This register displays the offset of the receive link with respect to the switch fabric. See also Transmit\_Link\_Offset and Force\_Transmit\_Link\_Offset in Table 7-7.

Address	Bit	Name/Description	Default
0x01148	15:12	<b>Unused.</b>	—
	11:0	<b>Link_Offset.</b> This field contains the time-slot offset of the receive link.	—

**Table 7-7. Transmit\_Link\_Offset (Read/Write)**

This register displays/controls the offset of the transmit links with respect to the switch fabric. Normally, the Transmit\_Link\_Offset is determined by the CHI frame synchronization's relative position to the switch fabric synchronization. In this case, bit [15] of this register should be set to 0.

Address	Bit	Name/Description	Default
0x0114C	15	<b>Force_Transmit_Link_Offset.</b> 0 = Allows the switch fabric to self-determine its offsets. 1 = Forces the device to use the Transmit_Offset value to align the switch fabric to a deterministic position relative to the CHI frame synchronization. If this is set to 1, this register value should be set and the system allowed to stabilize (more than 250 $\mu$ s) prior to reading the value in Receive_Link_Offset (see Table 7-6).	—
	14:12	<b>Unused.</b>	—
	11:0	<b>Transmit_Offset.</b> If Force_Transmit_Link_Offset is set to 1, this value will force the switch fabric to align itself this many time slots off from the CHI frame synchronization. Please contact your FAE if you plan on using this feature.	—

**Table 7-8. Wide\_Mode\_Control (Read/Write)**

For applications that require switching of time slots of greater than 8 bits, parallel devices must be used. These bits can be used to facilitate such operation. Please contact your FAE if setting these bits to other than the default value of 0.

Address	Bit	Name/Description	Default
0x0114E	15:3	<b>Unused.</b>	—
	2:0	<b>Wide_Mode_Operation.</b>  000 = Disable multifabric synchronization (i.e., normal mode) (default). 001 = Software algorithm mode, maximum allowable receive delay of approximately 7 $\mu$ s. 010 = Software algorithm mode, maximum allowable receive delay of approximately 15 $\mu$ s. 011 = Software algorithm mode, maximum allowable receive delay of approximately 31 $\mu$ s. 100 = Disable multifabric synchronization (i.e., normal mode). 101 = Minimal latency mode, maximum allowable receive delay of approximately 7 $\mu$ s. 110 = Minimal latency mode, maximum allowable receive delay of approximately 15 $\mu$ s. 111 = Minimal latency mode, maximum allowable receive delay of approximately 31 $\mu$ s.  <b>Note:</b> For the last three modes, the minimum, average, and maximum delay in low-latency (LL) mode will be up to 7 $\mu$ s, 15 $\mu$ s, and 31 $\mu$ s larger than regular LL mode. For the software modes, the minimum delay in LL mode will be up to 7 $\mu$ s, 15 $\mu$ s, and 31 $\mu$ s larger, and the maximum delay will be up to 132 $\mu$ s, 140 $\mu$ s, and 156 $\mu$ s larger than regular mode.	000

## 8 Connection Store

The connection store RAM contains the per-time-slot control information for outgoing time slots. Each location in the RAM corresponds to one outgoing time slot and contains all the time-slot specific control information for that time slot. The specific address offset into the RAM is calculated as follows:

- ADDR[15] = 0.
- ADDR[14:7] destination (outgoing) time-slot number of stream identified by address bits [6:2].
- ADDR[6:2] destination (outgoing) stream (CHI) number.
- ADDR[01] 0 = Low\_Control, 1 = High\_Control.
- ADDR[00] = 0 (no byte addressability).

Address bits [14:7] are dependent on the destination (outgoing) CHI rate and should be calculated as follows, where TS is the outgoing CHI time-slot number:

Rate	A[14:7]
16 MHz	TS (0—255)
8 MHz	TS x 2 (TS = 0—127)
4 MHz	TS x 4 (TS = 0—63)
2 MHz	TS x 8 (TS = 0—31)

**Table 8-1. Low\_Control\_Word (Read/Write)**

The low-control word in the connection store has two functions. Normally, it is used to program the address of the incoming time slot to which the outgoing time slot is connected. The outgoing time slot is implied by the connection store address as described above. This normal switch operation will apply if the time-slot mode bits in the high-control word are set to low latency or frame integrity switching modes. If alternate data mode is selected, the low control word contains the alternate data (see [Table 8-2](#), bit [9:8]).

Address	Bit*	Name/Description	Default
0x10000— 0x11FFC	15:8	<b>Alternate_Data_Pattern_2.</b> If alternate data is selected by the mode bits in the corresponding high control location, the data in this byte will alternate with the Alternate_Data_Pattern_1 pattern and be sent out on the transmit time slot.	—
	12:5	<b>Time_Slot_Pointer.</b> This field selects the desired time slot from the source stream (CHI). This value is dependent on the speed (data rate) of the receive CHI specified by Stream_Pointer and should be programmed as follows, where TS is the desired time-slot number:	—
		<b>Receive CHI Rate</b>	<b>Time_Slot_Pointer [7:0]</b>
		16 Mbits/s	TS (0—255)
		8 Mbits/s	TS x 2 (TS = 0—127)
		4 Mbits/s	TS x 4 (TS = 0—63)
2 Mbits/s	TS x 8 (TS = 0—31)		
7:0	<b>Alternate_Data_Pattern_1.</b> If alternate data is selected by the mode bits in the corresponding high control location, the data in this byte will alternate with the Alternate_Data_Pattern_2 pattern and be sent out on the transmit time slot.	—	
4:0	<b>Stream_Pointer.</b> This field selects one of 32 incoming streams.	—	

\* Bits [15:0] have dual meaning based on the value in the Time\_Slot\_Mode field of the High\_Control\_Word (see [Table 8-2](#)).

If the Time\_Slot\_Mode field is set to 10 (alternate data), then bits [15:0] have the following meaning:

Bits [7:0] are set to Alternate\_Data\_Pattern\_1.

Bits [15:8] are set to Alternate\_Data\_Pattern\_2.

If the Time\_Slot\_Mode field is set to anything other than 10, then bits [15:0] have the following meaning:

Bits [4:0] are set to Stream\_Pointer.

Bits [12:5] are set to Time\_Slot\_Pointer.

Bits [15:13] are reserved.

Table 8-2. High\_Control\_Word (Read/Write)

Address	Bit	Name/Description	Default
0x10002—0x11FFE	15:11	<b>Reserved.</b>	0x0
	11	<b>Reserved.</b>	—
	10	<b>Test_Pattern_Monitor_Enable.</b> 0 = The TPM is disable for this time slot. 1 = This bit causes data for this time slot to be sent to the test pattern monitor for checking.	—
	9:8	<b>Time_Slot_Mode.</b> This field defines in which of the following modes the time slot will operate: 00 = Low latency. 01 = Frame integrity. 10 = Alternate data. 11 = TPG data.	—
	7	<b>Reserved.</b> <b>Note:</b> This bit must be set to zero.	—
	6:5	<b>Unused.</b>	—
	4	<b>General_Purpose_Bit.</b> This is a general-purpose read/write bit. It causes no action within the device.	—
	3:0	<b>Unused.</b>	—

## 9 Outline Diagrams

Note: Dimensions are in millimeters.

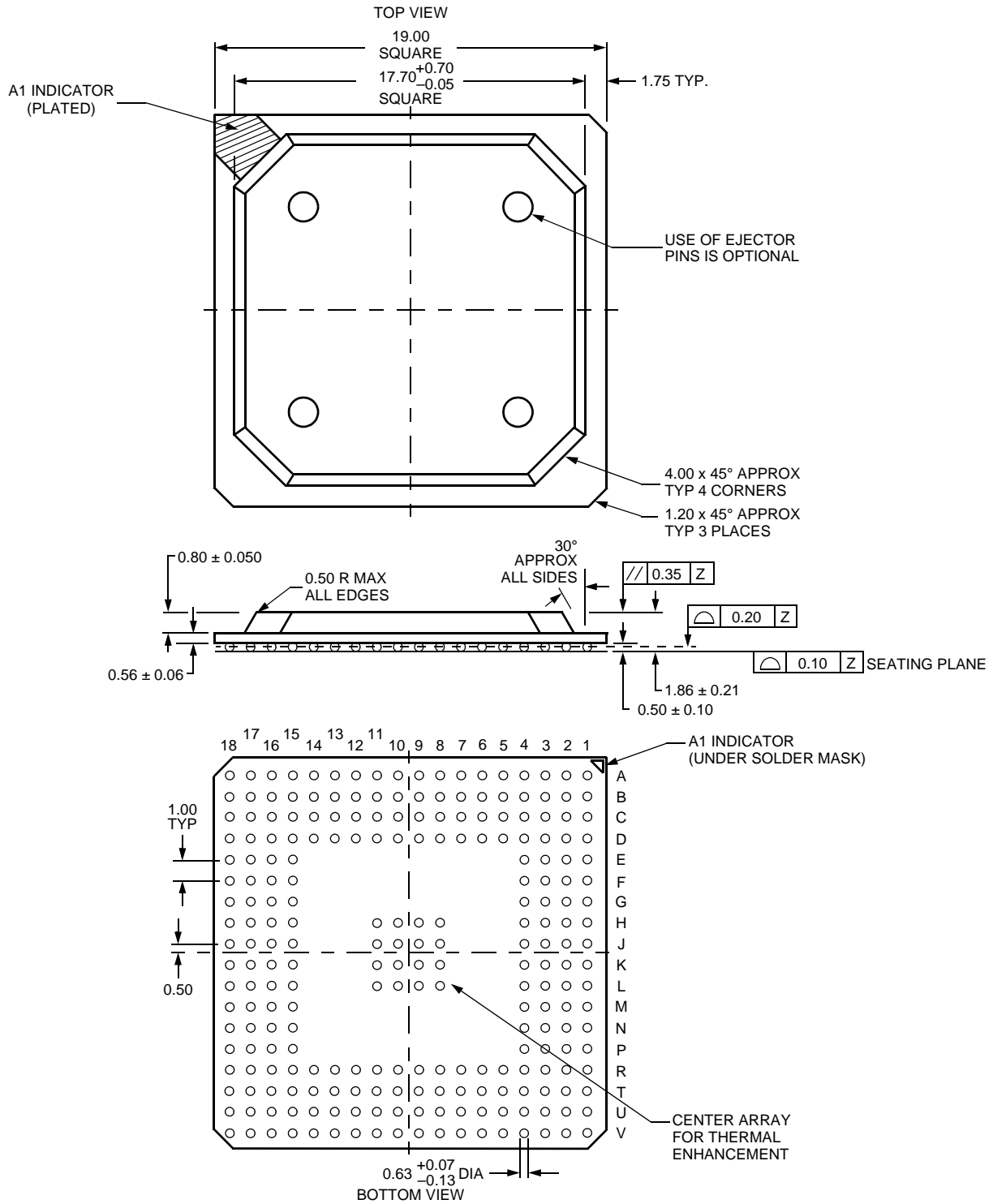

## 10 Ordering Information

Device	Part Number	Ball Count	Package	Comcode
TTSI002081	TTSI002081BL-2	240	PBGAM1	700081609
	L-TTSI002081BL-2			700081545*

\* Pb-free/RoHS.

Adobe Acrobat and Acrobat Reader are registered trademarks of Adobe Systems Incorporated.

For additional information, contact your Agere Systems Account Manager or the following:

INTERNET: Home: <http://www.agere.com> Sales: <http://www.agere.com/sales>

E-MAIL: [docmaster@agere.com](mailto:docmaster@agere.com)

N. AMERICA: Agere Systems Inc., Lehigh Valley Central Campus, Room 10A-301C, 1110 American Parkway NE, Allentown, PA 18109-9138

1-800-372-2447, FAX 610-712-4106 (In CANADA: 1-800-553-2448, FAX 610-712-4106)

ASIA: CHINA: (86) 21-54614688 (Shanghai), (86) 755-25881122 (Shenzhen)

JAPAN: (81) 3-5421-1600 (Tokyo), KOREA: (82) 2-767-1850 (Seoul), SINGAPORE: (65) 6741-9855, TAIWAN: (886) 2-2725-5858 (Taipei)

EUROPE: Tel. (44) 1344 296 400

Agere Systems Inc. reserves the right to make changes to the product(s) or information contained herein without notice. No liability is assumed as a result of their use or application. Agere, Agere Systems, and the Agere logo are registered trademarks of Agere Systems Inc.