

SERIAL I/O REAL TIME CLOCK

■ GENERAL DESCRIPTION

The NJU6355 is a serial I/O Real Time Clock suitable for 4 bit microprocessors.

It contains a quartz crystal oscillator, counter, shift register, voltage regulator, voltage detector, and interface controller.

Only 4 lines are required for serial time, calendar and alarm data transfer between NJU6355 and microprocessor, and the microprocessor can receive their data any time when the microprocessor is required.

The operating voltage is as wide as 1.2V to 5.0V, consequently, the NJU6355 can count accurate time data even if the back up period.

Furthermore, the long time back up is available because of the current consumption during the back up period is less than 1uA.

■ PACKAGE OUTLINE

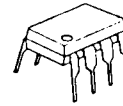

NJU6355D



NJU6355M

■ FEATURES

- Operating Voltage : 1.2 ~ 5.5V
- Low operating current : 1uA typ. at 1.2V  
30uA typ. at 5.0V
- BCD Counts of, Seconds, Minutes, Hours, Date, Days of Week, Month and Year
- Only 4 lines (DATA, CLK, CE and I/O) required
- Low Voltage Detector (Low voltage alarm signal output)
- Automatic Leap Year Compensation
- Package Outline --- DIP8/DMP8
- C-MOS Technology

■ PIN CONFIGURATION

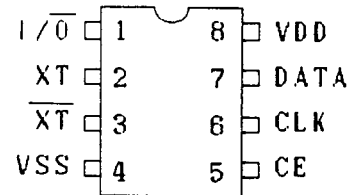

■ LINE UP

Version	Output DATA	OSC. Capacitor
6355 A	Seconds, Minutes, Hours, Date, Days of Week, Month, Year	C <sub>o</sub> /C <sub>d</sub> on chip
B	Date, Days of Week, Month, Year	C <sub>o</sub> /C <sub>d</sub> on chip
C	Seconds, Minutes, Hours, Date, Days of Week, Month, Year	Only C <sub>o</sub>
D	Date, Days of Week, Month, Year	Only C <sub>o</sub>

■ BLOCK DIAGRAM

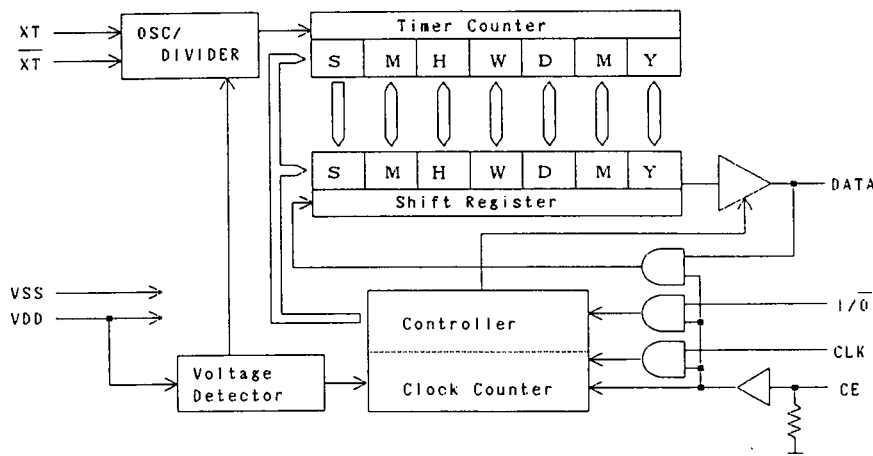

## ■ APPLICATION CIRCUIT

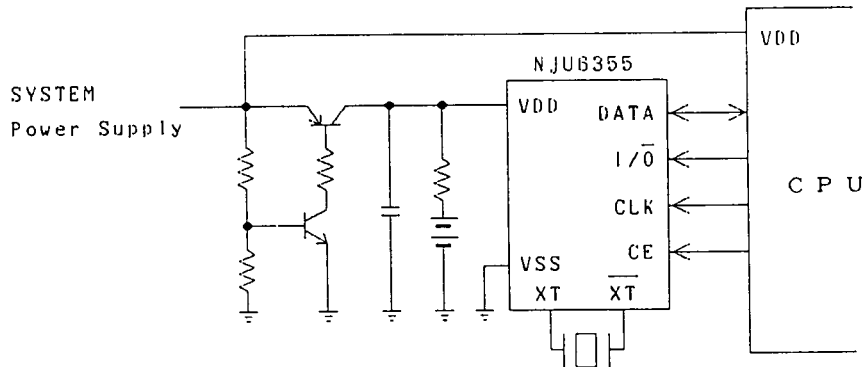

## ■ ABSOLUTE MAXIMUM RATINGS

 (  $T_a=25^\circ\text{C}$  )

PARAMETER	SYMBOL	RATINGS	UNIT
Supply Voltage	$V_{DD}$	- 0.3 ~ + 6.0	V
Input Voltage	$V_{IN}$	$V_{SS}-0.3 \sim V_{DD}+0.3$	V
Power Dissipation	$P_D$	DIP-250    DMP-200	mW
Operating Temperature	$T_{opr}$	0 ~ 70	$^\circ\text{C}$
Storage Temperature	$T_{stg}$	- 55 ~ +150	$^\circ\text{C}$

## ■ ELECTRICAL CHARACTERISTICS

 (  $V_{DD}=1.2V \pm 10\%$ ,  $T_a=0 \sim 70^\circ\text{C}$  )

PARAMETER	SYMBOL	CONDITIONS	MIN	TYP	MAX	UNIT
Operating Current	$I_{DD}$	$XT=32.768\text{kHz}, CE=V_{IL}$			1.0	$\mu\text{A}$
Input Voltage	$V_{IH}$	$I/\bar{O}, CE, CLK, DATA$	0.96		$V_{DD}$	V
	$V_{IL}$	$I/\bar{O}, CE, CLK, DATA$	$V_{SS}$		0.24	
Detection Voltage	$V_{DET}$	$V_{DD}=1.2V, T_a=25^\circ\text{C}$	0.7		0.9	V

 (  $V_{DD}=5.0V \pm 10\%$ ,  $T_a=0 \sim 70^\circ\text{C}$  )

PARAMETER	SYMBOL	CONDITIONS	MIN	TYP	MAX	UNIT
Operating Voltage	$V_{DD}$		4.5		5.5	V
Operating Current	$I_{DD}$	$XT=32.768\text{kHz}, CE=V_{IL}$			30	$\mu\text{A}$
3-st Leakage Current	$I_{TSL}$	$DATA(CE=V_{IL})$	-2.0		2.0	$\mu\text{A}$
Input Leakage Current	$I_{IL}$	$I/\bar{O}, CE, CLK$	-1.0		1.0	$\mu\text{A}$
	$V_{IH}$	$I/\bar{O}, CE, CLK, DATA$	$V_{DD} \times 0.8$		$V_{DD}$	
Input Voltage	$V_{IL}$	$I/\bar{O}, CE, CLK, DATA$	$V_{SS}$		$V_{SS} \times 0.2$	V
	$V_{OH}$	$DATA(I_{OH}=-0.4\text{mA})$	4.1			
Output Voltage	$V_{OL}$	$DATA(I_{OL}=1.0\text{mA})$			0.4	V