

3.3 V 1:8 LVCMOS PLL Clock Generator

The MPC9653A is a 3.3 V compatible, 1:8 PLL based clock generator and zero-delay buffer targeted for high performance low-skew clock distribution in mid-range to high-performance telecom, networking and computing applications. With output frequencies up to 125 MHz and output skews less than 150 ps the device meets the needs of the most demanding clock applications.

Features

- 1:8 PLL based low-voltage clock generator
- Supports zero-delay operation
- 3.3 V power supply
- Generates clock signals up to 125 MHz
- PLL guaranteed to lock down to 145 MHz, output frequency = 36.25 MHz
- Maximum output skew of 150 ps
- Differential LVPECL reference clock input
- External PLL feedback
- Drives up to 16 clock lines
- 32-lead LQFP packaging
- 32-lead Pb-free package available
- Ambient temperature range 0°C to +70°C
- Pin and function compatible to the MPC953 and MPC9653

Functional Description

The MPC9653A utilizes PLL technology to frequency lock its outputs onto an input reference clock. Normal operation of the MPC9653A requires the connection of the QFB output to the feedback input to close the PLL feedback path (external feedback). With the PLL locked, the output frequency is equal to the reference frequency of the device and VCO_SEL selects the operating frequency range of 25 to 62.5 MHz or 50 to 125 MHz. The two available post-PLL dividers selected by VCO_SEL (divide-by-4 or divide-by-8) and the reference clock frequency determine the VCO frequency. Both must be selected to match the VCO frequency range. The internal VCO of the MPC9653A is running at either 4x or 8x of the reference clock frequency. The MPC9653A is guaranteed to lock in a low power PLL mode in the high frequency range (VCO_SEL = 0) down to PLL = 145 MHz or $F_{ref} = 36.25$ MHz.

The MPC9653A has a differential LVPECL reference input along with an external feedback input. The device is ideal for use as a zero delay, low skew fanout buffer. The device performance has been tuned and optimized for zero delay performance.

The PLL_EN and \overline{BYPASS} controls select the PLL bypass configuration for test and diagnosis. In this configuration, the selected input reference clock is bypassing the PLL and routed either to the output dividers or directly to the outputs. The PLL bypass configurations are fully static and the minimum clock frequency specification and all other PLL characteristics do not apply. The outputs can be disabled (high-impedance) and the device reset by asserting the MR/OE pin. Asserting MR/OE also causes the PLL to loose lock due to missing feedback signal presence at FB_IN. Deasserting MR/OE will enable the outputs and close the phase locked loop, enabling the PLL to recover to normal operation.

The MPC9653A is fully 3.3 V compatible and requires no external loop filter components. The inputs (except PCLK) accept LVCMOS signals while the outputs provide LVCMOS compatible levels with the capability to drive terminated 50 Ω transmission lines. For series terminated transmission lines, each of the MPC9653A outputs can drive one or two traces giving the devices an effective fanout of 1:16. The device is packaged in a 7x7 mm² 32-lead LQFP package.

MPC9653A

**LOW VOLTAGE
3.3 V LVCMOS 1:8
PLL CLOCK GENERATOR**



FA SUFFIX
32 LEAD LQFP PACKAGE
CASE 873A



AC SUFFIX
32 LEAD LQFP PACKAGE-Pb-free
CASE 873A

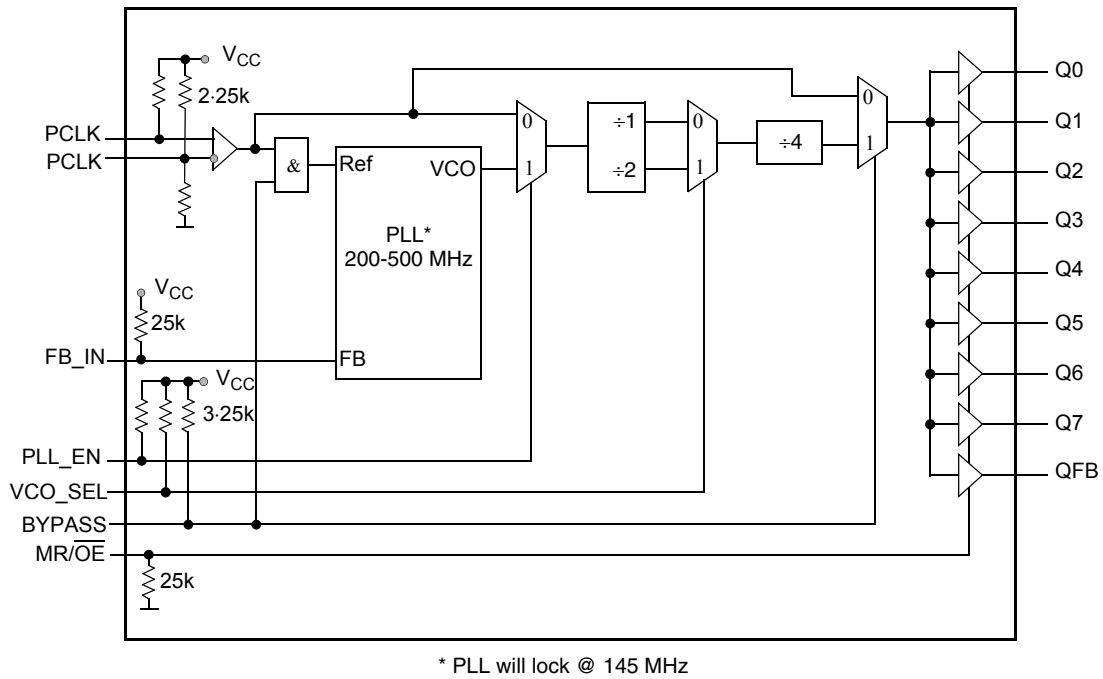

Figure 1. MPC9653A Logic Diagram

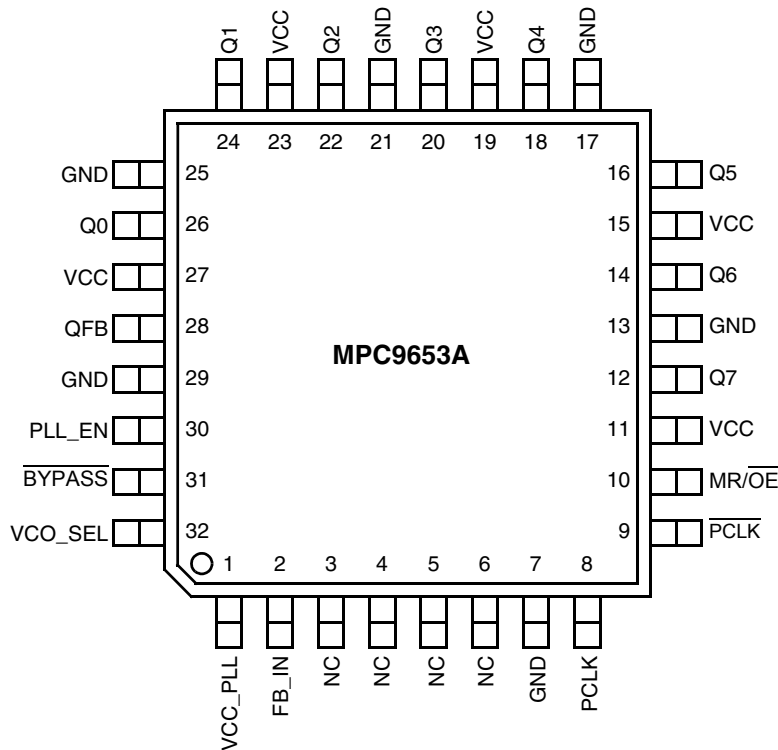

Figure 2. MPC9653A 32-Lead Package Pinout (Top View)

Table 1 . PIN CONFIGURATION

Pin	I/O	Type	Function
PCLK, PCLK	Input	LVPECL	PECL reference clock signal
FB_IN	Input	LVC MOS	PLL feedback signal input, connect to QFB
VCO_SEL	Input	LVC MOS	Operating frequency range select
BYPASS	Input	LVC MOS	PLL and output divider bypass select
PLL_EN	Input	LVC MOS	PLL enable/disable
MR/OE	Input	LVC MOS	Output enable/disable (high-impedance tristate) and device reset
Q0-7	Output	LVC MOS	Clock outputs
QFB	Output	LVC MOS	Clock output for PLL feedback, connect to FB_IN
GND	Supply	Ground	Negative power supply (GND)
VCC_PLL	Supply	VCC	PLL positive power supply (analog power supply). It is recommended to use an external RC filter for the analog power supply pin V _{CC_PLL} . Please see applications section for details.
VCC	Supply	VCC	Positive power supply for I/O and core. All VCC pins must be connected to the positive power supply for correct operation

Table 2. FUNCTION TABLE

Control	Default	0	1
PLL_EN	1	Test mode with PLL bypassed. The reference clock (PCLK) is substituted for the internal VCO output. MPC9653A is fully static and no minimum frequency limit applies. All PLL related AC characteristics are not applicable.	Selects the VCO output ^a
BYPASS	1	Test mode with PLL and output dividers bypassed. The reference clock (PCLK) is directly routed to the outputs. MPC9653A is fully static and no minimum frequency limit applies. All PLL related AC characteristics are not applicable.	Selects the output dividers.
VCO_SEL	1	VCO ÷ 1 (High frequency range). $f_{REF} = f_{Q0-7} = 4 \cdot f_{VCO}$	VCO ÷ 2 (Low output range). $f_{REF} = f_{Q0-7} = 8 \cdot f_{VCO}$
MR/OE	0	Outputs enabled (active)	Outputs disabled (high-impedance state) and reset of the device. During reset the PLL feedback loop is open. The VCO is tied to its lowest frequency. The length of the reset pulse should be greater than one reference clock cycle (PCLK).

a. PLL operation requires BYPASS = 1 and PLL_EN = 1.

Table 3. GENERAL SPECIFICATIONS

Symbol	Characteristics	Min	Typ	Max	Unit	Condition
V_{TT}	Output Termination Voltage		$V_{CC} \div 2$		V	
MM	ESD Protection (Machine Model)	200			V	
HBM	ESD Protection (Human Body Model)	2000			V	
LU	Latch-Up Immunity	200			mA	
C_{PD}	Power Dissipation Capacitance		10		pF	Per output
C_{IN}	Input Capacitance		4.0		pF	Inputs

Table 4. ABSOLUTE MAXIMUM RATINGS^a

Symbol	Characteristics	Min	Max	Unit	Condition
V_{CC}	Supply Voltage	-0.3	3.9	V	
V_{IN}	DC Input Voltage	-0.3	$V_{CC}+0.3$	V	
V_{OUT}	DC Output Voltage	-0.3	$V_{CC}+0.3$	V	
I_{IN}	DC Input Current		± 20	mA	
I_{OUT}	DC Output Current		± 50	mA	
T_S	Storage Temperature	-65	125	$^{\circ}\text{C}$	

- a. Absolute maximum continuous ratings are those maximum values beyond which damage to the device may occur. Exposure to these conditions or conditions beyond those indicated may adversely affect device reliability. Functional operation at absolute-maximum-rated conditions is not implied.

Table 5. DC CHARACTERISTICS ($V_{CC} = 3.3 \text{ V} \pm 5\%$, $T_A = 0^{\circ}\text{C}$ to 70°C)

Symbol	Characteristics	Min	Typ	Max	Unit	Condition
V_{IH}	Input high voltage	2.0		$V_{CC} + 0.3$	V	LVC MOS
V_{IL}	Input low voltage			0.8	V	LVC MOS
V_{PP}	Peak-to-peak input voltage(PCLK)	300			mV	LVPECL
V_{CMR}^a	Common Mode Range(PCLK)	1.0		$V_{CC}-0.6$	V	LVPECL
V_{OH}	Output High Voltage	2.4			V	$I_{OH} = -24 \text{ mA}^b$
V_{OL}	Output Low Voltage			0.55 0.30	V V	$I_{OL} = 24 \text{ mA}$ $I_{OL} = 12 \text{ mA}$
Z_{OUT}	Output impedance		14 - 17		Ω	
I_{IN}^c	Input Current			± 200	μA	$V_{IN} = V_{CC}$ or GND
I_{CC_PLL}	Maximum PLL Supply Current		5.0	10	mA	V_{CC_PLL} Pin
I_{CCQ}^d	Maximum Quiescent Supply Current			10	mA	All V_{CC} Pins

- a. V_{CMR} (DC) is the crosspoint of the differential input signal. Functional operation is obtained when the crosspoint is within the V_{CMR} range and the input swing lies within the V_{PP} (DC) specification.
- b. The MPC9653A is capable of driving 50Ω transmission lines on the incident edge. Each output drives one 50Ω parallel terminated transmission line to a termination voltage of V_{TT} . Alternatively, the device drives up to two 50Ω series terminated transmission lines. The MPC9653A meets the V_{OH} and V_{OL} specification of the MPC953 ($V_{OH} > V_{CC} - 0.6 \text{ V}$ at $I_{OH} = -20 \text{ mA}$ and $V_{OL} > 0.6 \text{ V}$ at $I_{OL} = 20 \text{ mA}$).
- c. Inputs have pull-down or pull-up resistors affecting the input current.
- d. $OE/\overline{MR} = 1$ (outputs in high-impedance state).

Table 6. AC CHARACTERISTICS ($V_{CC} = 3.3\text{ V} \pm 5\%$, $T_A = 0^\circ\text{C}$ to 70°C)^a

Symbol	Characteristics	Min	Typ	Max	Unit	Condition
f_{REF}	Input reference frequency $\div 4$ feedback ^b	50		125	MHz	PLL locked
	PLL mode, external feedback $\div 8$ feedback ^c	25		62.5	MHz	PLL locked
	Input reference frequency in PLL bypass mode ^d	0		200	MHz	
f_{VCO}	VCO operating frequency range ^{e,m}	200		500	MHz	
$f_{VCOlock}$	VCO lock frequency range ⁿ	145		500	MHz	
f_{MAX}	Output Frequency	$\div 4$ feedback ^b	50	125	MHz	PLL locked
		$\div 8$ feedback ^c	25	62.5	MHz	PLL locked
V_{PP}	Peak-to-peak input voltage			1000	mV	LVPECL
V_{CMRF}	Common Mode Range	1.2		$V_{CC}-0.75$	V	LVPECL
$t_{PW, MIN}$	Input Reference Pulse Width ^g	2			ns	
$t_{(\emptyset)}$	Propagation Delay (static phase offset) ^h	-75		125	ps	PLL locked
t_{PD}	Propagation Delay	PLL and divider bypass ($\overline{BYPASS} = 0$), PCLK to Q0-7	1.2	3.3	ns	
		PLL disable ($\overline{BYPASS} = 1$ and $PLL_EN = 0$), PCLK to Q0-7	3.0	7.0	ns	
$t_{sk(O)}$	Output-to-output Skew ^l			150	ps	
$t_{sk(PP)}$	Device-to-device Skew in PLL and divider bypass ^l			1.5	ns	$\overline{BYPASS} = 0$
DC	Output duty cycle	45	50	55	%	PLL locked
t_R, t_F	Output Rise/Fall Time	0.1		1.0	ns	0.55 to 2.4 V
$t_{PLZ, HZ}$	Output Disable Time			7.0	ns	
$t_{PZL, LZ}$	Output Enable Time			6.0	ns	
$t_{JIT(CC)}$	Cycle-to-cycle jitter			100	ps	
$t_{JIT(PER)}$	Period Jitter			100	ps	
$t_{JIT(\emptyset)}$	I/O Phase Jitter ^k			25	ps	RMS (1 σ)
BW	PLL closed loop bandwidth ^l	$\div 4$ feedback ^b		0.8 - 4	MHz	
		PLL mode, external feedback $\div 8$ feedback ^c		0.5 - 1.3	MHz	
t_{LOCK}	Maximum PLL Lock Time			10	ms	

- AC characteristics apply for parallel output termination of 50 Ω to V_{TT} .
- $\div 4$ PLL feedback (high frequency range) requires $VCO_SEL=0$, $PLL_EN=1$, $\overline{BYPASS} = 1$ and $MR/\overline{OE} = 0$.
- $\div 8$ PLL feedback (low frequency range) requires $VCO_SEL=1$, $PLL_EN=1$, $\overline{BYPASS} = 1$ and $MR/\overline{OE} = 0$.
- In bypass mode, the MPC9653A divides the input reference clock.
- The input frequency f_{REF} must match the VCO frequency range divided by the feedback divider ratio FB: $f_{REF} = f_{VCO} \div FB$.
- V_{CMR} (AC) is the crosspoint of the differential input signal. Normal AC operation is obtained when the crosspoint is within the V_{CMR} range and the input swing lies within the V_{PP} (AC) specification. Violation of V_{CMR} or V_{PP} impacts static phase offset $t_{(\emptyset)}$.
- Calculation of reference duty cycle limits: $DC_{REF,MIN} = t_{PW,MIN} \cdot f_{REF} \cdot 100\%$ and $DC_{REF,MAX} = 100\% - DC_{REF,MIN}$.
E.g. at $f_{REF} = 100$ MHz the input duty cycle range is $20\% < DC < 80\%$.
- Valid for $f_{REF} = 50$ MHz and $FB=\div 8$ ($VCO_SEL=1$). For other reference frequencies: $t_{(\emptyset)}$ [ps] = $50 \text{ ps} \pm (1 \div (120 \cdot f_{REF}))$.
- See application section for part-to-part skew calculation in PLL zero-delay mode.
- For a specified temperature and voltage, includes output skew.
- I/O phase jitter is reference frequency dependent. See application section for details.
- 3 dB point of PLL transfer characteristics.
- f_{VCO} is frequency range where AC parameters are guaranteed.
- $f_{VCOlock}$ is frequency range that the PLL guaranteed to lock, AC parameters only guaranteed over f_{VCO} .

APPLICATIONS INFORMATION

Programming the MPC9653A

The MPC9653A supports output clock frequencies from 25 to 125 MHz. Two different feedback divider configurations can be used to achieve the desired frequency operation range. The feedback divider (VCO_SEL) should be used to situate the VCO in the frequency lock range between 200 and 500 MHz for stable and optimal operation. Two operating frequency ranges

are supported: 25 to 62.5 MHz and 50 to 125 MHz. Table 9 illustrates the configurations supported by the MPC9653A. PLL zero-delay is supported if BYPASS=1, PLL_EN=1 and the input frequency is within the specified PLL reference frequency range.

Table 7. MPC9653A Configurations (QFB connected to FB_IN)

BYPASS	PLL_EN	VCO_SEL	Operation	Frequency		
				Ratio	Output range (f _{Q0-7})	VCO
0	X	X	Test mode: PLL and divider bypass	f _{Q0-7} = f _{REF}	0-200 MHz	n/a
1	0	0	Test mode: PLL bypass	f _{Q0-7} = f _{REF} ÷ 4	0-50 MHz	n/a
1	0	1	Test mode: PLL bypass	f _{Q0-7} = f _{REF} ÷ 8	0-25 MHz	n/a
1	1	0	PLL mode (high frequency range)	f _{Q0-7} = f _{REF}	50 to 125 MHz	f _{VCO} = f _{REF} · 4
1	1	1	PLL mode (low frequency range)	f _{Q0-7} = f _{REF}	25 to 62.5 MHz	f _{VCO} = f _{REF} · 8

Power Supply Filtering

The MPC9653A is a mixed analog/digital product. Its analog circuitry is naturally susceptible to random noise, especially if this noise is seen on the power supply pins. Random noise on the V_{CCA_PLL} power supply impacts the device characteristics, for instance I/O jitter. The MPC9653A provides separate power supplies for the output buffers (V_{CC}) and the phase-locked loop (V_{CCA_PLL}) of the device. The purpose of this design technique is to isolate the high switching noise digital outputs from the relatively sensitive internal analog phase-locked loop. In a digital system environment where it is more difficult to minimize noise on the power supplies a second level of isolation may be required. The simple but effective form of isolation is a power supply filter on the V_{CC_PLL} pin for the MPC9653A. Figure 3 illustrates a typical power supply filter scheme. The MPC9653A frequency and phase stability is most susceptible to noise with spectral content in the 100kHz to 20MHz range. Therefore the filter should be designed to target this range. The key parameter that needs to be met in the final filter design is the DC voltage drop across the series filter resistor R_F. From the data sheet the I_{CCA} current (the current sourced through the V_{CC_PLL} pin) is typically 5 mA (10 mA maximum), assuming that a minimum of 2.985V must be maintained on the V_{CC_PLL} pin.

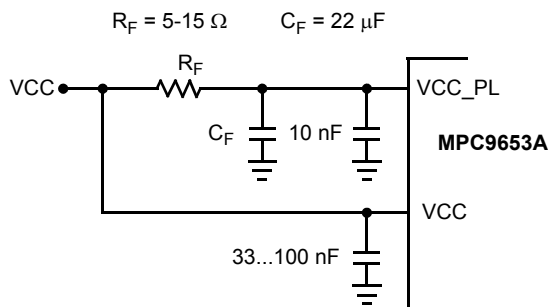

Figure 3. V_{CC_PLL} Power Supply Filter

The minimum values for R_F and the filter capacitor C_F are defined by the required filter characteristics: the RC filter should provide an attenuation greater than 40 dB for noise whose spectral content is above 100 kHz. In the example RC filter shown in Figure 3, “V_{CC_PLL} Power Supply Filter”, the filter cut-off frequency is around 4 kHz and the noise attenuation at 100 kHz is better than 42 dB.

As the noise frequency crosses the series resonant point of an individual capacitor its overall impedance begins to look inductive and thus increases with increasing frequency. The parallel capacitor combination shown ensures that a low impedance path to ground exists for frequencies well above the bandwidth of the PLL. Although the MPC9653A has several design features to minimize the susceptibility to power supply noise (isolated power and grounds and fully differential PLL) there still may be applications in which overall performance is being degraded due to system power supply noise. The power supply filter schemes discussed in this section should be adequate to eliminate power supply noise related problems in most designs.

Using the MPC9653A in zero-delay applications

Nested clock trees are typical applications for the MPC9653A. Designs using the MPC9653A as LVCMOS PLL fanout buffer with zero insertion delay will show significantly lower clock skew than clock distributions developed from CMOS fanout buffers. The external feedback option of the MPC9653A clock driver allows for its use as a zero delay buffer. The PLL aligns the feedback clock output edge with the clock input reference edge resulting a near zero delay through the device (the propagation delay through the device is virtually eliminated). The maximum insertion delay of the device in zero-delay applications is measured between the reference clock input and any output. This effective delay consists of the static phase offset, I/O jitter (phase or long-term jitter), feedback path delay and the output-to-output skew error relative to the feedback output.

Calculation of part-to-part skew

The MPC9653A zero delay buffer supports applications where critical clock signal timing can be maintained across several devices. If the reference clock inputs of two or more MPC9653A are connected together, the maximum overall timing uncertainty from the common PCLK input to any output is:

$$t_{SK(PP)} = t_{(\varnothing)} + t_{SK(O)} + t_{PD, LINE(FB)} + t_{JIT(\varnothing)} \cdot CF$$

This maximum timing uncertainty consist of 4 components: static phase offset, output skew, feedback board trace delay and I/O (phase) jitter:

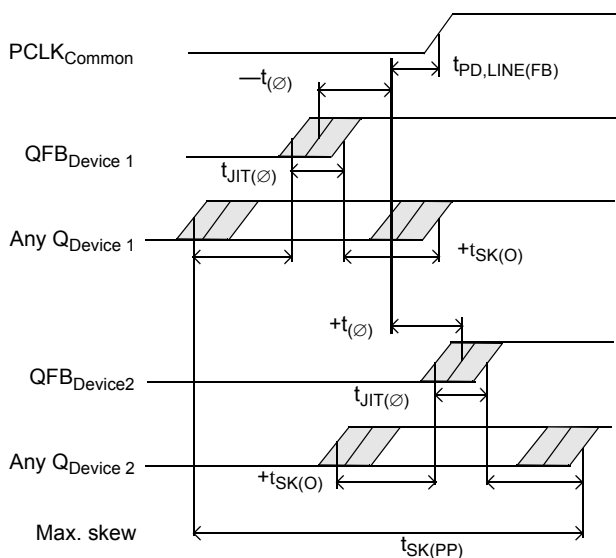

Figure 4. MPC9653A maximum device-to-device skew

Due to the statistical nature of I/O jitter a RMS value (1σ) is specified. I/O jitter numbers for other confidence factors (CF) can be derived from Table 10.

Table 8. Confidence Factor CF

CF	Probability of clock edge within the distribution
$\pm 1\sigma$	0.68268948
$\pm 2\sigma$	0.95449988
$\pm 3\sigma$	0.99730007
$\pm 4\sigma$	0.99993663
$\pm 5\sigma$	0.99999943
$\pm 6\sigma$	0.99999999

The feedback trace delay is determined by the board layout and can be used to fine-tune the effective delay through each device. In the following example calculation a I/O jitter confidence factor of 99.7% ($\pm 3\sigma$) is assumed, resulting in a worst

case timing uncertainty from input to any output of -197 ps to 297 ps (at 125 MHz reference frequency) relative to PCLK:

$$t_{SK(PP)} = [-17ps...117ps] + [-150ps...150ps] + [(10ps @ -3)...(10ps @ 3)] + t_{PD, LINE(FB)}$$

$$t_{SK(PP)} = [-197ps...297ps] + t_{PD, LINE(FB)}$$

Due to the frequency dependence of the I/O jitter, Figure 5, "Max. I/O Jitter versus frequency", can be used for a more precise timing performance analysis.

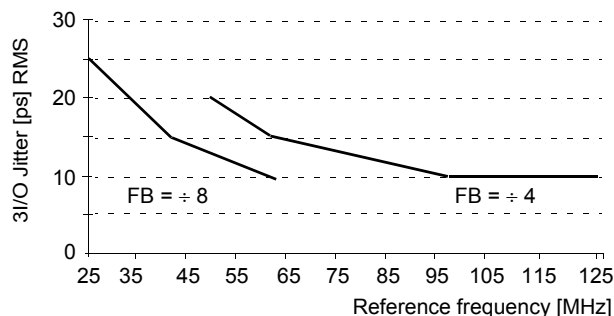

Figure 5. Maximum I/O Jitter versus frequency

Driving Transmission Lines

The MPC9653A clock driver was designed to drive high speed signals in a terminated transmission line environment. To provide the optimum flexibility to the user the output drivers were designed to exhibit the lowest impedance possible. With an output impedance of less than $20\ \Omega$ the drivers can drive either parallel or series terminated transmission lines. For more information on transmission lines the reader is referred to Motorola application note AN1091. In most high performance clock networks point-to-point distribution of signals is the method of choice. In a point-to-point scheme either series terminated or parallel terminated transmission lines can be used. The parallel technique terminates the signal at the end of the line with a $50\ \Omega$ resistance to $V_{CC} \div 2$.

This technique draws a fairly high level of DC current and thus only a single terminated line can be driven by each output of the MPC9653A clock driver. For the series terminated case however there is no DC current draw, thus the outputs can drive multiple series terminated lines. Figure 6, "Single versus Dual Transmission Lines", illustrates an output driving a single series terminated line versus two series terminated lines in parallel. When taken to its extreme the fanout of the MPC9653A clock driver is effectively doubled due to its capability to drive multiple lines.

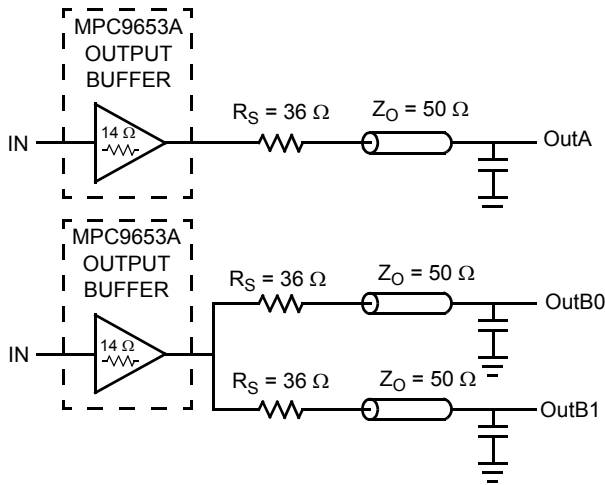

Figure 6. Single versus Dual Transmission Lines

The waveform plots in Figure 7, “Single versus Dual Line Termination Waveforms”, show the simulation results of an output driving a single line versus two lines. In both cases the drive capability of the MPC9653A output buffer is more than sufficient to drive 50 Ω transmission lines on the incident edge. Note from the delay measurements in the simulations a delta of only 43ps exists between the two differently loaded outputs. This suggests that the dual line driving need not be used exclusively to maintain the tight output-to-output skew of the MPC9653A. The output waveform in Figure 7 “Single versus Dual Line Termination Waveforms” shows a step in the waveform, this step is caused by the impedance mismatch seen looking into the driver. The parallel combination of the 36Ω series resistor plus the output impedance does not match the parallel combination of the line impedances. The voltage wave launched down the two lines will equal:

$$V_L = V_S (Z_0 \div (R_S + R_0 + Z_0))$$

$$Z_0 = 50 \Omega \parallel 50 \Omega$$

$$R_S = 36 \Omega \parallel 36 \Omega$$

$$R_0 = 14 \Omega$$

$$V_L = 3.0 (25 \div (18 + 14 + 25))$$

$$= 1.31 \text{ V}$$

At the load end the voltage will double, due to the near unity reflection coefficient, to 2.6 V. It will then increment towards the quiescent 3.0 V in steps separated by one round trip delay (in this case 4.0ns).

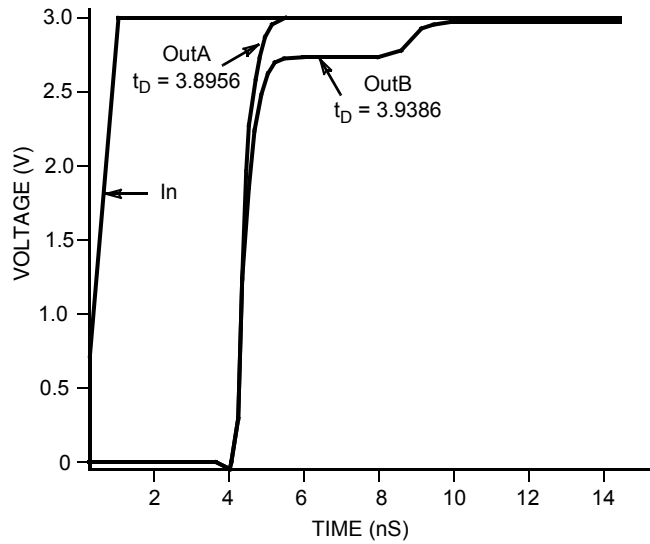

Figure 7. Single versus Dual Waveforms

Since this step is well above the threshold region it will not cause any false clock triggering, however designers may be uncomfortable with unwanted reflections on the line. To better match the impedances when driving multiple lines the situation in Figure 8, “Optimized Dual Line Termination”, should be used. In this case the series terminating resistors are reduced such that when the parallel combination is added to the output buffer impedance the line impedance is perfectly matched.

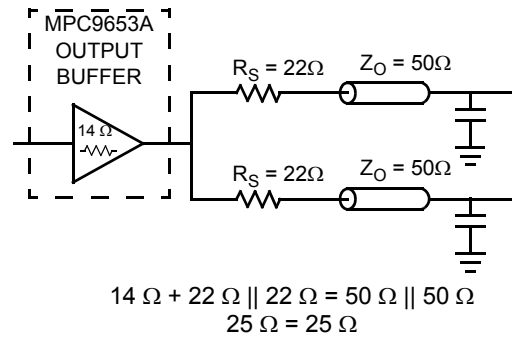

Figure 8. Optimized Dual Line Termination

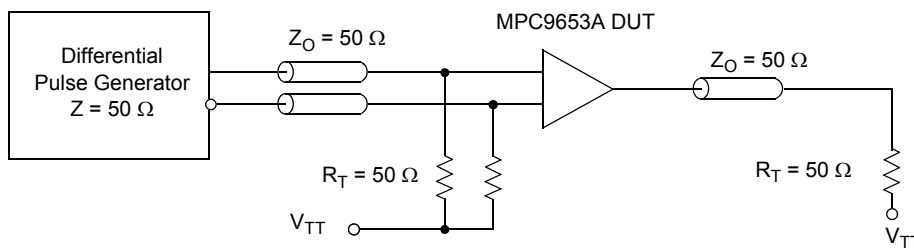
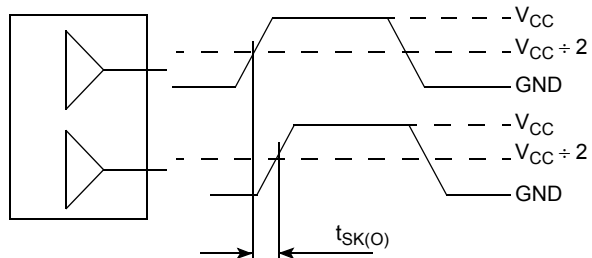

Figure 9. PCLK MPC9653A AC test reference



The pin-to-pin skew is defined as the worst case difference in propagation delay between any similar delay path within a single device

Figure 10. Output-to-output Skew $t_{SK(O)}$

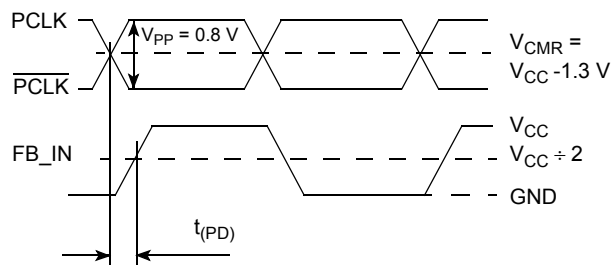
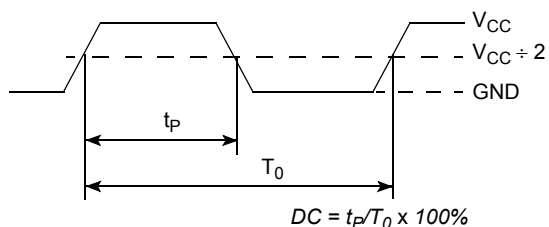
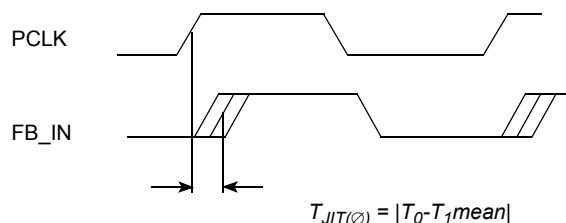

Figure 11. Propagation delay (t_{PD}), static phase offset) test reference



The time from the PLL controlled edge to the non controlled edge, divided by the time between PLL controlled edges, expressed as a percentage

Figure 12. Output Duty Cycle (DC)



The deviation in t_0 for a controlled edge with respect to a t_0 mean in a random sample of cycles

Figure 13. I/O Jitter

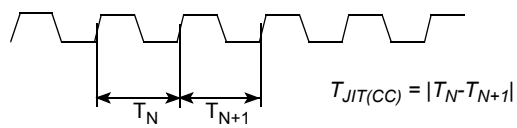

The variation in cycle time of a signal between adjacent cycles, over a random sample of adjacent cycle pairs

Figure 14. Cycle-to-cycle Jitter

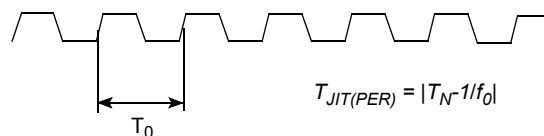

The deviation in cycle time of a signal with respect to the ideal period over a random sample of cycles

Figure 15. Period Jitter

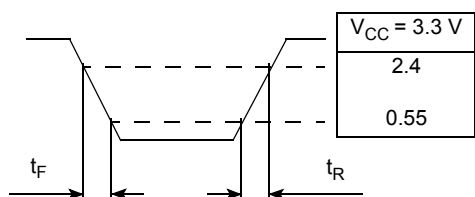
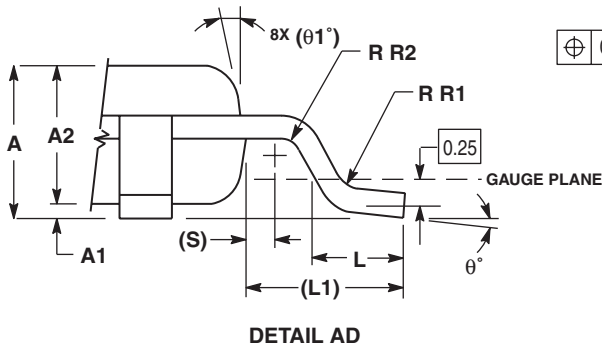
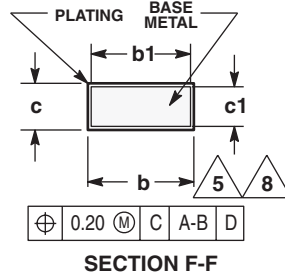
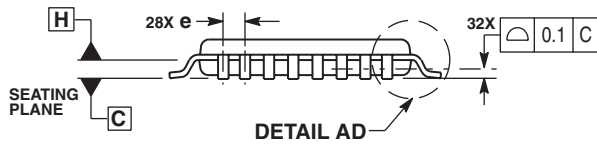
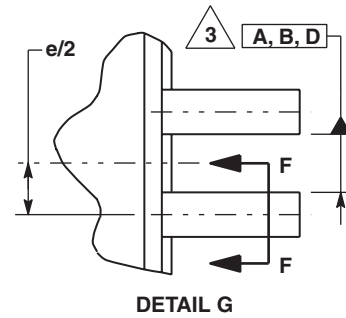
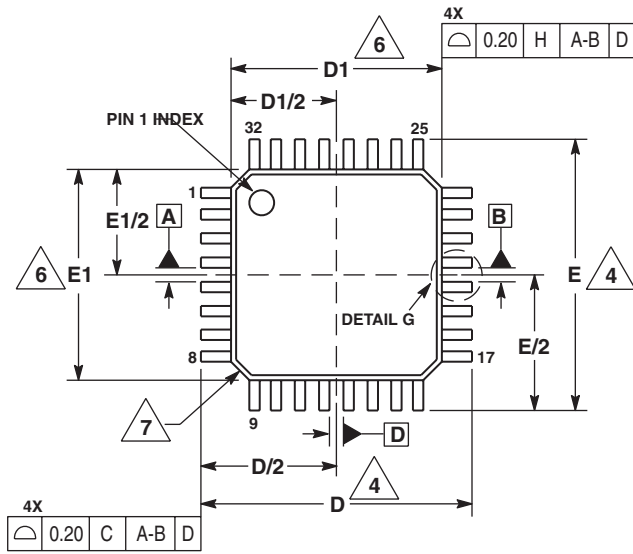

Figure 16. Output Transition Time Test Reference

OUTLINE DIMENSIONS



- NOTES:
1. DIMENSIONS ARE IN MILLIMETERS.
 2. INTERPRET DIMENSIONS AND TOLERANCES PER ASME Y14.5M, 1994.
 3. DATUMS A, B, AND D TO BE DETERMINED AT DATUM PLANE H.
 4. DIMENSIONS D AND E TO BE DETERMINED AT SEATING PLANE C.
 5. DIMENSION b DOES NOT INCLUDE DAMBAR PROTRUSION. ALLOWABLE DAMBAR PROTRUSION SHALL NOT CAUSE THE LEAD WIDTH TO EXCEED THE MAXIMUM b DIMENSION BY MORE THAN 0.08-mm. DAMBAR CANNOT BE LOCATED ON THE LOWER RADIUS OR THE FOOT. MINIMUM SPACE BETWEEN PROTRUSION AND ADJACENT LEAD OR PROTRUSION: 0.07-mm.
 6. DIMENSIONS D1 AND E1 DO NOT INCLUDE MOLD PROTRUSION. ALLOWABLE PROTRUSION IS 0.25-mm PER SIDE. D1 AND E1 ARE MAXIMUM PLASTIC BODY SIZE DIMENSIONS INCLUDING MOLD MISMATCH.
 7. EXACT SHAPE OF EACH CORNER IS OPTIONAL.
 8. THESE DIMENSIONS APPLY TO THE FLAT SECTION OF THE LEAD BETWEEN 0.1-mm AND 0.25-mm FROM THE LEAD TIP.

DIM	MILLIMETERS	
	MIN	MAX
A	1.40	1.60
A1	0.05	0.15
A2	1.35	1.45
b	0.30	0.45
b1	0.30	0.40
c	0.09	0.20
c1	0.09	0.16
D	9.00 BSC	
D1	7.00 BSC	
e	0.80 BSC	
E	9.00 BSC	
E1	7.00 BSC	
L	0.50	0.70
L1	1.00 REF	
q	0°	7°
q1	12 REF	
R1	0.08	0.20
R2	0.08	---
S	0.20 REF	

FA SUFFIX
LQFP PACKAGE
AC SUFFIX
LQFP PACKAGE-Pb-free
CASE 873A-03
ISSUE B

NOTES

Information in this document is provided solely to enable system and software implementers to use Motorola products. There are no express or implied copyright licenses granted hereunder to design or fabricate any integrated circuits or integrated circuits based on the information in this document.

Motorola reserves the right to make changes without further notice to any products herein. Motorola makes no warranty, representation or guarantee regarding the suitability of its products for any particular purpose, nor does Motorola assume any liability arising out of the application or use of any product or circuit, and specifically disclaims any and all liability, including without limitation consequential or incidental damages. "Typical" parameters which may be provided in Motorola data sheets and/or specifications can and do vary in different applications and actual performance may vary over time. All operating parameters, including "Typicals" must be validated for each customer application by customer's technical experts. Motorola does not convey any license under its patent rights nor the rights of others. Motorola products are not designed, intended, or authorized for use as components in systems intended for surgical implant into the body, or other applications intended to support or sustain life, or for any other application in which the failure of the Motorola product could create a situation where personal injury or death may occur. Should Buyer purchase or use Motorola products for any such unintended or unauthorized application, Buyer shall indemnify and hold Motorola and its officers, employees, subsidiaries, affiliates, and distributors harmless against all claims, costs, damages, and expenses, and reasonable attorney fees arising out of, directly or indirectly, any claim of personal injury or death associated with such unintended or unauthorized use, even if such claim alleges that Motorola was negligent regarding the design or manufacture of the part.

MOTOROLA and the Stylized M Logo are registered in the US Patent and Trademark Office. All other product or service names are the property of their respective owners.

© Motorola, Inc. 2004

HOW TO REACH US:

USA/EUROPE/LOCATIONS NOT LISTED:
Motorola Literature Distribution
P.O. Box 5405, Denver, Colorado 80217
1-800-521-6274 or 480-768-2130

JAPAN: Motorola Japan Ltd.; SPS, Technical Information Center
3-20-1 Minami-Azabu, Minato-ku, Tokyo 106-8573, Japan
81-3-3440-3569

ASIA/PACIFIC: Motorola Semiconductors H.K. Ltd.; Silicon Harbour Centre
2 Dai King Street, Tai Po Industrial Estate, Tai Po, N.T., Hong Kong
852-26668334

HOME PAGE: <http://motorola.com/semiconductors>

