

DO NOT
SCALE FROM
THIS PRINT

DESIGNED & DIMENSIONED
IN INCHES[MILLIMETERS]

PRF18-P-C-EE-405-SD

SERIES
-18: 1.85mm

GENDER
-P: PLUG

TYPE
-C: CABLE

FINISH
-EE: 50μ" EXTRA HEAVY GOLD
CENTER CONTACT, 50μ" EXTRA
HEAVY GOLD OUTER CONTACT

TERMINATION
-D: DIRECT SOLDER

ORIENTATION
-S: STRAIGHT

CABLE TYPE
-405: RG-405

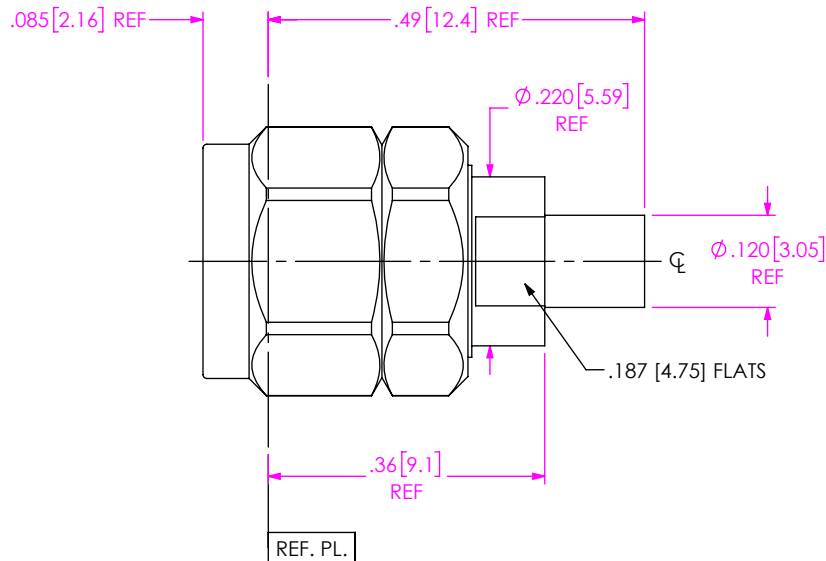
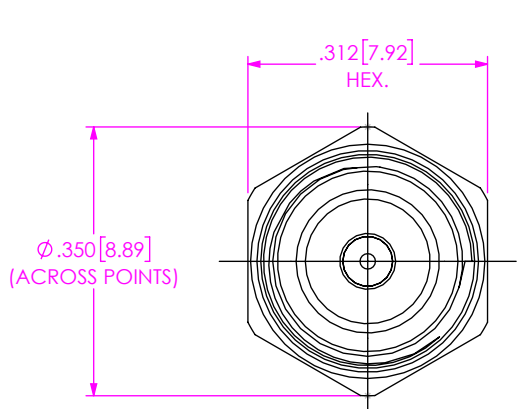

NOTES:

- MATERIAL:
COUPLING NUT & BUSHING: STAINLESS STEEL.
BODY, CONTACT & LOCK RING: BERYLLIUM COPPER.
BEAD: ULTEM 1000.
GASKET: SILICONE RUBBER.
- FINISH:
COUPLING NUT & BUSHING: PASSIVATED.
BODY & CONTACT: GOLD OVER NICKEL PLATE,
50 MIN GOLD OVER 50 MIN NICKEL.
- PCI P/N: 4119.

c:\enterprisevault\DWG\MISC\MKTG\PRF18-P-C-EE-405-SD-MKT.SLDDRW

UNLESS OTHERWISE SPECIFIED, DIMENSIONS ARE IN INCHES. TOLERANCES ARE: DECIMALS ANGLES .XX: ±.02[0.5] 1° .XXX: ±.005[0.13] .XXXX: ±.0005[0.013]	* PROPRIETARY NOTE * THIS DOCUMENT CONTAINS CONFIDENTIAL AND PROPRIETARY INFORMATION AND ALL DESIGN, MANUFACTURING, REPRODUCTION, USE, PATENT RIGHTS AND SALES RIGHTS ARE EXPRESSLY RESERVED BY SAMTEC, INC. THIS DOCUMENT SHALL NOT BE DISCLOSED, IN WHOLE OR PART, TO ANY UNAUTHORIZED PERSON OR ENTITY NOR REPRODUCED, TRANSFERRED OR INCORPORATED IN ANY OTHER PROJECT IN ANY MANNER WITHOUT THE EXPRESS WRITTEN CONSENT OF SAMTEC, INC.	 520 PARK EAST BLVD, NEW ALBANY, IN 47150 PHONE: 812-944-6733 FAX: 812-948-5047 e-Mail: info@SAMTEC.com code 55322
		DESCRIPTION: 1.85MM PLUG, DIRECT SOLDER FOR RG-405 CABLE DWG. NO. PRF18-P-C-EE-405-SD BY: ETHAN C 03/04/2021 SHEET 1 OF 2

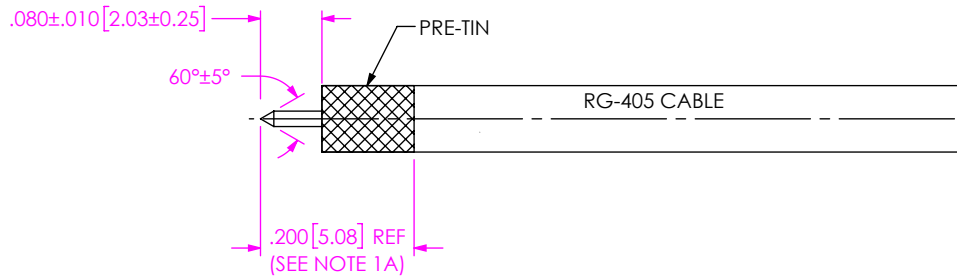

- 1A. PRE-TIN CABLE OUTER JACKET OVER APPROX. LENGTH SHOWN.
- 1B. TRIM CABLE TO EXPOSE CENTER CONDUCTOR AS SHOWN.
- 1C. POINT CENTER CONDUCTOR AS INDICATED.

IN-PROCESS 1

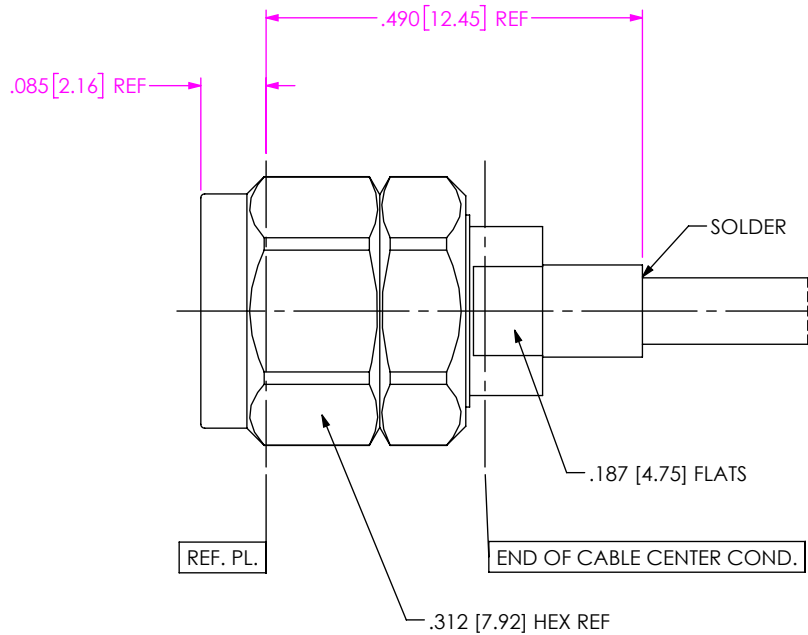

- 2A. INSERT CABLE INTO CONNECTOR UNTIL CENTER CONDUCTOR PLUGS IN AND CABLE SEATS IN CONNECTOR BORE.
- 2B. SOLDER CABLE JACKET TO BODY WHERE SHOWN APPLYING HEAT TO EXTENDED BODY TAIL.

IN-PROCESS 2

<p>DO NOT SCALE DRAWING</p> <p>SHEET SCALE: 4:1</p>	<p>PROPRIETARY NOTE</p> <p>THIS DOCUMENT CONTAINS CONFIDENTIAL AND PROPRIETARY INFORMATION AND ALL DESIGN, MANUFACTURING, REPRODUCTION, USE, PATENT RIGHTS AND SALES RIGHTS ARE EXPRESSLY RESERVED BY SAMTEC, INC. THIS DOCUMENT SHALL NOT BE DISCLOSED, IN WHOLE OR PART, TO ANY UNAUTHORIZED PERSON OR ENTITY NOR REPRODUCED, TRANSFERRED OR INCORPORATED IN ANY OTHER PROJECT IN ANY MANNER WITHOUT THE EXPRESS WRITTEN CONSENT OF SAMTEC, INC.</p>	
	 <p>520 PARK EAST BLVD, NEW ALBANY, IN 47150 PHONE: 812-944-6733 FAX: 812-948-5047 e-Mail info@SAMTEC.com code 55322</p>	
	<p>DESCRIPTION: 1.85MM PLUG, DIRECT SOLDER FOR RG-405 CABLE</p> <p>DWG. NO. PRF18-P-C-EE-405-SD</p>	<p>BY: ETHAN C 03/04/2021</p>