

TQFP  
Commercial Temp  
Industrial Temp

**64K x 32**  
**2Mb Synchronous Burst SRAM**

**180 MHz–66 MHz**  
**3.3 V V<sub>DD</sub>**  
**3.3 V and 2.5 V I/O**

### Features

- $\overline{FT}$  pin for user-configurable flow through or pipelined operation
- Single Cycle Deselect (SCD) operation
- 3.3 V +10%/–5% core power supply
- 2.5 V or 3.3 V I/O supply
- $\overline{LBO}$  pin for Linear or Interleaved Burst mode
- Internal input resistors on mode pins allow floating mode pins
- Default to Interleaved Pipelined mode
- Byte Write ( $\overline{BW}$ ) and/or Global Write ( $\overline{GW}$ ) operation
- Common data inputs and data outputs
- Clock Control, registered, address, data, and control
- Internal self-timed write cycle
- Automatic power-down for portable applications
- JEDEC standard 100-lead TQFP package
- RoHS-compliant 100-lead TQFP package available

### Functional Description

#### Applications

The GS82032A is a 2,097,152-bit high performance synchronous SRAM with a 2-bit burst address counter. Although of a type originally developed for Level 2 Cache applications supporting high performance CPUs, the device now finds application in synchronous SRAM applications, ranging from DSP main store to networking chip set support.

#### Controls

Addresses, data I/Os, chip enables ( $\overline{E1}$ ,  $\overline{E2}$ ,  $\overline{E3}$ ), address burst control inputs ( $\overline{ADSP}$ ,  $\overline{ADSC}$ ,  $\overline{ADV}$ ), and write control inputs ( $\overline{Bx}$ ,  $\overline{BW}$ ,  $\overline{GW}$ ) are synchronous and are controlled by a positive-edge-triggered clock input (CK). Output enable ( $\overline{G}$ ) and power down control (ZZ) are asynchronous inputs. Burst cycles can be initiated with either  $\overline{ADSP}$  or  $\overline{ADSC}$  inputs. In Burst mode, subsequent burst addresses are generated internally and are controlled by  $\overline{ADV}$ . The burst address

counter may be configured to count in either linear or interleave order with the Linear Burst Order ( $\overline{LBO}$ ) input. The Burst function need not be used. New addresses can be loaded on every cycle with no degradation of chip performance.

#### Flow Through/Pipeline Reads

The function of the Data Output Register can be controlled by the user via the  $\overline{FT}$  mode pin (Pin 14 in the TQFP). Holding the  $\overline{FT}$  mode pin low places the RAM in Flow Through mode, causing output data to bypass the Data Output Register. Holding  $\overline{FT}$  high places the RAM in Pipelined mode, activating the rising-edge-triggered Data Output Register.

#### SCD Pipelined Reads

The GS82032A is an SCD (Single Cycle Deselect) pipelined synchronous SRAM. DCD (Dual Cycle Deselect) versions are also available. SCD SRAMs pipeline deselect commands one stage less than read commands. SCD RAMs begin turning off their outputs immediately after the deselect command has been captured in the input registers.

#### Byte Write and Global Write

Byte write operation is performed by using Byte Write enable ( $\overline{BW}$ ) input combined with one or more individual byte write signals ( $\overline{Bx}$ ). In addition, Global Write ( $\overline{GW}$ ) is available for writing all bytes at one time, regardless of the Byte Write control inputs.

#### Sleep Mode

Low power (Sleep mode) is attained through the assertion (High) of the ZZ signal, or by stopping the clock (CK). Memory data is retained during Sleep mode.

#### Core and Interface Voltages

The GS82032A operates on a 3.3 V power supply and all inputs/outputs are 3.3 V- and 2.5 V-compatible. Separate output power (V<sub>DDQ</sub>) pins are used to decouple output noise from the internal circuit.

### Parameter Synopsis

		-180	-166	-150	-133 (-4)	-100 (-5)	-66 (-6)
Pipeline	tCycle	5.5 ns	6 ns	6.6 ns	7.5 ns	10 ns	12.5 ns
	3-1-1-1						
	tkQ	3.2 ns	3.5 ns	3.8 ns	4 ns	5 ns	6 ns
	I <sub>DD</sub>	155 mA	140 mA	130 mA	115 mA	90 mA	65 mA
Flow Through	tCycle	9.1 ns	10 ns	10.5 ns	12 ns	15 ns	20 ns
	2-1-1-1						
	tkQ	8 ns	8.5 ns	9 ns	10 ns	12 ns	18 ns
	I <sub>DD</sub>	100 mA	90 mA	85 mA	80 mA	65 mA	50 mA

GS82032A 100-Pin TQFP Pinout

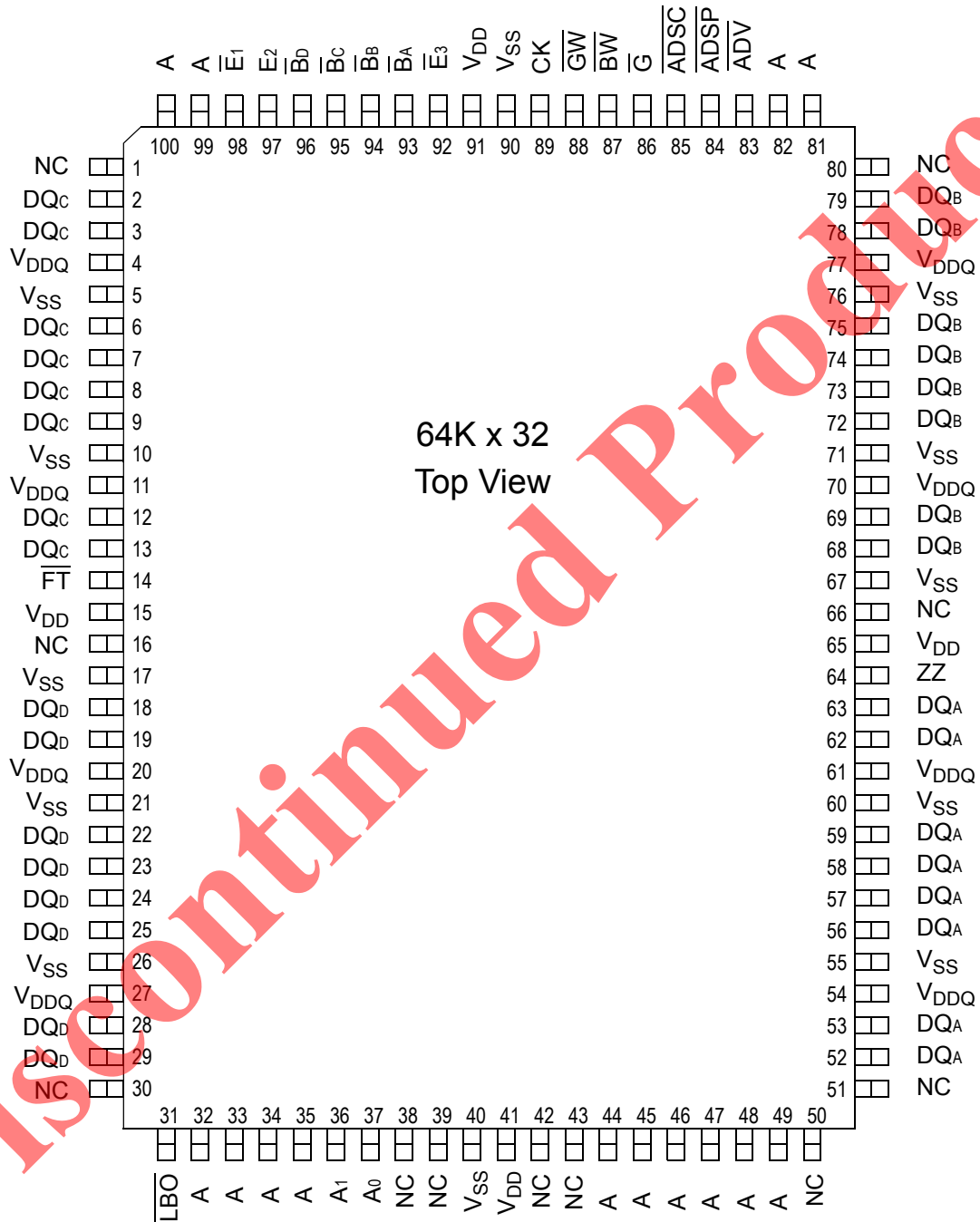

**TQFP Pin Description**

Symbol	Type	Description
A <sub>0</sub> , A <sub>1</sub>	I	Address field LSBs and Address Counter preset Inputs
A	I	Address Inputs
DQ <sub>A</sub> DQ <sub>B</sub> DQ <sub>C</sub> DQ <sub>D</sub>	I/O	Data Input and Output pins
NC		No Connect
$\overline{BW}$	I	Byte Write—Writes all enabled bytes; active low
$\overline{BA}$ , $\overline{BB}$	I	Byte Write Enable for DQ <sub>A</sub> , DQ <sub>B</sub> Data I/Os; active low
$\overline{BC}$ , $\overline{BD}$	I	Byte Write Enable for DQ <sub>C</sub> , DQ <sub>D</sub> Data I/Os; active low
CK	I	Clock Input Signal; active high
$\overline{GW}$	I	Global Write Enable—Writes all bytes; active low
$\overline{E1}$ , $\overline{E3}$	I	Chip Enable; active low
E <sub>2</sub>	I	Chip Enable; active high
$\overline{G}$	I	Output Enable; active low
$\overline{ADV}$	I	Burst address counter advance enable; active low
$\overline{ADSP}$ , $\overline{ADSC}$	I	Address Strobe (Processor, Cache Controller); active low
ZZ	I	Sleep Mode control; active high
$\overline{FT}$	I	Flow Through or Pipeline mode; active low
$\overline{LBO}$	I	Linear Burst Order mode; active low
V <sub>DD</sub>	I	Core power supply
V <sub>SS</sub>	I	I/O and Core Ground
V <sub>DDQ</sub>	I	Output driver power supply

GS82032A Block Diagram

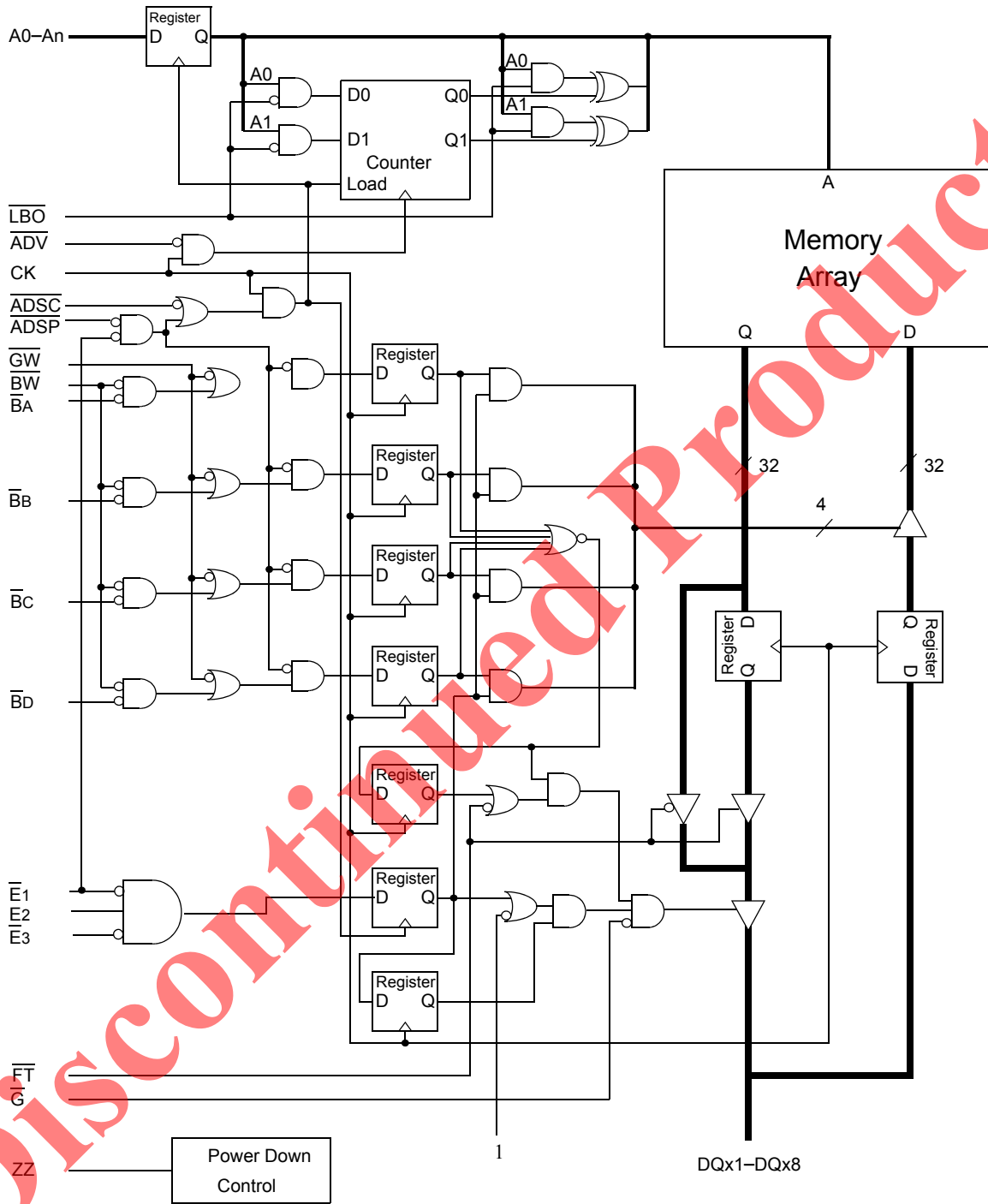

Discontinued Product

## Mode Pin Functions

Mode Name	Pin Name	State	Function
Burst Order Control	$\overline{\text{LBO}}$	L	Linear Burst
		H or NC	Interleaved Burst
Output Register Control	$\overline{\text{FT}}$	L	Flow Through
		H or NC	Pipeline
Power Down Control	ZZ	L or NC	Active
		H	Standby, $I_{DD} = I_{SB}$

### Note:

There are pull-up devices on  $\overline{\text{LBO}}$  and  $\overline{\text{FT}}$  pins and a pull-down device on the ZZ pin, so those input pins can be unconnected and the chip will operate in the default states as specified in the above table.

## Burst Counter Sequences

### Linear Burst Sequence

	A[1:0]	A[1:0]	A[1:0]	A[1:0]
1st address	00	01	10	11
2nd address	01	10	11	00
3rd address	10	11	00	01
4th address	11	00	01	10

### Note:

The burst counter wraps to initial state on the 5th clock.

### Interleaved Burst Sequence

	A[1:0]	A[1:0]	A[1:0]	A[1:0]
1st address	00	01	10	11
2nd address	01	00	11	10
3rd address	10	11	00	01
4th address	11	10	01	00

### Note:

The burst counter wraps to initial state on the 5th clock.

**Byte Write Truth Table**

Function	$\overline{GW}$	$\overline{BW}$	$\overline{B_A}$	$\overline{B_B}$	$\overline{B_C}$	$\overline{B_D}$	Notes
Read	H	H	X	X	X	X	1
Read	H	L	H	H	H	H	1
Write byte A	H	L	L	H	H	H	2, 3
Write byte B	H	L	H	L	H	H	2, 3
Write byte C	H	L	H	H	L	H	2, 3, 4
Write byte D	H	L	H	H	H	L	2, 3, 4
Write all bytes	H	L	L	L	L	L	2, 3, 4
Write all bytes	L	X	X	X	X	X	

**Notes:**

1. All byte outputs are active in read cycles regardless of the state of Byte Write Enable inputs.
2. Byte Write Enable inputs  $\overline{B_A}$ ,  $\overline{B_B}$ ,  $\overline{B_C}$  and/or  $\overline{B_D}$  may be used in any combination with  $\overline{BW}$  to write single or multiple bytes.
3. All byte I/Os remain High-Z during all write operations regardless of the state of Byte Write Enable inputs.

**Synchronous Truth Table**

Operation	Address Used	State Diagram Key <sup>5</sup>	$\bar{E}_1$	$E^2$	$\overline{ADSP}$	$\overline{ADSC}$	$\overline{ADV}$	$W^3$	$DQ^4$
<b>Deselect Cycle, Power Down</b>	<b>None</b>	<b>X</b>	<b>H</b>	<b>X</b>	<b>X</b>	<b>L</b>	<b>X</b>	<b>X</b>	<b>High-Z</b>
Deselect Cycle, Power Down	None	X	L	F	L	X	X	X	High-Z
<b>Deselect Cycle, Power Down</b>	<b>None</b>	<b>X</b>	<b>L</b>	<b>F</b>	<b>H</b>	<b>L</b>	<b>X</b>	<b>X</b>	<b>High-Z</b>
Read Cycle, Begin Burst	External	R	L	T	L	X	X	X	Q
<b>Read Cycle, Begin Burst</b>	<b>External</b>	<b>R</b>	<b>L</b>	<b>T</b>	<b>H</b>	<b>L</b>	<b>X</b>	<b>F</b>	<b>Q</b>
<b>Write Cycle, Begin Burst</b>	<b>External</b>	<b>W</b>	<b>L</b>	<b>T</b>	<b>H</b>	<b>L</b>	<b>X</b>	<b>T</b>	<b>D</b>
<i>Read Cycle, Continue Burst</i>	<i>Next</i>	<i>CR</i>	<i>X</i>	<i>X</i>	<i>H</i>	<i>H</i>	<i>L</i>	<i>F</i>	<i>Q</i>
Read Cycle, Continue Burst	Next	CR	H	X	X	H	L	F	Q
<i>Write Cycle, Continue Burst</i>	<i>Next</i>	<i>CW</i>	<i>X</i>	<i>X</i>	<i>H</i>	<i>H</i>	<i>L</i>	<i>T</i>	<i>D</i>
Write Cycle, Continue Burst	Next	CW	H	X	X	H	L	T	D
Read Cycle, Suspend Burst	Current		X	X	H	H	H	F	Q
Read Cycle, Suspend Burst	Current		H	X	X	H	H	F	Q
Write Cycle, Suspend Burst	Current		X	X	H	H	H	T	D
Write Cycle, Suspend Burst	Current		H	X	X	H	H	T	D

**Notes:**

1. X = Don't Care, H = High, L = Low
2. E = T (True) if  $E_2 = 1$  and  $\bar{E}_3 = 0$ ; E = F (False) if  $E_2 = 0$  or  $\bar{E}_3 = 1$
3.  $\bar{W}$  = T (True) and F (False) is defined in the Byte Write Truth Table preceding
4.  $\bar{G}$  is an asynchronous input.  $\bar{G}$  can be driven high at any time to disable active output drivers.  $\bar{G}$  low can only enable active drivers (shown as "Q" in the Truth Table above).
5. All input combinations shown above are tested and supported. Input combinations shown in gray boxes need not be used to accomplish basic synchronous or synchronous burst operations and may be avoided for simplicity.
6. Tying  $\overline{ADSP}$  high and  $\overline{ADSC}$  low allows simple non-burst synchronous operations. See **BOLD** items above.
7. Tying  $\overline{ADSP}$  high and  $\overline{ADV}$  low while using  $\overline{ADSC}$  to load new addresses allows simple burst operations. See *ITALIC* items above.

## Simplified State Diagram

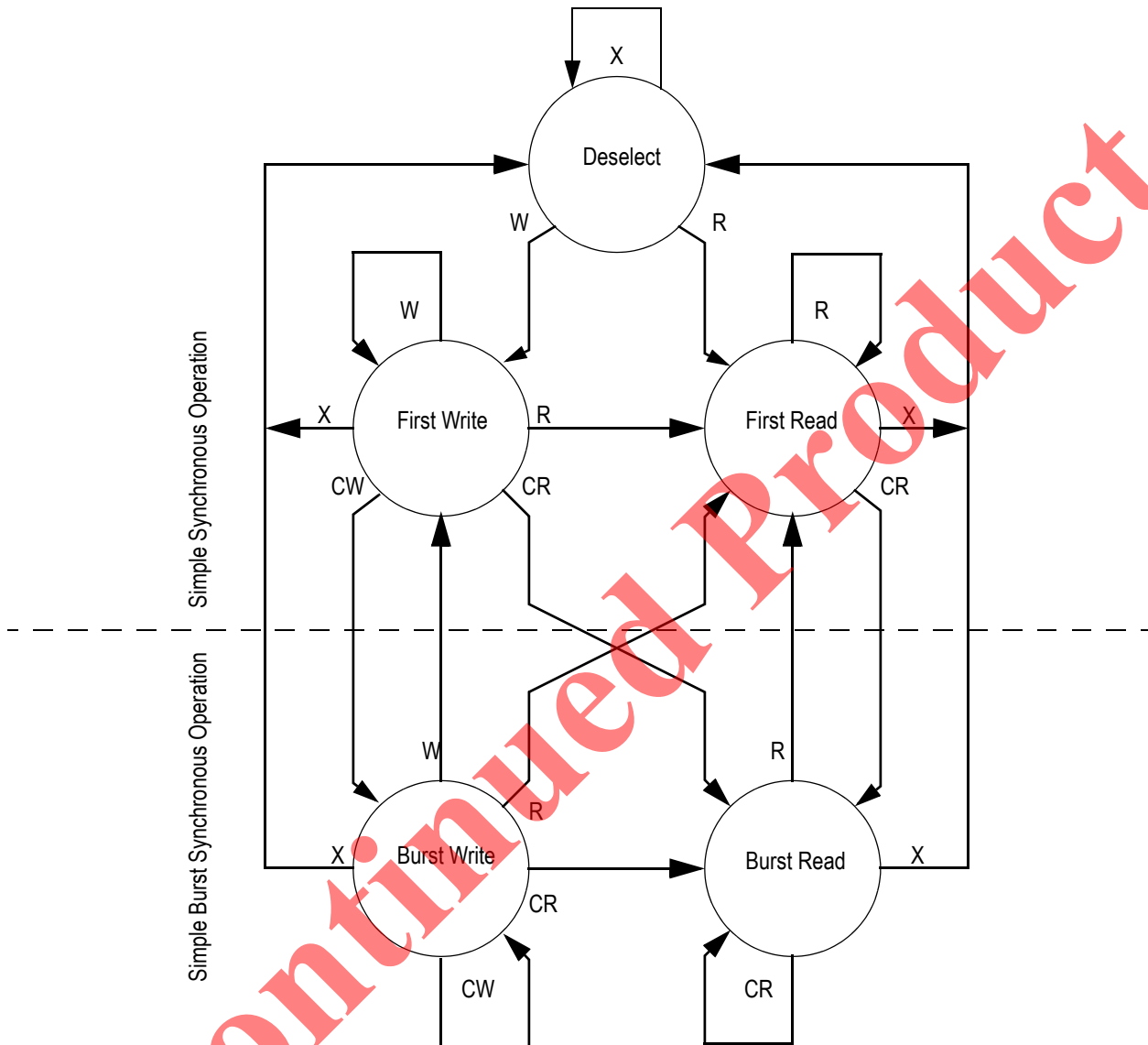
**Notes:**

1. The diagram shows only supported (tested) synchronous state transitions. The diagram presumes  $\overline{G}$  is tied low.
2. The upper portion of the diagram assumes active use of only the Enable ( $\overline{E}_1, \overline{E}_2, \overline{E}_3$ ) and Write ( $\overline{B}_A, \overline{B}_B, \overline{B}_C, \overline{B}_D, \overline{B}_W$ , and  $\overline{G}_W$ ) control inputs, and that ADSP is tied high and ADSC is tied low.
3. The upper and lower portions of the diagram together assume active use of only the Enable, Write, and  $\overline{ADSC}$  control inputs, and assumes ADSP is tied high and ADV is tied low.

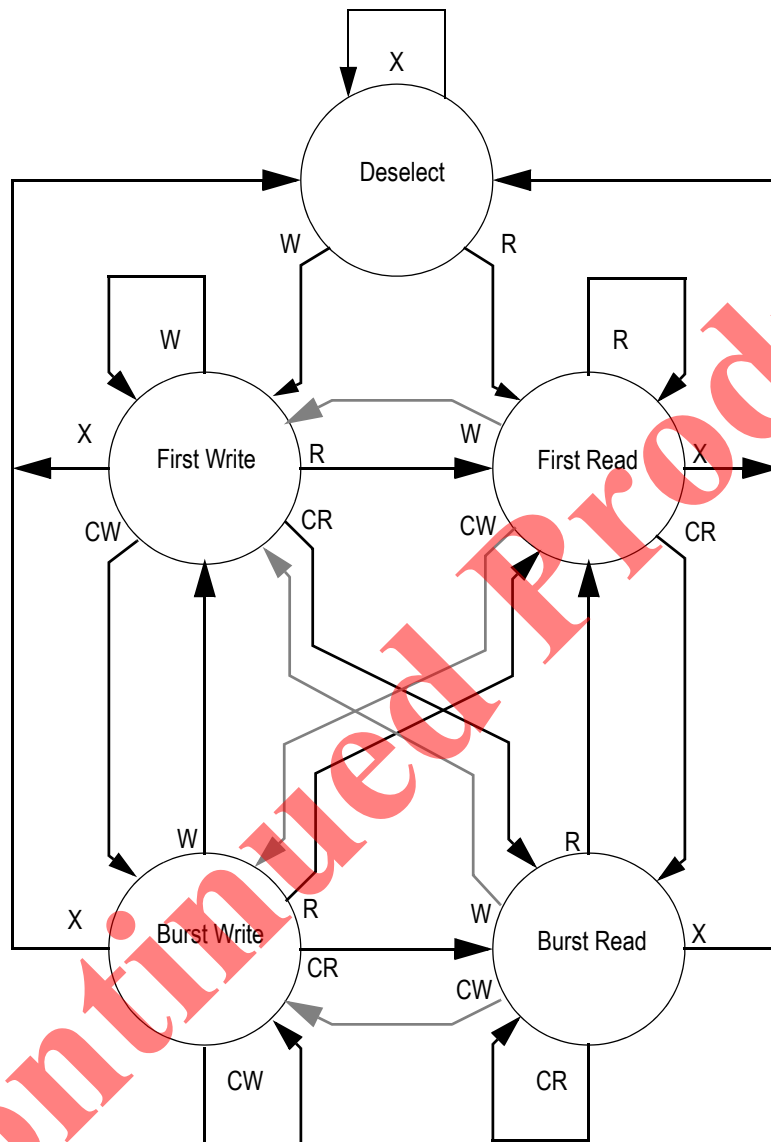
Simplified State Diagram with  $\bar{G}$ 

**Notes:**

1. The diagram shows supported (tested) synchronous state transitions, plus supported transitions that depend upon the use of  $\bar{G}$ .
2. Use of "Dummy Reads" (Read Cycles with  $\bar{G}$  high) may be used to make the transition from Read cycles to Write cycles without passing through a Deselect cycle. Dummy Read cycles increment the address counter just like normal Read cycles.
3. Transitions shown in gray assume  $\bar{G}$  has been pulsed high long enough to turn the RAM's drivers off and for incoming data to meet Data Input Set Up Time.

**Absolute Maximum Ratings**

 (All voltages reference to  $V_{SS}$ )

Symbol	Description	Value	Unit
$V_{DD}$	Voltage on $V_{DD}$ Pins	-0.5 to 4.6	V
$V_{DDQ}$	Voltage in $V_{DDQ}$ Pins	-0.5 to $V_{DD}$	V
$V_{CK}$	Voltage on Clock Input Pin	-0.5 to 6	V
$V_{I/O}$	Voltage on I/O Pins	-0.5 to $V_{DDQ}+0.5$ ( $\leq 4.6$ V max.)	V
$V_{IN}$	Voltage on Other Input Pins	-0.5 to $V_{DD}+0.5$ ( $\leq 4.6$ V max.)	V
$I_{IN}$	Input Current on Any Pin	+/-20	mA
$I_{OUT}$	Output Current on Any I/O Pin	+/-20	mA
$P_D$	Package Power Dissipation	1.5	W
$T_{STG}$	Storage Temperature	-55 to 125	°C
$T_{BIAS}$	Temperature Under Bias	-55 to 125	°C

**Note:**

Permanent damage to the device may occur if the Absolute Maximum Ratings are exceeded. Operation should be restricted to Recommended Operating Conditions. Exposure to conditions exceeding the Absolute Maximum Ratings, for an extended period of time, may affect reliability of this component.

**Recommended Operating Conditions**

Parameter	Symbol	Min.	Typ.	Max.	Unit	Notes
Supply Voltage	$V_{DD}$	3.135	3.3	3.6	V	1
I/O Supply Voltage	$V_{DDQ}$	2.375	2.5	$V_{DD}$	V	1
Input High Voltage	$V_{IH}$	1.7	—	$V_{DD}+0.3$	V	2
Input Low Voltage	$V_{IL}$	-0.3	—	0.8	V	2
Ambient Temperature (Commercial Range Versions)	$T_A$	0	25	70	°C	3
Ambient Temperature (Industrial Range Versions)	$T_A$	-40	25	85	°C	3

**Notes:**

- Unless otherwise noted, all performance specifications quoted are evaluated for worst case at both  $2.75\text{ V} \leq V_{DDQ} \leq 2.375\text{ V}$  (i.e., 2.5 V I/O) and  $3.6\text{ V} \leq V_{DD} \leq 3.135\text{ V}$  (i.e., 3.3 V I/O) and quoted at whichever condition is worst case.
- This device features input buffers compatible with both 3.3 V and 2.5 V I/O drivers.
- Most speed grades and configurations of this device are offered in both Commercial and Industrial Temperature ranges. The part number of Industrial Temperature Range versions end with the character "I". Unless otherwise noted, all performance specifications quoted are evaluated for worst case in the temperature range marked on the device.
- Input Under/overshoot voltage must be  $-2\text{ V} > V_i < V_{DD}+2\text{ V}$  with a pulse width not to exceed 20% tKC.

### Undershoot Measurement and Timing

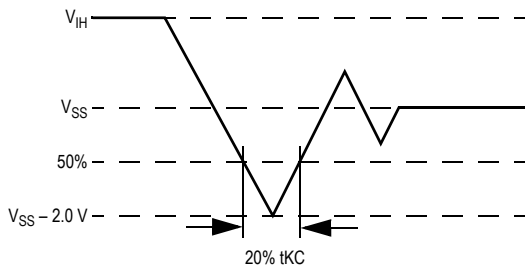

### Overshoot Measurement and Timing

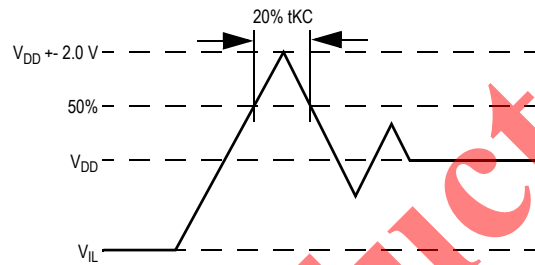

### Capacitance

( $T_A = 25^\circ\text{C}$ ,  $f = 1\text{ MHz}$ ,  $V_{DD} = 3.3\text{ V}$ )

Parameter	Symbol	Test conditions	Typ.	Max.	Unit
Control Input Capacitance	$C_I$	$V_{DD} = 3.3\text{ V}$	3	4	pF
Input Capacitance	$C_{IN}$	$V_{IN} = 0\text{ V}$	4	5	pF
Output Capacitance	$C_{OUT}$	$V_{OUT} = 0\text{ V}$	6	7	pF

**Note:**

This parameter is sample tested.

### AC Test Conditions

Parameter	Conditions
Input high level	2.3 V
Input low level	0.2 V
Input slew rate	1 V/ns
Input reference level	1.25 V
Output reference level	1.25 V
Output load	Fig. 1 & 2

**Notes:**

1. Include scope and jig capacitance.
2. Test conditions as specified with output loading as shown in Fig. 1 unless otherwise noted.
3. Output Load 2 for  $t_{LZ}$ ,  $t_{HZ}$ ,  $t_{OLZ}$  and  $t_{OHZ}$
4. Device is deselected as defined by the Truth Table.

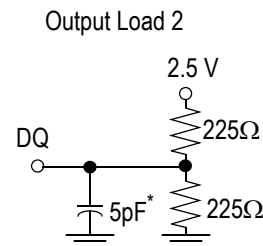
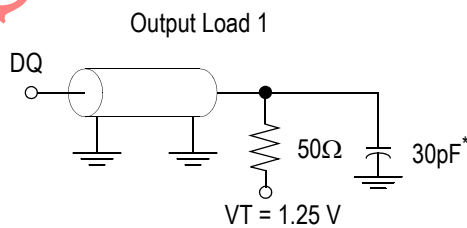

\* Distributed Test Jig Capacitance

**DC Electrical Characteristics**

Parameter	Symbol	Test Conditions	Min	Max
Input Leakage Current (except mode pins)	$I_{IL}$	$V_{IN} = 0 \text{ to } V_{DD}$	-1 $\mu\text{A}$	1 $\mu\text{A}$
ZZ Input Current	$I_{INZZ}$	$V_{DD} \geq V_{IN} \geq V_{IH}$ $0V \leq V_{IN} \leq V_{IH}$	-1 $\mu\text{A}$ -1 $\mu\text{A}$	1 $\mu\text{A}$ 300 $\mu\text{A}$
Mode Pin Input Current	$I_{INM}$	$V_{DD} \geq V_{IN} \geq V_{IL}$ $0V \leq V_{IN} \leq V_{IL}$	-300 $\mu\text{A}$ -1 $\mu\text{A}$	1 $\mu\text{A}$ 1 $\mu\text{A}$
Output Leakage Current	$I_{OL}$	Output Disable, $V_{OUT} = 0 \text{ to } V_{DD}$	-1 $\mu\text{A}$	1 $\mu\text{A}$
Output High Voltage	$V_{OH}$	$I_{OH} = -4 \text{ mA}$ , $V_{DDQ} = 2.375 \text{ V}$	1.7 V	
Output High Voltage	$V_{OH}$	$I_{OH} = -4 \text{ mA}$ , $V_{DDQ} = 3.135 \text{ V}$	2.4 V	
Output Low Voltage	$V_{OL}$	$I_{OL} = 4 \text{ mA}$		0.4 V

Discontinued Product

**Operating Currents**

Parameter	Test Conditions	Symbol	-180		-166		-150		-133		-100		-66		Unit
			0 to 70°C	-40 to 85°C	0 to 70°C	-40 to 85°C	0 to 70°C	-40 to 85°C	0 to 70°C	-40 to 85°C	0 to 70°C	-40 to 85°C	0 to 70°C	-40 to 85°C	
Operating Current	Device Selected; All other inputs $\geq V_{IH}$ or $\leq V_{IL}$ Output open	$I_{DD}$ Pipeline	155	160	140	145	130	135	115	120	90	95	65	70	mA
		$I_{DD}$ Flow Through	100	105	90	95	85	90	80	85	65	70	50	55	
Standby Current	$ZZ \geq V_{DD} - 0.2 V$	$I_{SB}$ Flow Through	10	15	10	15	10	15	10	15	10	15	10	15	mA
		$I_{DD}$ Pipeline	35	40	30	35	30	35	30	35	25	30	25	30	
Deselect Current	Device Deselected; All other inputs $\geq V_{IH}$ or $\leq V_{IL}$	$I_{DD}$ Flow Through	25	30	25	30	25	30	20	25	20	25	20	25	mA

## AC Electrical Characteristics

	Parameter	Symbol	-180		-166		-150		-133		-100		-66		Unit
			Min	Max	Min	Max	Min	Max	Min	Max	Min	Max	Min	Max	
Pipeline	Clock Cycle Time	t <sub>KC</sub>	5.5	—	6	—	6.6	—	7.5	—	10	—	12.5	—	ns
	Clock to Output Valid	t <sub>KQ</sub>	—	3.2	—	3.5	—	3.8	—	4	—	5	—	6	ns
	Clock to Output Invalid	t <sub>KQX</sub>	1.5	—	1.5	—	1.5	—	1.5	—	1.5	—	1.5	—	ns
	Clock to Output in Low-Z	t <sub>LZ</sub> <sup>1</sup>	1.5	—	1.5	—	1.5	—	1.5	—	1.5	—	1.5	—	ns
Flow Through	Clock Cycle Time	t <sub>KC</sub>	9.1	—	10	—	10.5	—	12	—	15	—	20	—	ns
	Clock to Output Valid	t <sub>KQ</sub>	—	8	—	8.5	—	9	—	10	—	12	—	18	ns
	Clock to Output Invalid	t <sub>KQX</sub>	3	—	3	—	3	—	3	—	3	—	3	—	ns
	Clock to Output in Low-Z	t <sub>LZ</sub> <sup>1</sup>	3	—	3	—	3	—	3	—	3	—	3	—	ns
	Clock HIGH Time	t <sub>KH</sub>	1.3	—	1.3	—	1.3	—	1.3	—	1.3	—	1.3	—	ns
	Clock LOW Time	t <sub>KL</sub>	1.5	—	1.5	—	1.5	—	1.5	—	1.5	—	1.5	—	ns
	Clock to Output in High-Z	t <sub>HZ</sub> <sup>1</sup>	1.5	3.2	1.5	3.5	1.5	3.8	1.5	4	1.5	5	1.5	6	ns
	$\bar{G}$ to Output Valid	t <sub>OE</sub>	—	3.2	—	3.5	—	3.8	—	4	—	5	—	6	ns
	$\bar{G}$ to output in Low-Z	t <sub>OLZ</sub> <sup>1</sup>	0	—	0	—	0	—	0	—	0	—	0	—	ns
	$\bar{G}$ to output in High-Z	t <sub>OHZ</sub> <sup>1</sup>	—	3.2	—	3.5	—	3.8	—	4	—	5	—	6	ns
	Setup time	t <sub>S</sub>	1.5	—	1.5	—	1.5	—	1.5	—	1.5	—	1.5	—	ns
	Hold time	t <sub>H</sub>	0.5	—	0.5	—	0.5	—	0.5	—	0.5	—	0.5	—	ns
	ZZ setup time	t <sub>ZZS</sub> <sup>2</sup>	5	—	5	—	5	—	5	—	5	—	5	—	ns
	ZZ hold time	t <sub>ZZH</sub> <sup>2</sup>	1	—	1	—	1	—	1	—	1	—	1	—	ns
	ZZ recovery	t <sub>ZZR</sub>	20	—	20	—	20	—	20	—	20	—	20	—	ns

## Notes:

1. These parameters are sampled and are not 100% tested.
2. ZZ is an asynchronous signal. However, in order to be recognized on any given clock cycle, ZZ must meet the specified setup and hold times as specified above.

### Pipeline Mode Timing

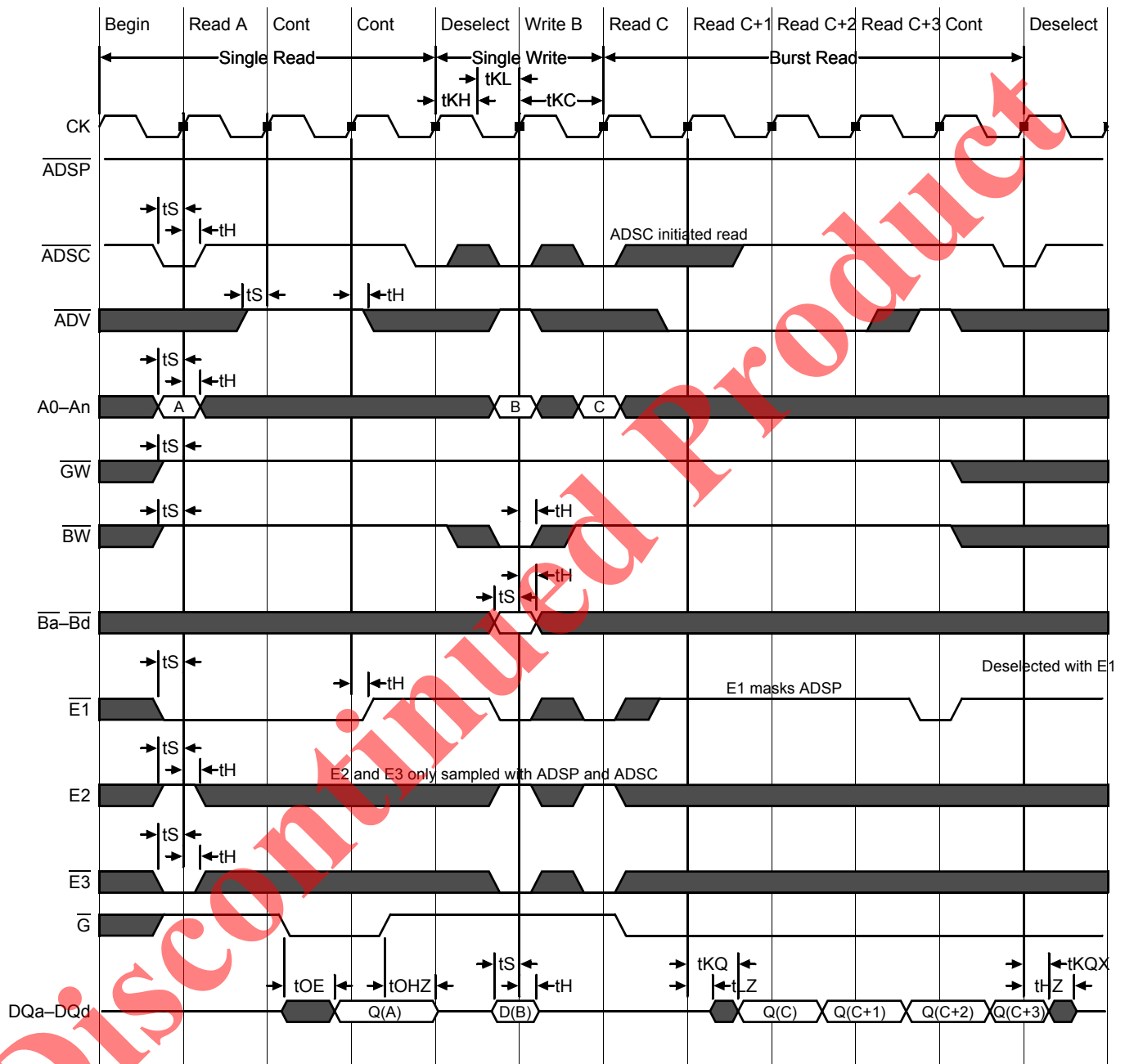

### Flow Through Mode Timing

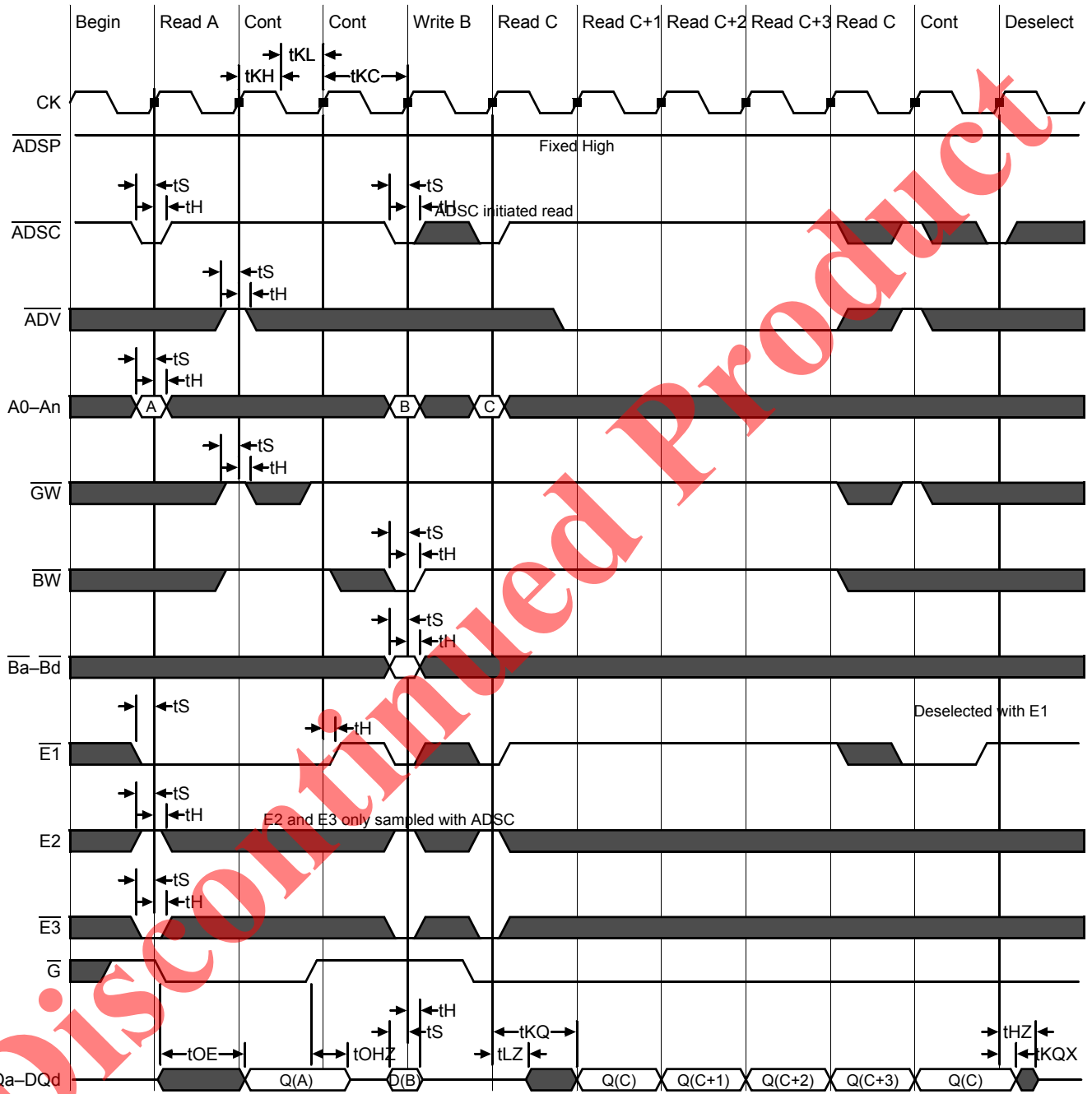

### Sleep Mode Timing

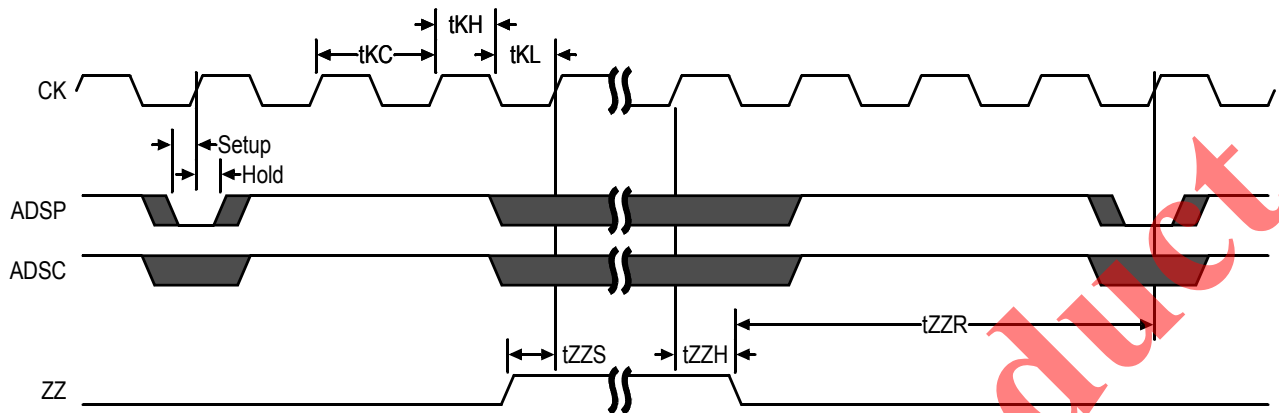

### Application Tips

#### Single and Dual Cycle Deselect

SCD devices force the use of “dummy read cycles” (read cycles that are launched normally, but that are ended with the output drivers inactive) in a fully synchronous environment. Dummy read cycles waste performance, but their use usually assures there will be no bus contention in transitions from reads to writes or between banks of RAMs. DCD SRAMs do not waste bandwidth on dummy cycles and are logically simpler to manage in a multiple bank application (wait states need not be inserted at bank address boundary crossings), but greater care must be exercised to avoid excessive bus contention.

GS82032A Output Driver Characteristics

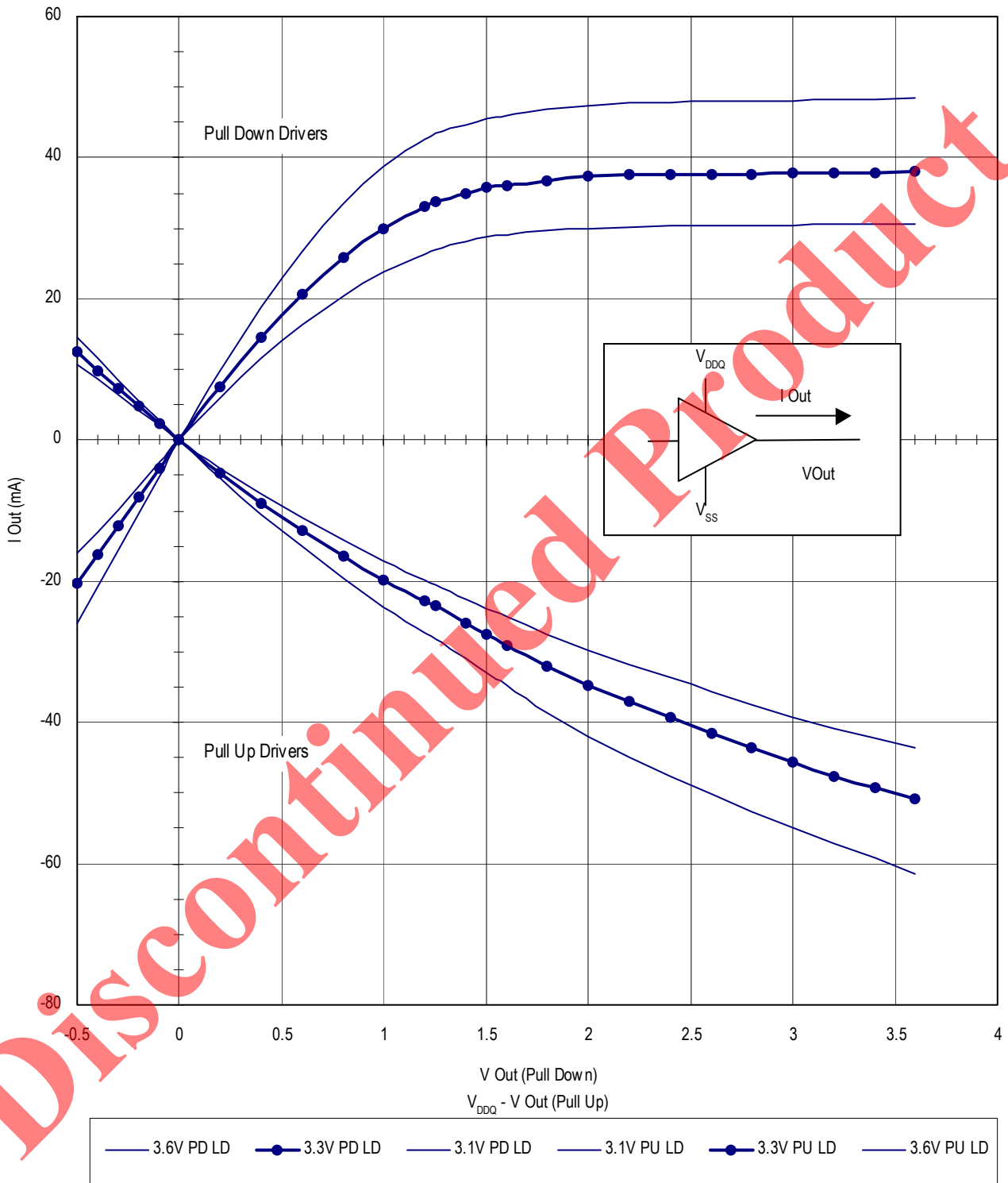

**TQFP Package Drawing (Package T)**

Symbol	Description	Min.	Nom.	Max
A1	Standoff	0.05	0.10	0.15
A2	Body Thickness	1.35	1.40	1.45
b	Lead Width	0.20	0.30	0.40
c	Lead Thickness	0.09	—	0.20
D	Terminal Dimension	21.9	22.0	22.1
D1	Package Body	19.9	20.0	20.1
E	Terminal Dimension	15.9	16.0	16.1
E1	Package Body	13.9	14.0	14.1
e	Lead Pitch	—	0.65	—
L	Foot Length	0.45	0.60	0.75
L1	Lead Length	—	1.00	—
Y	Coplanarity			0.10
$\theta$	Lead Angle	0°	—	7°

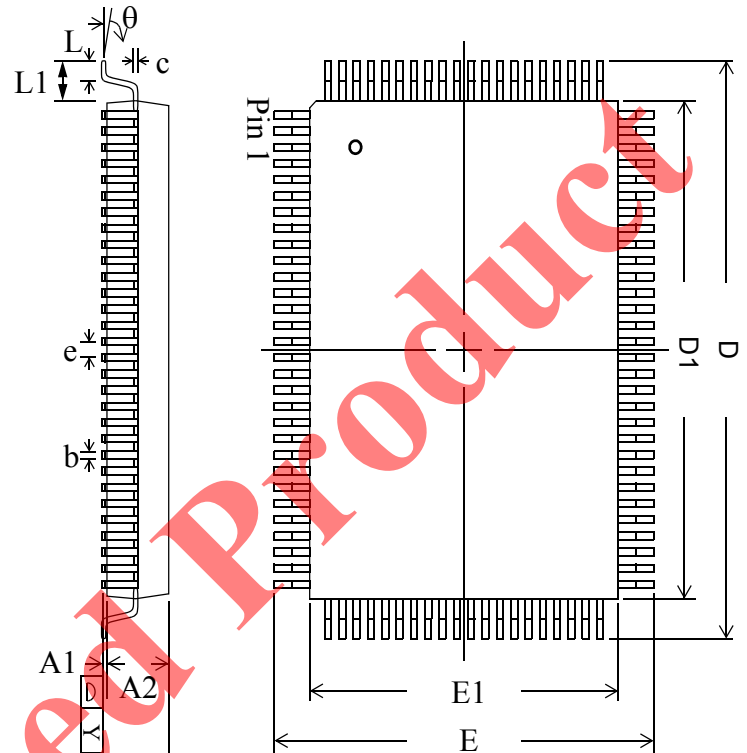
**Notes:**

1. All dimensions are in millimeters (mm).
2. Package width and length do not include mold protrusion.

**Ordering Information for GSI Synchronous Burst RAMs**

Org	Part Number <sup>1</sup>	Type	Package	Speed <sup>2</sup> (MHz/ns)	T <sub>A</sub> <sup>3</sup>
64K x 32	GS82032AT-180	Pipeline/Flow Through	TQFP	180/8	C
64K x 32	GS82032AT-166	Pipeline/Flow Through	TQFP	166/8.5	C
64K x 32	GS82032AT-150	Pipeline/Flow Through	TQFP	150/9	C
64K x 32	GS82032AT-133	Pipeline/Flow Through	TQFP	133/10	C
64K x 32	GS82032AT-100	Pipeline/Flow Through	TQFP	100/12	C
64K x 32	GS82032AT-66	Pipeline/Flow Through	TQFP	66/18	C
64K x 32	GS82032AT-4	Pipeline/Flow Through	TQFP	133/10	C
64K x 32	GS82032AT-5	Pipeline/Flow Through	TQFP	100/12	C
64K x 32	GS82032AT-6	Pipeline/Flow Through	TQFP	66/18	C
64K x 32	GS82032AT-180I	Pipeline/Flow Through	TQFP	180/8	I
64K x 32	GS82032AT-166I	Pipeline/Flow Through	TQFP	166/8.5	I
64K x 32	GS82032AT-150I	Pipeline/Flow Through	TQFP	150/9	I
64K x 32	GS82032AT-133I	Pipeline/Flow Through	TQFP	133/10	I
64K x 32	GS82032AT-100I	Pipeline/Flow Through	TQFP	100/12	I
64K x 32	GS82032AT-66I	Pipeline/Flow Through	TQFP	66/18	I
64K x 32	GS82032AT-4I	Pipeline/Flow Through	TQFP	133/10	I
64K x 32	GS82032AT-5I	Pipeline/Flow Through	TQFP	100/12	I
64K x 32	GS82032AT-6I	Pipeline/Flow Through	TQFP	66/18	I
64K x 32	GS82032AGT-180	Pipeline/Flow Through	RoHS-compliant TQFP	180/8	C
64K x 32	GS82032AGT-166	Pipeline/Flow Through	RoHS-compliant TQFP	166/8.5	C
64K x 32	GS82032AGT-150	Pipeline/Flow Through	RoHS-compliant TQFP	150/9	C
64K x 32	GS82032AGT-133	Pipeline/Flow Through	RoHS-compliant TQFP	133/10	C
64K x 32	GS82032AGT-100	Pipeline/Flow Through	RoHS-compliant TQFP	100/12	C
64K x 32	GS82032AGT-66	Pipeline/Flow Through	RoHS-compliant TQFP	66/18	C
64K x 32	GS82032AGT-4	Pipeline/Flow Through	RoHS-compliant TQFP	133/10	C
64K x 32	GS82032AGT-5	Pipeline/Flow Through	RoHS-compliant TQFP	100/12	C
64K x 32	GS82032AGT-6	Pipeline/Flow Through	RoHS-compliant TQFP	66/18	C
64K x 32	GS82032AGT-180I	Pipeline/Flow Through	RoHS-compliant TQFP	180/8	I
64K x 32	GS82032AGT-166I	Pipeline/Flow Through	RoHS-compliant TQFP	166/8.5	I
64K x 32	GS82032AGT-150I	Pipeline/Flow Through	RoHS-compliant TQFP	150/9	I

**Notes:**

- Customers requiring delivery in Tape and Reel should add the character "T" to the end of the part number. Example: GS82032AT-150IT.
- The speed column indicates the cycle frequency (MHz) of the device in Pipelined mode and the latency (ns) in Flow Through mode. Each device is Pipeline/Flow Through mode-selectable by the user.
- T<sub>A</sub> = C = Commercial Temperature Range. T<sub>A</sub> = I = Industrial Temperature Range.
- GSI offers other versions this type of device in many different configurations and with a variety of different features, only some of which are covered in this data sheet. See the GSI Technology web site ([www.gsistechnology.com](http://www.gsistechnology.com)) for a complete listing of current offerings.

**Ordering Information for GSI Synchronous Burst RAMs**

Org	Part Number <sup>1</sup>	Type	Package	Speed <sup>2</sup> (MHz/ns)	T <sub>A</sub> <sup>3</sup>
64K x 32	GS82032AGT-133I	Pipeline/Flow Through	RoHS-compliant TQFP	133/10	I
64K x 32	GS82032AGT-100I	Pipeline/Flow Through	RoHS-compliant TQFP	100/12	I
64K x 32	GS82032AGT-66I	Pipeline/Flow Through	RoHS-compliant TQFP	66/18	I
64K x 32	GS82032AGT-4I	Pipeline/Flow Through	RoHS-compliant TQFP	133/10	I
64K x 32	GS82032AGT-5I	Pipeline/Flow Through	RoHS-compliant TQFP	100/12	I
64K x 32	GS82032AGT-6I	Pipeline/Flow Through	RoHS-compliant TQFP	66/18	I

**Notes:**

- Customers requiring delivery in Tape and Reel should add the character "T" to the end of the part number. Example: GS82032AT-150IT.
- The speed column indicates the cycle frequency (MHz) of the device in Pipelined mode and the latency (ns) in Flow Through mode. Each device is Pipeline/Flow Through mode-selectable by the user.
- T<sub>A</sub> = C = Commercial Temperature Range. T<sub>A</sub> = I = Industrial Temperature Range.
- GSI offers other versions this type of device in many different configurations and with a variety of different features, only some of which are covered in this data sheet. See the GSI Technology web site ([www.gsistechnology.com](http://www.gsistechnology.com)) for a complete listing of current offerings.

**Revision History**

DS/Date Rev. Code: Old; New	Types of Changes Format or Content	Revisions
GS82032 Rev 1.03 2/ 2000D; GS820321.04 3/ 2000E	Content	• First Release of A version. Added “A” Version to 82032T/Q, 820E32TQ, and 820H32TQ
GS820321.04 3/2000E; GS82032A_r1_05	Content	• Updated ADSC in timing diagrams on pages 16 and 18
82032A_r1_05; 82032A_r1_06	Content	• Added 200 MHz, 180 MHz, and 166 MHz speed bins (all references updated) • Deleted 150 MHz, 138 MHz, and 66 MHz speed bins (all references deleted) • Deleted BGA reference in “Flow Through/Pipeline Reads” on page 1 • Updated entire datasheet with new standards
82032A_r1_06; 82032A_r1_07	Content	• Updated table on page 1 • Updated Operating Currents table on page 12 • Updated Electrical Characteristics table on page 13 • Updated format to comply with Technical Publications standards
82032A_r1_07; 82032A_r1_08	Content	• Added the following part numbers to the Ordering Information table on page 22: – GS82032AT-4 – GS82032AT-6 – GS82032AT-4I – GS82032AT-6I – GS82032AQ-4 – GS82032AQ-6 – GS82032AQ-4I – GS82032AQ-6I
82032A_r1_08; 82032A_r1_09	Content	• Removed all references to 200 MHz parts (no longer active)
82032A_r1_09; 82032A_r1_10	Content	• Complete rewrite of datasheet in order to reflect parts available
82032A_r1_10; 82032A_r1_11	Content	• Reactivated 180 MHz speed bin • Updated format
82032A_r1_11; 82032A_r1_12	Content	• Added Pb-free information for TQFP
82032A_r1_12; 82032A_r1_13	Content	• Updated Pb-free to RoHS-compliant