

Preliminary

T-41-91



Am79h1000T/Am79h1000R

1300nm Fiber Optic Transmitter/Receiver

Advanced
Micro
Devices

- **Reliable 1300 nanometer MOVPE ELED (Am79h1000T)**
- **Reliable InGaAs/InP planar MOVPE PIN photodiode (Am79h1000R)**
- **Full electrical and optical FDDI compliance**
- **FDDI SUPERNET™ and TAXI™ compatible**
- **Single 5.0 V power supply operation**
- **18dB typical loss budget for Am79h1000T/Am79h1000R link**
- **High speed: Up to 175 Mbaud**
- **Differential ECL I/O**
- **Integral ST® connector**
- **Compact 14-pin DIP package**
- **Low power consumption**
 - Am79h1000T: 600 mW typical
 - Am79h1000R: 400 mW typical
- **Performance optimized for 125 Mbps operation**

GENERAL DESCRIPTION

The Am79h1000 is a high-speed fiber-optic transmitter/receiver pair designed for digital data transmission through optical fiber cable.

The Am79h1000T data link transmitter converts differential ECL signals to lightwaves in the 1300nm band. The Am79h1000T operates from a single 5 V power supply, connected for either ECL or pseudo-ECL operation. The transmitter contains a Transmit Disable input allowing control over the optical output level. The In-GaAs/InP high-speed ELED is fabricated with the Metal-Organic Vapor Phase Epitaxy (MOVPE) process for high reliability, performance and consistency.

The Am79h1000R converts lightwaves in the 1300nm band to differential ECL signals. Operation is from a single +5 V power supply. The InGaAs/InP high-performance planar PIN photodiode is manufactured with the MOVPE process for high reliability and product consistency.

The Am79h1000 set is ideally suited for direct interface with the FDDI SUPERNET Encoder/Decoder and ENDEC Data Separator. For point-to-point applications, the Am79h1000 links directly coupled with the TAXIchip™ set provides the complete byte-wide parallel interface to light output solution.

BLOCK DIAGRAM

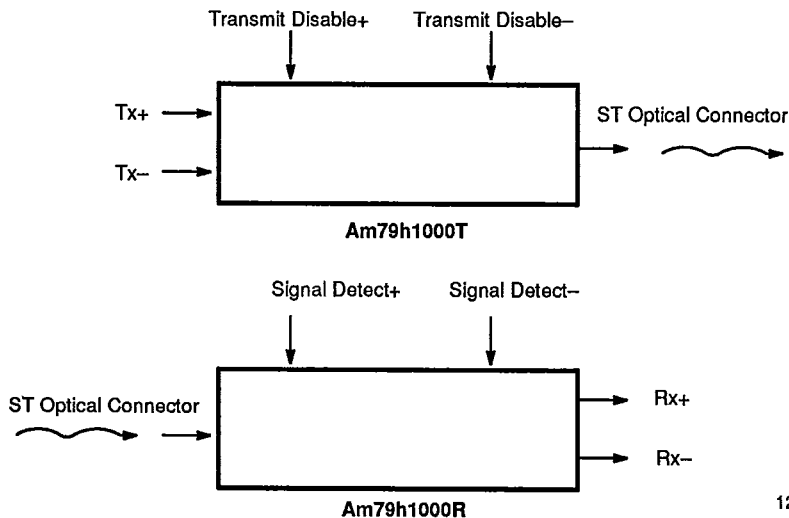

12677-001A

SUPERNET, TAXI, and TAXIchip are trademarks of Advanced Micro Devices, Inc.
ST is a registered trademark of AT&T, Inc.

Publication # 12677 Rev. A Amendment 1.0
Issue Date: July 1989

T-41-91

RELATED AMD PRODUCTS

Part No.	Description
Am79C81A	Ram Buffer Controller
Am79C82A	Data Path Controller
Am79C83	Fiber Optic Ring Media Access Controller
Am7984A	Encoder Decoder (ENDEC)
Am7985A	ENDEC Data Separator
Am7968-125	TAXIchip Transmitter
Am7969-125	TAXIchip Receiver

CONNECTION DIAGRAMS

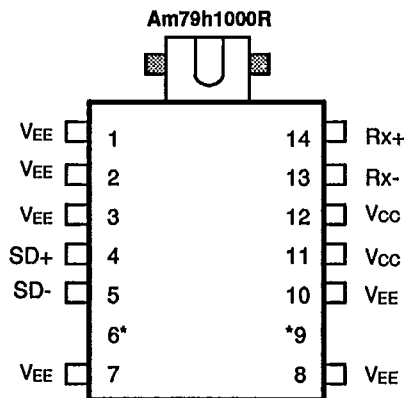
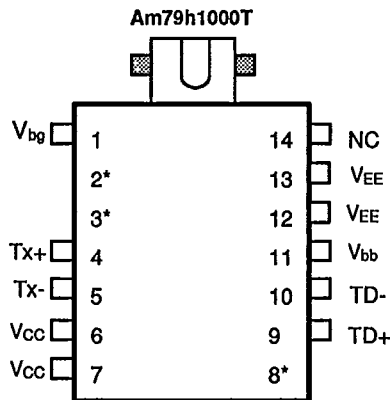

* No PIN

12677-002A

T-41-91

ORDERING INFORMATION

Standard Products

AMD standard products are available in several packages and operating ranges. The ordering number (Valid Combination) is formed by a combination of:

- a. Device Number
- b. Transmit/Receiver Option

AM79h1000

T



a. Device Number/Description
Am79h1000 1300 Data Link

b. Transmitter/Receiver option
T = Transmitter
R = Receiver

Valid Combinations	
AM79h1000T	
AM79h1000R	

Valid Combinations

Valid Combinations list configurations planned to be supported in volume for this device. Consult the local AMD sales office to confirm availability of specific valid combinations, to check on newly released combinations, and to obtain additional data on AMD's standard military grade products.

T-41-91

PIN DESCRIPTION**Am79h1000T Transmitter****Tx+, Tx-****Transmit Data+, Transmit Data- (Differential ECL Inputs)**

Tx+ and Tx- are the digital logic inputs for the transmitter. A logic one at the inputs results in High Optical Output.

TD+, TD-**Transmit Disable+, Transmit Disable- (Differential ECL Inputs)**

The Transmit Disable inputs control the optical output independently of the input data at Tx+ or Tx-. A logical one to the transmit disable inputs disables the optical port. In a pseudo-ECL system ($V_{CC} = +5.0V$), with TD- connected to V_{bg} , a TTL HIGH at TD+ will disable the output. To hardwire the transmitter enabled, regardless of power supply configuration, connect Transmit Disable+ to V_{bg} and Transmit Disable- to V_{bb} .

 V_{bb} , V_{bg} **Output Voltage References**

V_{bb} and V_{bg} are internally generated voltage references used to bias Transmit Disable and Transmit Data inputs for single-ended operation.

 V_{CC} **Power Supply**

V_{CC} is at ground potential for direct ECL interface. For TTL, pseudo-ECL or CMOS levels, V_{CC} is a +5.0V nominal power supply pin.

 V_{EE} **Power Supply**

V_{EE} is a -5.2V nominal supply for direct ECL interface. For TTL, CMOS or pseudo-ECL levels, V_{EE} is at ground potential.

Am79h1000R Receiver**Rx+, Rx-****Received Data+, Received Data- (Differential ECL Outputs)**

Rx+ and Rx- are the digital logic outputs for the receiver. A logic one at the output corresponds to HIGH optical input.

SD+, SD-**Signal Detection+, Signal Detection- (Differential ECL Outputs)**

Signal Detect is an optical power alarm indicating insufficient optical intensity for conversion. A logic zero (Signal Detect+ = LOW, Signal Detect- = HIGH) indicates that the optical signal is too weak for conversion.

 V_{CC} **Power Supply**

V_{CC} is a +5.0V nominal power supply pin.

 V_{EE} **Power Supply**

V_{EE} is always at ground potential.

FUNCTIONAL DESCRIPTION**Am79h1000T Transmitter**

The Am79h1000T converts a digital electrical input signal to an optic output signal. The Tx+ and Tx- inputs bring serial electrical data to the transmitter for conversion to the 1300nm light output. The data is received through a differential comparator input which requires a minimum 100mv signal swing. A logic one at the Tx inputs results in high optical output. The Tx inputs can be driven directly from an ECL or pseudo-ECL source with proper line termination. To drive the transmitter data inputs from a TTL or CMOS logic level, Tx- is connected to V_{bg} and input data to Tx+.

The Transmit Disable function of the Am79h1000T fully extinguishes the optical output signal irrespective of the Tx data inputs. The transmit disable signals are received through a differential comparator input. A logic one (TD+ more positive than TD- by 200 mV) disables the optical output. Output biases V_{bg} and V_{bb} may be used to provide a variety of active control possibilities, or to hardwire the transmitter enabled. To hardwire the

transmitter enabled connect TD+ to V_{bg} and TD- to V_{bb} . To enable the transmitter with an active high signal, connect TD+ to V_{bg} and logic HIGH control to TD- enables the output. To disable with an active HIGH level, connect TD- to V_{bg} and a control signal HIGH to TD+ disables the transmitter.

Am79h1000R Receiver

The Am79h1000R converts optical input signals to digital electrical output signals. The Rx+ and Rx- outputs are complementary pseudo-ECL. HIGH optical input corresponds to a logic one at the outputs.

The Am79h1000R Receiver contains complimentary "signal detect" outputs that flag low optical signal power. When the optical signal is sufficient, the signal detect output is a logical one. The assert/deassert parameters comply with the specifications of the FDDI PMD standard. The assert light level is typically -34dBm and the deassert level is -36dBm. Either or both signal detect output of the Am79h1000R may be left unconnected.

T-41-91

APPLICATIONS

Am79h1000T/R Connection with the Am7968/69 TAXIchip set

For serial data links operating up to 100 Mbit/sec, the TAXIchip set is a unique solution that supplies the fundamental functional needs for a complete system interface: a parallel TTL interface to the system, serial (+5V) PECL interface to the transmission line (cable), encoding/decoding and auto synchronization.

For a fiber optic link, an optical transmitter and receiver pair is required. The Am79h1000 is the solution for converting electrical signals into optical signals and vice versa at 1300nm. The use of a TAXIchip set in conjunction with Am79h1000 gives a simple and complete solution for this optical link implementation.

The two pairs can be easily configured for a complete interface (figure 1). A common power supply (+5V) and similar logic levels (pseudo ECL) ease the interface requirements. The TAXI Transmitter's (Am7968) serial outputs feed the inputs of Am79h1000T and the TAXI Receiver's (Am7969) serial inputs are fed by the Am79h1000R outputs. The resistors shown at the serial outputs of the Am7968 and the Am79h1000R are pull-down resistors to correctly bias the output stages.

The interconnections of the TAXIs and the Am79h1000s should be kept as short as possible (best if under one inch), due to the high frequency signals on these connections.

Refer to the TAXI data sheet and the TAXI Technical manual for additional information.

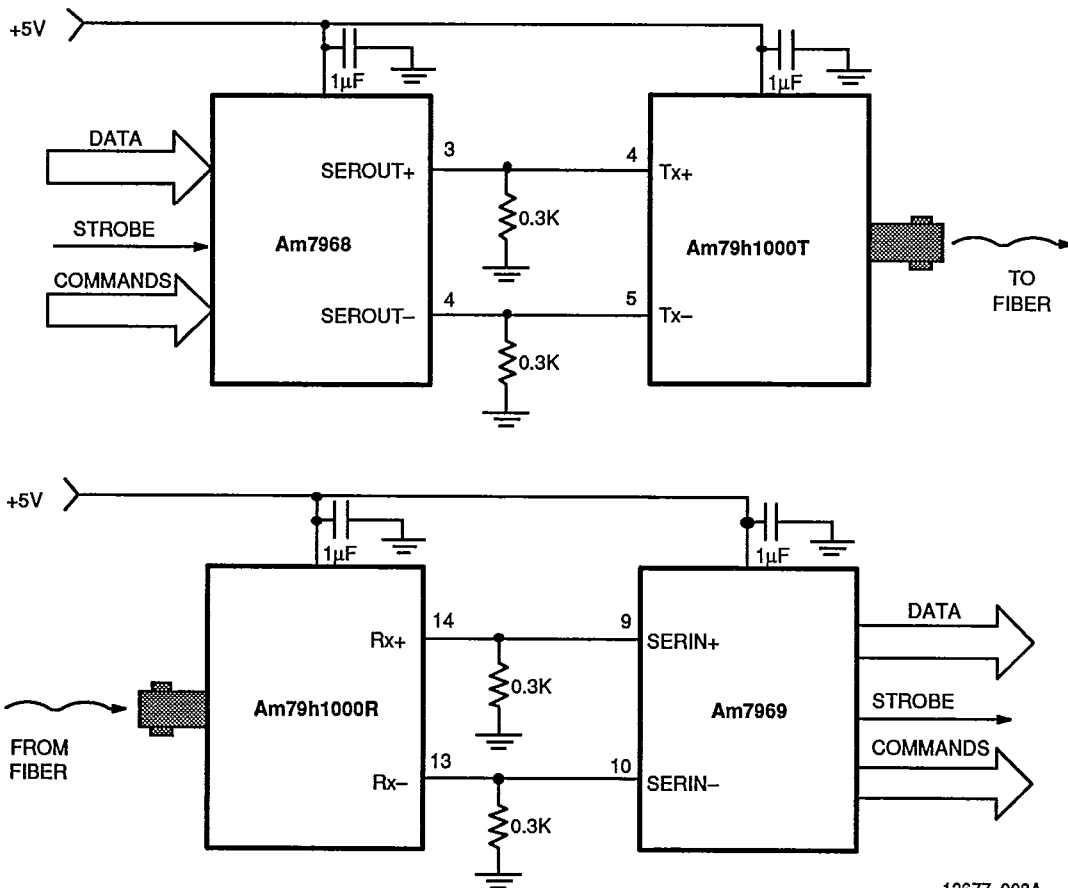

12677-003A

Figure 1. Transmitter and Receiver Connections

ABSOLUTE MAXIMUM RATINGS

Power Supply Voltage (V_{CC} or V_{EE})	0 to + 6.0 V
Input Voltage	V_{EE} to V_{CC} V
Output Current (V_{bb} and V_{bg})	-1 to 1 mA
Output Current (Rx and Signal Defect Outputs)	+30 mA
Storage Temperature	-20 to +85°C
Relative Humidity	non-condensing (%R H)
Soldering Temperature	240/10°C/secs

OPERATING RANGES

Temperature (T_a)	0 to + 70°C
Supply Voltage [$V_{CC} - V_{EE}$]	+4.5 to + 5.7 V

Operating ranges define those limits between which the functionality of the device is guaranteed.

Stresses above those listed under Absolute Maximum Ratings may cause permanent device failure. Functionality at or above these limits is not implied. Exposure to Absolute Maximum Ratings, for extended periods of time, may affect device reliability.

PERFORMANCE CHARACTERISTICS over operating range unless otherwise specified
Am79h1000T

PARAMETER	MIN	TYP	MAX	UNITS
Center Wavelength	1270	1300	1380	nm
Spectral Width (FWHM)		80	120	nm
Optical Output Power (average 50 duty cycle into 62.5 μ m core; 0.275 NA fiber)	-19.0 (12.5)	-15.5 (28)	-14.0 (40)	dBm (μ W)
Optical Rise and Fall Time (10%–90%)	0.6	2	3	ns
Total Pulse Width Distortion (peak) ¹			0.6	ns
Extinguished Optical Output Power ²		0	30	nW
Minimum Differential Input for Full Optical Response		100		mV
High Level Input Current		50		μ A
Transmit Disable Response Time		100	1000	ns
Output Voltage at V_{bb} with Respect to V_{CC}	-1.5	-1.3	-1.1	V
Output Voltage at V_{bg} with Respect to V_{EE}	1.1	1.3	1.5	V
Current Consumption ³		120	160	mA
Transmission Distance ⁴	5			Km

Notes:

1. With FDDI Standard Test Pattern.
2. With Logical 0 data input or Logical 1 Transmit Disable input.
3. Typical consumption figure is at 25°C, 5.0 V supply. Maximum consumption is at 70°C, 5.7 V supply.
4. With fiber of appropriate intermodal bandwidth.

PERFORMANCE CHARACTERISTICS Over operating range unless otherwise specified**Am79h1000R**

PARAMETER	MIN	TYP	MAX	UNITS
Optical Input Center Wavelength	1270	1300	1380	nm
Sensitivity for 2.5E-10 BER at 125 Mbaud ^{1,6}		-34 (0.4)	-31 (0.8)	dBm (μW)
Maximum Operating Optical Input Power ^{1,6}	-14 (40)	-12 (63)		dBm (μW)
Input Pulse Duration (0 or 1)	5		1000	ns
Input Duty Cycle	40	50	60	%
Total Pulse Width Distortion (peak) ^{1,2}			0.7	ns
Signal Detect must Assert Input Power			-31	dBm
BER at which Signal Detect must De-Assert			0.01	BER
Signal Detect Hysteresis	1.5			dB
Signal Detect Assertion Time			100	μs
Signal Detect De-Assertion Time			350	μs
Rx+ and Rx- Output Rise and Fall Times	0.5	1	1.5	ns
Output High Voltage with Respect to V _{CC} ³	-1.0		-0.7	V
Output Low Voltage with Respect to V _{CC} ³	-2.0		-1.6	V
Current Consumption ^{4,5}		80	120	mA
Operating Distance ⁷	5			Km

Notes:

1. With FDDI Standard Test Pattern, both Receiver data outputs PECL terminated.
2. At -20 dBm Average Optical Input Power.
3. All outputs at 25°C and are 10KH ECL, with V_{EE} grounded, and V_{CC} +5 V nominal (so called Pseudo-ECL, PECL).
4. Typical consumption figure is at 25°C, 5.0 V supply. Maximum consumption is at 70°C, 5.7 V supply.
5. Excludes current drawn from output loads.
6. Average optical input power from 62.5 μm core; 0.275 NA fiber.
7. With fiber of appropriate intermodal bandwidth.

T-41-91

PHYSICAL DIMENSION*

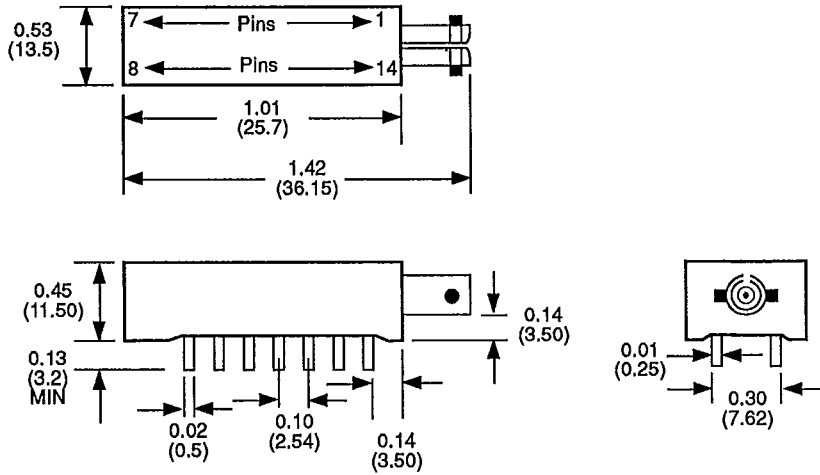

12677-004A

* For reference only. All dimensions are measured in inches (millimeters). BSC is an ANSI standard for Basic Space Centering.