

Features

- Operating voltage: 2.4V~5.0V
- Programmable speech synthesizer
- Programmable tone melody generator
- ADPCM, PCM synthesis
- Internal voice ROM
- Range of voice sampling rate:
4kHz~10kHz for PCM synthesis
4kHz~8kHz for ADPCM synthesis
- Voice & Melody mixed output
- 2-channel voice mixed output
- 2-channel melody mixed output
- 11 kinds of melody beats
- 5 octaves of tone level and 16 tempos
- 16 level digital volume control
- High performance current type D/A output
- 8 programmable outputs
- Powerful user-defined functions
- Power-on initial setting

Applications

- High-end educational toys
- Alert & warning systems
- Speech synthesizers & sound effect generators

General Description

The HT83XXX family is a series of programmable speech synthesizers and tone generators designed for user-defined voice and sound effect applications. It provides various sampling rates for speech synthesizers, 5 octaves of tone level, 11 kinds of melody beats, 16 tempos, and a high quality current type D/A output with 16 levels of volume control. The LSI provides some pow-

erful bodies like HT83V31, HT83V32, HT83V33 and HT83V34 for user's various applications. The user's commands, along with the programmable registers of the HT83XXX, embody powerful programmable functions and flexible structures. Thus, the HT83XXX series is suitable for versatile voice and sound effect applications.

ROM Selection Table

The HT83XXX series provides various voice capacity as shown below:

Body	HT83060	HT83120	HT83180	HT83240	HT83360	HT83480*	HT83720*	HT83960*
ROM	128Kb	256Kb	384Kb	512Kb	768Kb	1024Kb	1536Kb	2048Kb

*: Under development.

The HT83XXX provides four kinds of powerful bodies for user's various applications.

Body	Key No.	LED No.	Voice Synthesis	Voice Output CH	Melody Output CH
HT83V31	1~32	8	PCM/ADPCM (3 bit)	1	2
HT83V32	1~64	4	PCM	2	2
HT83V33	1~64	4	PCM/ADPCM	1	2
HT83V34	1~32	8	PCM/ADPCM (4 bit)	1	2

Pin Assignment

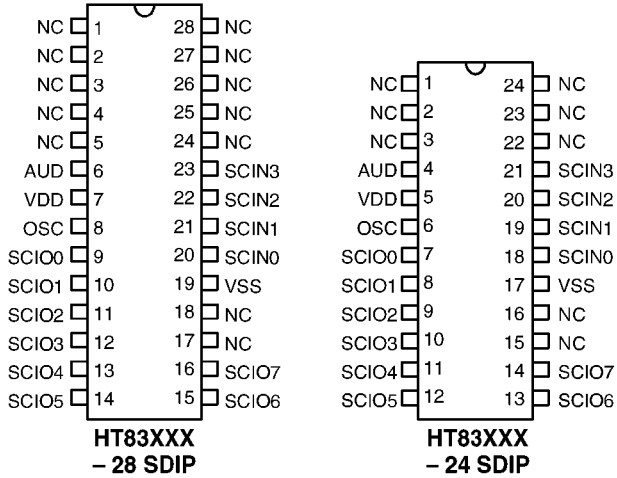

Block Diagram

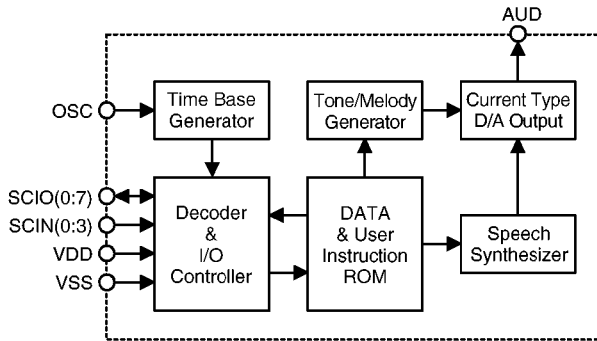

Pad Assignment (HT83060)

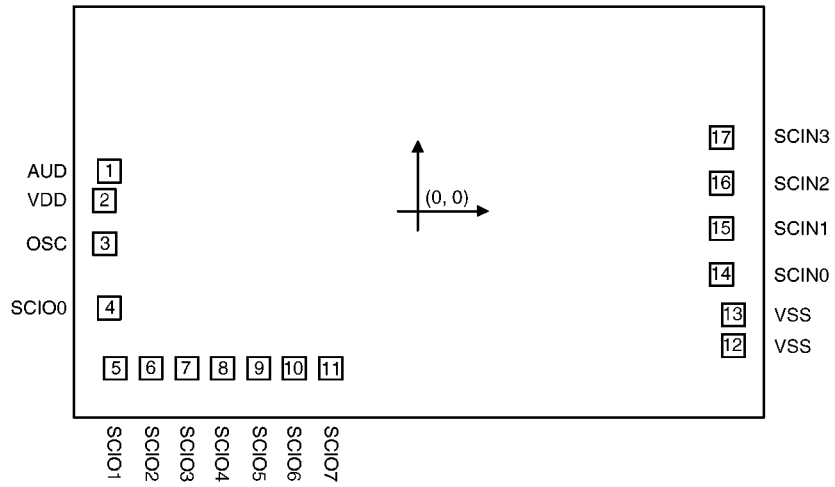

Chip size: $3620 \times 2300 \text{ (}\mu\text{m)}^2$

* The IC substrate should be connected to VSS in the PCB layout artwork

Unit: μm^2

Pad No.	X	Y	Pad No.	X	Y
1	-1617.35	211.3	10	-646.75	-824.5
2	-1642.35	55.8	11	-455.35	-824.5
3	-1639.95	-170.70	12	1653.35	-705.8
4	-1616.25	-507.2	13	1653.35	-543.2
5	-1585.65	-824.5	14	1592.75	-331.5
6	-1399.85	-824.5	15	1592.75	-91.9
7	-1209.05	-824.5	16	1592.75	148.1
8	-1023.55	-824.5	17	1592.75	387.7
9	-832.25	-824.5			

Pad Assignment (HT83120)

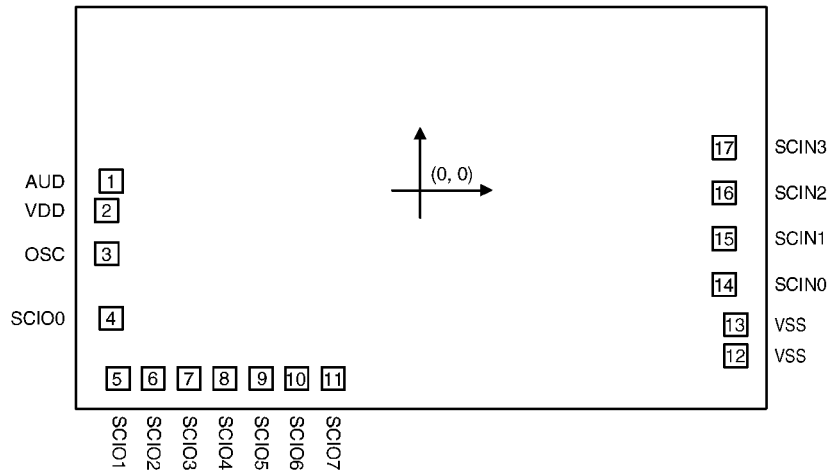

Chip size: $3620 \times 2620 \text{ (}\mu\text{m)}^2$

* The IC substrate should be connected to VSS in the PCB layout artwork.

Unit: μm^2

Pad No.	X	Y	Pad No.	X	Y
1	-1617.35	48.5	10	-646.75	-987.3
2	-1642.35	-107	11	-455.35	-987.3
3	-1639.95	-333.5	12	1653.35	-868.6
4	-1616.25	-670	13	1653.35	-706
5	-1585.65	-987.3	14	1592.75	-494.3
6	-1399.85	-987.3	15	1592.75	-254.7
7	-1209.05	-987.3	16	1592.75	-14.7
8	-1023.55	-987.3	17	1592.75	224.9
9	-832.25	-987.3			

Pad Assignment (HT83180)

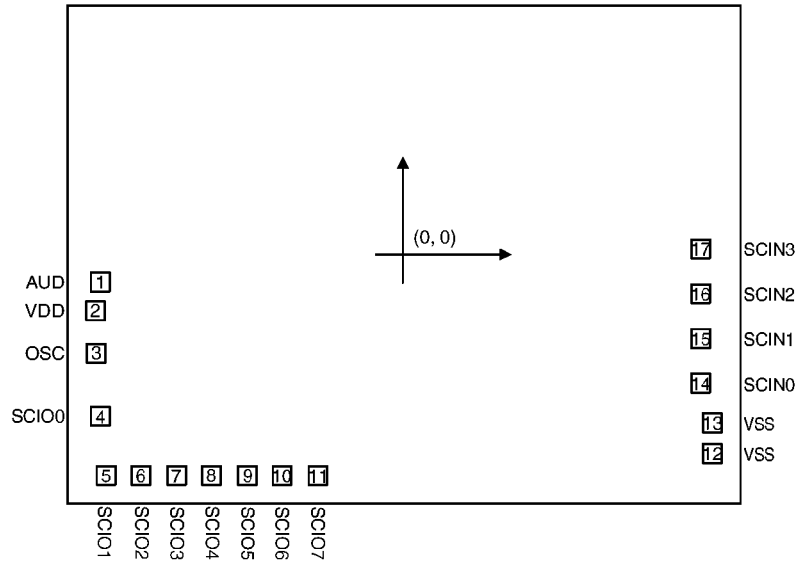

Chip size: 3620 × 3010 (μm)²

* The IC substrate should be connected to VSS in the PCB layout artwork.

Unit: μm²

Pad No.	X	Y	Pad No.	X	Y
1	-1617.35	-147.15	10	-646.75	-1182.95
2	-1642.35	-302.65	11	-455.35	-1182.95
3	-1639.95	-529.15	12	1653.35	-1064.25
4	-1616.25	-865.65	13	1653.35	-901.65
5	-1585.65	-1182.95	14	1592.75	-689.95
6	-1399.85	-1182.95	15	1592.75	-450.35
7	-1209.05	-1182.95	16	1592.75	-210.35
8	-1023.55	-1182.95	17	1592.75	29.25
9	-832.25	-1182.95			

Pad Assignment (HT83240)

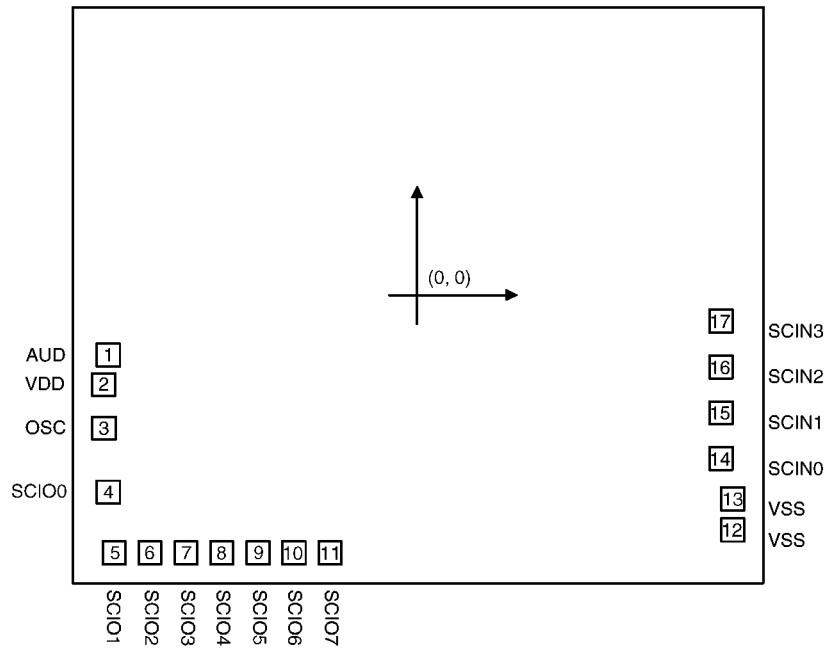

Chip size: $3620 \times 3350 (\mu\text{m})^2$

* The IC substrate should be connected to VSS in the PCB layout artwork.

Unit: μm^2

Pad No.	X	Y	Pad No.	X	Y
1	-1617.35	-314.10	10	-646.75	-1349.90
2	-1642.35	-469.60	11	-455.35	-1349.90
3	-1639.95	-696.60	12	1653.35	-1231.20
4	-1616.25	-1032.60	13	1653.35	-1068.60
5	-1585.65	-1349.90	14	1592.75	-856.90
6	-1399.85	-1349.90	15	1592.75	-617.30
7	-1209.05	-1349.90	16	1592.75	-377.30
8	-1023.55	-1349.90	17	1592.75	-137.70
9	-832.25	-1349.90			

Pin Description

Pin Name	I/O	Internal Connection	Description
SCIN (0:3)	I	Wake-up Pull-High	Trigger inputs They can also be configured as wake-up inputs
SCIO (0:7)	I/O	Pull-High or NMOS Open Drain	Bi-directional I/O pins They can be optioned as trigger inputs or LED outputs
AUD	O	PMOS Open Drain	Audio output for driving an external transistor
OSC	I	—	Built-in RC oscillator An oscillation resistor is connected between OSC and VSS
VDD	I	—	Positive power supply
VSS	I	—	Negative power supply (GND)

Absolute Maximum Ratings

 Supply Voltage $-0.3V$ to $6V$

 Storage Temperature $-50^{\circ}C$ to $125^{\circ}C$

 Input Voltage $V_{SS}-0.3V$ to $V_{DD}+0.3V$

 Operating Temperature $-20^{\circ}C$ to $70^{\circ}C$
Electrical Characteristics

Symbol	Parameter	Test Condition		Min.	Typ.	Max.	Unit
		V _{DD}	Condition				
V _{DD}	Operating Voltage	—	—	2.4	—	5.2	V
I _{DD}	Operating Current	3V	No load, f _{sys} =4MHz	—	1	2	mA
I _{STB}	Standby Current	3V	No load, system HALT	—	5	10	μA
I _{OL}	SCIO (0:7) Sink Current	3V	V _{OL} =0.3V	4	6	—	mA
f _{sys}	System Frequency	3V	R _{OSC} =120KΩ	—	4.0	—	MHz

Functional Description

The HT83XXX series is a series of programmable speech synthesizers and tone generators. It provides various sampling rates for speech synthesizers and 5 octaves of tone level for tone/melody generators. The speech source can be coded as PCM or ADPCM format through HOLTEK's tools. This family embodies 4 trigger inputs and 8 programmable I/O pins. With such flexible functions, the HT83XXX can be expanded up to 64 trigger inputs. The user's instructions are employed to develop new and customized functions for a wide variety of innovative applications.

Speech and melody analysis

The speech and melody sources of HT83XXX can be recorded and edited from a PC sound card and media tools. HOLTEK's CAD tools first load a speech source file as .WAV or .PCM format, then transfer the speech file as PCM or ADPCM format, and finally save it to the internal mask ROM by changing a layer of the mask. The PCM format generates a higher sound quality whereas the ADPCM format brings about a longer recording capacity. The melody source can either be in the .MID or in the .MLD format.

System architecture

- **KEY Function Definition**

For the HT83V31 type, the HT83XXX provides 2 trigger registers EN_F & EN_R to define the trigger keys active function, falling edge or rising edge trigger. For the HT83V32 or HT83V33 type, all of the trigger keys are defined as falling edge active only. The EN_F register is to define falling edge trigger dis-

able/enable and the EN_R register is to define rising edge trigger disable/enable.

- **Working registers – R0, R1**

The HT83V31 offers two working registers, i.e., R0 and R1. The HT83V32 & HT83V33 offer four working registers, i.e., R0~R3. They usually store the frequently accessed intermediate results. A location jump makes a very efficient use of the working registers as the address pointer.

- **Mode registers – MODE1, MODE2**

There are two operation modes, namely; DIRECT mode and MATRIX mode, in the HT83V31, and are defined by the MODE1 and MODE2 registers, respectively. After the power is turned on, the operation mode has to be set first. Only one mode can be chosen at a time, otherwise the system will go to an unpredictable state. In the DIRECT mode, the SCIN0~SCIN3 pins are always set as trigger inputs and the SCIO4~SCIO7 pins as LED outputs. As for the SCIO0~SCIO3 pins, they are defined by the MODE1 register and set as trigger inputs or LED outputs.

In the MATRIX mode, the SCIN0~SCIN3 pins are always set as matrix inputs and SCIO4~SCIO7 pins as matrix outputs. As for the SCIO0~SCIO3 pins, they are defined by the MODE2 register and set as matrix inputs or LED outputs.

- **LED control registers – LED_M0, LED_M1, LED_N0, LED_N1**

The HT83XXX provides four LED control registers, namely; LED_M0, LED_M1, LED_N0, LED_N1. They define the LED output patterns and LED active numbers. A maximum of

TG7	TG6	TG5	TG4	TG3	TG2	TG1	TG0
b8	b7	b5	b4	b3	b2	b1	b0
0: The bit map trigger keys are disabled							
1: The bit map trigger keys are enabled							

EN_F & EN_R Register definition

two LED output patterns can be set at a time and are defined by the LED_M0 and LED_M1 registers. The LED_M0 and LED_M1 registers are mapped to the LED_N0 and LED_N1 registers to decide the active LED numbers of each pattern. The LED output pattern table and the active LED numbers are shown below.

The LED display function can be set either as synchronous or sequential display. For synchronous display, LED_N0&LED_M0 and LED_N1&LED_M1 are used to define 2 sets of LED display groups. LED_Nn (n=0,1) defines the active numbers of each display group, and LED_Mn (n=0,1) determines the display pattern of each display group. On the other hand, for sequential display, LED_N0 & LED_M0 and LED_N1&LED_M1 are em-

ployed to define a set of LED display groups. LED_N0 defines the active numbers of the LED display group, LED_N1 defines the active numbers of the pattern one time display, and LED_M0 defines the display pattern. LED_M1 however, is invalid.

After the LED_M0 & LED_N0 and LED_M1 & LED_N1 registers are both set, and the chip is activated as well, the LEDs will output a pattern defined in the LED_Mn (n=0 or 1) register. If these registers fail to reset, the LED output patterns turn out to be the same as the patterns of the previous output. Given this, if a new LED pattern has been defined, the previous LED pattern should be disabled. To disable the previous LED pattern, LED_Nn has to be reset.

7	6	5	4	3	2	1	0
SCIO7	SCIO6	SCIO5	SCIO4	SCIO3	SCIO2	SCIO1	SCIO0

Direct mode: To set SCIO0~SCIO3 as input/output pins
 0: To set the selected pin as LED output
 1: To set the selected pin as direct key input
 Note: If one of the SCIO4~SCIO7 pins is set as "1", it means that the selected LED is disabled.
 The default value is 00001111b.

MODE1 Register

7	6	5	4	3	2	1	0
SCIO7	SCIO6	SCIO5	SCIO4	SCIO3	SCIO2	SCIO1	SCIO0

Matrix mode: To set SCIO0~SCIO7 as input/output pins
 0: To set the selected pin as LED output
 1: To set the selected pin as a matrix input for SCIO0~SCIO3 or a matrix output for SCIO4~SCIO7
 The default value is 11110000b.

MODE2 Register definition

LED_MX (0:7)	Synchronous		Sequential	
6,7 Flash Rate	00: 1Hz 10: 6Hz	01: 3Hz 11: 12Hz	00: 1Hz* 10: 6Hz	01: 3Hz 11: 12Hz
5 LED Duty	0: 1/4 duty	1: Full duty	Fixed 3/4 duty	
4 LED Type	0: Voice	1: Tempo	0: Voice	1: Tempo
3 Rotation Mode	—		0: Left	1: Right
2 Flash/Volume	0: Flash	1: Volume	0: Flash	1: Volume
1 Reserved	—		—	
0 Display Mode	0: Synchronous		1: Sequential	

Note: 1. The default value is 00H.
2. “—”: Reserved function

LED_M0 & LED_M1 registers definition

7	6	5	4	3	2	1	0
LED7	LED6	LED5	LED4	LED3	LED2	LED1	LED0

LED enable/disable definition (The default value is 00H.)
0: Disabled
1: Enabled

LED_N0 & LED_N1 registers definition

Current type D/A output

The HT83XXX series supplies a high accuracy current type of D/A output pin for audio outputs. The output volume is changeable from 0 to 15 digital levels by writing a value to the VOL register in the audio equation. The D/A pin is a PMOS open drain structure and outputs synthesized signals for driving a speaker through an external NPN transistor when the chip is active. However, it becomes floating when the chip is in the standby state. An 8050 type transistor with $h_{FE}=150$ is recommended for the output driver of the D/A output pin.

Melody/Tone generator

The HT83XXX family embodies a melody/tone generator. The generator can generate 11 different kinds of melody beats, 5 octaves of tone level, 16 tempos, and 2 channels of output. Of these components, the melody tempo is change-

able and generates sound effects by writing a control value to the TMP register in the audio equation. The chip provides the following 16 tempos, 11 beats, and 5 octaves for user's programming.

- 16 tempos (Beats/Min.)

68	100	125	156
78	109	132	179
86	114	139	192
93	119	147	229

- 11 beats

$\frac{1}{24}, \frac{1}{12}, \frac{1}{8}, \frac{1}{6}, \frac{1}{4}, \frac{1}{3}, \frac{1}{2}, \frac{3}{4}, 1, 2$

- 5 octaves

C1~B1, C2~B2, C3~B3, C4~B4, C5~B5

PCM/ADPCM synthesizer

The HT83XXX family contains a PCM & ADPCM synthesizer. The synthesizer offers a wide range of sampling rates from 4kHz to 10kHz for PCM synthesis and 4kHz to 8kHz for ADPCM synthesis. It also supports a small variety of 100Hz. The voice output sampling rate of the synthesizer can be changed by writing a control value to the SAM register in the audio equation. For a higher performance sound quality, the PCM coding is required. But for a longer recording capacity, the ADPCM coding is recommended.

Power on initialization

The HT83XXX embodies a POWON key word to define the LSI initial state. After the chip is initialized, the following condition can be set. But if the initial condition is not set, the default condition will take place.

- Enter the standby state or active state (default: standby state) after turning on the power supply
- LED output pattern definition: LED_M0, LED_M1 (default: 00H)
- LED activate number definition: LED_N0, LED_N1 (default: 00H)

Application Circuits

HT83V31/HT83V34 Type – Direct mode (4 Keys/8 LEDs)

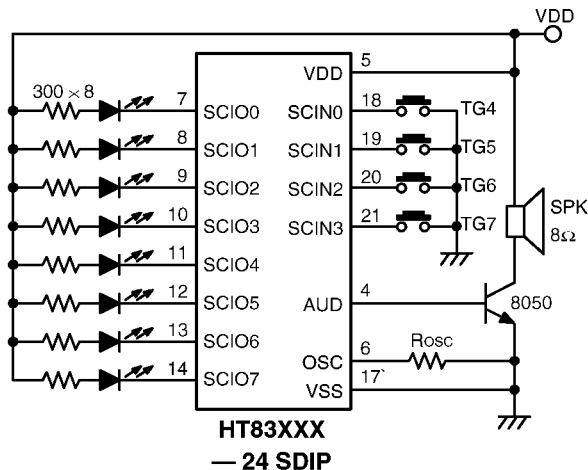

Oscillator configuration

The HT83XXX series provides an RC oscillator for the system clock. The system oscillator stops in the standby state so as to reduce power consumption.

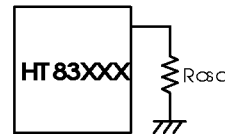

For the oscillator circuit, an external resistor is required between OSC and VSS. The oscillator frequency is typically 4MHz for an external resistor of 120KΩ. The RC type of oscillator offers the most cost-effective solution, although the frequency of the oscillation may vary with temperature and the chip itself due to process variation.

Mask options

The following options have to be defined to ensure a proper system functioning:

- Pull-high resistor: 33K/98K
- Key debounce time: 0ms~255ms

HT83V31/HT83V34 Type – Direct mode (8 keys/4 LEDs)

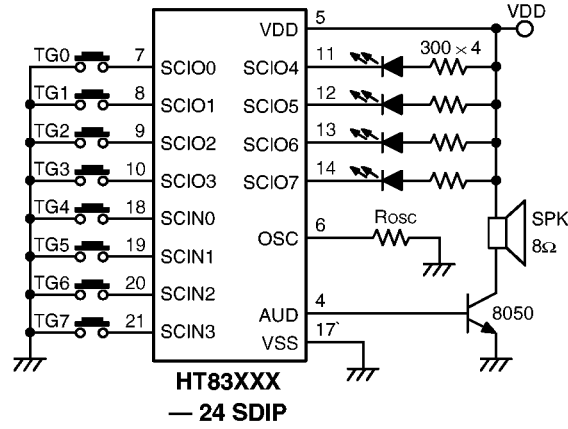

HT83V31/HT83V34 Type – Matrix mode (32 keys)

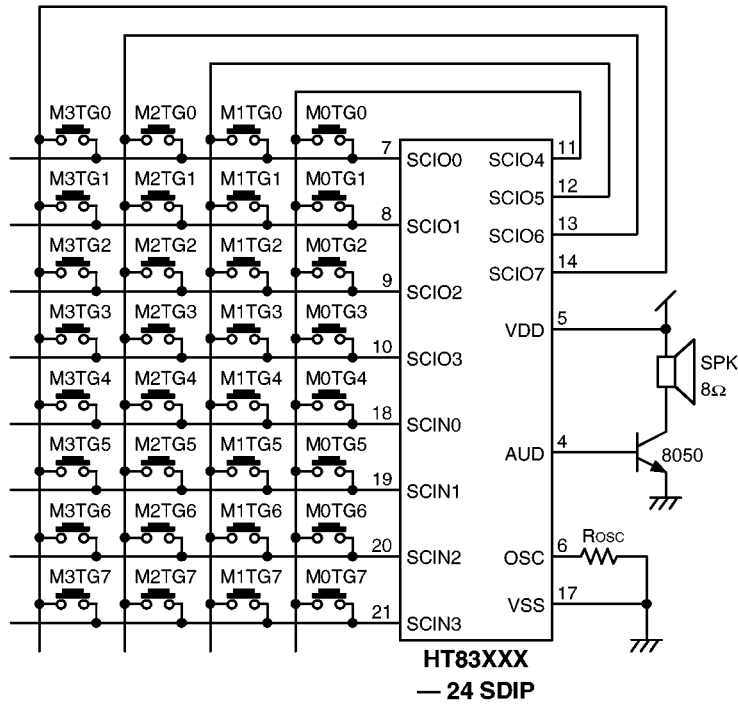

HT83V32/HT83V33 Type – Matrix mode (64 keys)

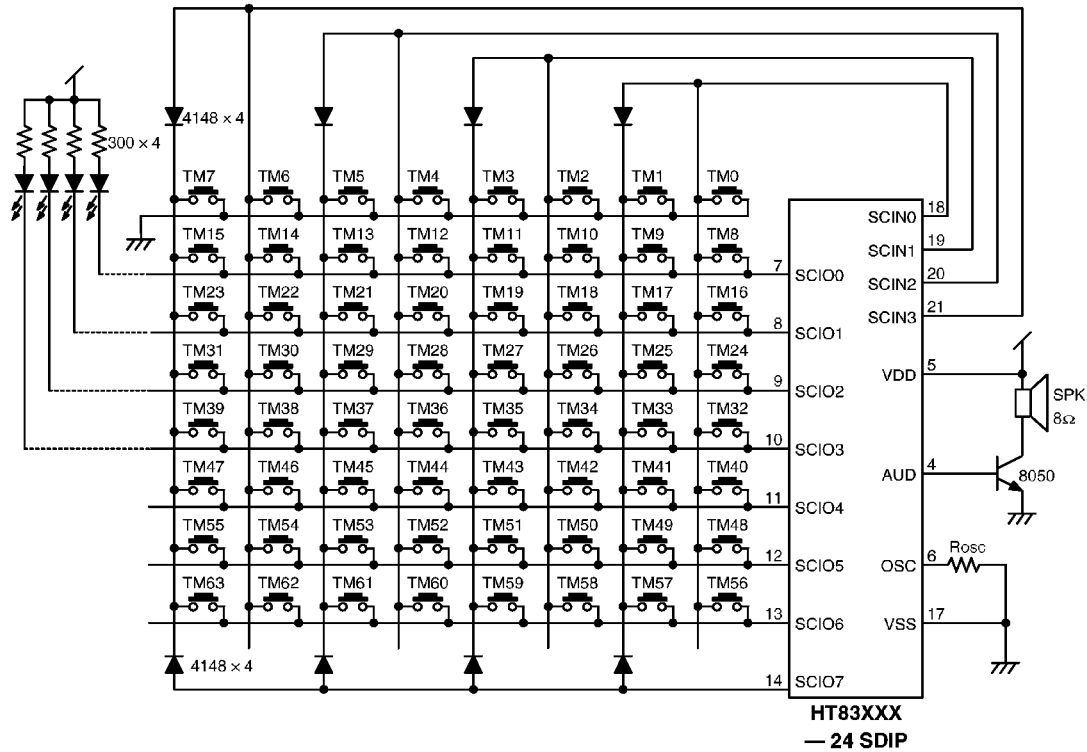

Application Notes

The HT83XXX series provides four kinds of control bodies HT83V31, HT83V32, HT83V33 and HT83V34 for various applications. The four bodies can simulate all functions of the Magic Voice.

Block Diagram

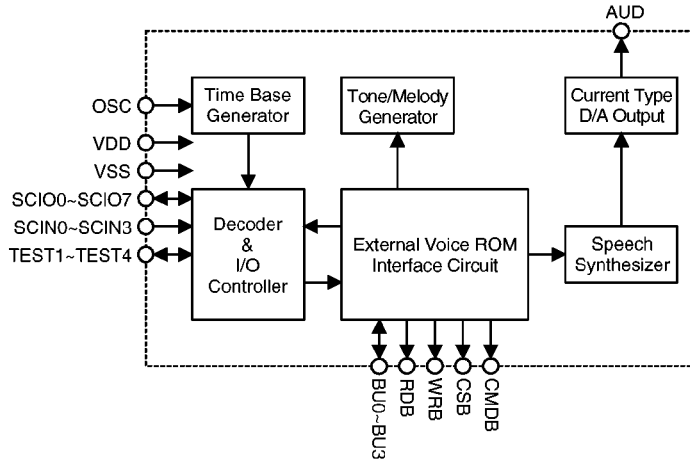

Pin Assignment

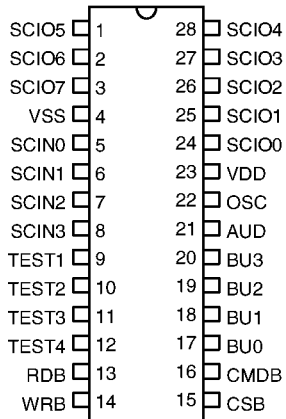

HT83V31/HT83V32
HT83V33/HT83V34
 - 28 SDIP

Pin Description

Pin Name	I/O	Internal Connection	Description
SCIN0~ SCIN3	I	Wake-up Pull-High	Trigger inputs These pins can be defined as direct trigger or matrix trigger inputs. They can also be configured as wake-up inputs
SCIO0	I/O	Wake-up Pull-High CDS/Normal Input	Bi-directional I/O pin This pin can be defined as schmitt trigger input or an NMOS open drain output. It can also be configured as wake-up input
SCIO1~ SCIO7	I/O	Wake-up Pull-High	Bi-directional I/O pins These pins can be defined as trigger inputs or LED function outputs. They can also be configured as wake-up inputs
AUD	O	PMOS Open Drain	Audio output for driving an external transistor
OSC	I	—	Built-in RC oscillator An oscillation resistor is connected between OSC and VSS
VDD	I	—	Positive power supply
VSS	I	—	Negative power supply (GND)
TEST (1:4)	I/O	COMS I/O	For IC test only
BU (0:3)	I/O	CMOS I/O	Data buses for LSI with a voice ROM
RDB	O	CMOS Output	Read enable output pin
WRB	O	CMOS Output	Write enable output pin
CSB	O	CMOS Output	Chip selection enable output pin
CMDB	O	CMOS Output	Command write enable output pin

Instruction Set
Command layer instruction set (HT83V31/HT83V34)

Instruction	Description	Default Value
MOV LED_Mn, Operand	LED_Mn ← operand; n=0 or 1	00H
MOV LED_Nn, Operand	LED_Nn ← operand; n=0 or 1	00H
MOV MODEn, Operand	MODEn ← operand; n=1 or 2	MODE1=0FH MODE2=F0H
MOV EN_F (R), Operand	EN_F (R) ← operand	00H
MOV Rn, Label	Move the address indicated by the label to Rn; n=0 or 1,	
STGn_L	Skip if the TGn is in the low_level state; n=0~7,	
STGn_H	Skip if the TGn is in the high_level state; n=0~7,	
JMP Rn	Unconditionally jumps to the address indicated by Rn; n=0 or 1,	
JMP Label	Unconditionally jumps to the address indicated by the label,	
CALL AUD_N	Unconditionally calls an audio subroutine located in the audio equation,	
STOP	Stop all activities and enter the standby state,	

Audio equation layer instruction set

Instruction	Description	Range
MLD_FILE * n	Define the local repeating number of the melody file	1~255
PCM_FILE * n	Define the local repeating number of PCM format file	1~255
ADPCM_FILE * n	Define the local repeating number of ADPCM format file	1~255
HT8_FILE * n	Define the local repeating number of HOLTEK's tone format file	1~255
SIL=X	Set the length of silence	0~2000ms
SET LED_Mn, Operand	LED_Mn ← operand; n=0 or 1,	
SET LED_Nn, Operand	LED_Nn ← operand; n=0 or 1,	
SET EN_F (R), Operand	EN_F (R) ← operand,	
SET VOL, X	Set the sound volume	0~15
SET TMP, X	Set the rate of tempo	0~255
SET SAM, X	Set the voice sampling rate	4kHz~10kHz
END	Stop the audio equation and return to the main program	

Instruction Definition

Command layer instruction

MOV LED_Mn, operand	LED_Mn ← operand, where n=0 or 1																		
Description	This instruction defines the LED output pattern by loading a set of 8-bit data to the register LED_Mn. The default value of the register LED_Mn is 00H.																		
Example	MOV LED_M0, 40H																		
MOV LED_Nn, operand	LED_Nn ← operand, where n=0 or 1																		
Description	This instruction enables/disables the LED output by loading a set of 8-bit data to the register LED_Nn. The default value of the register LED_Nn is 00H.																		
Example	MOV LED_N0, A0H; enables LED7 and LED5, and the others are all disabled.																		
MOV MODEn, operand	MODEn ← operand, where n=1 or 2																		
Description	This instruction sets TG (0:3)/LED (0:3) as trigger input or as LED output by loading a set of 8-bit data to the register MODEn. The default values of the registers MODE1 and MODE2 are 0FH and F0H, respectively.																		
Example	MOV MODE1, A5H; set as the DIRECT mode																		
MOV EN_F(R), operand	EN_F (R) ← operand																		
Description	This instruction enables/disables the falling (rising) edge of each of the eight TG (0:7) trigger inputs by loading a set of 8-bit data to the registers EN_F and EN_R. The default values of the registers are all 00H.																		
	<table border="1" style="border-collapse: collapse; text-align: center; width: 100%;"> <thead> <tr> <th>Bit</th> <th>7</th> <th>6</th> <th>5</th> <th>4</th> <th>3</th> <th>2</th> <th>1</th> <th>0</th> </tr> </thead> <tbody> <tr> <th>TG</th> <td>TG7</td> <td>TG6</td> <td>TG5</td> <td>TG4</td> <td>TG3</td> <td>TG2</td> <td>TG1</td> <td>TG0</td> </tr> </tbody> </table>	Bit	7	6	5	4	3	2	1	0	TG	TG7	TG6	TG5	TG4	TG3	TG2	TG1	TG0
Bit	7	6	5	4	3	2	1	0											
TG	TG7	TG6	TG5	TG4	TG3	TG2	TG1	TG0											
	0: Disabled 1: Enabled																		
Example	MOV EN_F, 00001111B; sets TG0~TG3 as falling triggers MOV EN_R, 00110011B; sets TG0, TG1, TG4, TG5 as rising triggers																		
MOV Rn, label	Move the address indicated by the label to Rn, where n=0, 1																		
Description	This instruction loads a label value to the working registers R0 and R1. The label value represents any position of the program when a jump instruction is executed.																		
Example	JMP R0																		

JMP Rn	Unconditionally jumps to the address indicated by Rn, where n=0, 1
Description	This instruction jumps indirectly to any position in the program that is indicated by the value currently stored in the register Rn, where n=0 or 1.
Example	JMP R0
JMP LABEL	Unconditionally jumps to the address indicated by the label
Description	This instruction jumps directly to the position corresponding to the label indicated.
Example	JMP AAA
CALL AUD_n	Unconditionally calls an audio subroutine located in the audio equation, when n=0~255
Description	This instruction unconditionally calls an audio subroutine located at the indicated address in the audio equation. Once the audio subroutine is processed, it returns to the main program and continues executing the next instruction.
Example	CALL AUD_3
STGn_L (H)	Skip if TGn is at the low (high) level state, where n=0~7
Description	This instruction skips the next instruction if the trigger input n is at the low_level (high_level) state; otherwise the next instruction will be processed.
Example	STG4_L
STOP	Stop all activities and enter the standby state
Description	This instruction ceases all activities of the chip. For any trigger input to be activated, this instruction is required when the functional description ends; otherwise an unpredictable state will appear.
Example	STOP

Audio equation layer instruction

SET LED_Mn, operand	LED_Mn ← operand, where n=0 or 1
Description	The function of this instruction is the same as the function of the instruction “MOV LED_Mn, operand” in the main program instruction set.
Example	SET LED_M0, 40H SET LED_M1, 08H

SET LED_Nn, operand	LED_Nn ← operand, where n=0 or 1
Description	The function of this instruction is the same as the function of the instruction “MOV LED_Nn, operand” in the main program instruction set.
Example	SET LED_N0, 0FH SET LED_N1, F0H
SET EN_F (R), operand	EN_F (R) ← operand
Description	The function of this instruction is the same as the function of the instruction “MOV EN_F (R), operand” in the main program instruction set.
Example	SET EN_R, 0AH
SET VOL, X	Set the sound volume
Description	This instruction is used to set the sound output volume. The output level can be set from 0 to 15.
Example	SET VOL, 8
SET TMP, X	Set the rate of tempo
Description	This instruction is used to set the melody tempo. The rate can be from 0 to FFH.
Example	SET TMP, 100
SET SAM, X	Set the voice sampling rate
Description	This instruction sets the voice sampling rate when synthesized voices are output. The range of the sampling rate is from 4000 (4kHz) to 10000 (10kHz).
Example	SET SAM, 6000
SIL=X	Set the length of silence
Description	This instruction sets the length of silence. The length of silence can be set from 0ms to 2 seconds.
Example	SIL=1FFFH

Instruction Set
Command layer instruction set (HT83V32/HT83V33)

Instruction	Description	Default Value
MOV LED_Mn, x	Move an immediate data to LED_Mn; n=0 or 1	00H
MOV LED_Nn, x	Move an immediate data to LED_Nn; n=0 or 1	00H
MOV Rn, x	Move an immediate data to Rn; n=0, 1 or 2,	
MOV Rm, Rn	Move the value of Rn to Rm; m, n=0, 1 or 2,	
SWAP Rm, Rn	Swap the data of Rm and Rn; m, n=0, 1, 2 or 3,	
AND R2, x	Logical AND immediate data to R2,	
OR R2, x	Logical OR immediate data to R2,	
CSNE R2, x	Compare R2 with immediate data, skip if not equal,	
CSNE R2, R0	Compare R2 with R0, skip if not equal,	
SZ R2.n	Skip if the n-bit of R2 is zero,	
JMP Rn	Unconditionally jumps to the address indicated by Rn; n=0 or 1,	
RANDOM R0	Move a random value to R0,	
TBLRD R0, ADDR	Move the ROM code R0,	
CLR WDT	Clear watchdog timer,	
CALL R0	Subroutine call addressed by R0,	
CALL ADDR	Subroutine call,	
INC Rn	Increment Rn; n=0 or 2,	
DEC Rn	Decrement Rn; n=0 or 2,	
NOP	No operation,	
STOP	Stop all activities and enter the standby state,	
RET	Return from subroutine,	

Audio equation layer instruction set

Instruction	Description	Range
MLD_FILE * n	Define the local repeating number of the melody file	1~255
PCM_FILE * n	Define the local repeating number of PCM format file	1~255
ADPCM_FILE * n	Define the local repeating number of ADPCM format file	1~255
HT8_FILE * n	Define the local repeating number of HOLTEK's tone format file	1~255
SIL=X	Set the length of silence	0~2000ms
SET LED_Mn, Operand	LED_Mn ← operand; n=0 or 1,	
SET LED_Nn, Operand	LED_Nn ← operand; n=0 or 1,	
SET EN_F (R), Operand	EN_F (R) ← operand,	
SET VOL, X	Set the sound volume	0~15
SET TMP, X	Set the rate of tempo	0~255
SET SAM, X	Set the voice sampling rate	4kHz~10kHz
END	Stop the audio equation and return to the main program	

Instruction Definition
Command layer instruction

MOV LED_Mn, x	Move an immediate data to LED_Mn; n=0 or 1
Description	This instruction defines the LED output pattern by loading a set of 8-bit data to the register LED_Mn. The default value of the register is 00H.
Example	MOV LED_M0, 40H
MOV LED_Nn, x	Move an immediate data to LED_Nn; n=0 or 1
Description	This instruction enables/disables the LED output by loading a set of 8-bit data to the register LED_Nn. The default value of the register is 00H.
Example	MOV LED_N0, 03H
MOV Rn, x	Move an immediate data to Rn; n=0, 1 or 2
Description	This instruction is to load an immediate data, or data indicated by the label to the working register Rn; where n=0, 1 or 2.
Example	MOV R0, 3

MOV Rm, Rn	MOV Rn to Rm; m, n=0, 1 or 2
Description	This instruction is to copy the contents of the Rn register to the Rm register.
Example	MOV R0, R2
SWAP Rm, Rn	Swap the data of Rm and Rn; m, n=0, 1, 2 or 3
Description	The contents of the Rm register and Rn register are interchanged.
Example	SWAP R3, R2
AND R2, x	Logical AND immediate data to R2
Description	Data in the register R2 and the specified data performs a bitwise logical_AND operation. The result is stored in the register R2.
Example	AND R2, 0CH
OR R2, x	Logical OR immediate data to R2
Description	Data in the register R2 and the specified data performs a bitwise logical_OR operation. The result is stored in the register R2.
Example	OR R2, 10H
CSNE R2, x	Compare R2 with immediate data, skip if not equal
Description	Data in the register R2 and the specified data performs a comparison. If the result is not equal, the next instruction is skipped, otherwise the instruction is executed.
Example	CSNE R2, 2FH
CSNE R2, R0	Compare R2 with R0, skip if not equal
Description	Data in the register R2 and R0 performs a comparison. If the result is not equal, the next instruction is skipped, otherwise the instruction is executed.
Example	CSNE R2, R0
SZ R2.N	Skip if the n-bit of R2 is zero
Description	If the bit n of the register R2 is zero, the next instruction is skipped, otherwise the instruction is executed.
Example	SZ R2.3
JMP Rn	Unconditionally jumps to the address indicated by Rn; n=0 or 1
Description	The program counter is replaced with the contents of the Rn unconditionally, and control is passed to this destination; where n=0 or 1.
Example	JMP R0

JMP LABEL	Unconditional jump
Description	The program counter is replaced with the directly-specified address unconditionally, and control is passed to this destination.
Example	JMP ABS
RANDOM R0	Move a random value to R0
Description	The random counter will generate a random value, and store the value to the register R0.
Example	RANDOM R0
TBLRD R0, ADDR	Move the ROM code to R0
Description	The data of ROM code addressed by the label is moved to the register R0.
Example	TBLRD R0, OP_CODE
CLR WDT	Clear watchdog timer
Description	The WDT and the WDT Prescaler are cleared.
Example	CLR WDT
CALL R0	Subroutine call addressed by R0
Description	The instruction unconditionally calls a subroutine located at the indicated address in R0. Program execution continues with the instruction at this address.
Example	CALL R0
INC Rn	Increment Rn; n=0 or 2
Description	Data in the register Rn is incremented by one.
Example	INC R0
DEC Rn	Decrement Rn; n=0 or 2
Description	Data in the register Rn is decremented by one.
Example	DEC R2
NOP	No operation
Description	No operation is performed. Execution continues with the next instruction.
Example	NOP
RET	Return from subroutine
Description	The program counter is restored from the stack.
Example	RET

STOP	Stop all activities and enter the standby state
Description	This instruction stops all operation and turn off the system clock.
Example	STOP
Audio equation layer instruction	
SET LED_Mn, operand	LED_Mn ← operand, where n=0 or 1
Description	The function of this instruction is the same as the function of the instruction “MOV LED_Mn, operand” in the main program instruction set.
Example	SET LED_M0, 40H SET LED_M1, 08H
SET LED_Nn, operand	LED_Nn ← operand, where n=0 or 1
Description	The function of this instruction is the same as the function of the instruction “MOV LED_Nn, operand” in the main program instruction set.
Example	SET LED_N0, 0FH SET LED_N1, F0H
SET VOL, X	Set the sound volume
Description	This instruction is used to set the sound output volume. The output level can be set from 0 to 15.
Example	SET VOL, 8
SET TMP, X	Set the rate of tempo
Description	This instruction is used to set the melody tempo. The rate can be from 0 to FFH.
Example	SET TMP, 100
SET SAM, X	Set the voice sampling rate
Description	This instruction sets the voice sampling rate when synthesized voices are output. The range of the sampling rate is from 4000 (4kHz) to 10000 (10kHz).
Example	SET SAM, 6000
SIL=X	Set the length of silence
Description	This instruction sets the length of silence. The length of silence can be set from 0ms to 2 seconds.
Example	SIL=1FFFFH

Application Diagram

