

1241/1243/1245-Type Uncooled Laser Transmitter

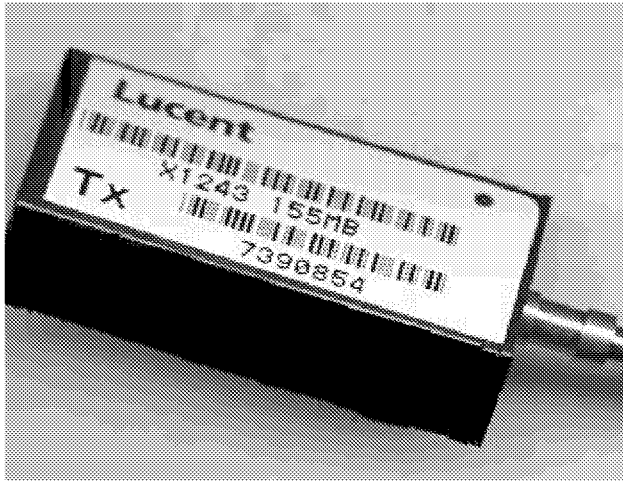

Offering multiple output power options and SONET/SDH compatibility, the 1241/1243-Type Uncooled Laser Transmitter is manufactured in a 20-pin, plastic DIP with a single-mode fiber pigtail.

Features

- Backward compatible with 1227/1229/1238-Type Laser Transmitters
- Space-saving, self-contained, 20-pin DIP
- Uses field-proven, reliable InGaAsP MQW laser
- Requires single 5 V power supply
- SONET/SDH compatible
- Uncooled laser with automatic optical power control for constant output power over case temperature range
- No thermoelectric cooler required; reduces size and power consumption
- Uses low-power dissipation CMOS technology
- Qualified to meet the intent of Bellcore reliability practices.
- Operates over data rates to 1062.5 Mbits/s (NRZ)
- Operation at 1.3 μm or 1.55 μm wavelength
- Typical average output power options of -11 dBm, -8 dBm, -5 dBm, -2 dBm, and 0 dBm
- ECL compatible, differential inputs
- Operating temperature range of -40 °C to +85 °C
- Transmitter-disable option

Applications

- Telecommunications
 - Inter- and intraoffice SONET/ITU-T SDH
 - Subscriber loop
 - Metropolitan area networks
- High-speed data communications
 - Fibre channel (FC-0)

Description

The 1241/1243/1245-type Laser Transmitters are designed for use in transmission systems and high-speed data communication applications. Used in intraoffice and intermediate-reach applications, the transmitters are configured to operate at SONET rates up to OC-12, as well as at ITU-T Synchronous Digital Hierarchy (SDH) rates up to STM-4. Specific versions are also capable of operating up to 1062.5 Mb/s.

The transmitter meets all present Bellcore GR-253-CORE requirements, ANSI T1.117-1991 SONET single-mode, and the ITU-T G.957 and G.958 recommendations. (See Table 5 to select transmitters for the various SONET/SDH segments.)

The transmitter requires a single power supply (+5 V or -5 V) and operates over data rates of 1 Mb/s to 622 Mb/s (NRZ). Automatic power control circuitry provides constant optical output power over the operating case temperature range. The automatic power control circuitry also compensates for laser aging. The optical wavelength tolerance at 25 °C is 1310 nm. The temperature coefficient of wavelength for 1.3 μm Fabry-Perot transmitters (1241-Type) is approximately 0.4 nm/°C. The temperature coefficient of wavelength for 1.3 μm and 1.55 μm distributed-feedback (DFB) transmitters (1243/1245-Type) is approximately 0.1 nm/°C.

Transmitters are available for operation over several different temperature ranges from -40 °C to +85 °C. Manufactured in a 20-pin DIP, the transmitter consists of a hermetic, InGaAs laser and a single CMOS driver IC. The low power consumption circuit provides modulation, automatic optical output power control, and data reference. The module can be driven by either ac- or dc-coupled data in single-ended or differential configuration. (See Recommended User Interfaces section for typical connection schemes.) The laser bias and back-facet monitor currents are electrically accessible for transmitter performance monitoring. The transmitter optical output may be disabled by a logic-level input.

Functional Overview

Transmitter Circuit Description and Operation

Figure 1 shows a simplified schematic of the transmitter; pin information is listed in Table 1. The laser within the transmitter is driven by a single CMOS integrated circuit, which provides the input data signal reference level with automatic, temperature-compensated laser bias, and modulation-current control. A back-facet photo-

detector diode within the laser module provides an indication of the laser's average optical output power. The back-facet diode current is accessible as a voltage proportional to photocurrent through pins 17 and 19 on the transmitter. The back-facet diode also forms part of the feedback control circuit, which helps maintain constant output power.

The laser bias current is accessible as a dc-voltage by measuring the voltage developed across pins 2 and 4 of the transmitter. Dividing this voltage by 10 Ω will yield the value of the laser bias current. This value will change up or down in response to operating temperature, power supply voltage, data pattern, and laser aging characteristics.

Table 1. Pin Descriptions

Pin Number	Name
1	No user connection*
2	Laser bias monitor (+)†
3	No user connection*
4	Laser bias monitor (-)†
5	V _{EE}
6	V _{CC}
7	Transmitter disable
8	V _{CC}
9	V _{CC}
10	No user connection†
11	Case ground (RF ground)
12	V _{CC}
13	Case ground (RF ground)
14	V _{EE}
15	$\overline{\text{DATA}}$
16	DATA
17	Laser back-facet monitor (-)*
18	V _{CC}
19	Laser back-facet monitor (+)*
20	No user connection†

* Pins designated as no user connection should not be tied to ground or any other circuit potential.

† Laser back-facet and bias monitor functions are customer-use options that are not required for normal operations of the transmitter. They are normally used during manufacture and for diagnostics.

Functional Overview (continued)

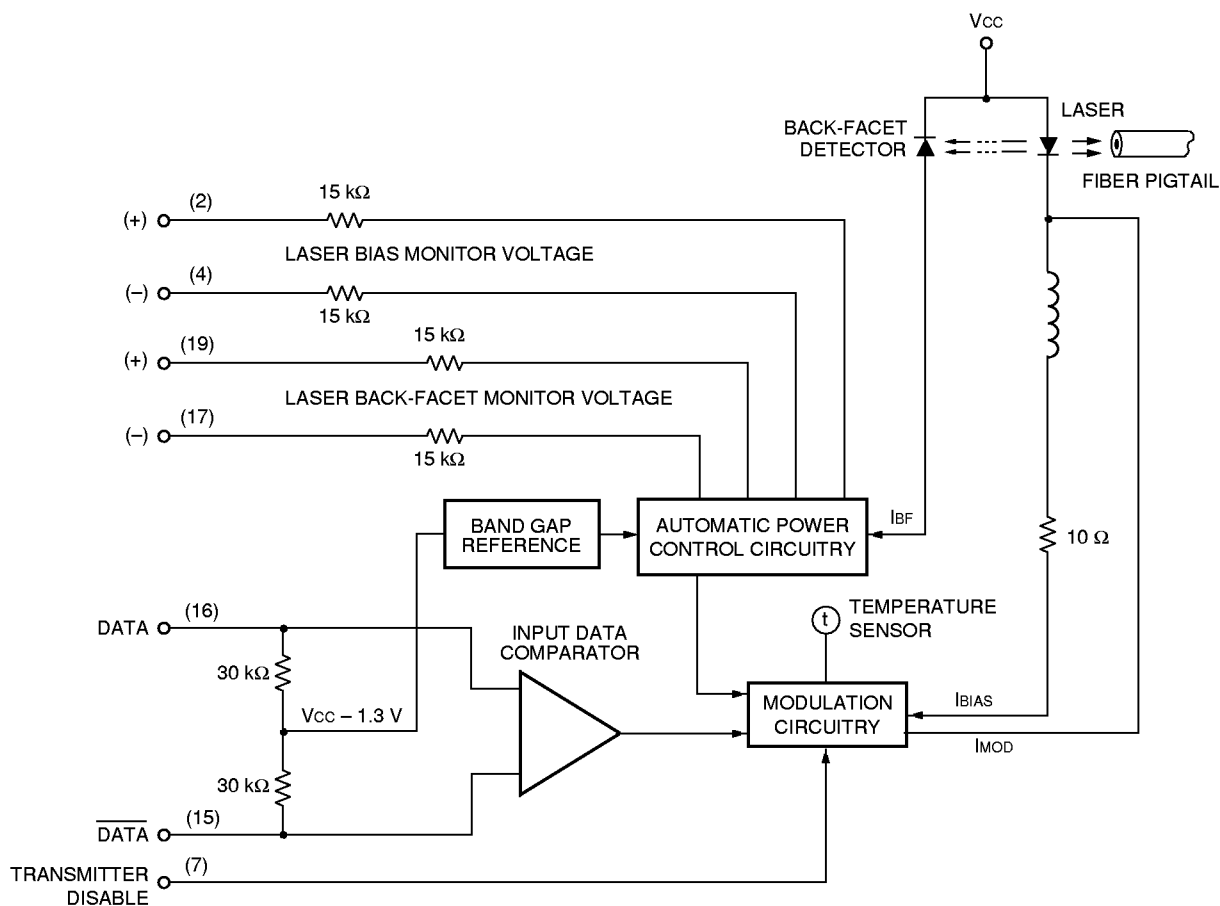

1-868(C).h

Figure 1. Simplified Transmitter Schematic Input Data

Input Data

Data enters the transmitter through a comparator. These inputs have internal pull-down resistors to a voltage reference that is 1.3 V below V_{CC} . This configuration allows the transmitter to be driven from either a single-ended or a differential input signal. Since the input is a comparator instead of a gate, the absolute input signal levels are not important when the inputs are driven differentially. When driven single-ended, however, the input signal voltage should be centered around $V_{CC} - 1.3$ V to eliminate pulse-width distortion. With a single-ended input, either input can be used and the unused input can be left as an open circuit due to the internal reference shown in Figure 1. The optical output signal will be in the same sense as the input data—an input logic high turns the laser diode on and an input logic low turns the laser diode off. However, if the negative input is used with a single-ended data

input signal, the optical signal will be the complement of the data input signal.

The differential inputs of the 1241 Gbit versions are terminated internally with 100 Ω between the data and data bar inputs.

Minimum Data Rate

Because the modulation and bias control circuitry are influenced by the input data pattern, the standard transmitter cannot be used in burst-mode type applications. For burst-mode applications, please contact your Lucent Account Manager. The minimum data rate (pseudorandom data, 50% average duty cycle) for the 1241/1243/1245-Type Transmitters is approximately 1 Mbit/s.

Functional Overview (continued)

Since most applications operate at very high data rates, high-frequency design techniques need to be used to ensure optimum performance from the transmitter and interfacing circuitry. Input signal paths should be kept as short and as straight as possible; differential signal lines should be equal in length, and controlled-impedance stripline or microstrip construction should always be used when laying out the printed-wiring board traces for the data lines. The Recommended User Interfaces section of this data sheet shows several methods of interfacing to the transmitter.

Power Supplies

The transmitter is configured for operation from either a single +5 V power supply or a single -5 V power supply. For positive power supply operation, connect V_{CC} to the +5 V power supply and connect V_{EE} to ground or circuit common. For operation from a -5 V power supply, connect V_{CC} to ground and connect V_{EE} to the -5 V power supply. Whichever option is chosen, the V_{CC} or V_{EE} connection to the transmitter should be well filtered to prevent power supply noise from interfering with transmitter operation.

Transmitter Specifications

Optical Output Power

During manufacture, the optical output power of every transmitter is tuned to the typical value specified in the data sheet for that particular transmitter code. The tuning is performed at room ambient and a power supply voltage of 5 V. The minimum and maximum values listed in the data sheet for each code group reflect the worst-case limits that the transmitter is expected to operate within over its lifetime and over allowed power supply and operating temperature range.

Every transmitter shipped receives a final test, which includes a SONET eye-mask test at either the OC-3 (STM-1) data rate of 155.52 Mbits/s, the OC-12 (STM4) data rate of 622.08 Mbits/s, or the fibre channel FC-0 data rate of 1062.5 Mbits/s. The eye-mask test is meant to examine the performance of the transmitter's output optical waveform relative to a minimum data pattern eye opening.

Connector Options

The standard optical fiber pigtail is 8 μm core single-mode fiber having a 0.036 in. (914 μm) diameter tight-buffered outer-jacket. The standard length is 39 in. \pm 4 in. (1 m \pm 10 cm) and can be terminated with either an SC or FC-PC optical connector. Other connector options may be available on special order. Contact your Lucent Account Manager for ordering information.

Handling Precautions

CAUTION: This device is susceptible to damage as a result of electrostatic discharge (ESD). Take proper precautions during both handling and testing. Follow guidelines such as JEDEC Publication No. 108-A (Dec. 1988).

Although protection circuitry is designed into the device, take proper precautions to avoid exposure to ESD. Lucent employs a human-body model (HBM) for ESD-susceptibility testing and protection-design evaluation. ESD voltage thresholds are dependent on the critical parameters used to define the model. A standard HBM (resistance = 1.5 k Ω , capacitance = 100 pF) is widely used and, therefore, can be used for comparison purposes. The HBM ESD withstand voltage established for the 1241-/1243-Type Transmitter is \pm 1000 V.

Transmitter Processing

The transmitter can withstand normal wave-soldering processes. The complete transmitter module is not hermetically sealed; therefore, it should not be immersed in or sprayed with any cleaning solution or solvents. The process cap and fiber pigtail jacket deformation temperature is 85 $^{\circ}\text{C}$. Transmitter pins can be wave-soldered at maximum temperature of 250 $^{\circ}\text{C}$ for 10 seconds.

Installation Considerations

Although the transmitter features a robust design, care should be used during handling. The optical connector should be kept free from dust, and the process cap should be kept in place as a dust cover when the device is not connected to a cable. If contamination is present on the optical connector, canned air with an extension tube can be used to remove any debris. Other cleaning procedures are identified in the technical note, *Cleaning Fiber-Optic Assemblies* (TN95-010LWP).

Absolute Maximum Ratings

Stresses in excess of the absolute maximum ratings can cause permanent damage to the device. These are absolute stress ratings only. Functional operation of the device is not implied at these or any other conditions in excess of those given in the operations sections of the data sheet. Exposure to absolute maximum ratings for extended periods can adversely affect device reliability.

Parameter	Symbol	Min	Max	Unit
Supply Voltage*	—	—	5.5	V
Operating Case Temperature Range†	T _c	-40	85	°C
Storage Case Temperature Range	T _{stg}	-40	85	°C
Lead Soldering Temperature/Time	—	—	250/10	°C/s
Relative Humidity (noncondensing)	RH	—	85	%
Minimum Fiber Bend Radius	—	1.00 (25.4)	—	in. (mm)

* With V_{EE} connected to -5 V, V_{CC} must be at 0 V; with V_{CC} connected to +5 V, V_{EE} must be at 0 V.

† Specification depends upon the code ordered. The device is capable of a cold start at -40 °C; specifications are met after a warm-up time determined by the system thermal design.

Characteristics

Minimum and maximum values specified over operating case temperature range at 50% duty cycle data signal and end of life (EOL). Typical values are measured at beginning-of-life (BOL) room temperature unless otherwise noted.

Table 2. Electrical Characteristics

Parameter	Symbol	Min	Typ	Max	Unit
Power Supply Voltage ¹	V	4.75	5.0	5.50	V
Power Supply Current Drain	I _{TOTAL}	—	30	130	mA
Input Data Voltage: ²					
Low	V _{IL}	-1.81	—	-1.47	V
High	V _{IH}	-1.16	—	-0.88	V
Input Transition Time ³	t _i	—	t/4	—	ns
Transmitter Disable Voltage ⁴	V _D	V _{CC} - 2.0	—	V _{CC}	V
Transmitter Enable Voltage	V _{EN}	V _{EE}	—	V _{EE} + 0.8	V
Output Disable Time ⁵	t _D	—	—	0.20	μs
Output Enable Time ⁶	t _{EN}	—	—	2.00	μs
Laser Bias Voltage ⁷	V _B	0.01	0.06	0.70	V
Laser Monitor Voltage (50% duty cycle) ⁸	V _{BF}	0.01	0.05	0.20	V

1. With V_{EE} connected to -5 V, V_{CC} must be at 0 V; with V_{CC} connected to +5 V, V_{EE} must be at 0 V.

2. Input measured from V_{CC} with 50 Ω load to (V_{CC} - 2 V). 10K, 10K H, and 100K ECL compatible.

3. Between 10% and 90% (50% duty cycle) where t is the bit period in ns.

4. The transmitter is normally enabled and only requires an external voltage to disable.

5. Time measured from rising edge of disable signal until optical output (laser diode) has turned off.

6. Time measured from falling edge of enable signal until optical output has stabilized at nominal output power level.

7. The laser bias current is obtained by dividing the bias voltage by the 10 Ω current-sensing resistors. (See Figure 1.) When measuring these voltages or using them in conjunction with alarm circuits, use a high-input impedance device.

8. The laser back-facet monitor voltage is a scaled output that tracks the transmitter optical output power.

Characteristics (continued)

Table 3. Optical Characteristics

Parameter	Symbol	Min	Typ	Max	Unit
Average Power Output Options ¹	P _o	See Ordering Information.			dBm
Extinction Ratio ²	r _E	10	—	—	dB
Optical Rise and Fall Times ³ :					
OC-3/STM-1	t _R , t _F	—	—	1.0	ns
OC-12/STM4	t _R , t _F	—	—	0.5	ns
1062.5 Mbits/s	t _R , t _F	—	—	0.37	ns
Center Wavelength	λ	See Ordering Information.			nm
RMS Spectral Width ⁴	Δλ	—	—	4	nm
Side-mode Suppression Ratio ⁵	SMSR	30	—	—	dB

1. Output power definitions and measurement per ITU-T Recommendation G.957 and G.958.
2. Ratio of logic 1 to logic 0 power levels.
3. Between 10% and 90% (50% duty cycle).
4. Root-mean-square spectral width accounts for modes up to and including those 20 dB down from the central mode. (Applies to 1241-Type only.)
5. Applies to 1243/1245-Type only.

Recommended User Interfaces

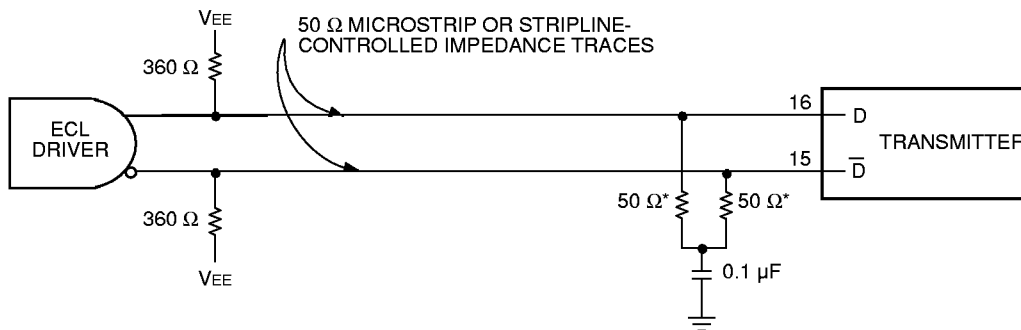

* Locate these components as close to DATA/ $\overline{\text{DATA}}$ inputs as possible.
 Note: The 1241 gigabit version does not require the external 50 Ω terminations since this termination is included inside the module.

Figure 2. dc-Coupled, Differential Input

Recommended User Interfaces (continued)

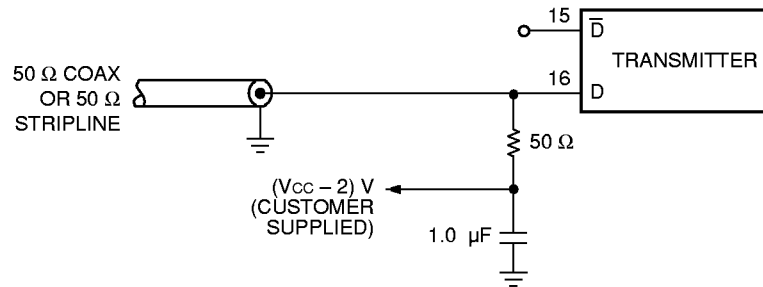

Note: Input can also be connected to $\overline{\text{DATA}}$; unused input pin remains unconnected. (622 Mbits/s and below only.)

1-497(C)

Figure 3. dc-coupled, Single-Ended Input

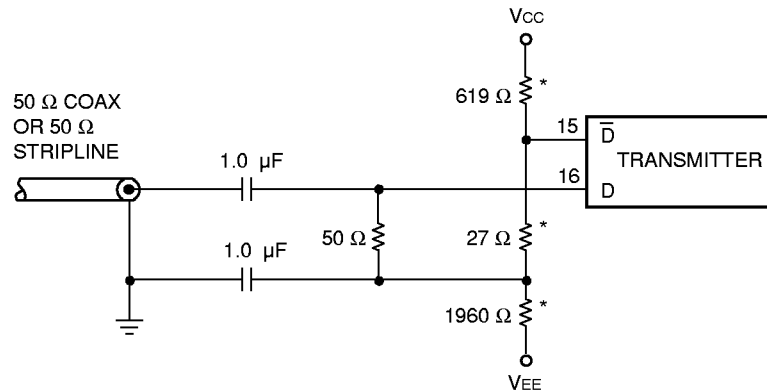

* This network introduces a slight offset between $\overline{\text{DATA}}$ and DATA , which turns the laser transmitter off when there is no data present at the inputs. (622 Mbits/s and below only.)

1-498(C)

Figure 4. ac-Coupled, Single-Ended Input

Qualification and Reliability

To help ensure high product reliability and customer satisfaction, Lucent Technologies is committed to an intensive quality program that starts in the design phase and proceeds through the manufacturing process. Optoelectronics modules are qualified to Lucent Technologies internal standards using MIL-STD-883 test methods and procedures and using sampling techniques consistent with Bellcore requirements. The 1241/1243/1245 series of transmitters have undergone an extensive and rigorous set of qualification tests. This qualification program fully meets the intent of Bellcore reliability practices TR-NWT-000468 and TA-NWT-000983. In addition, the design, development, and manufacturing facility of the Optoelectronics unit at Lucent Technologies Microelectronics Group has been certified to be in full compliance with the latest ISO-9001 Quality System Standards.

Outline Diagram

Dimensions are in inches and (millimeters). Unless otherwise noted, tolerances are ± 0.005 in (± 0.127 mm).

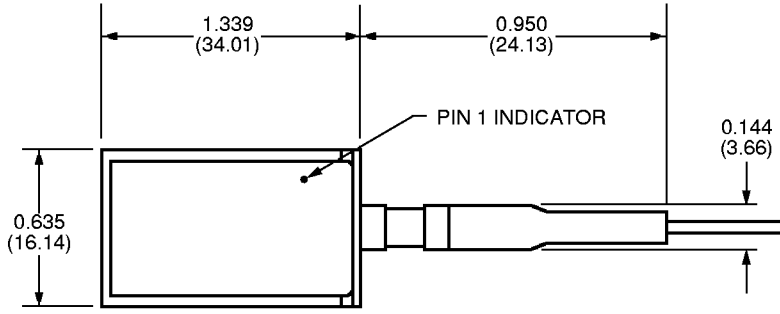

TOP VIEW

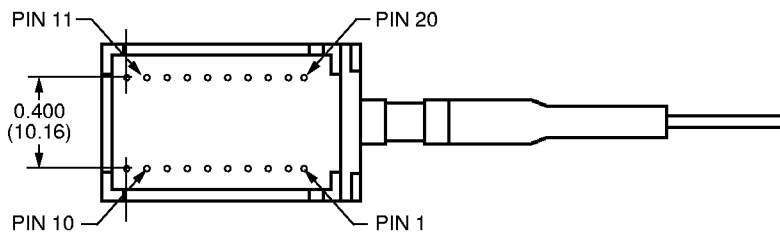
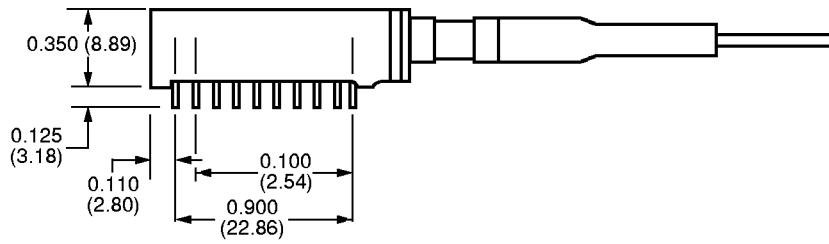

BOTTOM VIEW

1-987C).a

Laser Safety Information

Class I Laser Product

All versions of the 1241/1243/1245-Type transmitters are Class I laser products per CDRH, 21 CFR 1040 Laser Safety requirements. The 1241/1243/1245-Type transmitters have been certified with the FDA under accession number 8720009. All versions are Class I laser products per IEC 825-1:1993.

CAUTION: Use of controls, adjustments, and procedures other than those specified herein may result in hazardous laser radiation exposure.

This product complies with 21 CFR 1040.10 and 1040.11.

8.8 μm single-mode pigtail with connector

Wavelength = 1.3 μm

Maximum power = 1.6 mW

Notice

**Unterminated optical connectors may emit laser radiation.
Do not view with optical instruments.**

Table 4. Lucent Transmitters for SONET/SDH Applications

Connector Type	1.3 μm Transmitter Type*				1.55 μm Transmitter Type†	
	Short and Intermediate Reach (<2 km and ~15 km)		Long Reach ~40 km		Long Reach ~80 km	
	OC-3/STM-1	OC-12/STM-4	OC-3/STM-1	OC-12/STM-4	OC-3/STM-1	OC-12/STM-4
FC-PC	1241FAUC	1241FBUC	1243FAFD	1243FBDC	1245FAFC	1245FBDC
SC	1241CAUC	1241CBUC	1243CAFD	1243CBDC	1245CAFC	1245CBDC

* Full SONET/SDH compliance, -40 °C to +85 °C.

† Full SONET/SDH compliance, -20 °C to +70 °C.

Ordering Information

Table 5. 1241/1243/1245-Type Transmitter Ordering Information

OC-3/STM-1 Transmitter Codes										
Operating Case Temp. Range (°C)		Average Output Power (dBm)			Center Wavelength (nm)		Connector	122x Equivalent	Product Order Code	Comcode
Min	Max	Min	Typ	Max	Min	Max				
0	65	-3	0	2	1290	1330	FC-PC	1227AE	1241FADC	108123449
0	65	-3	0	2	1290	1330	SC	1227AF	1241CADC	108123480
0	65	-5	-2	0	1280	1335	FC-PC	1227YA	1241FAFC	108123357
0	65	-5	-2	0	1280	1335	SC	1227YB	1241CAFC	108123373
0	65	-8	-5	-2	1260	1360	SC	1227CA	1241CALC	108123324
0	65	-8	-5	-2	1260	1360	FC-PC	1227C	1241FALC	108123563
-20	70	-5	-2	0	1480	1580	SC	1229CB5	1245CAFC	108400409
-20	70	-5	-2	0	1480	1580	FC-PC	1229FB5	1245FAFC	108400417
-40	85	-5	-2	0	1280	1335	SC	1227YD	1243CAFD	108123423
-40	85	-5	-2	0	1280	1335	FC-PC	1227YE	1243FAFD	108123415
-40	85	-12	-8	-5	1260	1360	SC	1227FB	1241CAPC	108123282
-40	85	-12	-8	-5	1260	1360	FC-PC	1227F	1241FAPC	108123266
-40	85	-15	-11	-8	1260	1360	SC	1227HA	1241CAUC*	108123209
-40	85	-15	-11	-8	1260	1360	FC-PC	1227H	1241FAUC*	108123159
OC-12/STM-4 Transmitter Codes										
0	65	-3	0	2	1290	1330	FC-PC	1227AK	1241FBDD	108123456
0	65	-3	0	2	1290	1330	SC	1227AN	1241CBDC	108123498
0	65	-8	-5	-2	1260	1360	FC-PC	1227D	1241FBLC	108123316
-20	70	-3	0	2	1480	1580	SC	1229CA5	1245CBDC	108400391
-20	70	-3	0	2	1480	1580	FC-PC	1229FA5	1245FBDC	108400425
-40	85	-3	0	2	1280	1335	FC-PC	1229FA	1243FBDC	108123506
-40	85	-3	0	2	1280	1335	SC	1229CA	1243CBDC	108123522
-40	85	-12	-8	-5	1260	1360	FC-PC	1227G	1241FBPC	108123274
-40	85	-15	-11	-8	1260	1360	FC-PC	1227AC	1241FBUC*	108123167
-40	85	-15	-11	-8	1274	1356	SC	1227PG	1241CBU*	108123217
Fibre Channel—1062.5 Mbits/s										
10	65	-11	-8	-5	1260	1360	FC-PC	1238A	1241FCPC	108309287
10	65	-11	-8	-5	1260	1360	FC-PC	1238B	1241FCPD	108309295
10	65	-3	0	2	1290	1330	FC-PC	1238C	1241FCDC	108309279

* $\Delta\lambda$ for these codes is 2.5 nm maximum. All other 1241 type codes are 4 nm maximum.

Part Numbering for the 1241/1243/1245-Type Transmitter

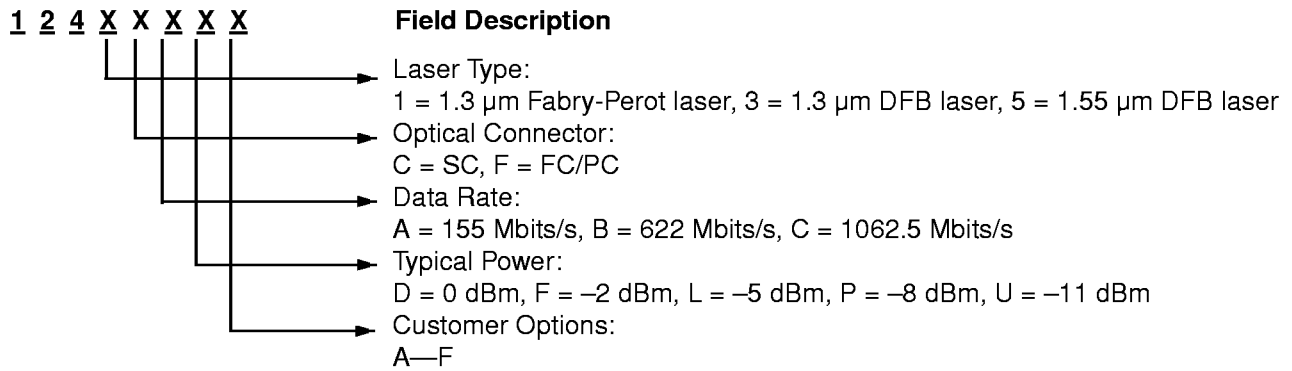

Table 6. Related Products

Description	Device Number	Document Number
155 Mbits/s and 622 Mbits/s for SONET/SDH Applications	1340-Type Pin Receiver	DS99-072LWP
155 Mbits/s and 622 Mbits/s Receivers with Clock and Data Recovery for SONET/SDH Applications	1345-Type Pin Receiver with Clock and Data Recovery	DS99-071LWP

For additional information, contact your Microelectronics Group Account Manager or the following:

INTERNET: <http://www.lucent.com/micro>, or for Optoelectronics information, <http://www.lucent.com/micro/opto>

E-MAIL: docmaster@micro.lucent.com

N. AMERICA: Microelectronics Group, Lucent Technologies Inc., 555 Union Boulevard, Room 30L-15P-BA, Allentown, PA 18103
1-800-372-2447, FAX 610-712-4106 (In CANADA: 1-800-553-2448, FAX 610-712-4106)

ASIA PACIFIC: Microelectronics Group, Lucent Technologies Singapore Pte. Ltd., 77 Science Park Drive, #03-18 Cintech III, Singapore 118256
Tel. (65) 778 8833, FAX (65) 777 7495

CHINA: Microelectronics Group, Lucent Technologies (China) Co., Ltd., A-F2, 23/F, Zao Fong Universe Building, 1800 Zhong Shan Xi Road, Shanghai 200233 P. R. China Tel. (86) 21 6440 0468, ext. 316, FAX (86) 21 6440 0652

JAPAN: Microelectronics Group, Lucent Technologies Japan Ltd., 7-18, Higashi-Gotanda 2-chome, Shinagawa-ku, Tokyo 141, Japan
Tel. (81) 3 5421 1600, FAX (81) 3 5421 1700

EUROPE: Data Requests: MICROELECTRONICS GROUP DATALINE: Tel. (44) 1189 324 299, FAX (44) 1189 328 148
Technical Inquiries: OPTOELECTRONICS MARKETING: (44) 1344 865 900 (Ascot UK)

Lucent Technologies Inc. reserves the right to make changes to the product(s) or information contained herein without notice. No liability is assumed as a result of their use or application. No rights under any patent accompany the sale of any such product(s) or information.

