

Pump Laser Modules

Key Features

330mW operating power

Epoxy free design inside the Butterfly module for long term Reliability

Fiber Bragg Grating (FBG) stabilized

Low total power consumption:
3.5W max @ 330mW

Telcordia GR-468-CORE qualified

RoHS 6/6

Applications

Low Noise High Power Erbium-Doped Fiber Amplifiers

Multi pumping architectures

Sensors

1999 PLM

365mW Kink Free, FBG Stabilized 980nm Pump Laser Module

The 1999 PLM is new generation of 980nm terrestrial pump modules powered by in-house chip technology which contains a new high power laser chip internally developed and fully qualified. Low Profile, epoxy-free, 14-pin butterfly modules are available with an operating power up to 330mW. The wavelength is “locked” utilizing a fiber bragg grating (FBG) located in a Single Mode HI1060 fiber (SMF) pigtail. The module meets Telcordia™ GR-468-Core for hermetic 980nm pump modules.

These modules provide excellent stability and wide dynamic range due to their specific design.

They incorporate a thermoelectric cooler (TEC), a precision NTC thermistor and a back-facet monitoring photodiode.

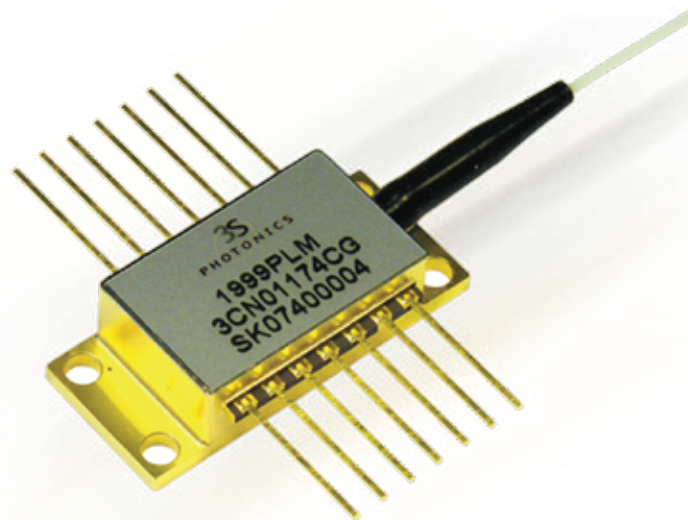

For more info

Please contact us at:

North America: **514.748.4848**
888.922.1044

Europe & Asia: **+33 (0) 1 69 80 58 33**
or via e-mail at sales@3spgroup.com

1999 PLM

365mW Kink Free, FBG Stabilized 980nm Pump Laser Module



ELECTRO-OPTICAL CHARACTERISTICS

The following parameters are specified BOL for $T_{submount} = 25^{\circ}\text{C} \pm 1^{\circ}\text{C}$, $V_{BFM} = -5\text{V}$, -50dB max back-reflection and $T_{case} = -5^{\circ}\text{C}$ to 75°C unless otherwise stated.

Parameters	Conditions	Symbol	Min	Typ	Max	Unit	
PUMP LASER							
Threshold current	Note 1	I_{th}	-	45	60	mA	
Nominal operating power		P_{nom}	250	-	-	mW	
Kink free power	Note 2	P_{kink}	$1.1 \times P_{nom}$	-	-	mW	
Forward current @ P_{nom}	Note 3	I_{nom}	$P_{nom} = 150\text{mW}$	-	260	290	mA
			$P_{nom} = 200\text{mW}$	-	330	365	
			$P_{nom} = 250\text{mW}$	-	400	440	
			$P_{nom} = 300\text{mW}$	-	470	515	
			$P_{nom} = 330\text{mW}$	-	520	570	
Forward voltage	@330mW	V_{nom}	-	1.8	2.0	V	
Peak wavelength tolerance	@ $T_{case} = T_{FBG} = 25^{\circ}\text{C}$	$\Delta \lambda_p$		-	± 0.5	nm	
Wavelength tuning vs temperature ($T_{grating} = -5$ to 75°C)	$0.1 \times P_{nom}$ to P_{nom}	$\Delta \lambda_p / \Delta T$	-	0.01	0.02	nm/ $^{\circ}\text{C}$	
Spectral width @-3dB	$0.1 \times P_{nom}$ to P_{nom}	$\Delta \lambda_{FWHM}$	-	-	1.0	nm	
Power in band	Note 4	P_{band}	90	-	-	%	
Optical power stability	Peak to peak, 10Hz-50kHz, P_{nom}	ΔP_f	-	<1	2	%	
MONITOR DIODE							
Responsivity		I_{BFM} / P	0.5	-	10	$\mu\text{A}/\text{mW}$	
Dark current	$V_r = 5\text{V}$	I_{BFM_dark}	-	50	100	nA	
THERMO-ELECTRICAL COOLER							
Cooling capacity		ΔT_{TEC}	50	-	-	$^{\circ}\text{C}$	
TEC voltage (EOL)	$T_{case} = 75^{\circ}\text{C}$, $1.1 \times I_{nom}$	V_{TEC_EOL}	-	-	2.1	V	
TEC current (EOL)		I_{TEC_EOL}	-	-	1.4	A	
TEC Power consumption		P_{TEC}	-	-	2.9	W	
THERMISTOR							
Resistance	25°C	R_{th}	9.5	10	10.5	k Ω	
Constant		B	3600	-	4200	K	

Note 1: I_{th} is the intersection point with the x-axis of a linear fit of the P(I) curve between 15 and 50mW

Note 2: A kink is detected when the local slope, dP/dI , is below S_{min} or above S_{max} .

S_{min} is defined as $0.5 \times S_{avg}$ and S_{max} is defined as $1.5 \times S_{avg}$

S_{avg} is the slope of a linear fit of the P(I) curve between 50 and 150mW.

Note 3: EOL forward current $I(EOL) = 1.1 \times I(BOL)$

Note 4: P_{band} is defined as the power within the band $\lambda_p \pm 1.5\text{nm}$ vs the total output power

1999 PLM

**365mW Kink Free, FBG
Stabilized 980nm Pump
Laser Module**



3

Absolute Maximum Ratings

Exposing this device to stresses and conditions above those listed in this section could cause permanent damage and affect reliability. The device is not meant to operate outside the operational limits described in previous section at any length of time.

Parameter Conditions	Symbol	Min	Max	Unit
Storage temperature (2000h)	T_{stg}	-40	85	°C
Operating temperature ($T_{submount} = 25^{\circ}\text{C}$)	T_{op}	-5	75	°C
Lead soldering temperature (10s maximum)		-	260	°C
LD forward drive current	I_{f_max}	-	660	mA
LD reverse voltage	V_{r_max}	-	2	V
PD reverse voltage	V_{PD_max}	-	15	V
PD forward current	I_{PD_max}	-	10	mA
TEC voltage	V_{TEC_max}	-	3.3	V
TEC current	I_{TEC_max}	-	2.4	A
ESD* damage	V_{ESD}	-	1000	V
Mounting torque		-	150	mN.m
Fiber bend radius		25	-	mm
Axial pull force (1x 1min)		-	5	N

* Human Body Model, C= 100pF, R= 1.5Ω

Fiber Pigtail Characteristics

Parameters	Note	Min	Typ	Max	Unit
Fiber type			HI1060™ or equivalent		
Coating diameter	(except along grating)	230	250	270	μm
FBG recoat diameter		-	-	400	μm
FBG position	Module to center of FBG		2		m
Loose tube buffer diameter		885	-	915	μm
Fiber proof test level		100			kpsi
Grating proof test level		150			kpsi
Pigtail termination	Bare fiber				

1999 PLM

365mW Kink Free, FBG Stabilized 980nm Pump Laser Module



Mechanical Details

Dimensions are in mm.

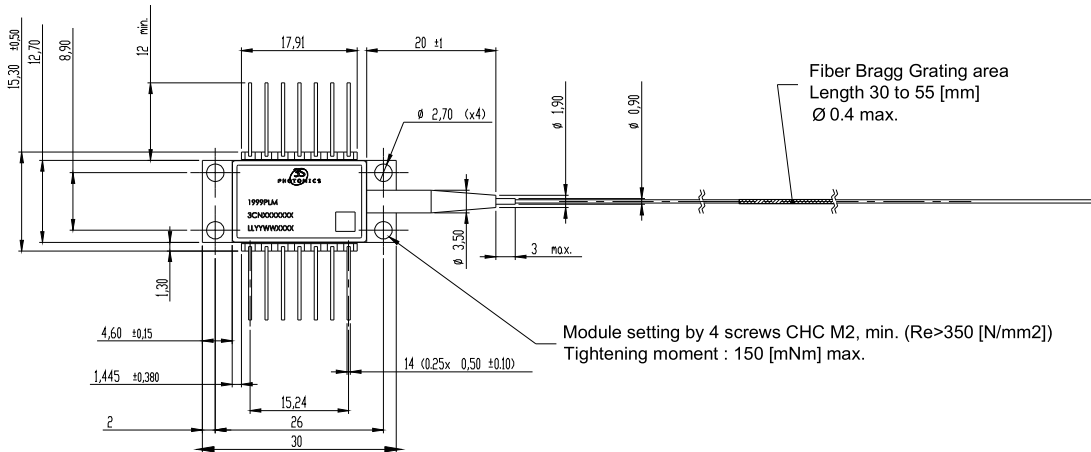
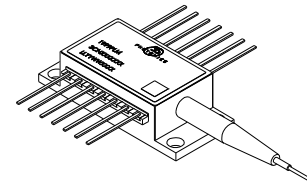
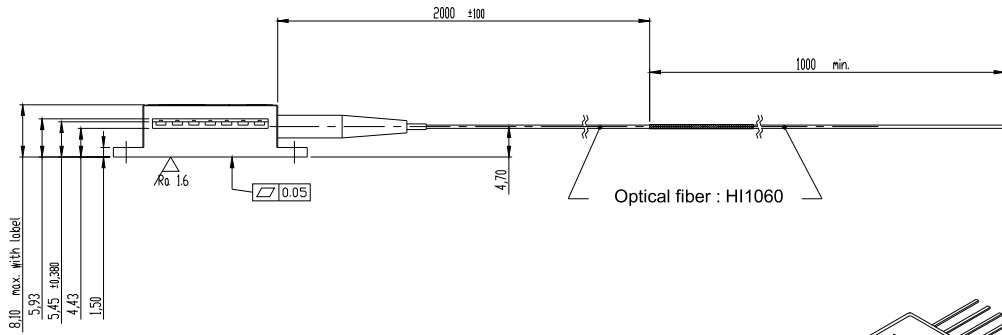

Pin Assignment

N°	Description	N°	Description
1	TEC (+)	8	No connect
2	Thermistor	9	No connect
3	Monitor PD Anode	10	Laser Anode (+)
4	Monitor PD Cathode	11	Laser Cathode (-)
5	Thermistor	12	No connect
6	No connect	13	Ground
7	No connect	14	TEC (-)

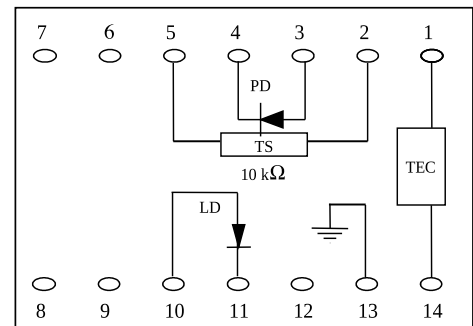

Totally floating pin-out.

1999 PLM

365mW Kink Free, FBG Stabilized 980nm Pump Laser Module



5

Laser Safety Information

This laser module emits invisible light. Take appropriate precautions to prevent undue exposure to naked eye when module is in operation.

This product is classified Class 4 Laser Product according to IEC-60825-1.

Handling

This product is sensitive to modules. Handle the module by its package only, never hold it by its pigtail.

Care should be taken to avoid supply transient currents and voltages. Drive voltage above the maximum specified in absolute maximum rating section electrostatic discharge and should not be handled except at a static free workstation.

Take precautions to prevent ESD ; use wrist straps, grounded work surfaces and recognized anti-static techniques when handling the product may cause permanent damage to the device.



Ordering Information

1999 PLM pump product family – other wavelengths are available upon request.

Nominal Power (mW)	$\lambda_p = 974.5\text{nm}$	$\lambda_p = 976.0\text{nm}$
	T = 25 °C	T = 25 °C
	Part Number	Part Number
150	3CN 01174 AL	3CN 01343 AL
200	3CN 01174 BA	3CN 01343 BA
250	3CN 01174 BL	3CN 01343 BL
300	3CN 01174 CA	3CN 01343 CA
330	3CN 01174 CG	3CN 01343 CG

Revised March 2012

Please note: information in this document is typical and must be specifically confirmed in writing by your supplier before it becomes applicable to any order or contract.

Information is subject to change without notice.

©2011 3S PHOTONICS S.A.S.

ORDERING INFO

Please contact your Sales Manager. 3SPGroup can also develop custom products to meet a wide range of technical requirements.

3SPGroup

North America: 514.748.4848

888.922.1044

Europe and Asia: +33 (0)1 69 80 58 33

www.3spgroup.com • sales@3spgroup.com