

SPACE-PHY +5V Dual MIL-STD-1553 Transceiver/Transformer Device



Data Sheet

Models: BU-67402F0GHL



SPACE-PHY is a completely integrated MIL-STD-1553 physical layer in a single package, including dual transceivers and transformers, suitable for connection to IP incorporated in an FPGA or custom MIL-STD-1553 protocol ASIC.

Applications

- Launch Vehicles
- Military Satellites
- Research Satellites
- International Space Station
- Commercial Telecommunication Satellite

Custom Design Capability - DDC can customize designs for all cards, ranging from simple modifications of standard products to fully customized solutions for commercial, military, aerospace, and industrial applications.

For more information: www.ddc-web.com/BU-67402F

DDC's Data Networking Solutions

MIL-STD-1553 | ARINC 429 | Fibre Channel | AFDX®/ARINC 664

As the leading global supplier of data bus components, cards, and software solutions for the military, commercial, and aerospace markets, DDC's data bus networking solutions encompass the full range of data interface protocols to support the real-time processing demands of field-critical data networking between military vehicles, systems, and subsystems. These products, along with our traditional MIL-STD-1553 solutions, represent a wide and flexible array of performance and cost requirements, enabling DDC to support multi-generational programs.

DDC has developed its line of high-speed Fibre Channel and Extended 1553 products to support the real-time processing of field-critical data networking between sensors, compute nodes, data storage displays, and weapons for air, sea, and ground military vehicles.

Whether employed in increased bandwidth, high-speed serial communications, or traditional avionics and ground support applications, DDC's data solutions fulfill the expanse of military requirements including reliability, determinism, low CPU utilization, real-time performance, and ruggedness within harsh environments. Our use of in-house intellectual property ensures superior multi-generational support, independent of the life cycles of commercial devices. Moreover, we maintain software compatibility between product generations to protect our customers' investments in software development, system testing, and end-product qualification.

MIL-STD-1553

DDC provides an assortment of quality MIL-STD-1553 commercial, military, and COTS grade cards and components to meet your data conversion and data interface needs. DDC supplies MIL-STD-1553 board level products in a variety of form factors including AMC, USB, PCI, cPCI, PCI-104, PCI-Express PCMCIA, PMC, XMC, PC/104, PC/104-Plus, VME/VXI, and ISAbus cards. Our 1553 data bus board solutions are integral elements of military, aerospace, and industrial applications. Our extensive line of military and space grade components provide MIL-STD-1553 interface solutions for microprocessors, PCI buses, and simple systems. Our 1553 data bus solutions are designed into a global network of aircraft, helicopter, and missile programs.

ARINC 429

DDC also has a wide assortment of quality ARINC-429 commercial, military, and COTS grade cards and components, which will meet your data conversion and data interface needs. DDC supplies ARINC-429 board level products in a variety of form factors including AMC, USB, PCI, PMC, PCI-104, PCI-Express, PC/104 Plus, and PCMCIA boards. DDC's ARINC 429 components ensure the accurate and reliable transfer of flight-critical data. Our 429 interfaces support data bus development, validation, and the transfer of flight-critical data aboard commercial aerospace platforms.

Fibre Channel

DDC has developed its line of high-speed Fibre Channel network access controllers and switches to support the real-time processing demands of field-critical data networking between sensors, computer nodes, data storage, displays, and weapons, for air, sea, and ground military vehicles. Fibre Channel's architecture is optimized to meet the performance, reliability, and demanding environmental requirements of embedded, real time, military applications, and designed to endure the multi-decade life cycle demands of military/aerospace programs.

AFDX®/ARINC 664

DDC provides powerful, field-proven AFDX®/ARINC 664 solutions for test, simulation, and system integration. These cards support both Airbus and Boeing AFDX protocol.



SPACE-PHY +5V DUAL MIL-STD-1553 TRANSCEIVER/TRANSFORMER DEVICE

BU-67402 DATA SHEET

The information provided in this Data Sheet is believed to be accurate; however, no responsibility is assumed by Data Device Corporation for its use, and no license or rights are granted by implication or otherwise connection therewith.

Specifications are subject to change without notice.
Please visit our Web site at <http://www.ddc-web.com/> for the latest information.

All rights reserved. No part of this Data Sheet may be reproduced or transmitted in any form or by any mean, electronic, mechanical photocopying recording, or otherwise, without the prior written permission of Data Device Corporation.

105 Wilbur Place
Bohemia, New York 11716-2426
Tel: (631) 567-5600, Fax: (631) 567-7358
World Wide Web - <http://www.ddc-web.com>

WARNING ITAR CONTROLLED PRODUCT – The product(s) referenced in this data sheet and certain related technical data are subject to the U.S. Department of State International Traffic in Arms Regulations (ITAR) 22 CFR 120-130 and may not be exported without the appropriate prior authorization from the Directorate of Defense Trade Controls, United States Department of State. This datasheet includes only basic marketing information on the function of the product and therefor is not considered technical data as defined in 22 CFR 120.10.

For Technical Support - 1-800-DDC-5757 ext. 7771
United Kingdom - Tel: +44-(0)1635-811140, Fax: +44-(0)1635-32264
France - Tel: +33-(0)1-41-16-3424, Fax: +33-(0)1-41-16-3425
Germany - Tel: +49-(0)89-15 00 12-11, Fax: +49-(0)89-15 00 12-22
Japan - Tel: +81-(0)3-3814-7688, Fax: +81-(0)3-3814-7689
Asia - Tel: +65-6489-4801



© 2013 Data Device Corp.

RECORD OF CHANGE

Revision	Date	Pages	Description
Rev Pre A	6/2013	All	Preliminary Release
Rev A	8/2013	All	Initial Release
Rev B	8/2013	5	Update to figure 2

1 PREFACE.....1
1.1 Text Usage.....1
1.2 Special Handling and Cautions1
1.3 Trademarks.....1
1.4 What is included in this data sheet?1
1.5 Technical Support2

2 OVERVIEW3
2.1 Features.....3

3 INTRODUCTION8
3.1 TRANSMIT OPERATING MODE8
3.2 RECEIVER OPERATING MODE8
3.3 WAVEFORMS.....9
3.4 1553 BUS INTERFACE AND LAYOUT CONSIDERATIONS9
3.5 Radiation Tolerance10
3.6 High-Rel Screening11

4 ORDERING INFORMATION17

Figure 1. BU-67402 SPACE-PHY Transceiver/Transformer.....4
Figure 2. BU-67402 Block Diagram5
Figure 3. Waveforms for Harris Type Encoder/Decoder9
Figure 4. BU-67402 Interface to a MIL-STD-1553 Bus.....10
Figure 5. BU-67402 Mechanical Outline – SPACE-PHY 36-pin Flat Package13
Figure 6. BU-67402 Mechanical Outline – SPACE-PHY 36-pin Gull Wing Package14

Table 1. BU-67402 Specification Table5
Table 2. BU-67402 Radiation Specifications10
Table 3. High Reliability Screening Options.....11
Table 4. BU-67402 Pad Signal Descriptions.....14

1 PREFACE

This data sheet uses typographical conventions to assist the reader in understanding the content. This section will define the text formatting used in the rest of the manual

1.1 Text Usage

- **BOLD**—indicates important information and table, figure, and chapter references.
- ***BOLD ITALIC***—designates DDC Part Numbers.
- Courier New—indicates code examples.
- <...> - indicates user-entered text or commands.

1.2 Special Handling and Cautions

The **BU-67402** is a state-of-the-art component, and proper care should be used to ensure that the device will not be damaged by Electrical Static Discharge (ESD), physical shock, or improper power surges and that precautions are taken to avoid electrocution.



Warnings: Turn off power to the computer hardware and unplug from wall.

NEVER insert or remove card with power turned on.

Ensure that standard ESD precautions are followed. As a minimum, one hand should be grounded to the power supply in order to equalize the static potential.

Do not store disks in environments exposed to excessive heat, magnetic fields or radiation.

1.3 Trademarks

All trademarks are the property of their respective owners.

1.4 What is included in this data sheet?

This data sheet contains a complete description of hardware installation and use.

1.5 Technical Support

In the event that problems arise beyond the scope of this manual, you can contact DDC by the following:

US Toll Free Technical Support:
1-800-DDC-5757, ext. 7771

Outside of the US Technical Support:
1-631-567-5600, ext. 7771

Fax:
1-631-567-5758 to the attention of DATA BUS Applications

DDC Website:
www.ddc-web.com/ContactUs/TechSupport.aspx

Please note that the latest revisions of Software and Documentation are available for download at DDC's Web Site, www.ddc-web.com.

2 OVERVIEW

The **BU-67402** is a radiation-hardened MIL-STD-1553 dual transceiver with integrated isolation transformers that operates from a +5V power supply voltage. It operates with Harris type encoder/decoders and supports both transformer and direct-coupled operation.

The receiver section of the **BU-67402** accepts Manchester II data from a MIL-STD-1553 Data Bus or stub and produces TTL level signals at its outputs:

RX_DATA_OUT and $\overline{\text{RX_DATA_OUT}}$. These outputs represent positive and negative excursions of the input data signals beyond an internally fixed threshold level. An external STROBE input enables or disables the receiver's outputs.

The transmitter section accepts bipolar TTL signal data at its TX_DATA_IN and $\overline{\text{TX_DATA_IN}}$ inputs and produces Manchester II data at the TXOUT and $\overline{\text{TXOUT}}$ outputs.

An external input, TX_INHIBIT, takes priority over the transmitter inputs and disables the respective transmitter when asserted to logic "1". The small size, 5V power supply voltage, and integrated transformers simplify engineering design, making it an excellent choice for interfacing with any MIL-STD-1553 system.

2.1 Features

- Dual-Redundant, Side-by-Side, MIL-STD-1553 Transceiver/Transformer Combo
- Compact Ceramic Flatpack Package
 - 1 in. x 1 in. x 0.25 in. (25.4 mm x 25.44 mm x 6.35 mm)
- Radiation Specifications
 - Total Dose: 100krads
 - Latchup Immunity: 85.4 MeV-cm²/mg
 - Contact Factory for Radiation Reports and Test Conditions
- Dual Tap Secondaries
 - Secondaries' Center Taps Brought Out
- DSCC MIL-PRF-38534 Class H or K Certified

Applications Include:

- Launch Vehicles

- Military Satellites
- Research Satellites
- International Space Station
- Commercial Telecommunication Satellite

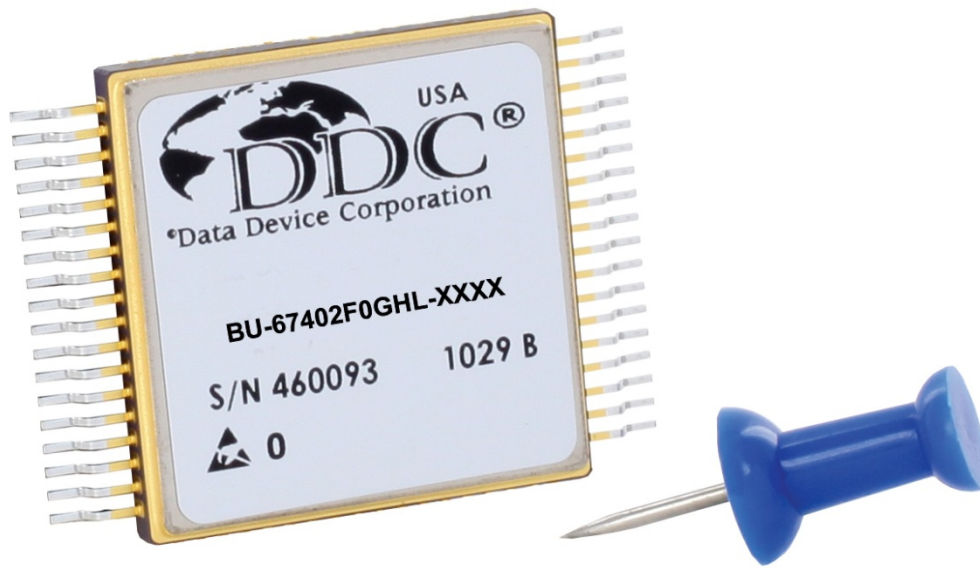

Figure 1. BU-67402 SPACE-PHY Transceiver/Transformer

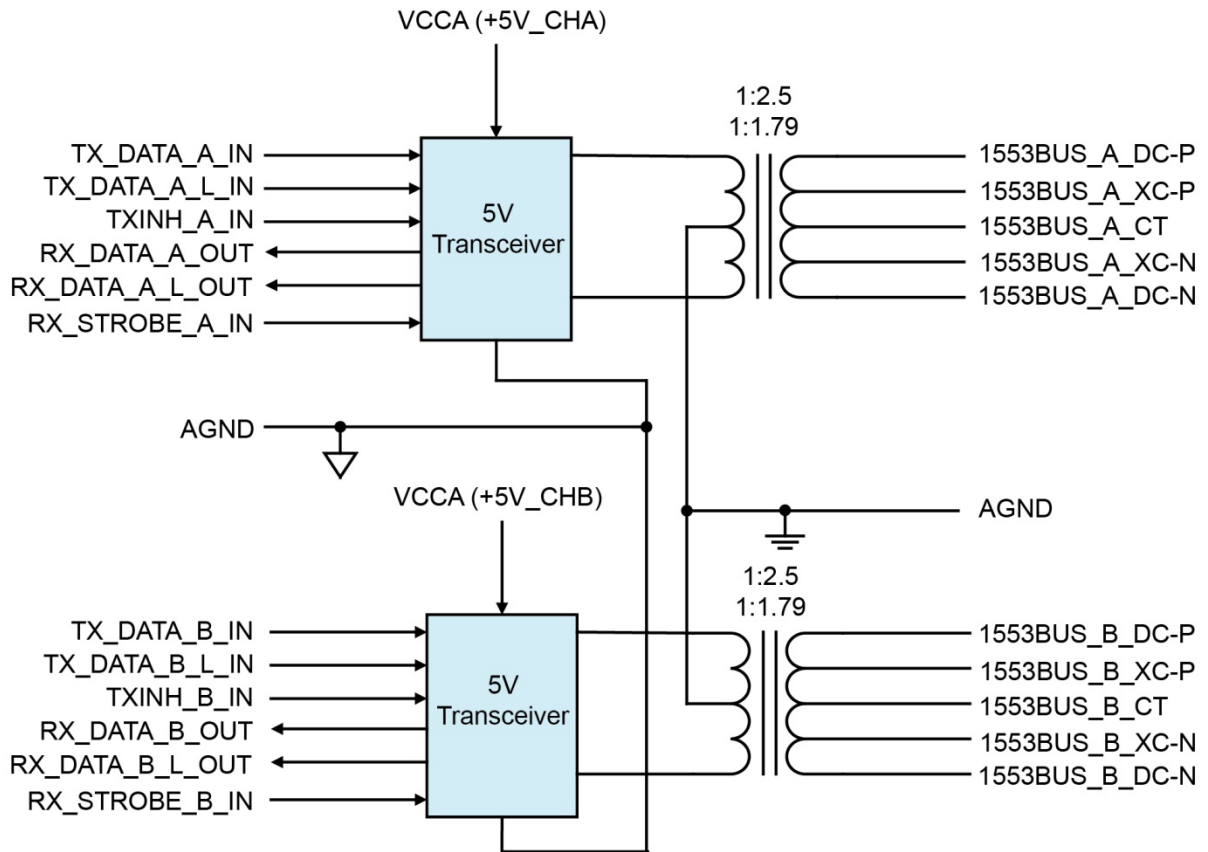

Figure 2. BU-67402 Block Diagram

Table 1. BU-67402 Specification Table				
PARAMETER	MIN	TYP	MAX	UNITS
ABSOLUTE MAXIMUM RATINGS				
Supply Voltage				
+5 V (VCCA, VCCB)	-0.3	5.0	7.0	Vdc
Receiver				
Input Voltage (Differential, Transformer-Coupled)			38	Vp-p
Input Voltage (Differential, Direct-Coupled)			53	Vp-p
Logic				
Voltage Input Range	-0.3		Vcc + 0.3	V
POWER SUPPLY REQUIREMENTS				
Voltages/Tolerances				
+5V	4.75	5.0	5.25	V
Current Drain (Notes 9, 10)				
• Idle		80	100	mA
• 25% Transmitter Duty Cycle (1 Ch. Transmitting)		199	229	mA
• 50% Transmitter Duty Cycle (1 Ch. Transmitting)		286	348	mA
• 100% Transmitter Duty Cycle (1 Ch. Transmitting)		455	535	mA

Table 1. BU-67402 Specification Table				
PARAMETER	MIN	TYP	MAX	UNITS
POWER DISSIPATION				
V_{cc} = +5V (Note 9)				
• Idle		0.40	0.50	W
• 25% Transmitter Duty Cycle (1 Ch. Transmitting)		0.66	0.81	W
• 75% Transmitter Duty Cycle (1 Ch. Transmitting)		0.75	1.06	W
• 100% Transmitter Duty Cycle (1 Ch. Transmitting)		0.92	1.32	W
RECEIVER				
Differential Input Impedance, Transformer-Coupled (Notes 1 – 6)	1.0			kΩ
Differential Input Impedance, Direct-Coupled (Notes 1 – 6)	2.0			kΩ
Threshold Voltage, Transformer-Coupled, Measured on Stub (Note 7)	0.200		0.860	V _{p-p}
Threshold Voltage, Direct-Coupled, Measured on Stub (Note 7)	0.280		1.200	V _{p-p}
Common-Mode Voltage (Note 8)	-10		10	V _{peak}
TRANSMITTER				
Differential Output Voltage				
• Direct Coupled Across 35Ω, Measured on Bus	6	7	9	V _{p-p}
• Transformer Coupled Across 70Ω, Measured on Stub	18	20	27	V _{p-p}
Output Noise, Differential (Direct Coupled)			10	mV _{p-p} , diff
Output Offset Voltage, Transformer Coupled Across 70Ω	-250		+250	mV _{p-p} , diff
Rise/Fall Time	100	150	300	ns
LOGIC				
V _{IH}	2.0			V
V _{IL}			0.8	V
I _{IH} (RX_STROBE)	-10		10	μA
I _{IL} (RX_STROBE)	-100		-20	μA
I _{IH} (TX_DATA_IN, TX_DATA_IN [¯] , TX_INHIBIT)	20		100	μA
I _{IL} (TX_DATA_IN, TX_DATA_IN [¯] , TX_INHIBIT)	-10		+10	μA
V _{OH} (V _{cc} = 4.75V, I _{OH} = max)	2.4			V
V _{OL} (V _{cc} = 4.75V, I _{OL} = min)			0.4	V
I _{OL}	3.4			mA
I _{OH}			-3.4	mA
THERMAL				
Thermal Resistance, Junction-to-Case (θ _{jc})		7.8	9.0	°C/W
Operating Case Temperature				
BU-67402X0GXL-1XX	-55		+125	°C
Storage Temperature	-65		+150	°C
Lead Temperature (soldering, 10 sec.)			+300	°C

Table 1. BU-67402 Specification Table				
PARAMETER	MIN	TYP	MAX	UNITS
PHYSICAL CHARACTERISTICS				
Package Body Size 36-Lead Flatpack		1.01 x 1.01 x 0.25 (25.654 x 25.654 x 6.35)		in. (mm)
Weight		0.353 (10.0)		oz. (g)
<p>Table 1 Notes: Notes 1 through 6 are applicable to the Receiver Differential Resistance and Differential Capacitance specifications:</p> <ol style="list-style-type: none"> Specifications include transmitter, receiver, and transformer. Impedance parameters are specified directly between pins 1553BUS_A(B)_XC-P and 1553BUS_A(B)_XC-N or 1553BUS_A(B)_DC-P and 1553BUS_A(B)_DC-N. It is assumed that all power and ground inputs to the package are connected for the impedance measurement. The 1553BUS_A(B)_CT transformer secondary connections are left unconnected for this measurement. The specifications are applicable for both un-powered and powered conditions. The specifications assume a 2-volt rms balanced differential, sinusoidal input. The applicable frequency range is 75 kHz to 1 MHz. Minimum impedance is guaranteed over the operating range, but not tested. The Threshold Level, as referred to in this specification, is meant to be the maximum peak-to-peak voltage (measured across the data bus or stub) that can be applied to the receiver's input without causing the output to change from the OFF state. Assumes a common mode voltage within the frequency range of DC to 2 MHz, applied to the 1553BUS_A(B)_DC(XC) pins, and referenced to ANALOG GROUND. Current drain and power dissipation specifications are preliminary and subject to change. Power dissipation of the transceiver is defined as the total power into the device minus the power dissipated in the load. When transmitting, the peak supply current can be as high as 800mA. 				

3 INTRODUCTION

The **BU-67402** is a radiation-hardened dual transmitter and receiver with integrated isolation transformers packaged in a 36-lead ceramic flatpack package. It is directly compatible with Harris type encoder/decoders and has internal (factory preset) threshold levels. The transceiver/transformer only requires +5V power and conforms to MIL-STD-1553A/B.

Figure 4 illustrates the connection between a **BU-67402** transceiver/transformer and a MIL-STD-1553 data bus. It can be either direct coupled (short stub) or transformer coupled (long stub) to the 1553 data bus. The transformer secondary center tap connections are also brought out. These pins may be left unconnected, or may be connected to reduce common mode voltages for mitigating against ESD, lightning, and/or HIRF.

3.1 Transmit Operating Mode

The transmitter section accepts encoded TTL data and converts it to bi-phase Manchester II form using a waveshaping network and driver circuits. The driver outputs TXOUT and $\overline{\text{TXOUT}}$ are transformer isolated from the Data Bus.

The transmitter output terminals can be put into a high impedance state by setting TX_INHIBIT high, or asserting TX_DATA_IN and $\overline{\text{TX_DATA_IN}}$ to the same logic level.

3.2 Receiver Operating Mode

The receiver section accepts data from a MIL-STD-1553 Data Bus when coupled to the Data Bus as shown in Figure 4. This data is converted to TTL levels and provided as RX_DATA_OUT and $\overline{\text{RX_DATA_OUT}}$.

When STROBE is high, data passes through the receiver to RX_DATA_OUT and $\overline{\text{RX_DATA_OUT}}$. Applying a low to STROBE disables the receiver output terminals.

As illustrated in Figure 3, the receiver in the **BU-67402** provides compatibility with Harris type decoders.

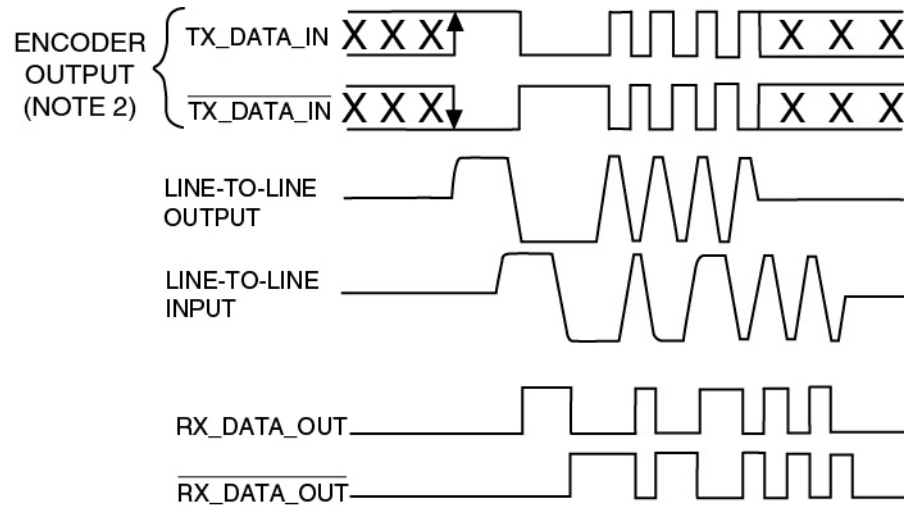

- Notes:
- (1) TX_DATA_IN and RX_DATA_OUT are TTL signals.
 - (2) TX_DATA_IN inputs must be at the same logic level when not transmitting.
 - (3) LINE-TO-LINE voltage is measured on the Data Bus.

Figure 3. Waveforms for Harris Type Encoder/Decoder

3.3 Waveforms

Figure 3 illustrates the **BU-67402** with Harris type decoder interface. Note that the TX_DATA_IN and TX_DATA_IN inputs must be complementary waveforms with a 50% duty cycle.

3.4 1553 Bus Interface and Layout Considerations

Figure 4 illustrates the interface between the **BU-67402** and a MIL-STD-1553 bus. Connections for both direct (short stub) and transformer (long stub) coupling, as well as the peak-to-peak voltage levels at various points (when transmitting), are indicated in the diagram.

It is recommended that a 10 μ F low inductance capacitor (tantalum or ceramic) be placed as close as possible to the transceiver power inputs of the **BU-67402** for each transceiver channel.

It is also recommended that a 0.01 μ F ceramic capacitor be mounted as close as possible and with the shortest leads to each transceiver power input of the **BU-67402**.

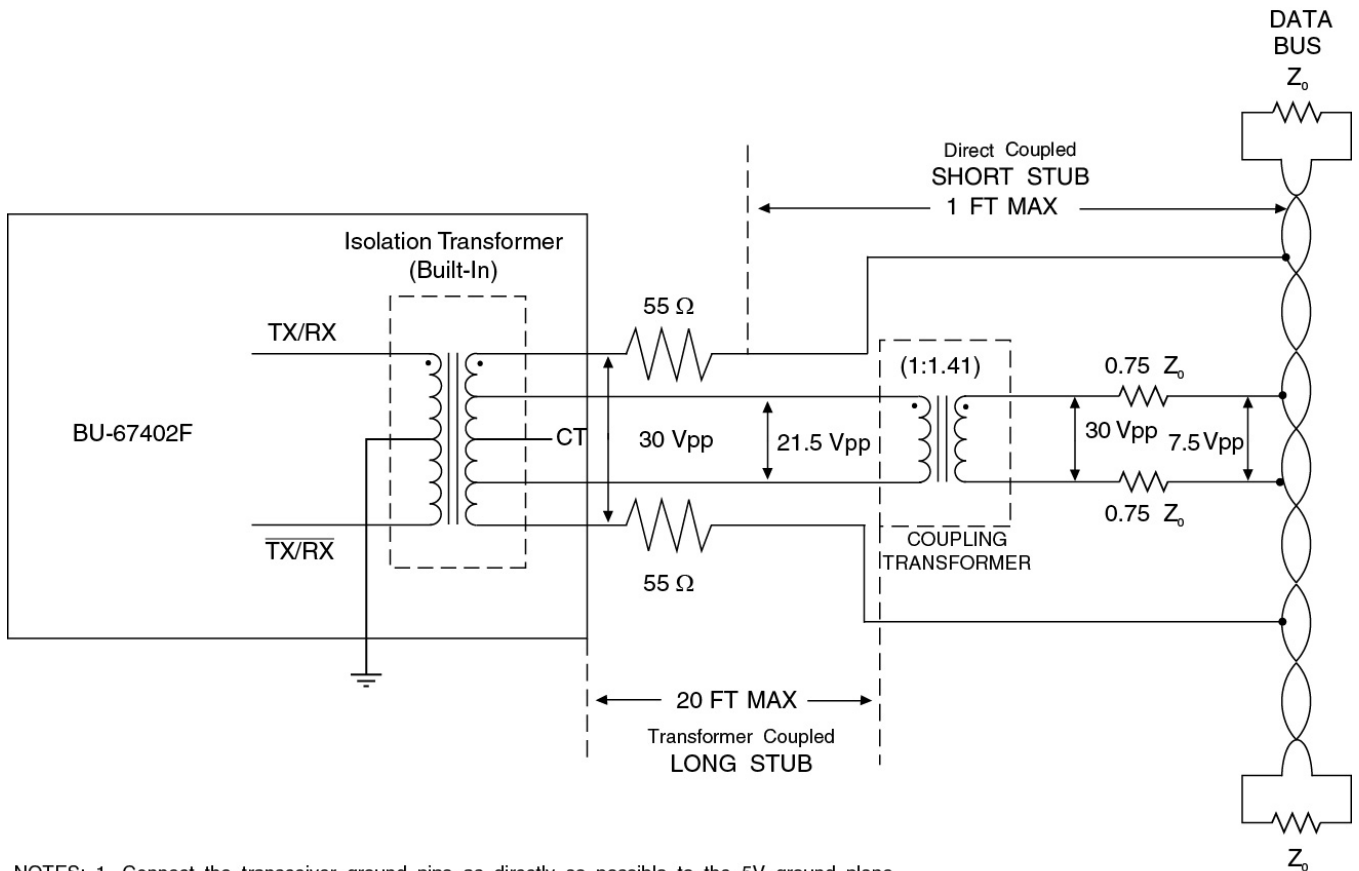

NOTES: 1. Connect the transceiver ground pins as directly as possible to the 5V ground plane.
 2. $Z_o = 70$ to 85 Ohms.

Figure 4. BU-67402 Interface to a MIL-STD-1553 Bus

3.5 Radiation Tolerance

The **BU-67402** utilizes BiCMOS analog transceivers and has a total gamma dose immunity of 1×10^5 Rad and an SEU threshold of $85.4 \text{ MeV-cm}^2/\text{mg}$.

Table 2. BU-67402 Radiation Specifications				
PARAMETER	MIN	TYP	MAX	UNITS
Total Dose	1×10^5			Rad
Single Event Latchup Immunity	8.54×10^7			$\text{eV-cm}^2/\text{mg}$

Radiation parameters specified in this data sheet are derived from initial qualification testing by DDC. These devices have not been evaluated for compliance to the RHA requirements stipulated in MIL-PRF-38534, Appendix G.

3.6 High-Rel Screening

DDC is committed to the design and manufacture of hybrids and transformers with enhanced processing and screening for spaceborne applications and other systems requiring the highest levels of reliability. These platforms include launch vehicles, satellites, and the International Space Station.

DDC has tailored its design methodologies to optimize the fabrication of space level hybrids. The intent of the design guidelines is to minimize the number of die and wirebonds, minimize the number of substrate layers, and maximize the space between components.

The BU-67402 is packaged in a 36-lead ceramic package. The use of ceramic eliminates the hermeticity problems associated with the glass beads used in Kovar (metal) packages. In addition, ceramic packages provide more rigid leads, better thermal properties, easier wirebonding, and lower weight.

The production of the space level hybrids can entail enhanced screening steps beyond DDC’s standard flow. This includes Condition A visual inspection, SEM analysis, and element evaluation for all integrated circuit die. For the hybrids, available screening options include Particle Impact Noise Detection (PIND), 320-hour burn-in, 100% non-destructive wirebond pull, X-ray analysis, as well as Destructive Physical Analysis (DPA) testing, extended temperature cycling for QCI testing, and a moisture content limit of 5000 PPM. Table 3 summarizes the procurement screening, element evaluation, and hybrid screening used in the production of the BU-67402.

Table 3. High Reliability Screening Options	
ELEMENT EVALUATION	METHOD
Visual Inspection: Integrated Circuits Transistors and Diodes Passive Components	MIL-STD-883, Method 2010 Condition A MIL-STD-750, Methods 2072 and 2073 MIL-STD-883, Method 2032 Class S
SEM Analysis for Integrated Circuits	MIL-STD-883, Method 2018

Table 3. High Reliability Screening Options	
<p>Element Evaluation: Visual. Electrical, Wire Bondability, 24-Hour Stabilization Bake, 10 Temperature Cycles, 3000 g's Constant Acceleration, 240-Hour Burn-in and 1000-Hour Life Test (Burn-In and Life Test are only required for active components.)</p>	<p>MIL-PRF-38534</p>
ASSEMBLY AND TEST	METHOD
Particle Impact Noise Detection (PIND)	MIL-STD-883, Method 2020 Condition A
320-Hour Burn-In (available on this device)	MIL-STD-883, Method 1015
100% Non-Destructive Wirebond Pull (available on this device)	MIL-STD-883, Method 2023
Radiographic (x-ray) analysis	MIL-STD-883, Method 2012
QCI TESTING	METHOD
Extended Temperature Cycling: 20 Cycles including Radiographic (X-Ray) Testing	MIL-STD-883, Method 1010 Condition C and MIL-STD-883, Method 2012
Moisture Content Limit of 5000 PPM	MIL-STD-883, Method 1018

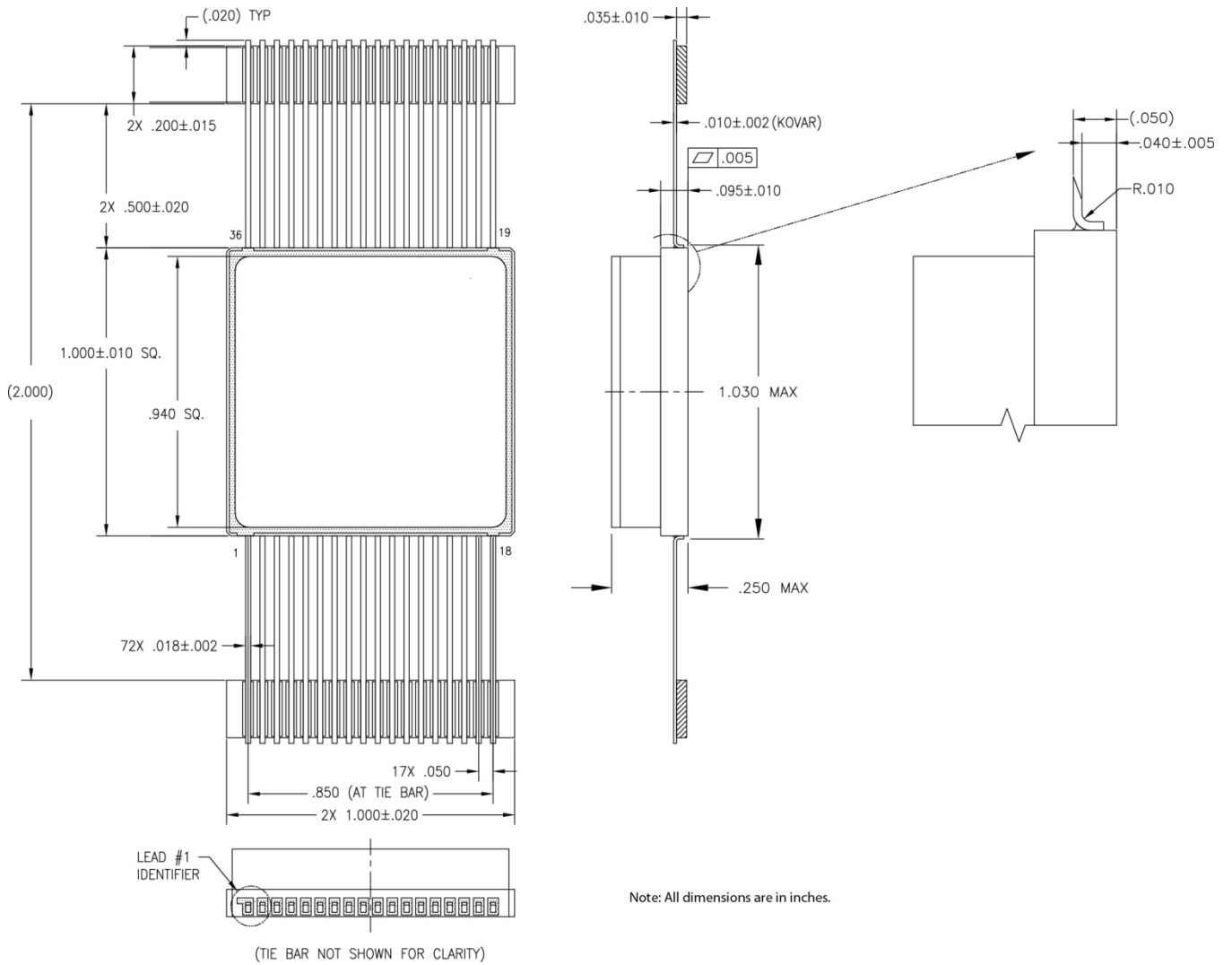

Figure 5. BU-67402 Mechanical Outline – SPACE-PHY 36-pin Flat Package

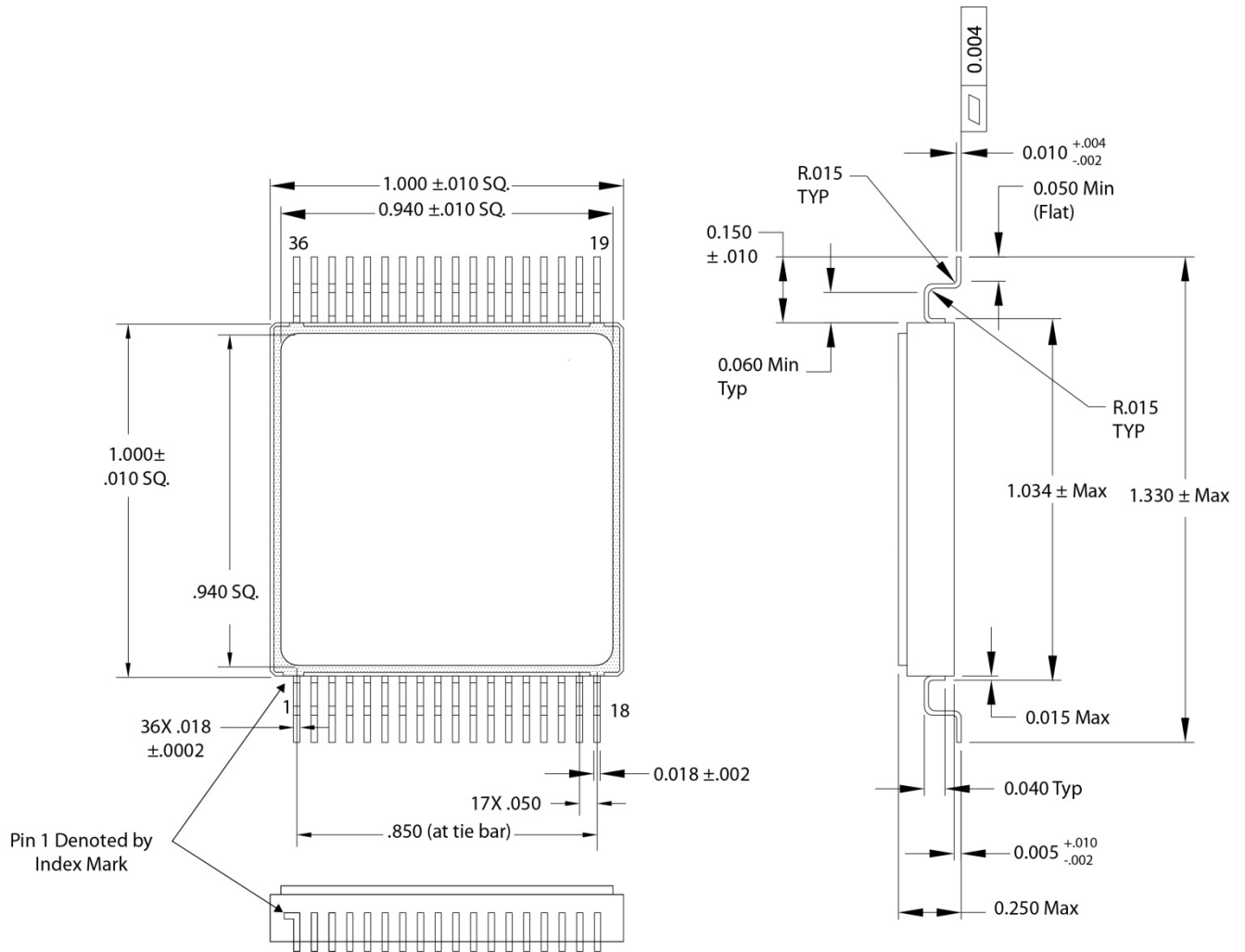

Figure 6. BU-67402 Mechanical Outline – SPACE-PHY 36-pin Gull Wing Package

Table 4. BU-67402 Pad Signal Descriptions					
Pin #	Name	I/O	Termination	Description	Connection
1	VCCA	PWR	-	+5V power input for Channel A Transceiver	+5V
2	GND	GND	-	Digital ground for Channel A and B transceivers	GND
3	RX_STROBE_A	IN	Internal Pull-up	Receive enable for channel A. Drive high to enable channel A receiver. Driving low will force RX_DATA_OUT_A and RX_DATA_OUT_A_L to '0' regardless of input waveform on bus pins.	Functional or Tie HIGH

Table 4. BU-67402 Pad Signal Descriptions

Pin #	Name	I/O	Termination	Description	Connection
4	RX_DATA_OUT_A	OUT	-	Complimentary digital receive outputs for channel A. Both signals will be low when the 1553 bus is idle.	Functional
5	RX_DATA_OUT_A_L	OUT	-		Functional
6	TXINH_A	IN	Internal Pull-down	Transmit inhibit for channel A. Drive high to prevent transmission.	Functional
7	TX_DATA_IN_A	IN	Internal Pull-down	Complimentary digital transmit inputs for channel A. Drive both signals low to idle bus when not transmitting.	Functional
8	TX_DATA_IN_A_L	IN	Internal Pull-down		Functional
9	RESERVED	-	Cover Metal Connection	Possible future direct connection to cover metal	GND or Chassis
10	RESERVED	-	-	Do not connect	None
11	RX_STROBE_B	IN	Internal Pull-up	Receive enable for channel B. Drive high to enable channel A receiver. Driving low will force RX_DATA_OUT_A and RX_DATA_OUT_A_L to '0' regardless of input waveform on bus pins.	Functional or Tie HIGH
12	RX_DATA_OUT_B	OUT	-	Complimentary digital receive outputs for channel B. Both signals will be low when the 1553 bus is idle.	Functional
13	RX_DATA_OUT_B_L	OUT	-		Functional
14	TXINH_B	IN	Internal Pull-down	Transmit inhibit for channel B. Drive high to prevent transmission.	Functional
15	TX_DATA_IN_B	IN	Internal Pull-down	Complimentary digital transmit inputs for channel B. Drive both signals low to idle bus when not transmitting.	Functional
16	TX_DATA_IN_B_L	IN	Internal Pull-down		Functional
17	GND	PWR	-	Digital ground for Channel A and B transceivers	GND
18	VCCB	PWR	-	+5V power input for Channel B Transceiver	+5V
19	VCCB	PWR	-	+5V power input for Channel B Transceiver	+5V
20	1553BUS_B_DC-N	I/O	Transformer Secondary	Negative direct-coupled stub connection for channel B	1553 Bus
21	1553BUS_B_XC-N	I/O	Transformer Secondary	Negative transformer-coupled stub connection for channel B	1553 Stub
22	1553BUS_B_CT	I/O	Transformer Secondary	Secondary center tap for channel B	Not Recommended
23	1553BUS_B_XC-P	I/O	Transformer Secondary	Positive transformer-coupled stub connection for channel B	1553 Stub

Table 4. BU-67402 Pad Signal Descriptions

Pin #	Name	I/O	Termination	Description	Connection
24	1553BUS_B_DC-P	I/O	Transformer Secondary	Positive direct-coupled stub connection for channel B	1553 Bus
25	RESERVED	-	-	Do not connect	None
26	RESERVED	-	-	Do not connect	None
27	AGND	PWR	Transformer Primary	Analog Ground. Primary center tap for both channels.	GND
28	AGND	PWR	Transformer Primary	Requires high-current path to ground.	GND
29	RESERVED	-	-	Do not connect	None
30	RESERVED	-	-	Do not connect	None
31	1553BUS_A_DC-N	I/O	Transformer Secondary	Negative direct-coupled stub connection for channel A	1553 Bus
32	1553BUS_A_XC-N	I/O	Transformer Secondary	Negative transformer-coupled stub connection for channel A	1553 Stub
33	1553BUS_A_CT	I/O	Transformer Secondary	Secondary center tap for channel A	Not Recommended
34	1553BUS_A_XC-P	I/O	Transformer Secondary	Positive transformer-coupled stub connection for channel A	1553 Stub
35	1553BUS_A_DC-P	I/O	Transformer Secondary	Positive direct-coupled stub connection for channel A	1553 Bus
36	VCCA	PWR	-	+5V power input for Channel A Transceiver	+5V

4 ORDERING INFORMATION

BU-67402F0GHL-X X X X

Supplemental Process Requirements:

S = Pre-Cap Source Inspection
L = 100% Pull Test
Q = 100% Pull test and Pre-Cap Source Inspection
K = One Lot Data Code
W = One Lot Data Code and Pre-Cap Source Inspection
Y = One Lot Date Code and 100% Pull Test
Z = One Lot Date Code, Pre-Cap Source Inspection and 100% Pull Test
Blank = None of the Above

Other Options:

0 = No X-Ray
1 = X-Ray

Process Requirements:

1 = MIL-PRF-38534 Compliant (note 1)
3 = MIL-PRF-38534 Compliant with PIND Testing (note 1)
4 = MIL-PRF-38534 Compliant with Solder Dip (notes 1, 2)
5 = MIL-PRF-38534 Compliant with PIND Testing and Solder Dip (notes 1, 2)

Temperature Grade/Data Requirements:

1 = -55°C to +125°C
4 = -55°C to +125°C with Variables Test Data

MIL-PRF-38534 Compliance:

H = Class H
K = Class K (note 3)

Package:

F = Flat Pack
G = Gull Leads (note 4)

Notes:

1. Standard processing on this device includes 320 hours of burn-in.
2. These products contain tin-lead solder finish as applicable to solder dip requirements.
3. MIL-PRF-38534 Class K requires PIND testing, X-Ray and 100% Pull Test (-X31X or -X51X with L, Q, Y or Z as the last digit)
4. Gull wing package requires solder dip (-X4XX or -X5XX)

Standard DDC Processing for Hybrid and Monolithic Hermetic Products		
Test	MIL-STD-883	
	Method(s)	Condition(s)
Inspection	2009, 2010, 2017, and 2032	—
Seal	1014	A and C
Temperature Cycle	1010	C
Constant Acceleration	2001	3000g
Burn-In	1015 (note 1), 1030 (note 2)	Table 1

Notes:

1. For Process Requirements "B*" (refer to ordering information), devices may be non-compliant with MIL-STD-883, Test Method 1015, Paragraph 3.2. Contact factory for details.
2. When applicable.

Data Device Corporation

Leadership Built on Nearly 50 Years of Innovation

Military | Commercial Aerospace | Space | Industrial

Data Device Corporation (DDC) is the world leader in the design and manufacture of high-reliability data bus products, motion control, and solid-state power controllers for aerospace, defense, and industrial automation applications. For nearly 50 years, DDC has continuously advanced the state of high-reliability data communications and control technology for MIL-STD-1553, ARINC 429, Synchro/Resolver interface, and Solid-State Power Controllers with innovations that have minimized component size and weight while increasing performance. DDC offers a broad product line consisting of advanced data bus technology for Fibre Channel networks; MIL-STD-1553 and ARINC 429 Data Networking cards, components, and software; Synchro/Resolver interface components; and Solid-State Power Controllers and Motor Drives.

Product Families

Data Bus | Synchro/Resolver | Power Controllers | Motor Drives

DDC is a leader in the development, design, and manufacture of highly reliable and innovative military data bus solutions. DDC's Data Networking Solutions include MIL-STD-1553, ARINC 429, and Fibre Channel. Each Interface is supported by a complete line of quality MIL-STD-1553 and ARINC 429 commercial, military, and COTS grade cards and components, as well as software that maintain compatibility between product generations. The Data Bus product line has been field proven for the military, commercial and aerospace markets.

DDC is also a global leader in Synchro/Resolver Solutions. We offer a broad line of Synchro/Resolver instrument-grade cards, including angle position indicators and simulators. Our Synchro/Resolver-to-Digital and Digital-to-Synchro/Resolver microelectronic components are the smallest, most accurate converters, and also serve as the building block for our card-level products. All of our Synchro/Resolver line is supported by software, designed to meet today's COTS/MOTS needs. The Synchro/Resolver line has been field proven for military and industrial applications, including radar, IR, and navigation systems, fire control, flight instrumentation/simulators, motor/motion feedback controls and drivers, and robotic systems.

As the world's largest supplier of Solid-State Power Controllers (SSPCs) and Remote Power Controllers (RPCs), DDC was the first to offer commercial and fully-qualified MIL-PRF-38534 and Class K Space-level screening for these products. DDC's complete line of SSPC and RPC boards and components support real-time digital status reporting and computer control, and are equipped with instant trip, and true I²T wire protection. The SSPC and RPC product line has been field proven for military markets, and are used in the Bradley fighting vehicles and M1A2 tank.

DDC is the premier manufacturer of hybrid motor drives and controllers for brush, 3-phase brushless, and induction motors operating from 28 Vdc to 270 Vdc requiring up to 18 kilowatts of power. Applications range from aircraft actuators for primary and secondary flight controls, jet or rocket engine thrust vector control, missile flight controls, to pumps, fans, solar arrays and momentum wheel control for space and satellite systems.

Certifications

Data Device Corporation is ISO 9001: 2008 and AS 9100, Rev. C certified.

DDC has also been granted certification by the Defense Supply Center Columbus (DSCC) for manufacturing Class D, G, H, and K hybrid products in accordance with MIL-PRF-38534, as well as ESA and NASA approved.

Industry documents used to support DDC's certifications and Quality system are: AS9001 OEM Certification, MIL-STD-883, ANSI/NCSL Z540-1, IPC-A-610, MIL-STD-202, JESD-22, and J-STD-020.





DATA DEVICE CORPORATION
REGISTERED TO:
ISO 9001:2008, AS9100C:2009-01
EN9100:2009, JIS Q9100:2009
FILE NO. 10001296 ASH09



The first choice for more than 45 years—DDC

DDC is the world leader in the design and manufacture of high reliability data interface products, motion control, and solid-state power controllers for aerospace, defense, and industrial automation.

Inside the U.S. - Call Toll-Free 1-800-DDC-5757

Headquarters and Main Plant

105 Wilbur Place, Bohemia, NY 11716-2426
Tel: (631) 567-5600 Fax: (631) 567-7358
Toll-Free, Customer Service: 1-800-DDC-5757

Web site: www.ddc-web.com



Data Device Corporation

Outside the U.S. - Call 1-631-567-5700

United Kingdom: DDC U.K., LTD

Mill Reef House, 9-14 Cheap Street, Newbury,
Berkshire RG14 5DD, England
Tel: +44 1635 811140 Fax: +44 1635 32264

France: DDC Electronique

10 Rue Carle-Herbert
92400 Courbevoie France
Tel: +33-1-41-16-3424 Fax: +33-1-41-16-3425

Germany: DDC Elektronik GmbH

Triebstrasse 3, D-80993 München, Germany
Tel: +49 (0) 89-15 00 12-11
Fax: +49 (0) 89-15 00 12-22

Japan: DDC Electronics K.K.

Dai-ichi Magami Bldg, 8F, 1-5, Koraku 1-chome,
Bunkyo-ku, Tokyo 112-0004, Japan
Tel: 81-3-3814-7688 Fax: 81-3-3814-7689
Web site: www.ddcjapan.co.jp

Asia: Data Device Corporation - RO Registered in Singapore

Blk-327 Hougang Ave 5 #05-164
Singapore 530327
Tel: +65 6489 4801