

To our customers,

Old Company Name in Catalogs and Other Documents

On April 1st, 2010, NEC Electronics Corporation merged with Renesas Technology Corporation, and Renesas Electronics Corporation took over all the business of both companies. Therefore, although the old company name remains in this document, it is a valid Renesas Electronics document. We appreciate your understanding.

Renesas Electronics website: <http://www.renesas.com>

April 1st, 2010
Renesas Electronics Corporation

Issued by: Renesas Electronics Corporation (<http://www.renesas.com>)

Send any inquiries to <http://www.renesas.com/inquiry>.

Notice

1. All information included in this document is current as of the date this document is issued. Such information, however, is subject to change without any prior notice. Before purchasing or using any Renesas Electronics products listed herein, please confirm the latest product information with a Renesas Electronics sales office. Also, please pay regular and careful attention to additional and different information to be disclosed by Renesas Electronics such as that disclosed through our website.
2. Renesas Electronics does not assume any liability for infringement of patents, copyrights, or other intellectual property rights of third parties by or arising from the use of Renesas Electronics products or technical information described in this document. No license, express, implied or otherwise, is granted hereby under any patents, copyrights or other intellectual property rights of Renesas Electronics or others.
3. You should not alter, modify, copy, or otherwise misappropriate any Renesas Electronics product, whether in whole or in part.
4. Descriptions of circuits, software and other related information in this document are provided only to illustrate the operation of semiconductor products and application examples. You are fully responsible for the incorporation of these circuits, software, and information in the design of your equipment. Renesas Electronics assumes no responsibility for any losses incurred by you or third parties arising from the use of these circuits, software, or information.
5. When exporting the products or technology described in this document, you should comply with the applicable export control laws and regulations and follow the procedures required by such laws and regulations. You should not use Renesas Electronics products or the technology described in this document for any purpose relating to military applications or use by the military, including but not limited to the development of weapons of mass destruction. Renesas Electronics products and technology may not be used for or incorporated into any products or systems whose manufacture, use, or sale is prohibited under any applicable domestic or foreign laws or regulations.
6. Renesas Electronics has used reasonable care in preparing the information included in this document, but Renesas Electronics does not warrant that such information is error free. Renesas Electronics assumes no liability whatsoever for any damages incurred by you resulting from errors in or omissions from the information included herein.
7. Renesas Electronics products are classified according to the following three quality grades: “Standard”, “High Quality”, and “Specific”. The recommended applications for each Renesas Electronics product depends on the product’s quality grade, as indicated below. You must check the quality grade of each Renesas Electronics product before using it in a particular application. You may not use any Renesas Electronics product for any application categorized as “Specific” without the prior written consent of Renesas Electronics. Further, you may not use any Renesas Electronics product for any application for which it is not intended without the prior written consent of Renesas Electronics. Renesas Electronics shall not be in any way liable for any damages or losses incurred by you or third parties arising from the use of any Renesas Electronics product for an application categorized as “Specific” or for which the product is not intended where you have failed to obtain the prior written consent of Renesas Electronics. The quality grade of each Renesas Electronics product is “Standard” unless otherwise expressly specified in a Renesas Electronics data sheets or data books, etc.
 - “Standard”: Computers; office equipment; communications equipment; test and measurement equipment; audio and visual equipment; home electronic appliances; machine tools; personal electronic equipment; and industrial robots.
 - “High Quality”: Transportation equipment (automobiles, trains, ships, etc.); traffic control systems; anti-disaster systems; anti-crime systems; safety equipment; and medical equipment not specifically designed for life support.
 - “Specific”: Aircraft; aerospace equipment; submersible repeaters; nuclear reactor control systems; medical equipment or systems for life support (e.g. artificial life support devices or systems), surgical implantations, or healthcare intervention (e.g. excision, etc.), and any other applications or purposes that pose a direct threat to human life.
8. You should use the Renesas Electronics products described in this document within the range specified by Renesas Electronics, especially with respect to the maximum rating, operating supply voltage range, movement power voltage range, heat radiation characteristics, installation and other product characteristics. Renesas Electronics shall have no liability for malfunctions or damages arising out of the use of Renesas Electronics products beyond such specified ranges.
9. Although Renesas Electronics endeavors to improve the quality and reliability of its products, semiconductor products have specific characteristics such as the occurrence of failure at a certain rate and malfunctions under certain use conditions. Further, Renesas Electronics products are not subject to radiation resistance design. Please be sure to implement safety measures to guard them against the possibility of physical injury, and injury or damage caused by fire in the event of the failure of a Renesas Electronics product, such as safety design for hardware and software including but not limited to redundancy, fire control and malfunction prevention, appropriate treatment for aging degradation or any other appropriate measures. Because the evaluation of microcomputer software alone is very difficult, please evaluate the safety of the final products or system manufactured by you.
10. Please contact a Renesas Electronics sales office for details as to environmental matters such as the environmental compatibility of each Renesas Electronics product. Please use Renesas Electronics products in compliance with all applicable laws and regulations that regulate the inclusion or use of controlled substances, including without limitation, the EU RoHS Directive. Renesas Electronics assumes no liability for damages or losses occurring as a result of your noncompliance with applicable laws and regulations.
11. This document may not be reproduced or duplicated, in any form, in whole or in part, without prior written consent of Renesas Electronics.
12. Please contact a Renesas Electronics sales office if you have any questions regarding the information contained in this document or Renesas Electronics products, or if you have any other inquiries.

(Note 1) “Renesas Electronics” as used in this document means Renesas Electronics Corporation and also includes its majority-owned subsidiaries.

(Note 2) “Renesas Electronics product(s)” means any product developed or manufactured by or for Renesas Electronics.

MONOLITHIC 6-CHANNEL H BRIDGE DRIVER

DESCRIPTION

The μ PD168102 is a monolithic 6-channel H bridge driver IC consisting of a CMOS controller and a MOS output stage. Because it uses a MOS process, this driver IC consumes less current and loses less voltage at the output stage than conventional driver ICs that use bipolar transistors. In addition, the μ PD168102 employs P-channel MOSFETs in its output stage, eliminating the need for an on-chip the charge pump circuit. Therefore, the current consumption during circuit operation can be significantly reduced.

Of the six output channels, four channels are voltage drive type and two channels are current drive type (voltage drive is also possible). The current drive method of the μ PD168102 is the output chopping method, which realizes lower power consumption drive than the conventional high-power-dissipation linear drive method.

The μ PD168102 is housed in a 48-pin WQFN to decrease the mounting area and height. The μ PD168102 can simultaneously drive two stepper motors and two DC motors and is ideal for the motor driver of digital still cameras.

FEATURES

- Six H bridge circuits employing power MOSFETs
- Voltage drive type: 4 channels, current drive type (constant current chopping type): 2 channels
- Low current consumption due to elimination of charge pump circuit
- Input logic frequency: 100 kHz supported
- 3 V power supply supported
- Minimum operating supply voltage: 2.5 V
- Low voltage malfunction prevention circuit
- Internal circuit shutdown at $V_{DD} < 2.5$ V
- On-chip overheat protection circuit
- 48-pin WQFN (7 mm \times 7 mm)

ORDERING INFORMATION

Part Number	Package
μ PD168102K9-5B4	48-pin plastic WQFN (7 mm \times 7 mm)

The information in this document is subject to change without notice. Before using this document, please confirm that this is the latest version.
Not all devices/types available in every country. Please check with local NEC representative for availability and additional information.

PIN FUNCTIONSPackage: 48-pin WQFN (7 mm \times 7 mm)

Pin No.	Pin Name	Pin Function
1	BRKsel	Stop mode switching pin when output open
2	V _{DD}	Control block power supply pin
3	PGND	Output GND pin
4	OUT _{1B}	Ch 1 output pin
5	V _{M1}	Ch 1 output block power supply pin
6	OUT _{1A}	Ch 1 output pin
7	PGND	Output block GND pin
8	OUT _{2B}	Ch 2 output pin
9	V _{M2}	Ch 2 output block power supply pin
10	OUT _{2A}	Ch 2 output pin
11	PGND	Output block GND pin
12	DGND	Control block GND pin
13	I _{SEN5}	Ch 5 current sense signal input pin
14	CL ₅	Ch 5 reference voltage input pin
15	V _{M5}	Ch 5 output block power supply pin
16	OUT _{5B}	Ch 5 output pin
17	RF ₅	Ch 5 sense resistor connection pin
18	OUT _{5A}	Ch 5 output pin
19	V _{M5}	Ch 5 output block power supply pin
20	V _{M6}	Ch 6 output block power supply pin
21	OUT _{6B}	Ch 6 output pin
22	RF ₆	Ch 6 sense resistor connection pin
23	OUT _{6A}	Ch 6 output pin
24	V _{M6}	Ch 6 output block power supply pin
25	CL ₆	Ch 6 reference voltage input pin
26	I _{SEN6}	Ch 6 current sense signal input pin
27	PGND	Output block GND pin
28	OUT _{3A}	Ch 3 output pin
29	V _{M3}	Ch 3 output block power supply pin
30	OUT _{3B}	Ch 3 output pin
31	PGND	Output block GND pin
32	OUT _{4A}	Ch 4 output pin
33	V _{M4}	Ch 4 output block power supply pin
34	OUT _{4B}	Ch 4 output pin
35	PGND	Output block GND pin
36	V _I sel	Voltage/current control switching pin (ch 5, ch 6)
37	IN ₁₂	Ch 6 input pin
38	IN ₁₁	Ch 6 input pin
39	IN ₁₀	Ch 5 input pin
40	IN ₉	Ch 5 input pin
41	IN ₈	Ch 4 input pin
42	IN ₇	Ch 4 input pin
43	IN ₆	Ch 3 input pin
44	IN ₅	Ch 3 input pin
45	IN ₄	Ch 2 input pin
46	IN ₃	Ch 2 input pin
47	IN ₂	Ch 1 input pin
48	IN ₁	Ch 1 input pin

Caution Multiple pins with the same function must all be connected.

BLOCK DIAGRAM

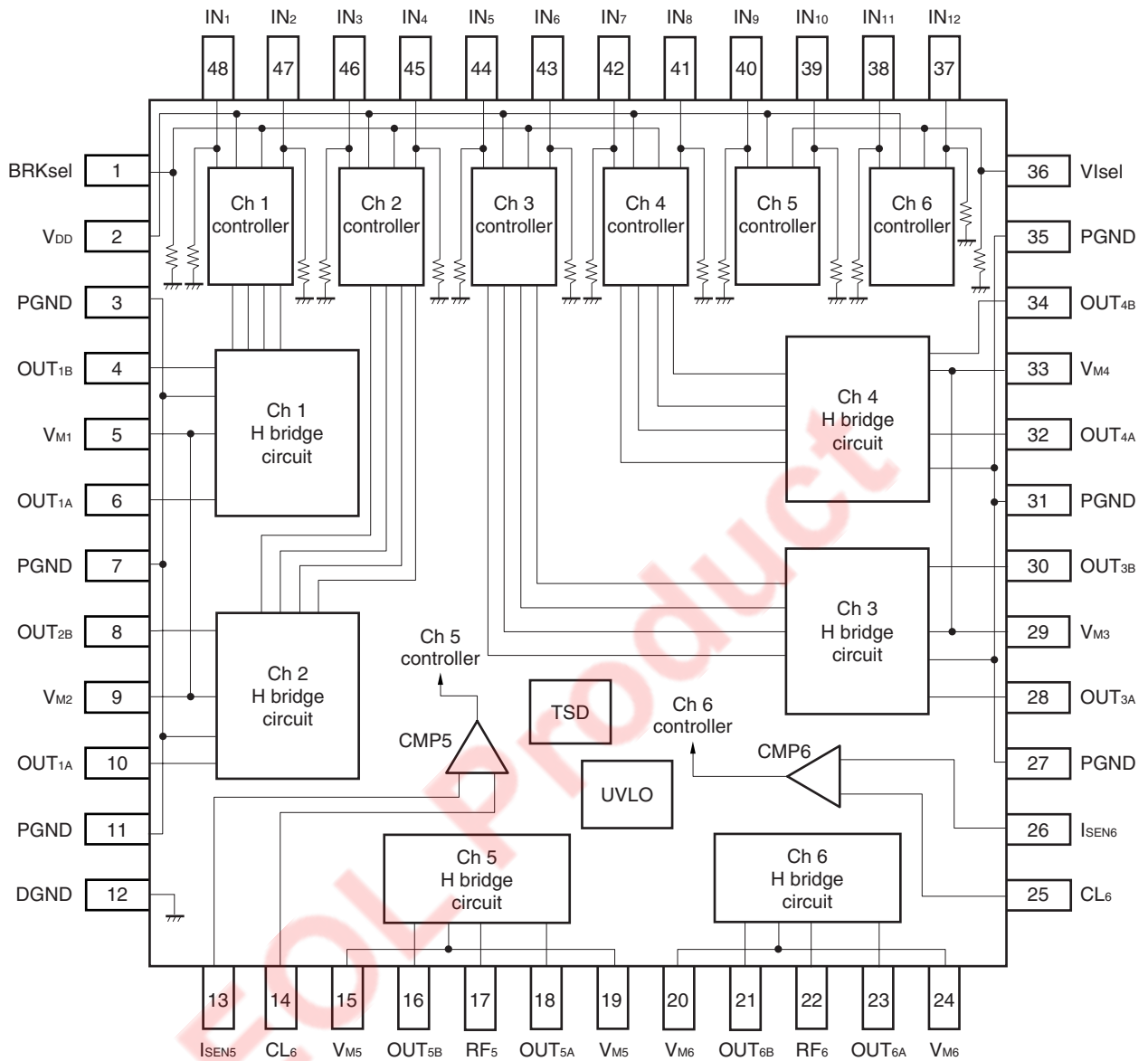

Caution Multiple pins with the same function must all be connected. The motor power supply pins V_{M1} and V_{M2} , and V_{M3} and V_{M4} are internally connected, so be sure to apply the same potential to them.

FUNCTION OPERATION TABLE

The logic of each channel is shown in the table below.

I/O Truth Table for Channels 1 to 6

Input			Output		Output Status	Operating Mode of Ch 5 and Ch 6
VIsel	IN1, 3, 5, 7, 9, 11	IN2, 4, 6, 8, 10, 12	OUTA	OUTB		
L	L	L	Z	Z	Stopped (output open, standby)	Voltage control output
	L	H	L	H	Reverse (OUTB → OUTA)	
	H	L	H	L	Forward (OUTA → OUTB)	
	H	H	L	L	Stopped (short brake)	
H	L	L	Z	Z	Stopped (output open)	Constant current chopping
	L	H	L	H	Reverse (OUTB → OUTA)	
	H	L	H	L	Forward (OUTA → OUTB)	
	H	H	L	L	Stopped (short brake)	

H: High level, L: Low level, Z: High impedance

Constant current chopping is possible for channels 5 and 6.

When VIsel is set to high level, if the voltage becomes higher than the reference voltage (external input) and the current becomes higher than the current set by the feedback resistor, the output can be forcibly chopped.

When VIsel is set to low level, channels 5 and 6 function in the same way as channels 1 to 4.

Standby function

The μPD168102 realizes a standby function by combining the input signals.

By setting all the control input signals of channels 1 to 6 to low level, a standby mode in which the current consumption of the internal circuit is suppressed is entered. Note that the output status is high impedance (output open).

BRKsel pin function

By using the logic of BRKsel, whether the function that prevents the motor power supply rising in the Hi-Z output status (input L, L) is enabled or disabled can be selected. Refer to the truth table below.

BRKsel Truth Table

BRKsel	Function
L	Hi-Z status
H	Regenerates output current using an internal channel. An internal timer is incorporated, through which the regeneration period is set for approx. 1 ms, and then the Hi-Z status is entered.

ABSOLUTE MAXIMUM RATINGS (T_A = 25°C: MOUNTED ON GLASS EPOXY BOARD 100 mm × 100 mm × 1 mm, COPPER FILM AREA: 15%)

Parameter	Symbol	Conditions	Ratings	Unit
Supply voltage	V _{DD}	Control block	-0.5 to +6.0	V
	V _M	Motor block	-0.5 to +6.0	
Input voltage	V _{IN}		-0.5 to V _{DD} +0.5	V
Output pin voltage	V _{OUT}	Ch 1 to ch 4	6.2	V
		Ch 5, ch 6	5.7	
DC output current 1 (ch 1 to ch 4)	I _{D(DC)1}	DC	±0.3	A/ch
DC output current 2 (ch 5, ch 6)	I _{D(DC)2}	DC	±0.5	A/ch
Instantaneous output current 1 (ch 1 to ch 4)	I _{D(pulse)1}	PW < 10 ms, duty ≤ 20%	±0.6	A/ch
Instantaneous output current 2 (ch 5, ch 6)	I _{D(pulse)2}	PW < 10 ms, duty ≤ 20%	±1.0	A/ch
Power consumption	P _T		1.0	W
Peak junction temperature	T _{CH(MAX)}		150	°C
Storage temperature	T _{stg}		-55 to +150	°C

RECOMMENDED OPERATING CONDITIONS (T_A = 25°C: MOUNTED ON GLASS EPOXY BOARD 100 mm × 100 mm × 1 mm, COPPER FILM AREA: 15%)

Parameter	Symbol	Conditions	MIN.	TYP.	MAX.	Unit
Supply voltage	V _{DD}	Control block	2.5		5.5	V
	V _M	Motor block	2.7		5.5	V
Input voltage	V _{IN1}		0		V _{DD}	V
	V _{IN2}	CL pin	0.1		0.5	V
DC output current 1 (ch 1 to ch 4)	I _{D(DC)1}	DC	-0.2		+0.2	A/ch
DC output current 2 (ch 5, ch 6)	I _{D(DC)2}	DC	-0.4		+0.4	A/ch
Instantaneous output current 1 (ch 1 to ch 4)	I _{D(pulse)1}	PW < 10 ms, duty ≤ 20%	-0.4		+0.4	A/ch
Instantaneous output current 2 (ch 5, ch 6)	I _{D(pulse)2}	PW < 10 ms, duty ≤ 20%	-0.8		+0.8	A/ch
Logic input frequency	f _{IN}				100	kHz
Operating temperature range	T _A		-10		85	°C
Peak junction temperature	T _{CH(MAX)}				125	°C

ELECTRICAL SPECIFICATIONS (Unless otherwise specified, $V_{DD} = V_M = 3\text{ V}$, $T_A = 25^\circ\text{C}$)

Parameter	Symbol	Conditions	MIN.	TYP.	MAX.	Unit
V_{DD} pin current in standby mode	$I_{DD(STB)}$				1.0	μA
V_{DD} pin current when operating	$I_{DD(ACT)}$				1.0	mA
Input current, high	I_{IH}	$V_{IN} = V_{DD}$			60	μA
Input current, low	I_{IL}	$V_{IN} = 0$	-1.0			μA
Input pull-down resistor	R_{IND}		50		200	k Ω
Input voltage, high	V_{IH}	$2.5\text{ V} \leq V_{DD} \leq 5.5\text{ V}$	$0.7 \times V_{DD}$			V
Input voltage, low	V_{IL}	$2.5\text{ V} \leq V_{DD} \leq 5.5\text{ V}$			$0.3 \times V_{DD}$	V
H bridge on-resistance 1 (ch 1 to ch 4)	R_{ON1}	$I_M = 0.2\text{ A}$, sum of the top and bottom stages		1.5	2.0	Ω
H bridge on-resistance 2 (ch 5, ch 6)	R_{ON2}	$I_M = 0.4\text{ A}$, $R_{F5}, R_{F6} = 0\text{ V}$, sum of the top and bottom stages		1.0	1.5	Ω
Output leakage current	$I_{M(OFF)}$	Per V_M pin, $V_M = 5.5\text{ V}$, all control pins are low level			10	μA
Current detection comparator offset voltage	V_{CO}	$V_{CL} = 0.1\text{ V}$	-10		10	mV
Detection voltage at low voltage	V_{DDS}				2.5	V
Output turn-on time	t_{ON}	$R_M = 20\ \Omega$, see Figure 1		0.7	2.0	μs
Output turn-off time	t_{OFF}			0.2	0.5	μs
All-off time at mode change	t_{HIz}		50			ns
Rise time	t_r	$R_M = 20\ \Omega$, see Figure 1		0.3		μs
Fall time	t_f			0.1		μs
Current detection comparator operation delay time	t_{CDL}	$V_{CL} = 0.1\text{ V}$, $V_{ISEN} = 0\text{ V} \longleftrightarrow 0.2\text{ V}$, see Figure 2		0.4	1.0	μs

The overheat protection circuit operates at $T_{ch} > 150^\circ\text{C}$. In the overheat protected status, all outputs are high impedance.

In the standby mode, the overheat protection circuit and the low-voltage malfunction prevention circuit do not operate.

SWITCHING CHARACTERISTICS WAVEFORMS

Figure 1. H Bridge Switching Waveform

(1) IN2 = Low level

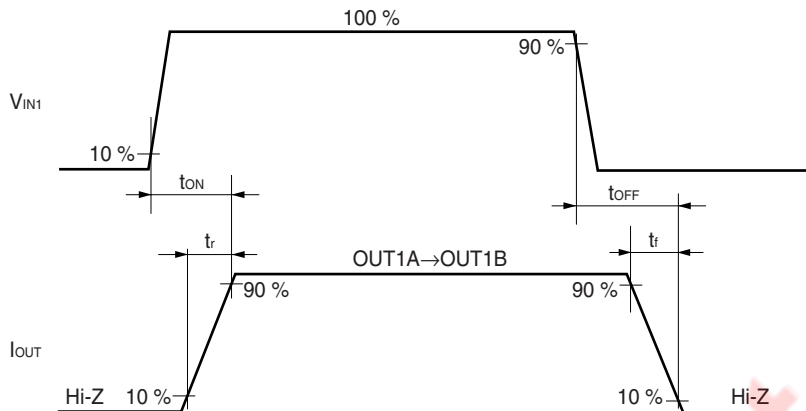

(2) IN2 = High level

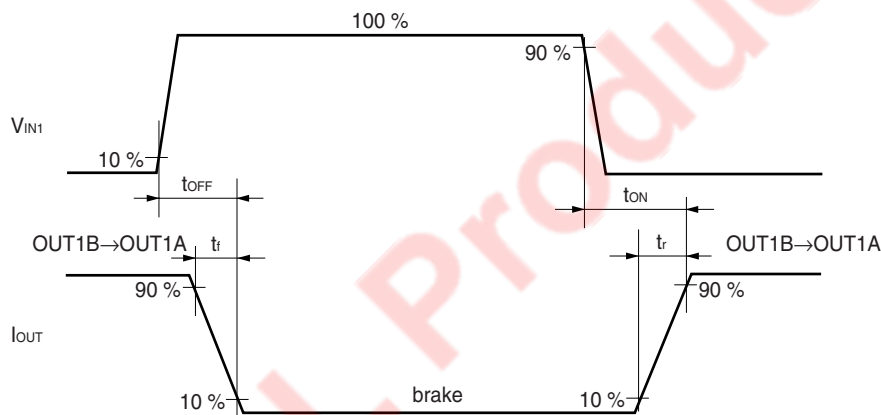

A high impedance period of approx. 50 ns is secured to prevent through current when switching the mode.

Figure 2. Current Detection Comparator Switching Waveform

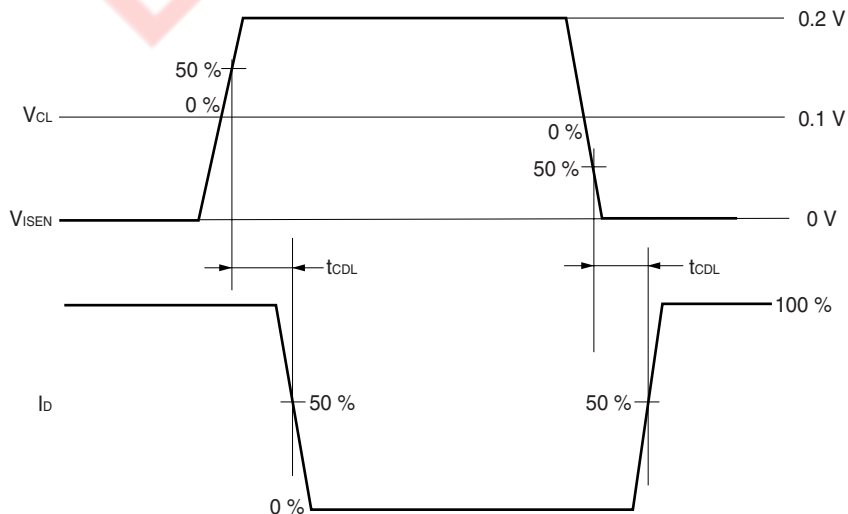

TOTAL POWER DISSIPATION AND OPERATING AMBIENT TEMPERATURE CHARACTERISTICS

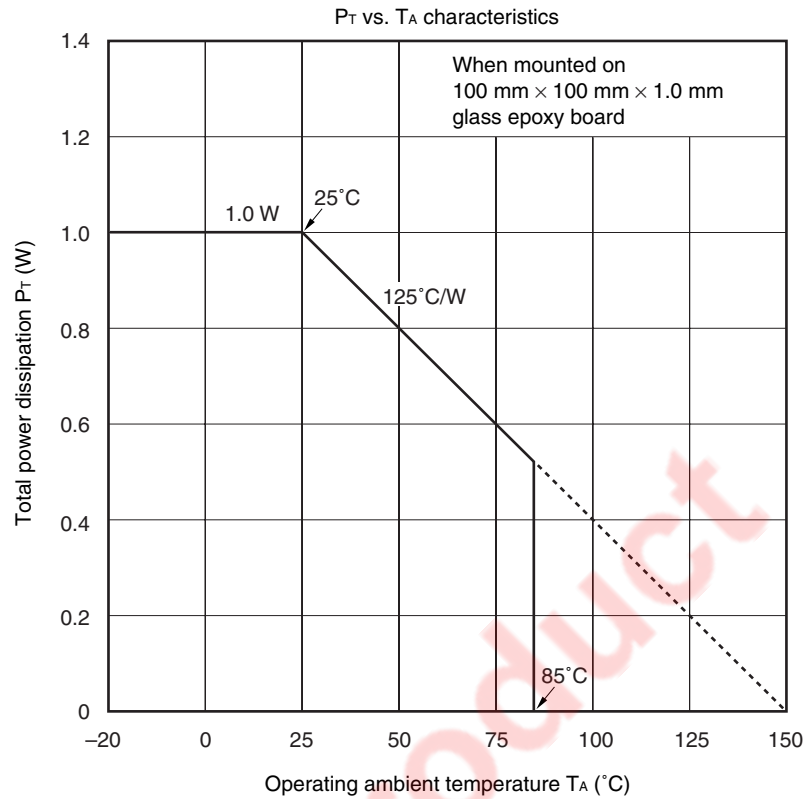

Remark When the operating ambient temperature is 25°C or lower, power application up to 1 W is possible. When the operating ambient temperature is higher than 25°C, perform derating in accordance with the above figure. In addition, when at 85°C (operating ambient temperature recommended condition), power application up to 0.52 W is possible.

CHARACTERISTICS CURVES

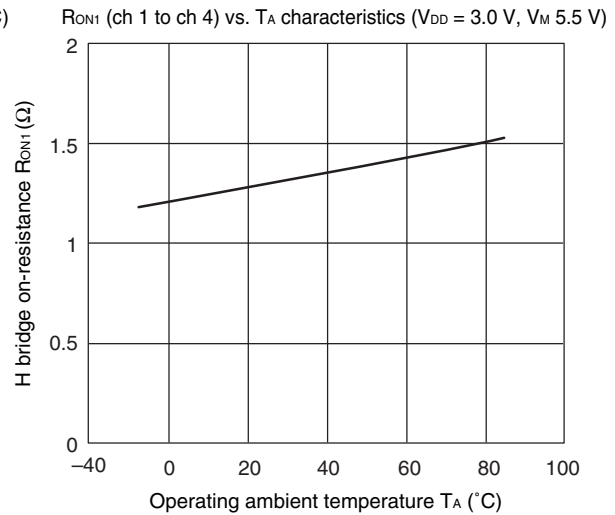
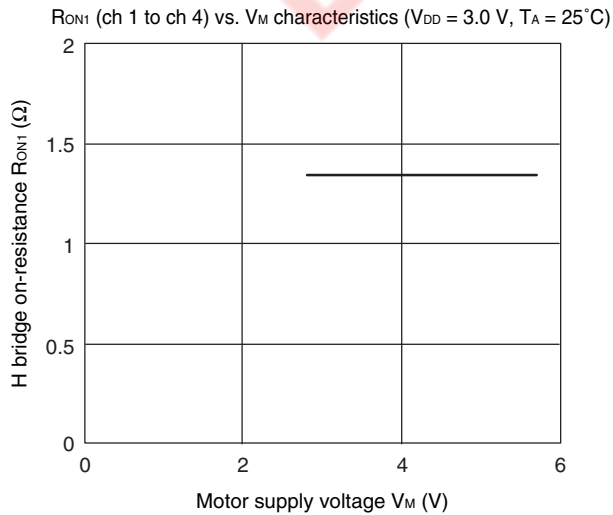
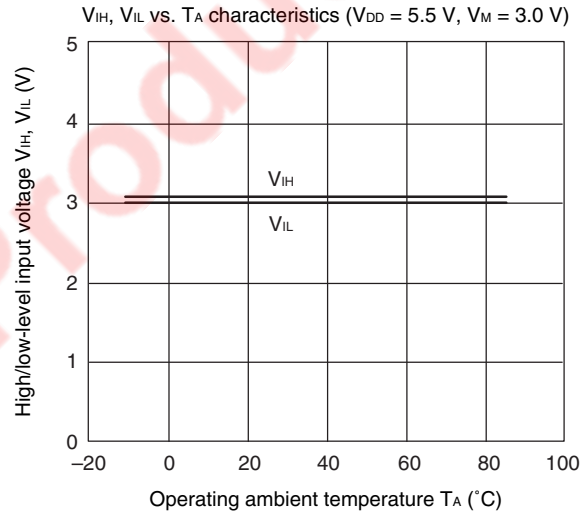
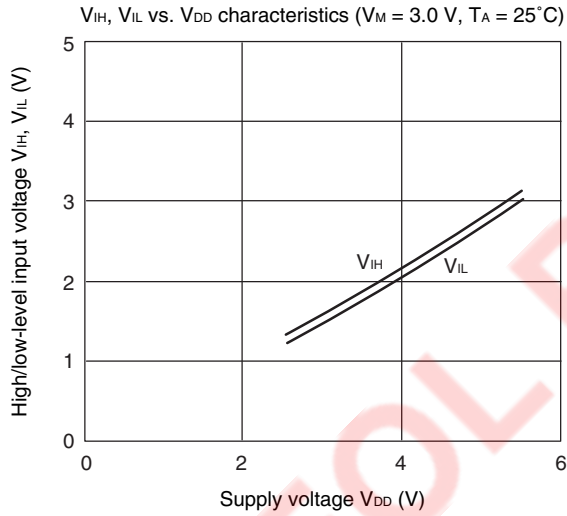
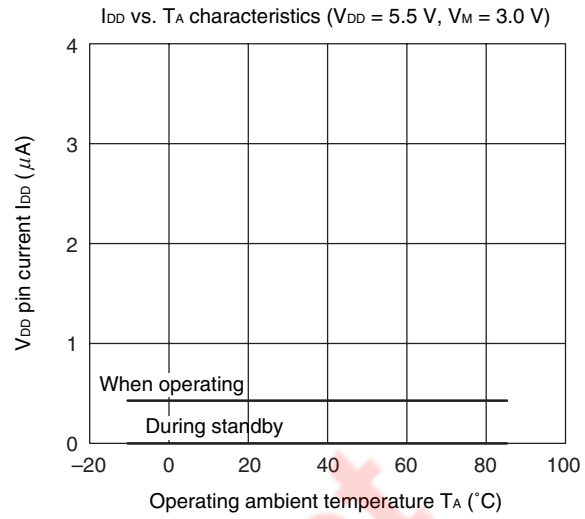
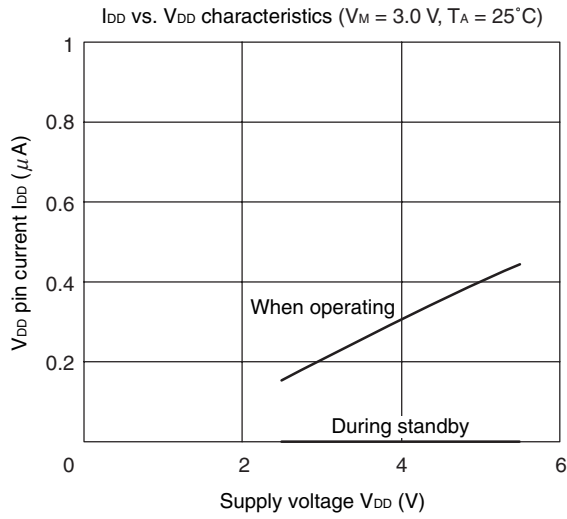

CHARACTERISTICS CURVES

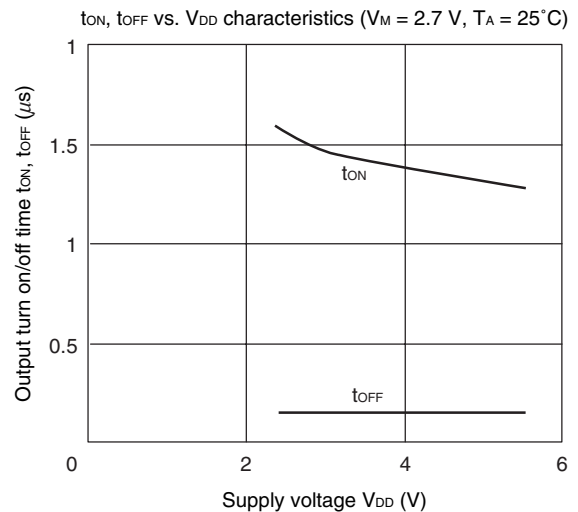
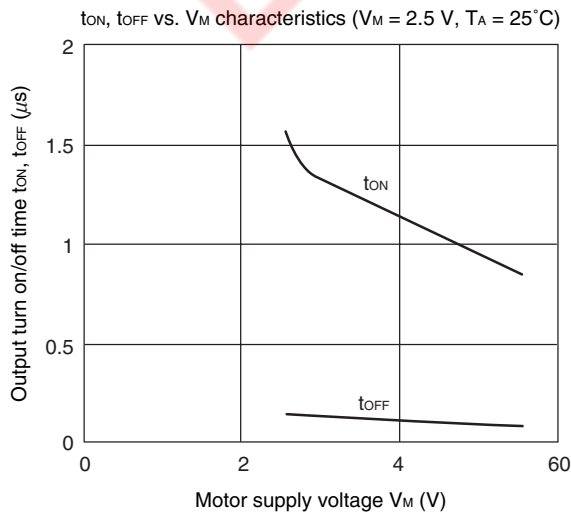
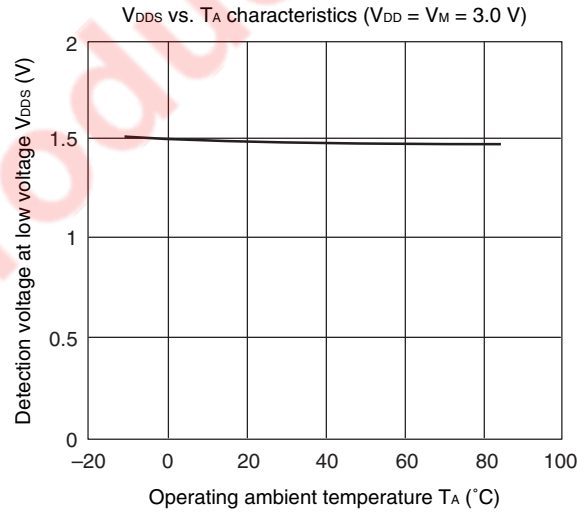
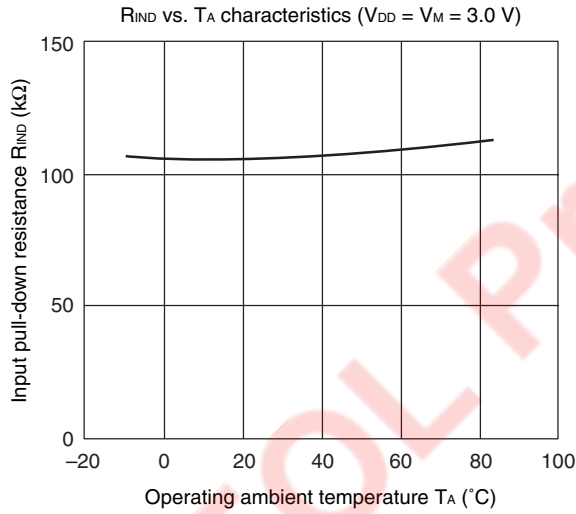
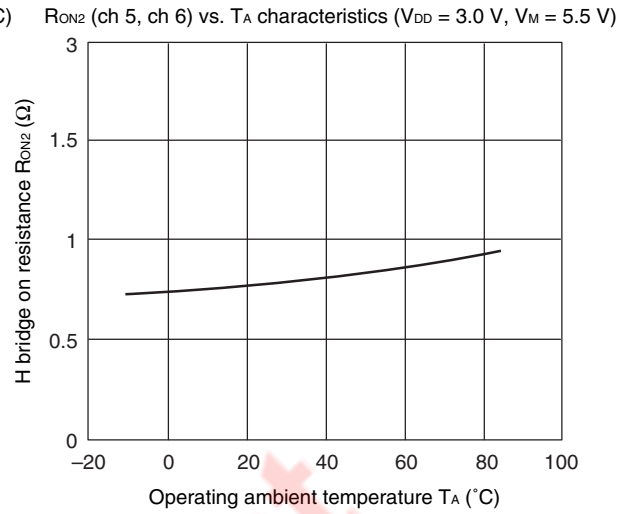
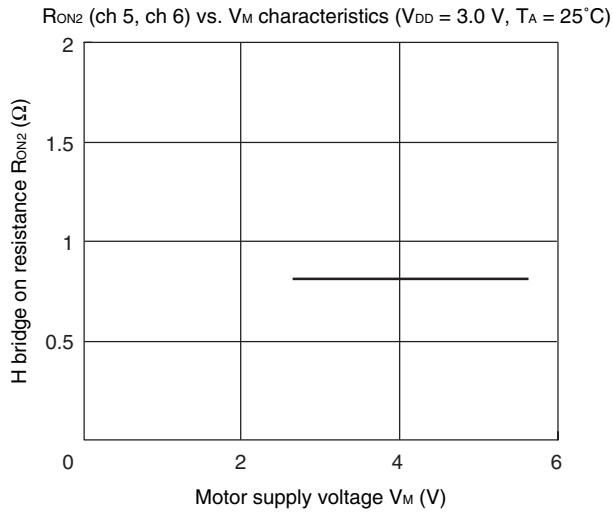

CHARACTERISTICS CURVES

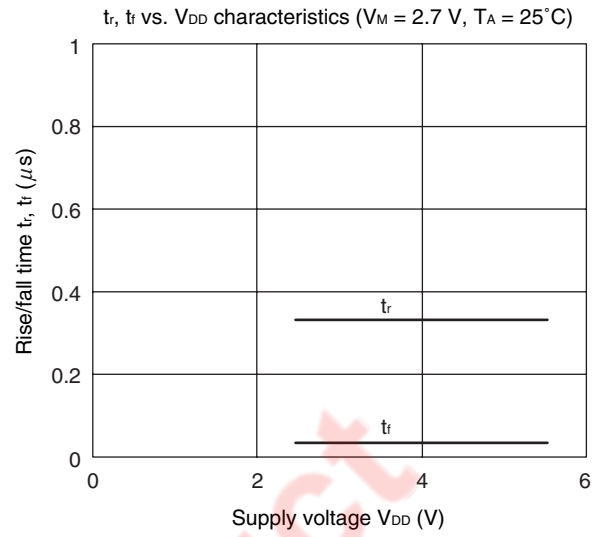
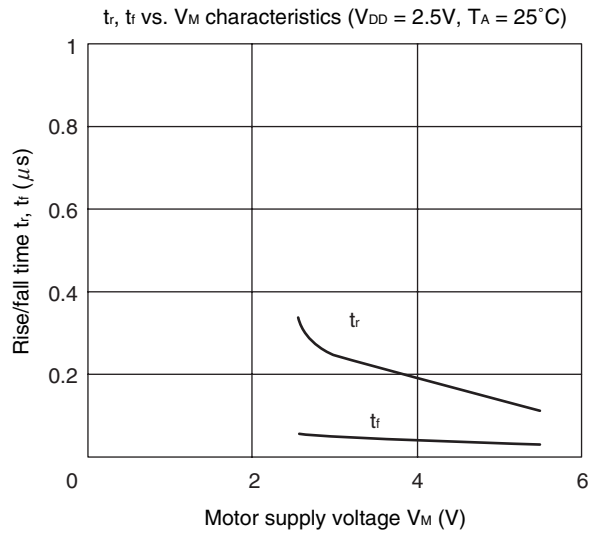

EOL Product

PACKAGE DRAWING

48-PIN PLASTIC WQFN (7x7)

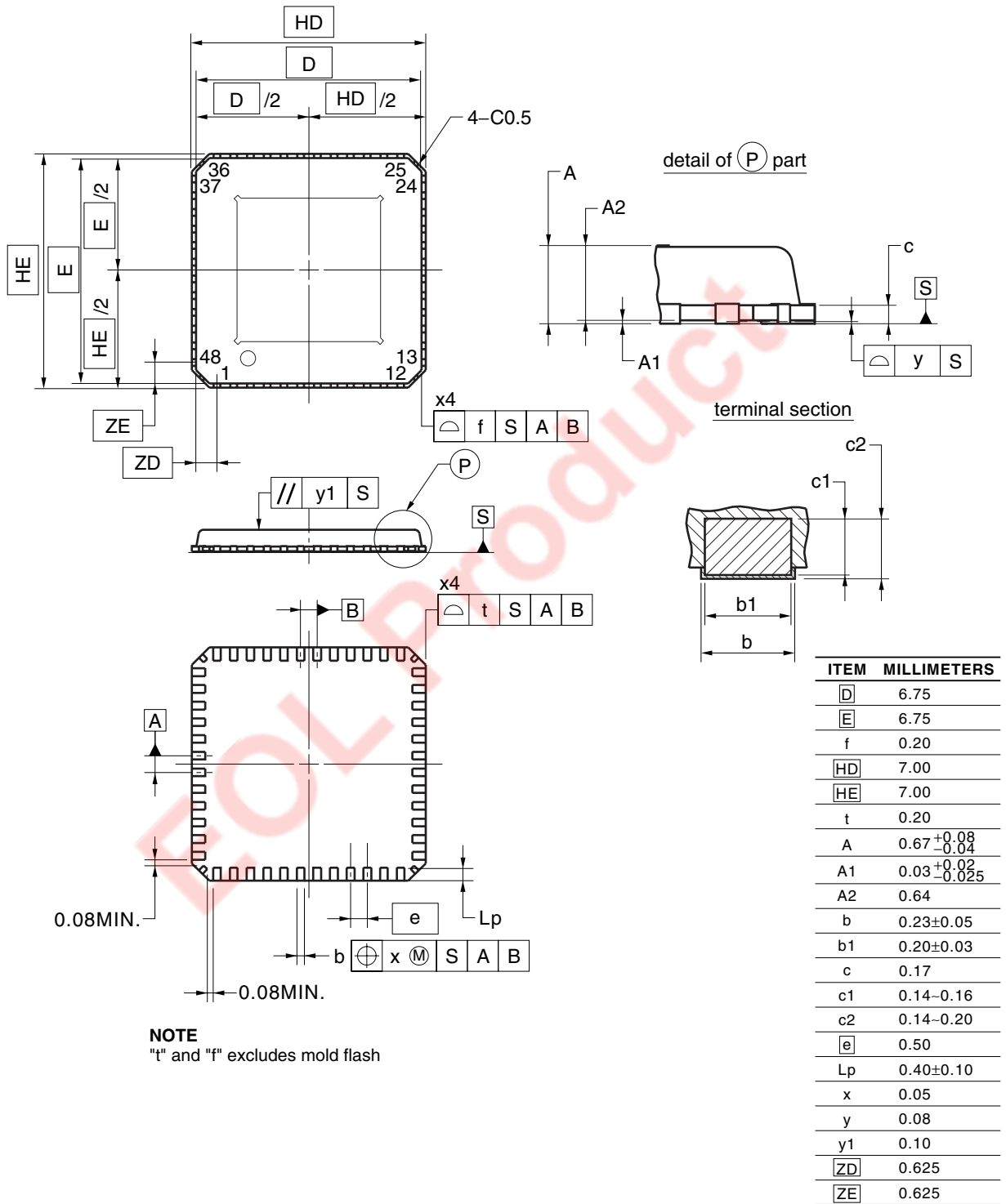

NOTE
"t" and "f" excludes mold flash

P48K9-50-5B4

RECOMMENDED SOLDERING CONDITIONS

The μPD168102 should be soldered and mounted under the following recommended conditions.

For details of the recommended soldering conditions, refer to the document **Semiconductor Device Mounting Technology Manual (C10535E)**. For soldering methods and conditions other than those recommended below, contact an NEC sales representative.

Surface Mounting Type Soldering Conditions

Soldering Method	Soldering Conditions	Recommended Condition Symbol
Infrared reflow	Package peak temperature: 260°C, Time: 60 seconds max. (at 220°C or higher), Count: Three times or less, Exposure limit: 3 days ^{Note} (after that, prebake at 125°C for 10 hours), Flux: Rosin-based flux with low chlorine content (chlorine 0.2 Wt% or below) is recommended	IR60-103-3

Note After opening the dry pack, store it at 25°C or less and 65% RH or less for the allowable storage period.

Caution Do not use different soldering methods together (except for partial heating).

EOL Product

NOTES FOR CMOS DEVICES

① PRECAUTION AGAINST ESD FOR SEMICONDUCTORS

Note:

Strong electric field, when exposed to a MOS device, can cause destruction of the gate oxide and ultimately degrade the device operation. Steps must be taken to stop generation of static electricity as much as possible, and quickly dissipate it once, when it has occurred. Environmental control must be adequate. When it is dry, humidifier should be used. It is recommended to avoid using insulators that easily build static electricity. Semiconductor devices must be stored and transported in an anti-static container, static shielding bag or conductive material. All test and measurement tools including work bench and floor should be grounded. The operator should be grounded using wrist strap. Semiconductor devices must not be touched with bare hands. Similar precautions need to be taken for PW boards with semiconductor devices on it.

② HANDLING OF UNUSED INPUT PINS FOR CMOS

Note:

No connection for CMOS device inputs can be cause of malfunction. If no connection is provided to the input pins, it is possible that an internal input level may be generated due to noise, etc., hence causing malfunction. CMOS devices behave differently than Bipolar or NMOS devices. Input levels of CMOS devices must be fixed high or low by using a pull-up or pull-down circuitry. Each unused pin should be connected to V_{DD} or GND with a resistor, if it is considered to have a possibility of being an output pin. All handling related to the unused pins must be judged device by device and related specifications governing the devices.

③ STATUS BEFORE INITIALIZATION OF MOS DEVICES

Note:

Power-on does not necessarily define initial status of MOS device. Production process of MOS does not define the initial operation status of the device. Immediately after the power source is turned ON, the devices with reset function have not yet been initialized. Hence, power-on does not guarantee out-pin levels, I/O settings or contents of registers. Device is not initialized until the reset signal is received. Reset operation must be executed immediately after power-on for devices having reset function.

- **The information in this document is current as of February, 2002. The information is subject to change without notice. For actual design-in, refer to the latest publications of NEC's data sheets or data books, etc., for the most up-to-date specifications of NEC semiconductor products. Not all products and/or types are available in every country. Please check with an NEC sales representative for availability and additional information.**
 - No part of this document may be copied or reproduced in any form or by any means without prior written consent of NEC. NEC assumes no responsibility for any errors that may appear in this document.
 - NEC does not assume any liability for infringement of patents, copyrights or other intellectual property rights of third parties by or arising from the use of NEC semiconductor products listed in this document or any other liability arising from the use of such products. No license, express, implied or otherwise, is granted under any patents, copyrights or other intellectual property rights of NEC or others.
 - Descriptions of circuits, software and other related information in this document are provided for illustrative purposes in semiconductor product operation and application examples. The incorporation of these circuits, software and information in the design of customer's equipment shall be done under the full responsibility of customer. NEC assumes no responsibility for any losses incurred by customers or third parties arising from the use of these circuits, software and information.
 - While NEC endeavours to enhance the quality, reliability and safety of NEC semiconductor products, customers agree and acknowledge that the possibility of defects thereof cannot be eliminated entirely. To minimize risks of damage to property or injury (including death) to persons arising from defects in NEC semiconductor products, customers must incorporate sufficient safety measures in their design, such as redundancy, fire-containment, and anti-failure features.
 - NEC semiconductor products are classified into the following three quality grades:
"Standard", "Special" and "Specific". The "Specific" quality grade applies only to semiconductor products developed based on a customer-designated "quality assurance program" for a specific application. The recommended applications of a semiconductor product depend on its quality grade, as indicated below. Customers must check the quality grade of each semiconductor product before using it in a particular application.
 - "Standard": Computers, office equipment, communications equipment, test and measurement equipment, audio and visual equipment, home electronic appliances, machine tools, personal electronic equipment and industrial robots
 - "Special": Transportation equipment (automobiles, trains, ships, etc.), traffic control systems, anti-disaster systems, anti-crime systems, safety equipment and medical equipment (not specifically designed for life support)
 - "Specific": Aircraft, aerospace equipment, submersible repeaters, nuclear reactor control systems, life support systems and medical equipment for life support, etc.
- The quality grade of NEC semiconductor products is "Standard" unless otherwise expressly specified in NEC's data sheets or data books, etc. If customers wish to use NEC semiconductor products in applications not intended by NEC, they must contact an NEC sales representative in advance to determine NEC's willingness to support a given application.
- (Note)
- (1) "NEC" as used in this statement means NEC Corporation and also includes its majority-owned subsidiaries.
 - (2) "NEC semiconductor products" means any semiconductor product developed or manufactured by or for NEC (as defined above).