

DSC-644

14-BIT D/S AND D/R CONVERTER LOW-PROFILE INDUSTRY STANDARD

Make sure the next
Card you purchase
has...

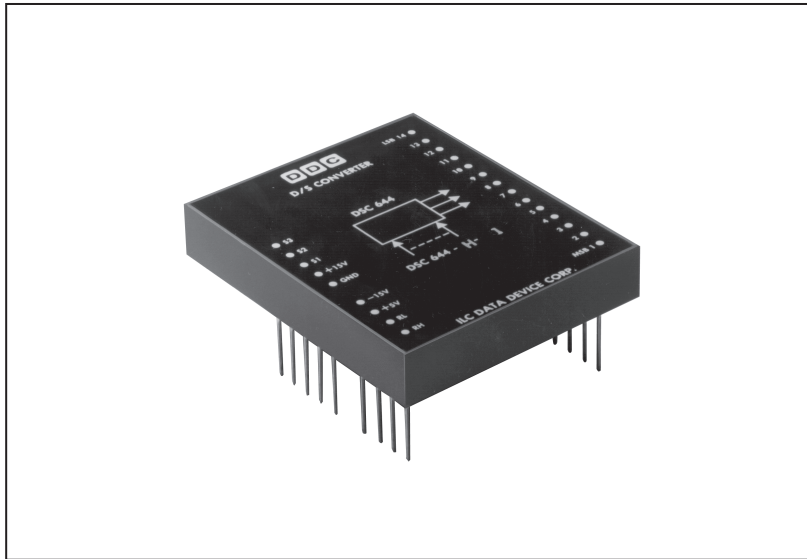

DESCRIPTION

The DSC-644 is a low-profile Digital-to-Synchro (D/S) and Digital-to-Resolver (D/R) converter. It is only 0.52 inches high. The DSC-644 has a standard pin configuration and has a rugged design. The power output stage has overload and transient protection, and a thermal cut-off to prevent overheating. The output has short-circuit protection and an aluminum top plate to improve thermal dissipation. The DSC-644 also has a circuit design that provides a more accurate output with an improved transient response and a negligible scale factor variation. Reliability has also been increased.

The DSC-644 module contains an input reference isolation transformer. An internal output transformer is also included for all 400 Hz versions. The 60 Hz option requires a separate output transformer.

APPLICATIONS

The DSC-644 can be used when digitized shaft angle data must be converted to synchro or resolver form to drive control transformers, control differential transmitters and angle indicators. Because these converters are very rugged and meet the requirements of MIL-STD-202E, they are suitable for the most severe industrial and military applications, including military ground support and avionics. They are ideal for computer-based systems where digital information is processed, such as simulators, flight trainers, flight instrumentation, and fire control systems.



Data Device Corporation
105 Wilbur Place
Bohemia, New York 11716
631-567-5600 Fax: 631-567-7358
www.ddc-web.com

FEATURES

- 1.5 VA Drive Capability
- Protected Output:
 - Rugged Current-Limited Output
 - Short-Circuit Protection
 - Overvoltage Transient Protection
 - Thermal Cutoff
- Metal Heatsink at Top of Case:
 - Conservative Thermal Design
- Very Low Scale Factor Variation:
 - 0.05% Typical
- Output:
 - Internal 400 Hz Isolation Transformer
 - All Common Synchro/Resolver Voltage Levels and Frequencies
- Digital Input:
 - CMOS and TTL Compatible
 - Parallel Binary Angle Input

FOR MORE INFORMATION CONTACT:

Technical Support:
1-800-DDC-5757 ext. 7771

All trademarks are the property of their respective owners.

© 1999 Data Device Corporation

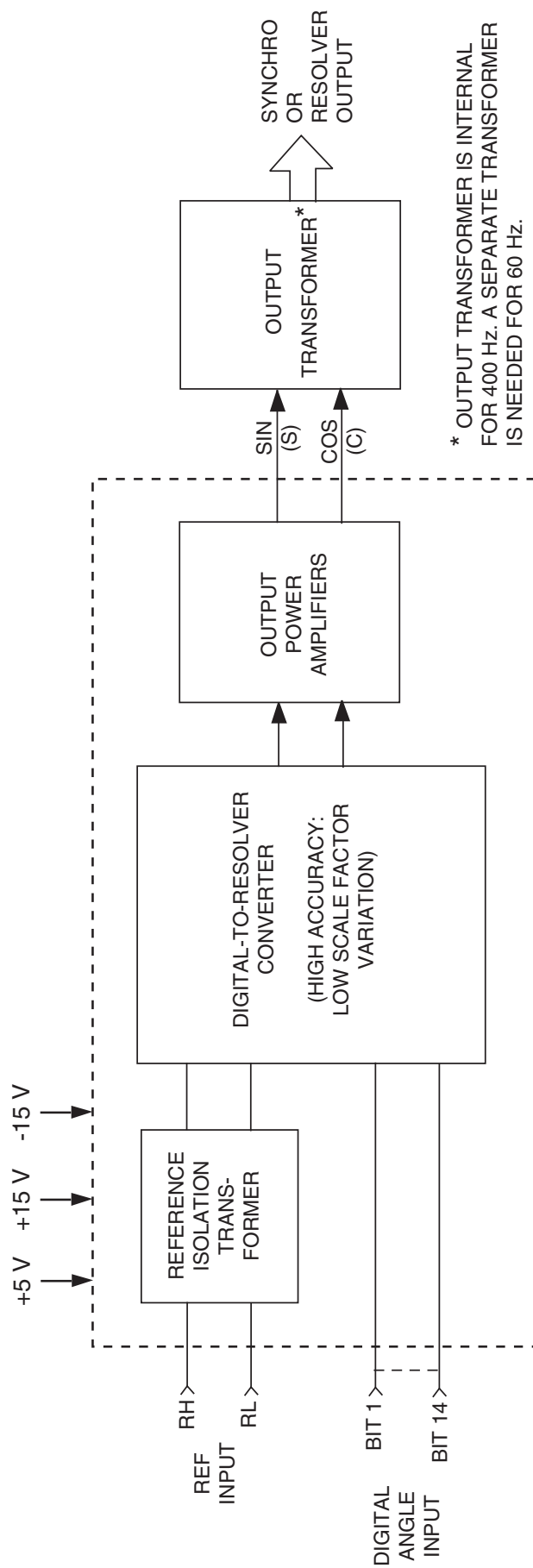

* OUTPUT TRANSFORMER IS INTERNAL FOR 400 Hz. A SEPARATE TRANSFORMER IS NEEDED FOR 60 Hz.

FIGURE 1. DSC-644 BLOCK DIAGRAM

TABLE 1. DSC-644 SPECIFICATIONS

Applies over operating temperatures and frequency ranges, $\pm 5\%$ variation of power supplies, $\pm 10\%$ reference amplitude variation, up to 10% reference harmonic distortion, and for any balanced load up to full load.

PARAMETER	VALUE		
RESOLUTION	14 bits		
ACCURACY (TO FULL LOAD) Output Accuracy Differential Linearity	± 4 minutes ± 1 LSB max.		
DIGITAL INPUT Logic Type	Natural binary angle. parallel positive logic TTL compatible Transient protected CMOS 33 k Ω pull-up to +5V		
Loading	0.13 Std TTL loads		
REFERENCE INPUT (TRANSFORMER-ISOLATED) Units with 90 Vrms L-L Output Units with 11.8 Vrms L-L Output	REFERENCE VOLTAGE LEVEL* 115 Vrms 26 Vrms * +20% absolute max. to avoid damage.	MAX REF. CURRENT 0.6 mA 0.6 mA	REFERENCE IMPEDANCE 191 K Ω 43 K Ω
ANALOG OUTPUT (TRANSFORMER-ISOLATED) Drive Capability (L-L Balanced*) Synchro Output 90 Vrms L-L, 360-440 Hz (Option H) 90 Vrms L-L, 57-440 Hz (Option 6) 11.8 Vrms L-L, 360-440 H (Option L) Resolver Output 11.8 Vrms L-L, 360-440 Hz (Option L) Output Scale Factor Absolute (All Causes) Variation with Digital Angle Output Quadrature	4 k Ω min 4 k Ω min 70 Ω min 93 Ω min $\pm 2\%$ max simultaneous amplitude variation on all output lines, including variation with digital angle. Output amplitude tracks reference input amplitude. $\pm 0.1\%$ max $\pm 0.3\%$ max		
* The output amplifiers will drive loads with any phase angle from -90° to $+90^\circ$			

TABLE 1. DSC-644 SPECIFICATIONS (CON'T)

Applies over operating temperatures and frequency ranges, $\pm 5\%$ variation of power supplies, $\pm 10\%$ reference amplitude variation, up to 10% reference harmonic distortion, and for any balanced load up to full load.

PARAMETER	VALUE		
POWER SUPPLY Voltage Max Voltage without Damage Average Current Peak Current with Normal Load Peak Current at Power Turn-on or Short Circuit	+15V +18V 150mA max 330mA max 600mA max	-15V -18V 150mA max 330mA max 600mA max	+5V +7V 5mA max 5mA max 5mA max
TEMPERATURE RANGES Operating (Temperature of Metal Plate on Top of Case) -1 Option -3 Option Storage θ_{JA}	-55°C to +85°C 0°C to +70°C -55°C to +125°C 48°C/watt		
PHYSICAL CHARACTERISTICS Converter Module (encapsulated) Size Weight 60Hz Transformer Module (encapsulated) Size Weight	3.125 x 2.625 x 0.52 inch (7.94 x 6.67 x 1.32 cm) 5.1 oz max (145 g) 2.25 x 2.25 x 0.81 inch (5.7 x 5.7 x 2.1 cm) 10.5 oz max (298 g)		

TABLE 2. BIT WEIGHT TABLE

BIT	DEG/BIT	MIN/BIT
1 MSB	180	10,800
2	90	5,400
3	45	2,700
4	22.5	1,350
5	11.25	675
6	5.625	337.5
7	2.813	168.75
8	1.406	84.38
9	0.7031	42.19
10	0.3516	21.09
11	0.1758	10.55
12	0.0879	5.27
13	0.0439	2.64
14 LSB	0.0220	1.32

INTRODUCTION

The DSC-644 (see FIGURE 1) contains an internal digital-to-resolver (D/R) converter which has an inherently high accuracy and low scale factor variation. The circuit in the internal D/R converter is based on an algorithm whose theoretical math error is only ± 3.5 arc-seconds (less than 5% of 1 LSB), and whose theoretical scale factor variation with angle is less than $\pm 0.015\%$. The output is well behaved, with negligible glitches at major transition points. The accuracy and scale factor error are now limited by the physical components, not by the algorithm.

The digital inputs are transient protected CMOS switches with 33 k Ω pull up resistors to the +5V supply, and can be driven by all standard TTL gates. If the TTL gates drive other loads as well, the circuit must allow the 33 k Ω resistors to pull up the logic level to within 1.0V of the +5V supply. Bit weights for the 14 binary inputs are given in the bit weight table. The angle is determined by adding bits in the logic 1 state.

The internal reference input transformer provides isolation at both 60 Hz and 400 Hz, so a change of frequency will not cause damage. The input is specified for operation at a reference level of either 115V or 26Vrms. The output signals are proportional to the applied reference, and any distortion in the reference input will appear in the output signals.

The metal top of the converter module should be provided with sufficient air circulation. Refer to Table 1, JA temperature for forced air cooling requirements. Recommended linear air speed of 1 meter/sec for all applications. A thermal cutout disables the output power amplifiers when the internal temperature reaches 125°C. The output is automatically restored when the temperature drops again.

The DSC-644 will not be damaged by any sequencing order or interruptions in either the dc supplies or the reference input. However, if one of the dc supplies is shut down or subsequently powered up, maximum turn on current (450mA) will be drawn from the other 15V supply until the missing 15V supply is restored.

The 60 Hz synchro unit requires both a converter module (DSC-644-6) and a separate transformer because of the transformer size. The output power amplifiers on the -6 module provide a 7Vrms nominal $\pm 2\%$ resolver signal for the external transformer when the reference input is 115Vrms.

Minimum load impedances are listed in the Specifications Table under Drive Capability. The DSC-644 can drive these impedances under the worst case conditions stated in the table. The minimum load impedances correspond to a 1.5VA drive capability when the line voltages and frequencies are at their nominal values.

DDC also manufactures the DSC-544, another D/S converter which provides 60 and 400 Hz 90V L-L synchro output. The DSC-544 is a high efficiency, reference powered converter with a standard 0.82 inch high profile. It does not require $\pm 15V$ power supplies. When driving the same load, the DSC-544 dissipates half as much power as the DSC-644. At 400 Hz the DSC-544 can drive 4.5VA compared to 1.5VA for the DSC-644. Both units can drive 1.5VA at 60 Hz, but the DSC-544 does not require an external transformer at this frequency.

OUTPUT PHASING AND SCALE FACTOR

The analog output signals have phasing as shown in FIGURES 2A and 2B.

The output amplitudes simultaneously track reference voltage fluctuations since they are proportional to RH-RL. The amplitude factor A_0 is 90/115V for 90 Vrms L-L output and 11.8/26V for 11.8 Vrms L-L output. The maximum variation in A_0 from all causes is $\pm 1.9\%$. The term $A(\theta)$ represents the variation of the amplitude with respect to the digital input angle. The scale factor variation, $A(\theta)$, is a smooth function of θ without discontinuities and is less than ± 0.001 for all values of θ . The total maximum variation in $A_0 (1 + A(\theta))$ is therefore $\pm 2\%$. The low value of A_0 allows the DSC-644 to be used to drive systems such as X-Y plotters or CRT displays in which the sin and cos outputs are used independently (not ratiometrically as in a control transformer).

Note: RH & RL ref input is 180° out of phase with modern Synchro/Digital converters per ARINC 407 compliant standard. Swap the RH & RL to the converter to become 407 compliant. Also reference Synchro standards MIL-S-20708.

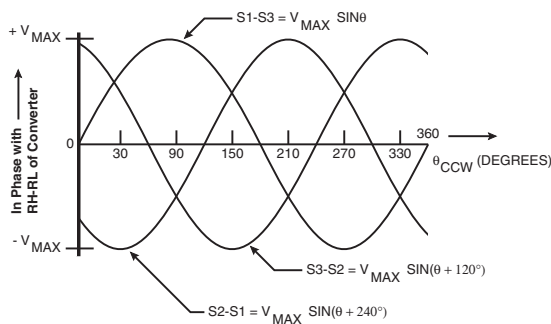

FIGURE 2A. SYNCHRO OUTPUT SIGNALS

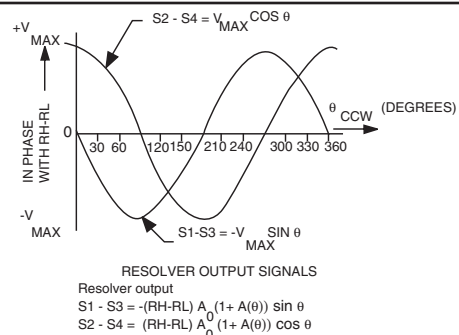

FIGURE 2B. RESOLVER OUTPUT SIGNALS

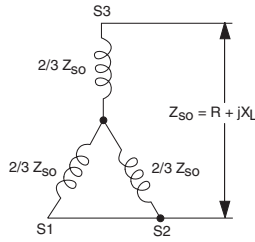

FIGURE 3. Z_{SO} MEASUREMENT

TABLE 3. TYPICAL CONTROL TRANSFORMERS AND THEIR LOAD IMPEDANCES

MILITARY PART NUMBER	SIZE	Z_{SO}
26V 08CT4c	08	100 + j490
26V 11CT4d	11	21 + j132
11CT4e	11	838 + j4955
15CT4c	15	1600 + j9300
15CT6b	15	1170 + j6780
18CT4c	18	1420 + j13260
18CT6b	18	1680 + j5040
23CT4a	23	1460 + j11050
23CT6a	23	1250 + j3980

DRIVING CT LOADS

When driving CT loads the DSC-644 must have enough power drive capability to drive the Z_{SO} of the load. Z_{SO} (stator impedance with rotor open-circuited) is measured as shown in FIGURE 3. TABLE 3 shows the load impedance of some typical control transformers.

Control transformers are highly inductive loads and it is possible to save power by tuning such loads. Three capacitors may be placed across the legs of the synchro stator in a delta configuration:

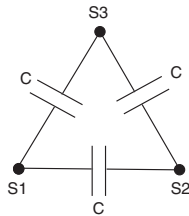

FIGURE 4. DELTA TUNING CONFIGURATION

The correct value of the capacitance in Farads is given by:

$$C = \frac{X_L}{4\pi f (R^2 + X_L^2)}$$

where f is the carrier frequency and R and X_L are the series real and reactive components of Z_{SO} . High grade capacitors must be used and they must be able to withstand the full AC output voltage.

When the load has been tuned more loads can be driven in parallel, because the load impedance is increased to:

$$Z = \frac{R^2 + X_L^2}{R}$$

ACCURACY TESTS

The accuracy of the DSC-644 may be tested with a high accuracy synchro/resolver angle indicator and a load such as a control transformer, as shown in FIGURE 5. The bit switches are set to the desired test angles and the output angle is measured under load. The accuracy should conform to the specifications.

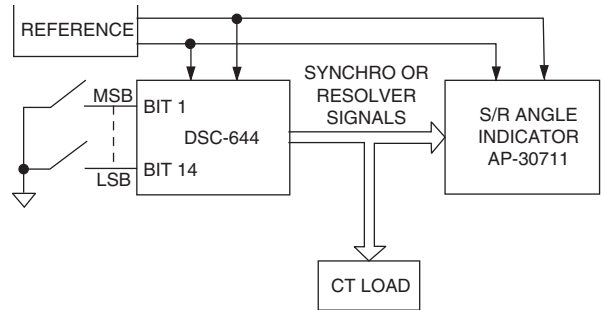

FIGURE 5. ACCURACY TEST CIRCUIT

TEST METHODS

The DSC-644 converter modules are high-quality products. These modules were designed to meet the specific test methods and conditions of MIL-STD-202E (see TABLE 4) unless alternative methods are specified by the customer in the customer's procurement documentation.

PRINTED CIRCUIT BOARD MOUNTING

When mounting a converter on a printed circuit board, it is very important to keep logic level signals as far away from the AC and power signals as possible. Under no circumstances should AC or power pins be adjacent to data pins at the connector. It is also prudent to keep the AC and power pins separated from each other. The intent is to make it impossible to short circuit logic inputs/outputs to AC or power pins with scope probes, etc.

It is strongly recommended that circuit layouts be designed in such a way that plated through-holes are not required when mounting hybrid or discrete modules. If all lands connecting to pins are located on the opposite (DIP) side of the PC board from the module, there will be no risk of destroying a pin connection by ripping out the plated through-hole connection if the module has to be removed. It will also be much easier to unsolder a module without damaging it.

TABLE 4. MIL-STD-202E TEST METHODS

METHOD	CONDITION	COMMENT
204C	C	10G, 2000 Hz vibration
213B	A	50G, 11ms shock
106D*	—	Moisture
107D	A	Thermal shock
101D	B	Salt spray
105C	B	50,000 ft, altitude

* when conformally coated on P.C. board

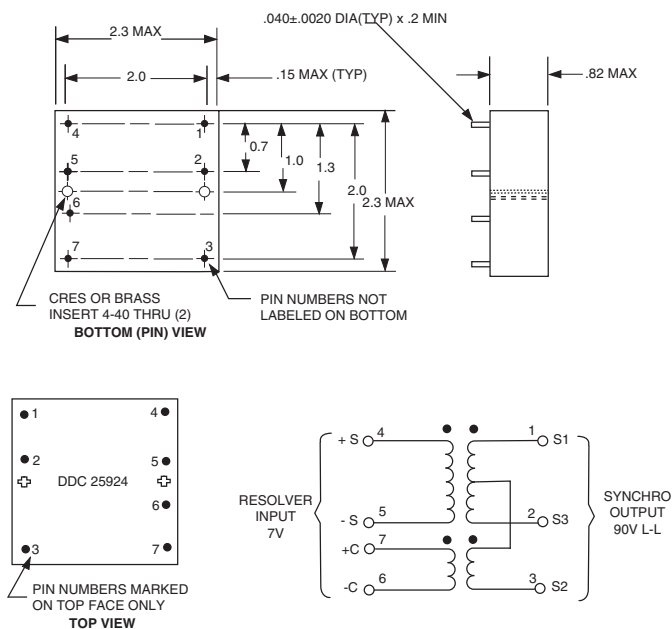

(Dimensions in inches, ±0.01 inch, unless otherwise indicated) Weight = 0.66lbs

TRANSFORMER CONNECTIONS

Transformer Pin Number	Connect To
1	S1 } Synchro Output
2	S3 } 90v L-L
3	S2 } 57-440 Hz
4	SIN } To
5	GND } Converter
6	GND } Module
7	COS }

FIGURE 6. MECHANICAL OUTLINE, 60 HZ EXTERNAL SYNCHRO TRANSFORMER - DDC-25924

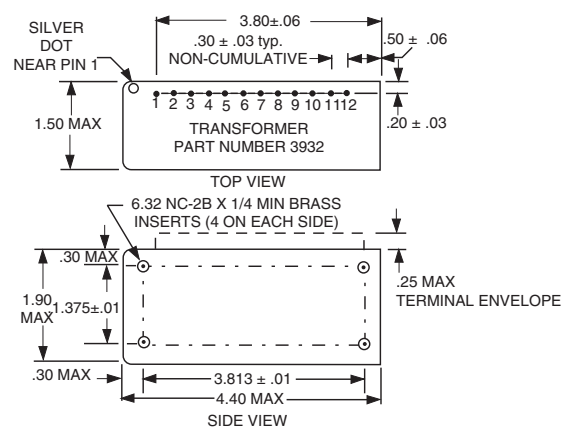

Dimensions are in inches.

TRANSFORMER CONNECTIONS

Transformer Pin Number	Connect To
1	S1 } Synchro Output
2	S3 } 90v rms L-L
3	S2 } 47-440 Hz
4	SIN } To
5	GND } Converter
6	GND } Module
7	COS }
8	RH } Do Not Use
9	RL }
10	+R } Do Not Use
11	RC }
12	-R }

PIN CALL-OUTS SHOWN FOR REFERENCE ONLY.

*For 50Hz applications P/N DDC-3932 must be ordered.

FIGURE 7. MECHANICAL OUTLINE, 50 HZ EXTERNAL SYNCHRO TRANSFORMER - DDC-3932*

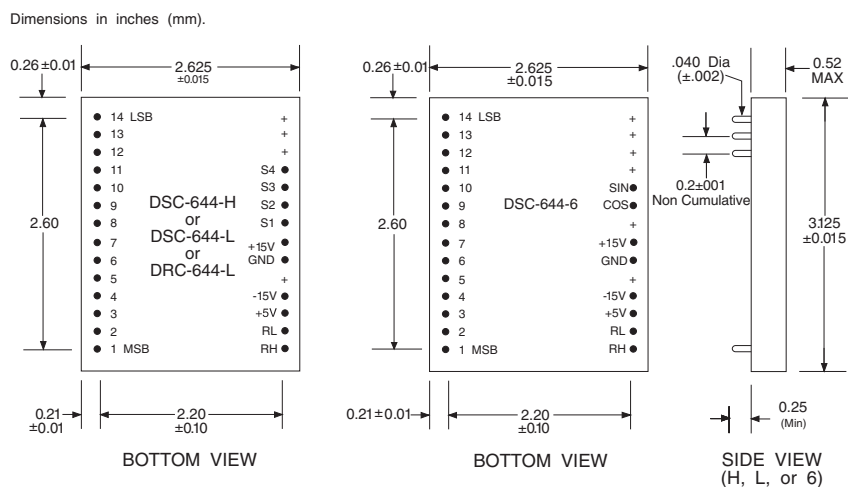

Notes:

- Pin labels on bottom view are for reference only.
- All dimensions shown are in inches.
- Pin material meets solderability requirements of MIL-STD-202E, Method 208C.
- Case material is glass filled Diallyl Phthalate per MIL-M-14, Type SDG-F, except top surface is a black anodized aluminum plate for heat transfer.
- Pin S4 is present on resolver units only.
- Any LSB pins not used should be grounded.

FIGURE 8. DSC-644 MECHANICAL OUTLINE

ORDERING INFORMATION

DXC-644-X-X-X

Reliability

R = Enhanced Reliability* (Only available with -55 to +85°C temperature range option)

Operating Temperature Range of Metal Top

1 = -55°C to +85°C

3 = 0°C to +70°C

Output Voltage Level and Frequency

H = 90 Vrms L-L, 360-440 Hz (Synchro only) (Note 1)

L = 11.8 Vrms L-L, 360-440 Hz (Synchro or Resolver) (Note 1)

6 = 90 Vrms L-L, 47-440 Hz (Synchro only) (Note 2)

Output Type

DSC = Synchro (Valid outputs: H, L, 6)

DRC = Resolver (Valid output: L only)

Notes:

1. 400 Hz units (H and L) have an internal output transformer.
2. 60 Hz units require an external transformer that must be ordered separately as shown below.
For -6 Output Voltage Option:
 - a. For 57-440 Hz applications, either the transformer P/N DDC-3932 or DDC-25924 may be used.
 - b. For 47-440 Hz applications, transformer P/N DDC-3932 must be used. Reference pins should not be connected.
3. Available Sockets:
P/N 9010 Socket to barrel ends (Barrel ends can be soldered to)
P/N 9046 Socket to pins ends (Can be soldered into PCB)
P/N 9050 Socket to wire wrap ends
4. These products contain tin-lead solder.

**R" option only available in -55°C to +85°C temperature range (Option "1"). Enhanced Reliability processing provides an 85°C burn-in.

STANDARD DDC PROCESSING FOR DISCRETE MODULES/PC BOARD ASSEMBLIES		
TEST	METHOD(S)	CONDITION(S)
INSPECTION / WORKMANSHIP	IPC-A-610	Class 3
ELECTRICAL TEST	DDC ATP	—

The information in this data sheet is believed to be accurate; however, no responsibility is assumed by Data Device Corporation for its use, and no license or rights are granted by implication or otherwise in connection therewith.
Specifications are subject to change without notice.

Please visit our web site at www.ddc-web.com for the latest information.



105 Wilbur Place, Bohemia, New York, U.S.A. 11716-2426

For Technical Support - 1-800-DDC-5757 ext. 7771

Headquarters, N.Y., U.S.A. - Tel: (631) 567-5600, Fax: (631) 567-7358

United Kingdom - Tel: +44-(0)1635-811140, Fax: +44-(0)1635-32264

France - Tel: +33-(0)1-41-16-3424, Fax: +33-(0)1-41-16-3425

Germany - Tel: +49-(0)89-15 00 12-11, Fax: +49-(0)89-15 00 12-22

Japan - Tel: +81-(0)3-3814-7688, Fax: +81-(0)3-3814-7689

Asia - Tel: +65-6489-4801

World Wide Web - <http://www.ddc-web.com>



DATA DEVICE CORPORATION
REGISTERED TO:
ISO 9001:2008, AS9100C:2009-01
EN9100:2009, IFS Q9100:2009
FILE NO. 10001296 ASH09