

Preliminary

CS1088

Vacuum Fluorescent Display Tube Driver

Description

The VFD Driver is a microprocessor interface IC that drives a multiplexed VF (Vacuum Fluorescent) display tube. It consists of a 34-bit shift register, a 34-bit transparent data latch, a metal mask ROM, six 20mA anode output drivers, twenty-five 2mA anode output drivers,

and three 50mA grid drivers with output enables. The metal mask programmable ROM (at factory request) allows the 31 anode outputs and 3 grid outputs to be assigned to any of the 34 serial data bits.

Absolute Maximum Ratings

Supply Voltage (V_{BB})	-0.6V to 18.0V
Input Voltages (D_{IN} , CLK, STB, GREN)	-0.6V to 6.0V
Junction Temperature Range	-40°C to 150°C
Storage Temperature Range	-55°C to 150°C
ESD Susceptibility (Human Body Model)	2kV
ESD Susceptibility (Machine Model)	200V
Lead Temperature Soldering		
Wave Solder (through hole styles only)	10 sec. max, 260°C peak
Reflow (SMD styles only)	60 sec. max above 183°C, 230°C peak

Application Diagram

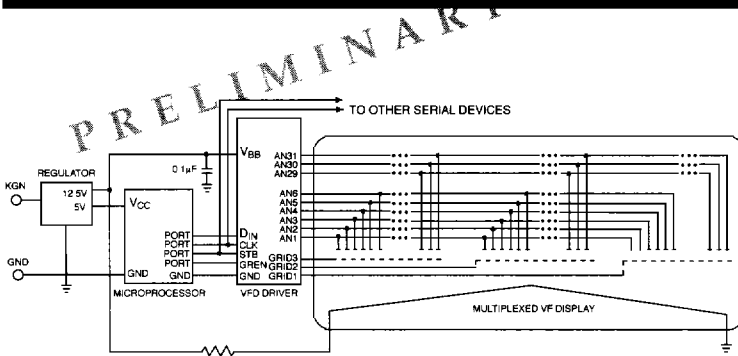

Features

Package Options

40 Lead PDIP



44 Lead PLCC

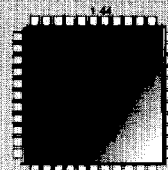

48 Lead LQFP

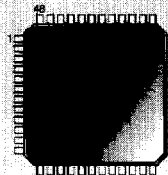

Cherry Semiconductor Corporation
 2000 South County Trail, East Greenwich, RI 02818
 Tel: (401)885-3600 Fax: (401)885-5786
 Email: info@cherry-semi.com
 Web Site: www.cherry-semi.com

Electrical Characteristics: $8.0V < V_{BB} < 16.5V$, $Gnd = 0V$, $-40^{\circ}C < T_A < 105^{\circ}C$
 the sign (+ or -) refers to the direction of the current (positive current goes into the lead); unless otherwise stated

PARAMETER	TEST CONDITIONS	MIN	TYP	MAX	UNIT
■ V_{BB} Input					
V _{BB} input voltage		8.0		16.5	V
I _{BBO} Current	No outputs active, V _{BB} = 16.5V		2	5	mA
Reset Mode	All outputs forced low.		6.5	7.5	V
■ DIN, CLK, STB Inputs					
V _{IL} input low voltage				1.6	V
V _{IH} input high voltage		3.3			V
I _{IL} input current	V _{IN} = V _{IH}	0	7.5	20.0	μA
■ GREN Input					
V _{IL} input low voltage				1.6	V
V _{IH} input high voltage		3.3			V
I _{IH} input pull-down current	V _{IN} = 3.325V		30	60	μA
■ GRID1, GRID2, GRID3 Outputs					
I _{OL}	Sink Current	1.0			mA
I _{OH}	Source Current	50			mA
V _{OL}	I _{OUT} = 1mA			0.5	V
V _{OH}	I _{OUT} = -50mA, V _{BB} = 12V	V _{BB} - 0.75		V _{BB}	V
■ AN24-AN29 Outputs					
I _{OL}	Sink Current	400			μA
I _{OH}	Source Current	20			mA
V _{OL}	I _{OUT} = 400μA			0.5	V
V _{OH}	I _{OUT} = -20mA	V _{BB} - 0.5		V _{BB}	V
■ AN1-AN23, AN30-AN31 Outputs					
I _{OL}		100			μA
I _{OH}		20			mA
V _{OL}	I _{OUT} = 100μA			0.5	V
V _{OG}	I _{OUT} = -2mA	V _{BB} - 0.5		V _{BB}	V
■ AC characteristics: Input and output timing					
F _C CLK Frequency		0		2.0	MHz
T _{CL} CLK low time		200			ns
T _{CH} CLK high time		200			ns
T _{CR} CLK rise time				100	ns
T _{CF} CLK fall time				100	ns
T _{SC} STB low to CLK high time		50			ns
T _{ST} STB high time		500			ns
T _{AN} STB high to anode output propagation delay				5.0	μs

Electrical Characteristics: $V_{DD} = 8.0V$, $V_{BB} = 16.5V$, $Gnd = 0V$, $-40^{\circ}C < T_A < 105^{\circ}C$.
 The sign (+ or -) refers to the direction of the current (positive current goes into the lead); unless otherwise stated.

PARAMETER	TEST CONDITIONS	MIN	TYP	MAX	UNIT
■ AC characteristics: Input and output timing: continued					
T_{GL} , grid turn on propagation delay	$V_{BB} = 12V$			2	μs
T_{GO} , grid turn off propagation delay	$V_{BB} = 12V$			5	μs
T_{GR} , grid rise time	At rated load.	0.5		5.0	μs
T_{GF} , grid fall time	At rated load.	0.5		5.0	μs
T_{AR} , anode rise time	At rated load.	0.5		5.0	μs
T_{AF} , anode fall time	At rated load.	0.5		5.0	μs

Note: Grid and anode rise/fall times are measured from 10% and 90% points.

Output currents are at the maximum rated currents for the respective stages.

Package Lead Description

PACKAGE LEAD #			LEAD SYMBOL	FUNCTION
40L DIP	44L PLCC	48L LQFP	(31 Anode Configuration)	
1	14	8	GRID1	50mA grid output.
2	15	9	GRID2	50mA grid output.
3	16	10	GRID3	50mA grid output.
4	17	11	AN1	2mA anode output.
5	18	13	AN2	2mA anode output.
6	19	14	AN3	2mA anode output.
7	20	15	AN4	2mA anode output.
8	21	16	AN5	2mA anode output.
9	22	17	AN6	2mA anode output.
10	24	19	AN7	2mA anode output.
11	25	20	AN8	2mA anode output.
12	26	21	AN9	2mA anode output.
13	27	22	AN10	2mA anode output.
14	28	23	AN11	2mA anode output.
15	29	25	AN12	2mA anode output.
16	30	26	AN13	2mA anode output.
17	31	27	AN14	2mA anode output.
18	32	28	AN15	2mA anode output.
19	33	29	AN16	2mA anode output.
20	35	31	Gnd	Ground connection.
21	36	32	AN17	2mA anode output.
22	37	33	AN18	2mA anode output.
23	38	34	AN19	2mA anode output.
24	39	35	AN20	2mA anode output.

Package Lead Description: continued

PACKAGE LEAD #			LEAD SYMBOL	FUNCTION
40L DIP	44L PLCC	48L LQFP	(31 Anode Configuration)	
25	40	37	AN21	2mA anode output.
26	41	38	AN22	2mA anode output.
27	42	39	AN23	2mA anode output.
28	43	40	AN24	20mA anode output.
29	44	41	AN25	20mA anode output.
30	2	43	AN26	20mA anode output.
31	3	44	AN27	20mA anode output.
32	4	45	AN28	20mA anode output.
33	5	46	AN29	20mA anode output.
34	6	47	AN30	2mA anode output.
35	7	1	D _{IN}	Shift register data input.
36	8	2	CLK	Shift register clock input.
37	9	3	STB	Transfer contents of shift registers to output stages.
38	10	4	GREN	Grid outputs enable.
39	11	5	AN31	2mA anode output.
40	13	7	V _{BB}	Supply voltage input.
	1, 12, 23, 34	6, 12, 18, 24 30, 36, 42, 48	NC	No connection.

Operation Description

Upon the initial application of power, the power on reset function will cause all of the anode and grid driver outputs to be off and all shift register outputs to be set low. Data is fed into the shift register through the D_{IN} pin at the rising edge of the CLK input. Thirty four bits of data are capable of being stored by the shift register. Once the desired pattern is stored in the shift register, it can be transferred to the latch by setting the STB input high. The output of each latch drives its corresponding output stage. A logic high input to the shift register/latch will cause the corresponding output to turn on. A logic low input to the shift

register /latch will cause the corresponding output to turn off. Please note that if the STB is held high, the outputs of the latch reflect the outputs of the corresponding shift register bits and will change if data is shifted in.

The three GRID outputs are gated by the GREN input. When GREN is low, the GRID outputs are forced low regardless of the state of the corresponding latch output. When GREN is high, the GRID outputs correspond to the state of their respective latch outputs. The anode outputs, AN1 to AN31, are always enabled.

Block Diagram

CS1088

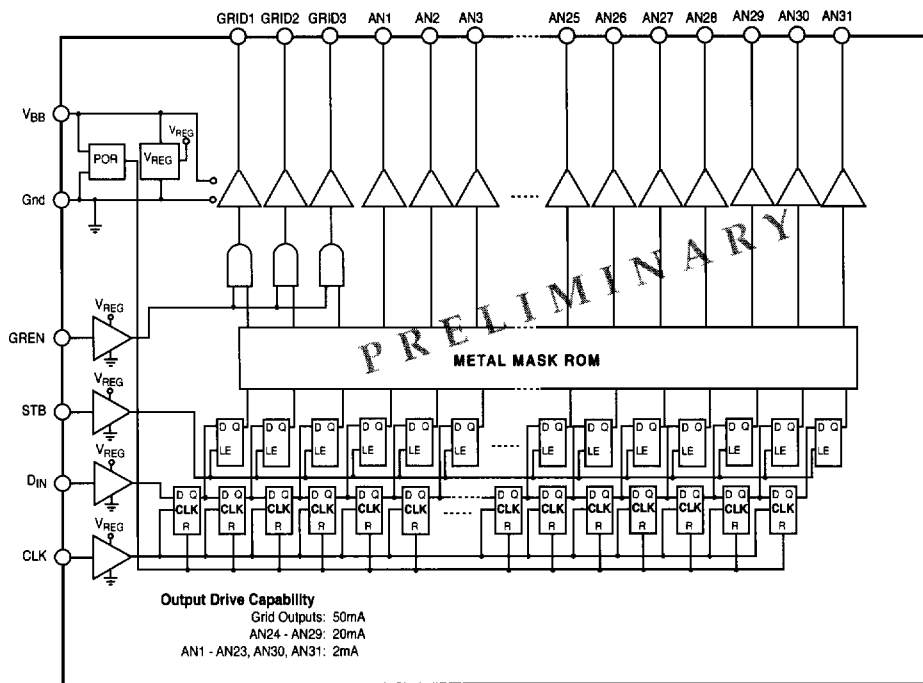

Application Information

Bit #	1	2	3	4	5	6	7	8	9	10	11	12	13	14	15	16	17
Pin Name	G1	G2	G3	A1	A2	A3	A4	A5	A6	A7	A8	A9	A10	A11	A12	A13	A14
Bit #	18	19	20	21	22	23	24	25	26	27	28	29	30	31	32	33	34
Pin Name	A15	A16	A17	A18	A19	A20	A21	A22	A23	A24	A25	A26	A27	A28	A29	A30	A31

Table 1: Bit Pattern, G = Grid, A = Anode.

Typical Operation

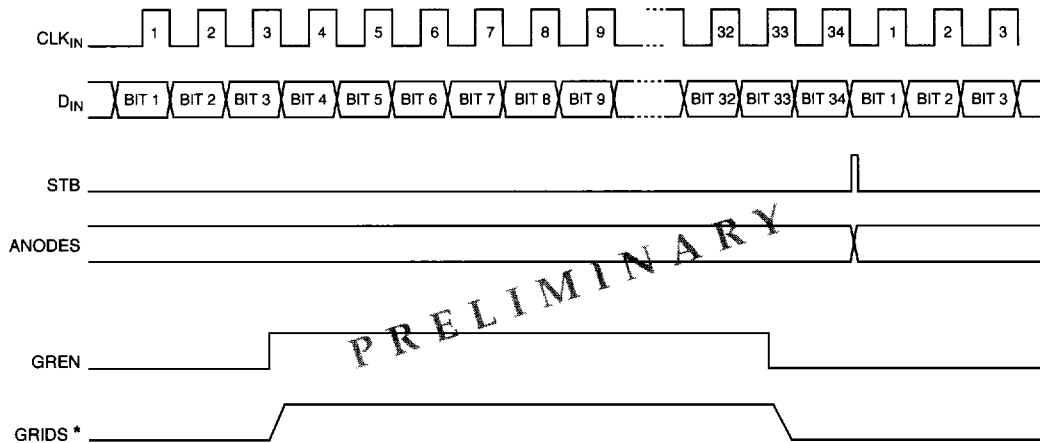

* Selected grid goes high only if input bit pattern from shift register to grid is high.

PACKAGE DIMENSIONS IN mm (INCHES)

Lead Count	D			
	Metric		English	
	Max	Min	Max	Min
40L PDIP	50.3	53.2	1.980	2.095

Lead Count	A		B		A		B	
	Metric				English			
	Max	Min	Max	Min	Max	Min	Max	Min
44L PLCC	17.65	17.40	16.66	16.51	.695	.685	.656	.650

PACKAGE THERMAL DATA

Thermal Data		40L PDIP	44L PLCC	48L LQFP	
R _{θJC}	typ	20	16	-	°C/W
R _{θJA}	typ	45	55	-	°C/W

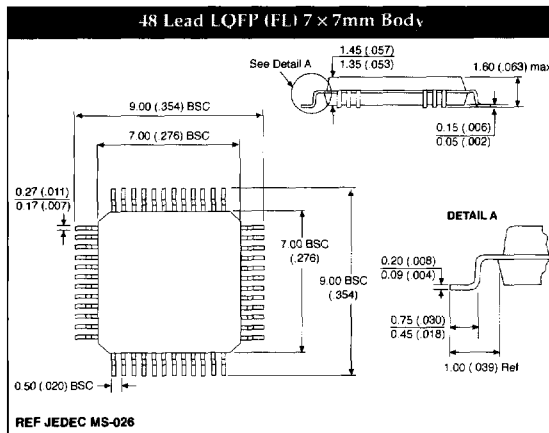
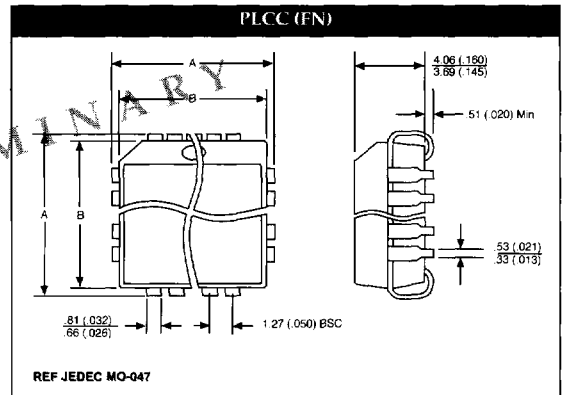
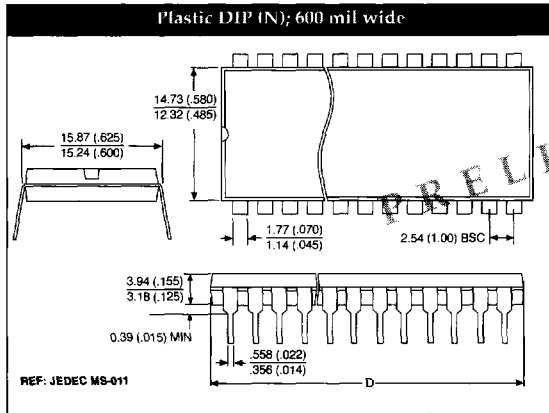

Ordering Information

Part Number	Description
CS1088XN40	40 Lead PDIP
CS1088XFN44	44 Lead PLCC
CS1088XFN44	44 Lead PLCC (tape & reel)
CS1088XFL48	48 Lead LQFP
CS1088XFL48	48 Lead LQFP (tape & reel)

Preliminary

This product is in the preproduction stages of the design process. The data sheet contains preliminary data. Cherry Semiconductor Corporation reserves the right to make changes to the specifications without notice. Please contact Cherry Semiconductor Corporation for the latest available information.