

# SMT CURRENT SENSE TRANSFORMERS

## Low Primary DCR



Ruggedized

- ⊗ Height: 5.5mm Max
- ⊗ Footprint: 8.4mm x 7.2mm Max
- ⊗ Current Rating: up to 20A
- ⊗ Frequency Range: 50kHz to 1MHz
- ⊗ Surface Mount Package - Pick and Place Compatible
- ⊗ Varnished Windings
- ⊗ Ambient Operating Temperature: -55°C to +130°C
- ⊗ Storage Temperature: -55°C to +130°C

- ⊗ Isolation Voltage: 1000Vrms Max
- ⊗ Moisture Sensitivity Level: 1
- ⊗ Solder Reflow Processing: 235°C peak temperature
- ⊗ Lead Finish: Hot Solder Dipped: Sn63%/Pb37%
- ⊗ Meets Environmental Requirements: MIL-PRF-27F Grade 5 Class
- ⊗ Space Grade versions that meet workmanship IAW MIL-STD-981 are available on special request
- ⊗ Low Primary DCR

### Electrical Specifications @ 25°C — Operating Temperature -55°C to +130°C

Part <sup>5,6</sup> Number	Turns Ratio	Current <sup>2</sup> Rating (A)	Secondary Inductance (mH MIN)	DCR (mΩ MAX)		Hipot (V <sub>RMS</sub> )
				Primary (8-7)	Secondary (1-3)	
PL3258	1:20	20	0.08	0.75	550	1000
PL3259	1:30	20	0.18	0.75	870	1000
PL3260	1:40	20	0.32	0.75	1140	1000
PL3261	1:50	20	0.50	0.75	1500	1000
PL3262	1:60	20	0.72	0.75	2500	1000
PL3263	1:70	20	0.98	0.75	4750	1000
PL3264	1:100	20	2.00	0.75	6000	1000
PL3265	1:125	20	3.00	0.75	7700	700
PL3479	1:200	20	8.00	0.75	17000	700

**NOTES:**

1. The temperature of the component (ambient temperature plus temperature rise) must be within the specified operating temperature range.
2. The maximum current rating is based upon temperature rise of the component and represents the dc current which will cause a typical temperature rise of 40°C with no air flow.
3. To calculate the value of the terminating resistor (Rt) use the following formula:  $R_t (W) = V_{REF} * N / (I_{peak\_primary})$
4. The peak flux density of the device must remain below 2000 Gauss. To calculate the peak flux density for a uni-polar current use the following formula:  
 $B_{PK} = 37.59 * V_{REF} * (Duty\_Cycle\_Max) * 10^5 / (N * Freq\_kHz)$   
 \* for bi-polar current applications divide B<sub>PK</sub> as calculated above by 2.
5. Optional Tape & Reel packaging can be ordered by adding a "T" suffix to the part number (i.e. PL3258 becomes PL3258T). Pulse complies to industry standard tape and reel specifications EIA481.
6. The "NL" suffix indicates an RoHS-compliant part number.



# SMT CURRENT SENSE TRANSFORMERS

## Low Primary DCR



Ruggedized

Mechanical

Schematic

PL325X

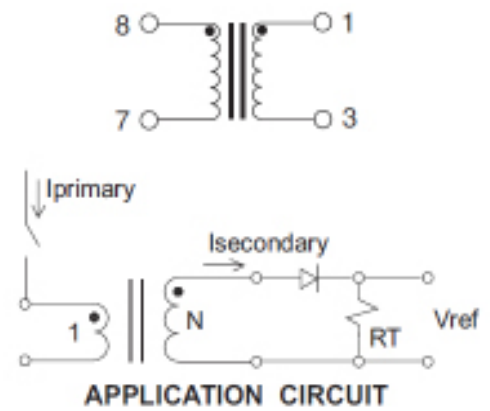
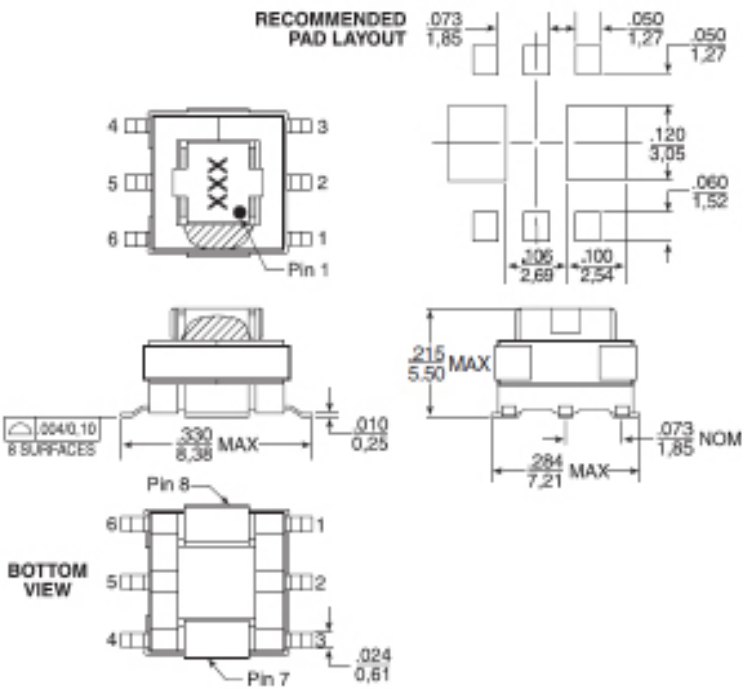

Weight ..... 0.34 grams  
 Tray ..... 120/tray  
 Tape & Reel ..... 900/reel  
 Coplanarity ..... 0.004 inches

Dimensions:  $\frac{\text{Inches}}{\text{mm}}$

Unless otherwise specified, all tolerances are  $\pm \frac{.010}{.025}$



# SMT CURRENT SENSE TRANSFORMERS

## Low Primary DCR



Ruggedized

### Transceiver Tin/Lead Recommended Reflow Profile (Based on J-STD-020D)

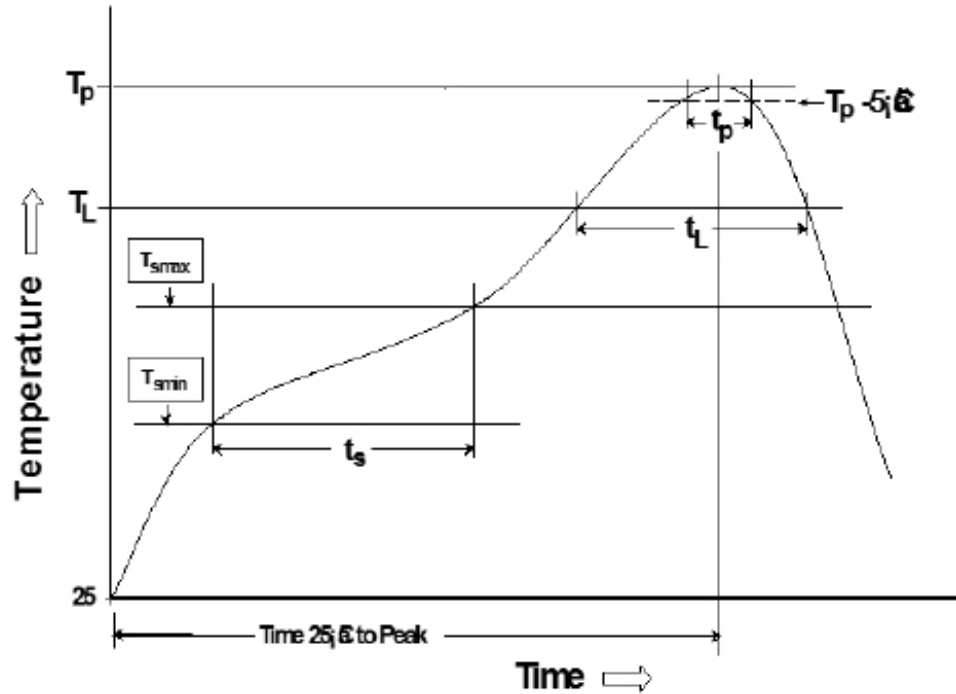

$T_{SMIN}$ (°C)	$T_{SMAX}$ (°C)	$T_L$ (°C)	$T_P$ (°C MAX)	$t_s$ (s)	$t_L$ (s)	$t_p$ (s MAX)	Ramp-up rate ( $T_L$ to $T_P$ )	Ramp-down rate ( $T_P$ to $T_L$ )	Time 25°C to peak temperature (s MAX)
100	150	183	225	60-120	60-150	20	3°C/s MAX	6°C/s MAX	360

Notes:

1. All temperatures measured on the package leads.
2. Maximum times of reflow cycle: 2.

### For More Information

iNRCORE, LLC  
 311 Sinclair Road Bristol,  
 PA 19007-6812 U.S.A  
 Tel: + 1.215.781.6400  
 Fax: +1.215.7816430

**Global Sales Representatives and Locations:**  
<http://www.inrcore.com>

Performance warranty of products offered on this data sheet is limited to the parameters specified. Data is subject to change without notice. Other brand and product names mentioned herein may be trademarks or registered trademarks of their respective owners. © Copyright, 2020. iNRCORE, LLC. All rights reserved.



# Mouser Electronics

Authorized Distributor

Click to View Pricing, Inventory, Delivery & Lifecycle Information:

[iNRCORE:](#)

[PL3479](#) [PL3479T](#)