

100328

Low Power Octal ECL/TTL Bi-Directional Translator with Latch

General Description

The 100328 is an octal latched bi-directional translator designed to convert TTL logic levels to 100K ECL logic levels and vice versa. The direction of this translation is determined by the DIR input. A LOW on the output enable input (OE) holds the ECL outputs in a cut-off state and the TTL outputs at a high impedance level. A HIGH on the latch enable input (LE) latches the data at both inputs even though only one output is enabled at the time. A LOW on LE makes the 100328 transparent.

The cut-off state is designed to be more negative than a normal ECL LOW level. This allows the output emitter-followers to turn off when the termination supply is $-2.0V$, presenting a high impedance to the data bus. This high impedance reduces termination power and prevents loss of low state noise margin when several loads share the bus.

The 100328 is designed with FAST[®] TTL output buffers, featuring optimal DC drive and capable of quickly charging and discharging highly capacitive loads. All inputs have 50 k Ω pull-down resistors.

Features

- Identical performance to the 100128 at 50% of the supply current
- Bi-directional translation
- 2000V ESD protection
- Latched outputs
- FAST TTL outputs
- TRI-STATE[®] outputs
- Voltage compensated operating range = $-4.2V$ to $-5.7V$
- Available to MIL-STD-883

Logic Symbol

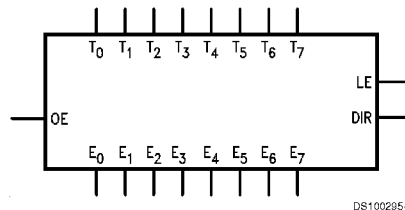

Pin Names	Description
E ₀ -E ₇	ECL Data I/O
T ₀ -T ₇	TTL Data I/O
OE	Output Enable Input
LE	Latch Enable Input
DIR	Direction Control Input

All pins function at 100K ECL levels except for T₀-T₇.

TRI-STATE[®] is a registered trademark of National Semiconductor Corporation.
FAST[®] is a registered trademark of Fairchild Semiconductor.

Connection Diagrams

24-Pin DIP

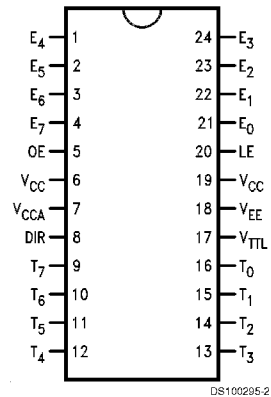

24-Pin Quad Cerpak

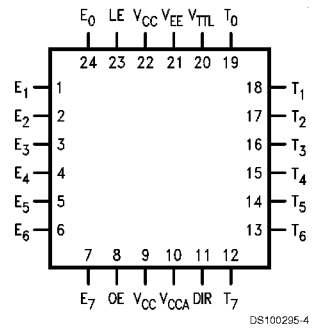

Functional Diagram

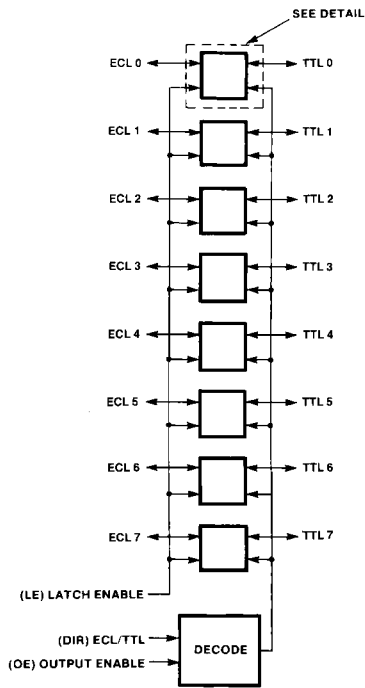

DS100295-5

Note: LE, DIR, and OE use ECL logic levels

Detail

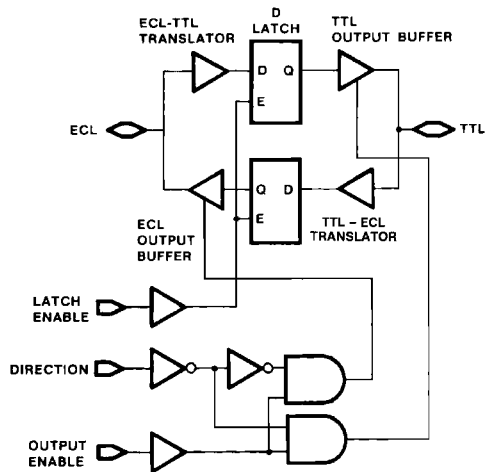

DS100295-6

Truth Table

OE	DIR	LE	ECL Port	TTL Port	Notes
L	X	L	LOW (Cut-Off)	Z	
L	L	H	Input	Z	(Notes 1, 3)
L	H	H	LOW (Cut-Off)	Input	(Notes 2, 3)
H	L	L	L	L	(Notes 1, 4)
H	L	L	H	H	(Notes 1, 4)
H	L	H	X	Latched	(Notes 1, 3)
H	H	L	L	L	(Notes 2, 4)
H	H	L	H	H	(Notes 2, 4)
H	H	H	Latched	X	(Notes 2, 4)

H = HIGH Voltage Level

L = LOW Voltage Level

X = Don't Care

Z = High Impedance

Note 1: ECL input to TTL output mode.

Note 2: TTL input to ECL output mode.

Note 3: Retains data present before LE set HIGH.

Note 4: Latch is transparent.

Absolute Maximum Ratings (Note 5)

If Military/Aerospace specified devices are required, please contact the National Semiconductor Sales Office/Distributors for availability and specifications.

Storage Temperature (T_{STG})	-65°C to +150°C
Maximum Junction Temperature (T_J)	
Ceramic	+175°C
V_{EE} Pin Potential to Ground Pin	-7.0V to +0.5V
V_{TTL} Pin Potential to Ground Pin	-0.5V to +6.0V
ECL Input Voltage (DC)	V_{EE} to +0.5V
ECL Output Current (DC Output HIGH)	-50 mA
TTL Input Voltage (Note 7)	-0.5V to +6.0V
TTL Input Current (Note 7)	-30 mA to +5.0 mA

Voltage Applied to Output in HIGH State

TRI-STATE Output	-0.5V to +5.5V
Current Applied to TTL	
Output in LOW State (Max)	Twice the Rated I_{OL} (mA)
ESD (Note 6)	$\geq 2000V$

Recommended Operating Conditions

Case Temperature (T_C)	
Military	-55°C to +125°C
ECL Supply Voltage (V_{EE})	-5.7V to -4.2V
TTL Supply Voltage (V_{TTL})	+4.5V to +5.5V

Note 5: Absolute maximum ratings are those values beyond which the device may be damaged or have its useful life impaired. Functional operation under these conditions is not implied.

Note 6: ESD testing conforms to MIL-STD-883, Method 3015.

Note 7: Either voltage limit or current limit is sufficient to protect inputs.

Military Version

TTL-to-ECL DC Electrical Characteristics

$V_{EE} = -4.2V$ to $-5.7V$, $V_{CC} = V_{CCA} = GND$, $T_C = -55^\circ C$ to $+125^\circ C$, $V_{TTL} = +4.5V$ to $+5.5V$

Symbol	Parameter	Min	Max	Units	T_C	Conditions	Notes	
V_{OH}	Output HIGH Voltage	-1025	-870	mV	0°C to +125°C	$V_{IN} = V_{IH}$ (Max) or V_{IL} (Min)	Loading with 50Ω to -2.0V	(Notes 8, 9, 10)
		-1085	-870	mV	-55°C			
V_{OL}	Output LOW Voltage	-1830	-1620	mV	0°C to +125°C	OE or DIR Low		
		-1830	-1555	mV	-55°C			
	Cutoff Voltage		-1950	mV	0°C to +125°C			
			-1850	mV	-55°C			
V_{OHC}	Output HIGH Voltage	-1035		mV	0°C to +125°C	$V_{IN} = V_{IH}$ (Min) or V_{IL} (Max)	Loading with 50Ω to -2.0V	(Notes 8, 9, 10)
		-1085		mV	-55°C			
V_{OLC}	Output LOW Voltage		-1610	mV	0°C to +125°C			
			-1555	mV	-55°C			
V_{IH}	Input HIGH Voltage	2.0		V	-55°C to +125°C	Over V_{TTL} , V_{EE} , T_C Range	(Notes 8, 9, 10, 11)	
V_{IL}	Input LOW Voltage		0.8	V	-55°C to +125°C	Over V_{TTL} , V_{EE} , T_C Range	(Notes 8, 9, 10, 11)	
I_{IH}	Input HIGH Current		70	μA	-55°C to 125°C	$V_{IN} = +2.7V$	(Notes 8, 9, 10)	
	Breakdown Test		1.0	mA	-55°C to +125°C	$V_{IN} = +5.5V$		
I_{IL}	Input LOW Current	-1.0		mA	-55°C to +125°C	$V_{IN} = +0.5V$	(Notes 8, 9, 10)	
V_{FCD}	Input Clamp Diode Voltage	-1.2		V	-55°C to +125°C	$I_{IN} = -18$ mA	(Notes 8, 9, 10)	
I_{EE}	V_{EE} Supply Current				-55°C to +125°C	LE Low, OE and DIR High	(Notes 8, 9, 10)	
						Inputs Open		
		-165	-73	mA		$V_{EE} = -4.2V$ to $-4.8V$		
		-175	-73	mA		$V_{EE} = -4.2V$ to $-5.7V$		

Military Version ECL-to-TTL DC Electrical Characteristics

$V_{EE} = -4.2V$ to $-5.7V$, $V_{CC} = V_{CCA} = GND$, $T_C = -55^\circ C$ to $+125^\circ C$, $C_L = 50$ pF, $V_{TTL} = +4.5V$ to $+5.5V$

Symbol	Parameter	Min	Max	Units	T_C	Conditions	Notes
V_{OH}	Output HIGH Voltage	2.5 2.4		mV	$0^\circ C$ to $+125^\circ C$ $-55^\circ C$	$I_{OH} = -1$ mA, $V_{TTL} = 4.50V$	(Notes 8, 9, 10)
V_{OL}	Output LOW Voltage		0.5	mV	$-55^\circ C$ $+125^\circ C$	$I_{OL} = 24$ mA, $V_{TTL} = 4.50V$	
V_{IH}	Input HIGH Voltage	-1165	-870	mV	$-55^\circ C$ $+125^\circ C$	Guaranteed HIGH Signal for All Inputs	(Notes 8, 9, 10, 11)
V_{IL}	Input LOW Voltage	-1830	-1475	mV	$-55^\circ C$ to $+125^\circ C$	Guaranteed LOW Signal for All Inputs	(Notes 8, 9, 10, 11)
I_{IH}	Input HIGH Current		350 500	μA	$0^\circ C$ to $+125^\circ C$	$V_{EE} = -5.7V$ $V_{IN} = V_{IH}$ (Max)	(Notes 8, 9, 10)
I_{IL}	Input LOW Current	0.50		μA	$-55^\circ C$ to $+125^\circ C$	$V_{EE} = -4.2V$ $V_{IN} = V_{IL}$ (Min)	(Notes 8, 9, 10)
I_{OZHT}	TRI-STATE Current Output High		70	μA	$-55^\circ C$ to $+125^\circ C$	$V_{OUT} = +2.7V$	(Notes 8, 9, 10)
I_{OZLT}	TRI-STATE Current Output Low	-1.0		mA	$-55^\circ C$ to $+125^\circ C$	$V_{OUT} = +0.5V$	(Notes 8, 9, 10)
I_{OS}	Output Short-Circuit CURRENT	-150	-60	mA	$-55^\circ C$ to $+125^\circ C$	$V_{OUT} = 0.0V$, $V_{TTL} = +5.5V$	(Notes 8, 9, 10)
I_{TTL}	V_{TTL} Supply Current		75 50 70	mA mA mA	$-55^\circ C$ to $+125^\circ C$	TTL Outputs Low TTL Output High TTL Output in TRI-STATE	(Notes 8, 9, 10)

Note 8: F100K 300 Series cold temperature testing is performed by temperature soaking (to guarantee junction temperature equals $-55^\circ C$), then testing immediately without allowing for the junction temperature to stabilize due to heat dissipation after power-up. This provides "cold start" specs which can be considered a worst case condition at cold temperatures.

Note 9: Screen tested 100% on each device at $-55^\circ C$, $+25^\circ C$, and $+125^\circ C$, Subgroups, 1, 2, 3, 7, and 8.

Note 10: Sample tested (Method 5005, Table I) on each manufactured lot at $-55^\circ C$, $+25^\circ C$, and $+125^\circ C$, Subgroups A1, 2, 3, 7, and 8.

Note 11: Guaranteed by applying specified input condition and testing V_{OH}/V_{OL} .

Military Version TTL-to-ECL AC Electrical Characteristics

$V_{EE} = -4.2V$ to $-5.7V$, $V_{TTL} = +4.5V$ to $+5.5V$, $V_{CC} = V_{CCA} = GND$

Symbol	Parameter	$T_C = -55^\circ C$		$T_C = 25^\circ C$		$T_C = +125^\circ C$		Units	Conditions	Notes
		Min	Max	Min	Max	Min	Max			
t_{PLH}	T_n to E_n (Transparent)	0.8	3.4	1.1	3.6	0.8	3.7	ns	Figures 1, 2	(Notes 12, 13, 14)
t_{PHL}								ns		
t_{PLH}	LE to E_n	1.2	3.8	1.4	3.7	1.1	3.8	ns	Figures 1, 2	
t_{PHL}								ns		
t_{PZH}	OE to E_n (Cutoff to HIGH)	0.8	3.6	1.5	4.0	2.0	5.2	ns	Figures 1, 2	(Notes 12, 13, 14)
t_{PHZ}	OE to E_n (HIGH to Cutoff)	1.5	4.6	1.6	4.2	1.6	4.3	ns	Figures 1, 2	
t_{PHZ}	DIR to E_n (HIGH to Cutoff)	1.6	4.7	1.6	4.3	1.7	4.3	ns	Figures 1, 2	
t_{set}	T_n to LE	2.5		2.0		2.5		ns	Figures 1, 2	(Note 15)
t_{hold}	T_n to LE	2.5		2.0		2.5		ns	Figures 1, 2	
$t_{pw(H)}$	Pulse Width LE	2.5		2.0		2.5		ns	Figures 1, 2	(Note 15)
t_{TLH}	Transition Time 20% to 80%, 80% to 20%	0.4	2.3	0.5	2.1	0.4	2.4	ns	Figures 1, 2	(Note 15)
t_{THL}										

**Military Version
ECL-to-TTL AC Electrical Characteristics**

$V_{EE} = -4.2V$ to $-5.7V$, $V_{TTL} = +4.5V$ to $+5.5V$, $V_{CC} = V_{CCA} = GND$, $C_L = 50$ pF

Symbol	Parameter	$T_C = -55^\circ C$		$T_C = 25^\circ C$		$T_C = +125^\circ C$		Units	Conditions	Notes
		Min	Max	Min	Max	Min	Max			
t_{PLH} t_{PHL}	E_n to T_n (Transparent)	2.1	6.0	2.0	5.6	2.2	6.3	ns	Figures 1, 2	(Notes 12, 13, 14)
t_{PLH} t_{PHL}	LE to T_n	3.1	7.0	3.1	6.5	3.3	7.5	ns	Figures 3, 4	
t_{PZH} t_{PZL}	OE to T_n (Enable Time)	3.2	8.0	3.7	8.0	4.0	9.2	ns	Figures 3, 4	(Notes 12, 13, 14)
t_{PHZ} t_{PLZ}	OE to T_n (Disable Time)	3.2	8.5	3.3	8.0	3.5	8.4	ns	Figures 3, 5	
t_{PHZ} t_{PLZ}	DIR to T_n (Disable Time)	2.6	7.0	2.6	7.0	2.9	8.0	ns	Figures 3, 6	
t_{set}	E_n to LE	2.5		2.0		2.5		ns	Figures 3, 4	(Note 15)
t_{hold}	E_n to LE	3.0		2.5		3.0		ns	Figures 3, 4	
$t_{pw(H)}$	Pulse Width LE	2.5		2.0		5.0		ns	Figures 3, 4	(Note 15)

Note 12: F100K 300 Series cold temperature testing is performed by temperature soaking (to guarantee junction temperature equals $-55^\circ C$), then testing immediately after power-up. This provides "cold start" specs which can be considered a worst case condition at cold temperatures.

Note 13: Screen tested 100% on each device at $+25^\circ C$, temperature only, Subgroup A9.

Note 14: Sample tested (Method 5005, Table I) on each mfg. lot at $+25^\circ C$, Subgroup A9, and at $+125^\circ C$ and $-55^\circ C$ temperatures, Subgroups A10 and A11.

Note 15: Not tested at $+25^\circ C$, $+125^\circ C$ and $-55^\circ C$ temperature (design characterization data).

Test Circuitry (TTL-to-ECL)

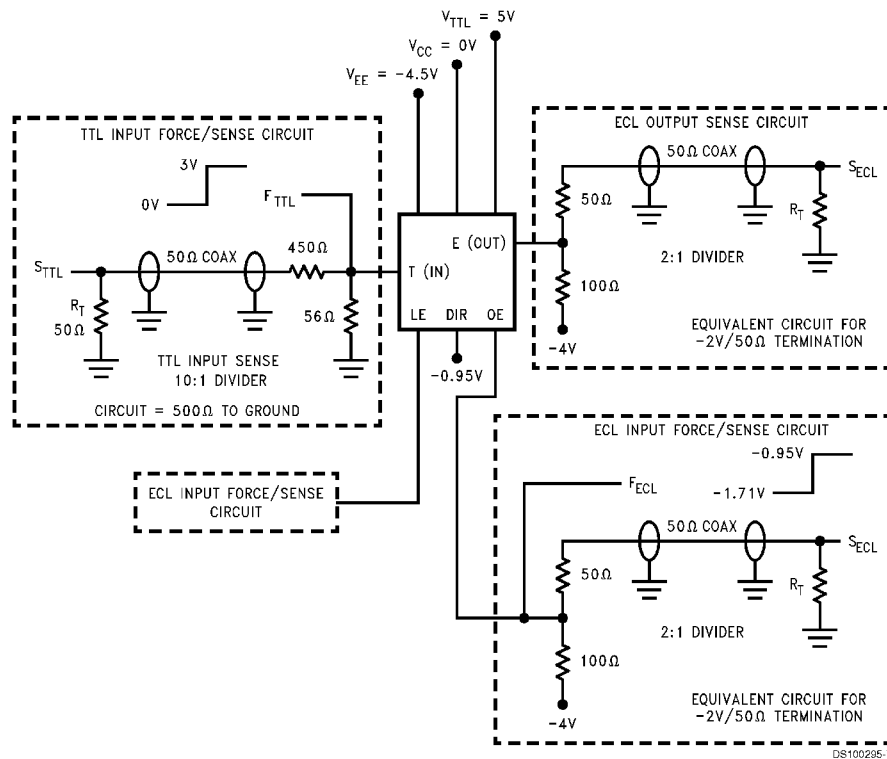

Note 16: $R_t = 50\Omega$ termination. When an input or output is being monitored by a scope, R_t is supplied by the scope's 50Ω resistance. When an input or output is not being monitored, an external 50Ω resistance must be applied to serve as R_t .

Note 17: TTL and ECL force signals are brought to the DUT via 50Ω coax lines.

Note 18: V_{TTL} is decoupled to ground with $0.1\ \mu\text{F}$ to ground, V_{EE} is decoupled to ground with $0.01\ \mu\text{F}$ and V_{CC} is connected to ground.

Note 19: For ECL input pins, the equivalent force/sense circuitry is optional.

FIGURE 1. TTL-to-ECL AC Test Circuit

Switching Waveforms (TTL-to-ECL)

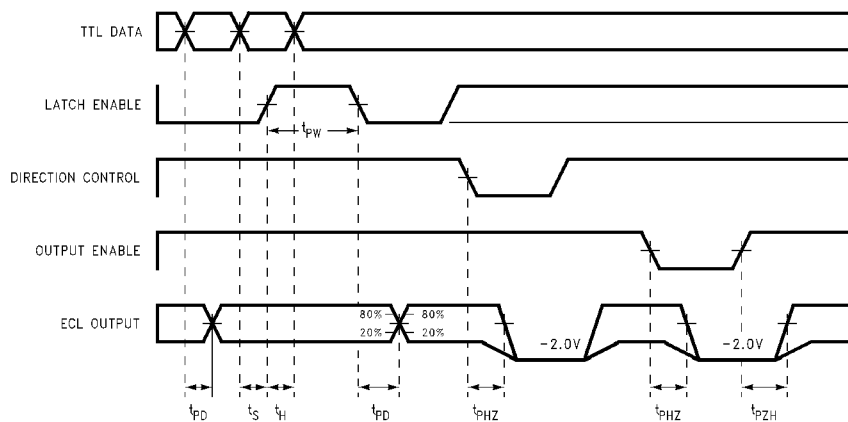
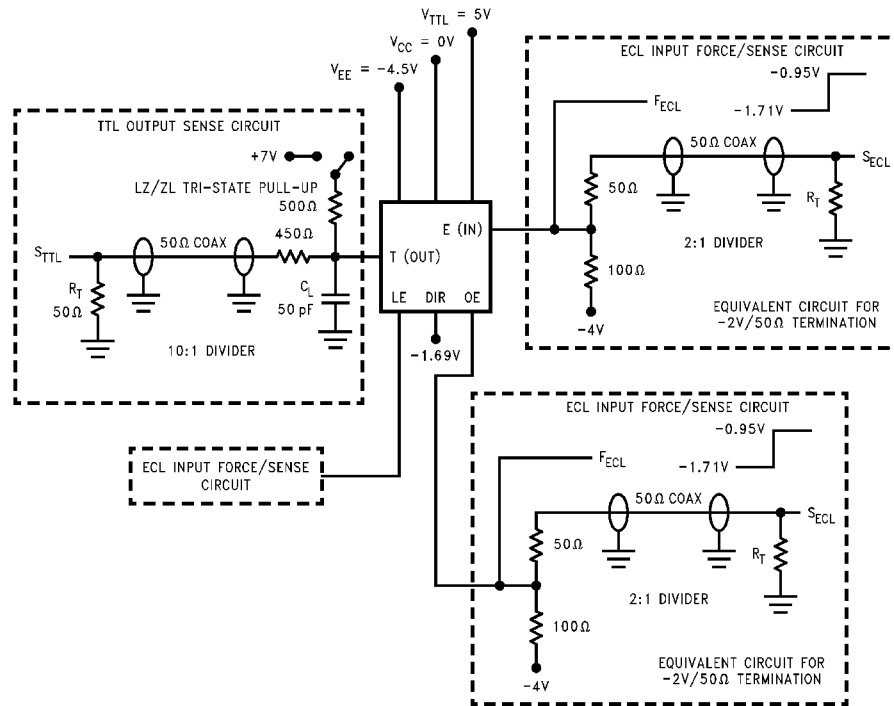

FIGURE 2. TTL to ECL Transition—Propagation Delay and Transition Times

Test Circuitry (ECL-to-TTL)



DS100295-10

Note 20: $R_T = 50\Omega$ termination. When an input or output is being monitored by a scope, R_T is supplied by the scope's 50Ω resistance. When an input or output is not being monitored, an external 50Ω resistance must be applied to serve as R_T .

Note 21: The TTL TRI-STATE pull up switch is connected to +7V only for LZ and LZ tests.

Note 22: TTL and ECL force signals are brought to the DUT via 50Ω coax lines.

Note 23: V_{TTL} is decoupled to ground with $0.1\ \mu\text{F}$, V_{EE} is decoupled to ground with $0.01\ \mu\text{F}$ and V_{CC} is connected to ground.

FIGURE 3. ECL-to-TTL AC Test Circuit

Switching Waveforms (ECL-to-TTL)

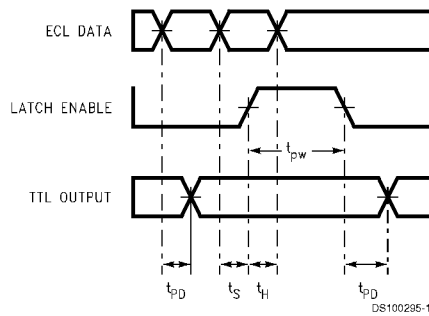

DS100295-11

Note 24: DIR is LOW, and OE is HIGH

FIGURE 4. ECL-to-TTL Transition—Propagation Delay and Transition Times

Switching Waveforms (ECL-to-TTL) (Continued)

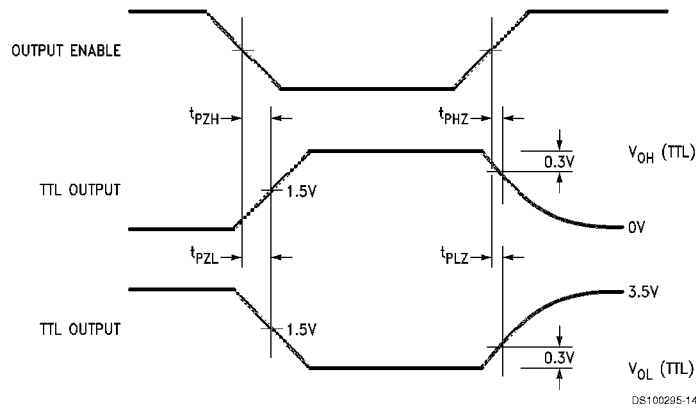

Note 25: DIR is LOW, LE is HIGH

FIGURE 5. ECL-to-TTL Transition, OE to TTL Output, Enable and Disable Times

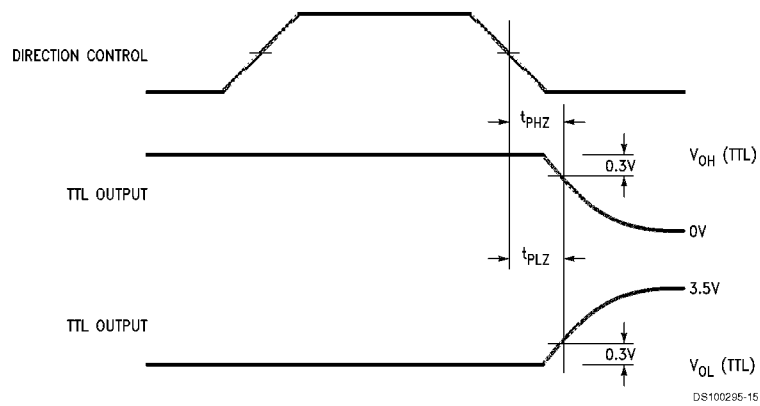

Note 26: OE is HIGH, LE is HIGH

FIGURE 6. ECL-to-TTL Transition, DIR to TTL Output, Disable Time

Applications

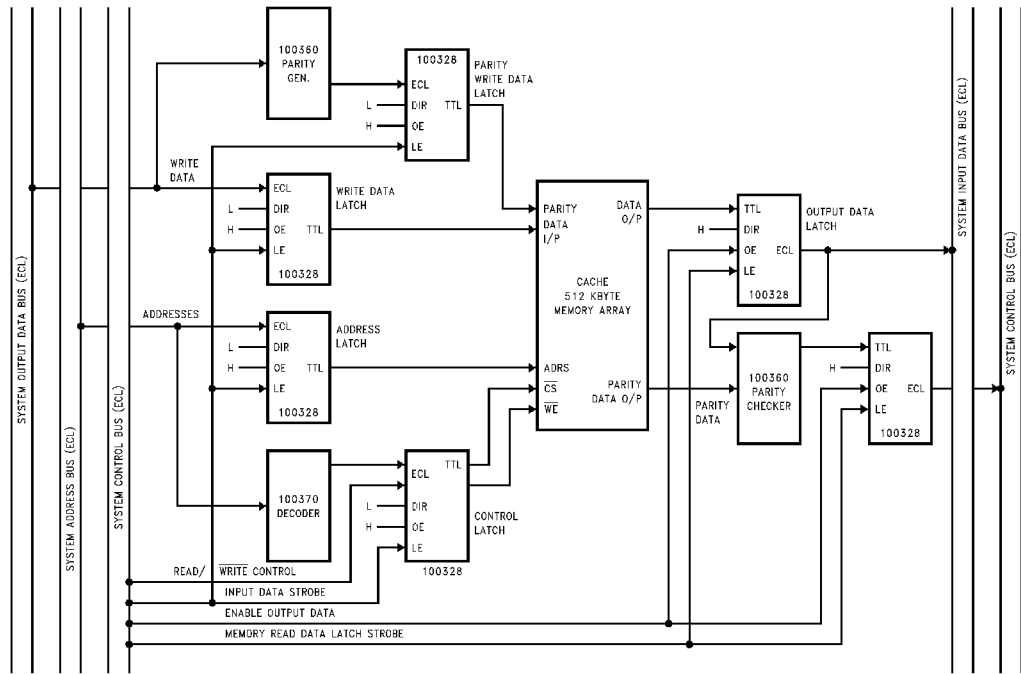

DS100295-12

FIGURE 7. Applications Diagram—MOS/TTL SRAM Interface Using 100328 ECL–TTL Latched Translator

Ordering Information

The device number is used to form part of a simplified purchasing code where A package type and temperature range are defined as follows:

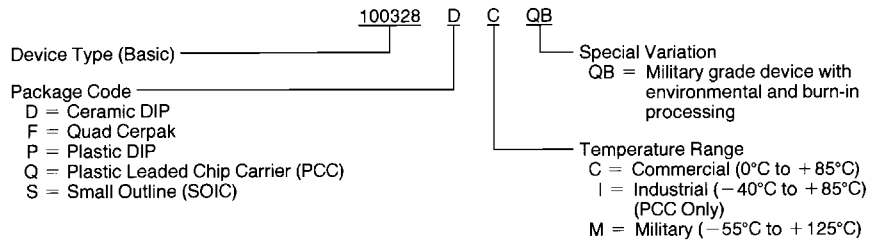

DS100295-16

Physical Dimensions inches (millimeters) unless otherwise noted

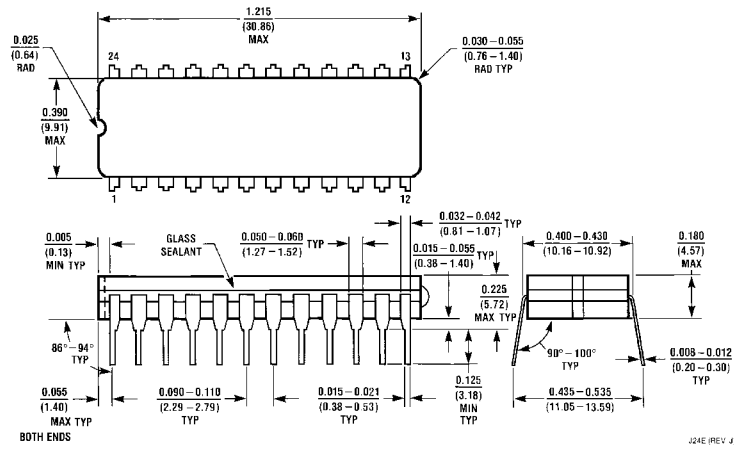

24-Lead Ceramic Dual-In-Line Package (0.400" Wide) (D)
NS Package Number J24E

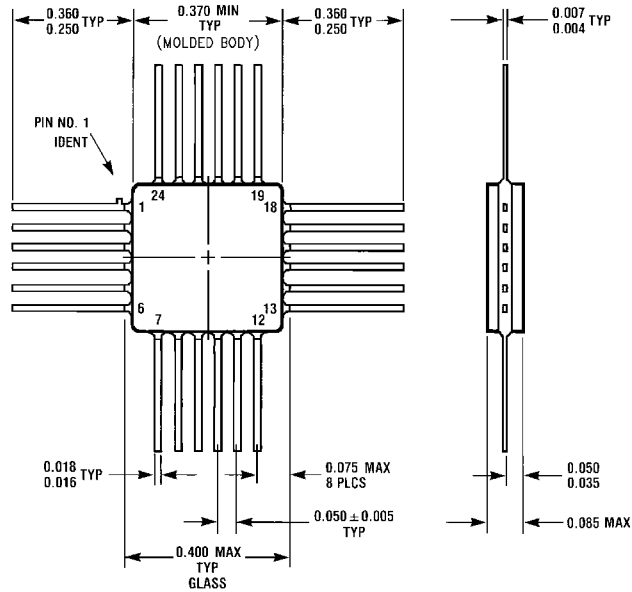

24-Lead Quad Cerpak (F)
NS Package Number W24B

LIFE SUPPORT POLICY

NATIONAL'S PRODUCTS ARE NOT AUTHORIZED FOR USE AS CRITICAL COMPONENTS IN LIFE SUPPORT DEVICES OR SYSTEMS WITHOUT THE EXPRESS WRITTEN APPROVAL OF THE PRESIDENT OF NATIONAL SEMICONDUCTOR CORPORATION. As used herein:

1. Life support devices or systems are devices or systems which, (a) are intended for surgical implant into the body, or (b) support or sustain life, and whose failure to perform when properly used in accordance with instructions for use provided in the labeling, can be reasonably expected to result in a significant injury to the user.
2. A critical component in any component of a life support device or system whose failure to perform can be reasonably expected to cause the failure of the life support device or system, or to affect its safety or effectiveness.



National Semiconductor Corporation
Americas
Tel: 1-800-272-9959
Fax: 1-800-737-7018
Email: support@nsc.com

www.national.com

National Semiconductor Europe
Fax: +49 (0) 1 80-530 85 86
Email: europe.support@nsc.com
Deutsch Tel: +49 (0) 1 80-530 85 85
English Tel: +49 (0) 1 80-532 78 32
Français Tel: +49 (0) 1 80-532 93 58
Italiano Tel: +49 (0) 1 80-534 16 80

National Semiconductor Asia Pacific Customer Response Group
Tel: 65-2544466
Fax: 65-2504466
Email: sea.support@nsc.com

National Semiconductor Japan Ltd.
Tel: 81-3-5620-6175
Fax: 81-3-5620-6179