

**30 mW, 685 nm VISIBLE LASER DIODE
FOR HIGH DENSITY MAGNETIC OPTICAL DISK APPLICATIONS**

DESCRIPTION

NDL3230 is an AlGaInP visible laser diode and especially developed for high density magnetic optical disk. Higher density than 780 nmLD.

FEATURES

- Optical output power $P_o = 30$ mW (TYP.)
- High reliability
- Peak Emission Wavelength $\lambda_p = 685$ nm (TYP.)
- Internal PIN detector
- Fundamental transverse mode

QUALITY GRADE

Standard

Please refer to "Quality grade on NEC Semiconductor Devices" (Document number IEI-1209) published by NEC Corporation to know the specification of quality grade on the devices and its recommended applications.

ABSOLUTE MAXIMUM RATINGS ($T_c = 25$ °C)

Optical output power	P_o	30	mW
Reverse Voltage	V_R	2.0	V
Operating case temperature	T_c	-10 to +60	°C
Storage temperature	T_{stg}	-40 to +85	°C
Monitor PD			
Reverse Voltage	V_R	30	V
Forward Current	I_f	20	mA

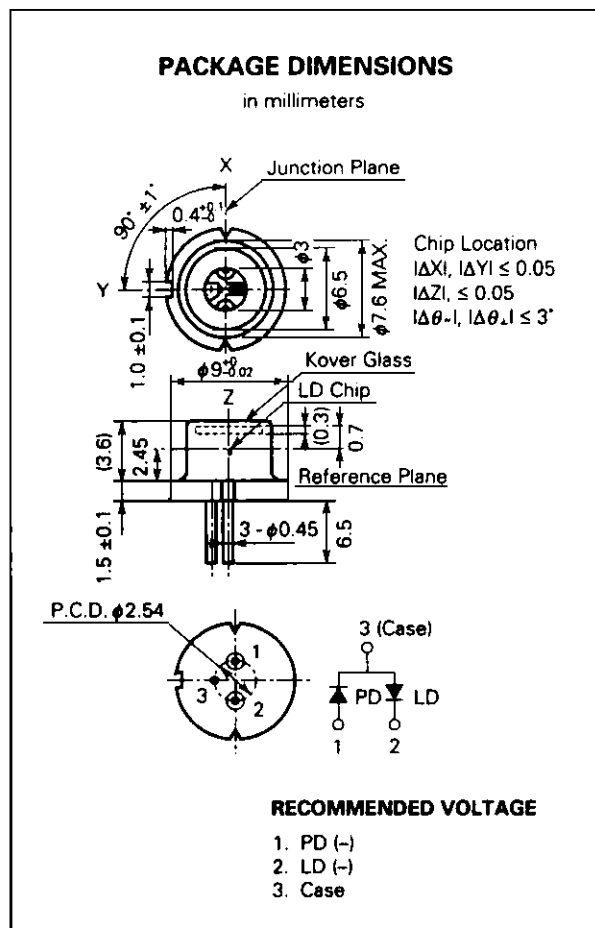

RECOMMENDED OPERATING CONDITIONS ($T_c = 25$ °C)

CHARACTERISTIC	SYMBOL	MIN.	TYP.	MAX.	UNIT
Optical output power	P_o			30	mW

The information in this document is subject to change without notice.

ELECTRO-OPTICAL CHARACTERISTICS (T_c = 25 °C)

CHARACTERISTIC	SYMBOL	MIN.	TYP.	MAX.	UNIT	TEST CONDITIONS
Operating Voltage	V _{op}		2.4	2.7	V	P _o = 30 mW
Threshold Current	I _{th}		50	60	mA	CW
Operating Current	I _{op}		100	120	mA	P _o = 30 mW
Monitor Current	I _m	0.05	0.1	0.3	mA	V _n = 5 V, P _o = 30 mW
Peak Emission Wavelength	λ _p	670	685	695	nm	P _o = 30 mW
Vertical Beam Angle	θ _L	17	20	23	deg	P _o = 30 mW, FAHM*
Lateral Beam Angle	θ _H	7	9	12	deg	P _o = 30 mW, FAHM*

* FAHM: Full Angle at Half Maximum

PACKAGE DIMENSIONS

in millimeters

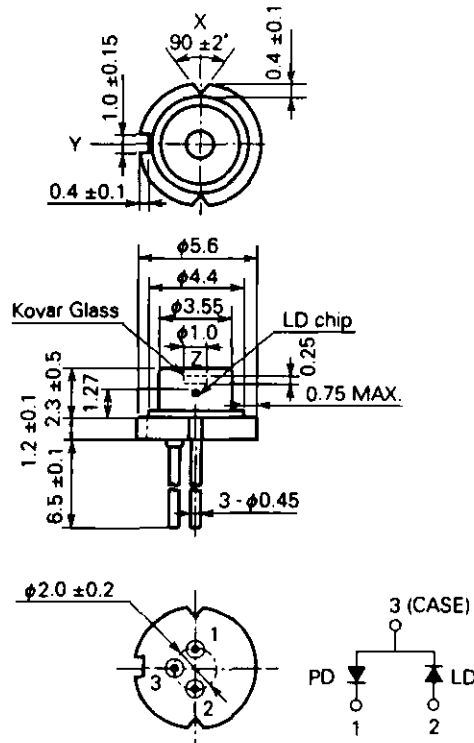

LEAD CONNECTION

1. PD (+)
2. LD (+)
3. CASE

NDL3230SU

[MEMO]

No part of this document may be copied or reproduced in any form or by any means without the prior written consent of NEC Corporation. NEC Corporation assumes no responsibility for any errors which may appear in this document.

NEC Corporation does not assume any liability for infringement of patents, copyrights or other intellectual property rights of third parties by or arising from use of a device described herein or any other liability arising from use of such device. No license, either express, implied or otherwise, is granted under any patents, copyrights or other intellectual property rights of NEC Corporation or others.

The devices listed in this document are not suitable for use in aerospace equipment, submarine cables, nuclear reactor control systems and life support systems. If customers intend to use NEC devices for above applications or they intend to use "Standard" quality grade NEC devices for applications not intended by NEC, please contact our sales people in advance.

Application examples recommended by NEC Corporation

Standard: Computer, Office equipment, Communication equipment, Test and Measurement equipment, Machine tools, Industrial robots, Audio and Visual equipment, Other consumer products, etc.

Special: Automotive and Transportation equipment, Traffic control systems, Antidisaster systems, Anticrime systems, etc.

M4 92.6