

Helping Customers Innovate, Improve & Grow

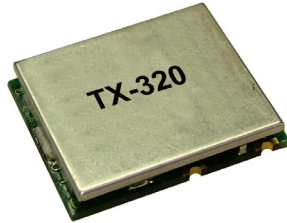

TX-320

### Description

The TX-320 series surface mount TCXO can be mounted using the standard convection reflow process. Current drain to less than 5 mA is available upon request. Aging <5 ppm for ten years.

### Features

- Low Profile
- TTL / HCMOS Output
- Frequency Range: 1 MHz to 77.76 MHz
- Previous Model: TC-350, C2490

### Applications

- SMC Clock
- SONET/SDH Network Timing Sources
- Wireless Communications
- Satellite Communications

### Performance Specifications

Parameter	Min	Typ	Max	Units	Condition
<b>Frequency Stabilities<sup>1</sup></b>					
vs. operating temperature range (referenced to +25°C)	-2.5		+2.5	ppm	-55... +85°C
	-1.5		+1.5	ppm	-55... +85°C
	-2.0		+2.0	ppm	-40... +85°C
	-1.0		+1.0	ppm	-40... +85°C
	-1.5		+1.5	ppm	-20... +70°C
	-0.75		+0.75	ppm	-20... +70°C
	-1.0		+1.0	ppm	0... +70°C
	-0.5		+0.5	ppm	0... +70°C
	-1.0		+1.0	ppm	0... +50°C
	-0.5		+0.5	ppm	0... +50°C
vs. supply voltage change			+0.1	ppm	V <sub>s</sub> ± 5%
vs. aging / 10 years			+5	ppm	@ +70°C
<b>Supply Voltage (V<sub>s</sub>)</b>					
Supply voltage	3.135	3.3	3.465	VDC	
Supply voltage	4.75	5.0	5.25	VDC	

## Performance Specifications

Parameter	Min	Typ	Max	Units	Condition
<b>RF Output</b>					
Signal	HCMOS/ACMOS				
Load		10		pF	
Signal Level (Vol)			+0.5	V	
Signal Level (Voh)	0.8			V	
Rise/Fall Time			5	ns	
Duty cycle	40		60	%	@ (Voh-Vol)/2
Signal	TTL				
Load					10 TTL
Signal Level (Vol)			+0.5	VDC	with Vs=12.0V or 5.0V and 15pF load
Signal Level (Voh)	+2.4			VDC	with Vs=12.0V or 5.0V and 15pF load
Rise/Fall Time			10	ns	
Duty cycle	40		60	%	@ (Voh-Vol)/2
<b>Frequency Tuning (EFC)</b>					
Tuning Range	±5.0			ppm	via external voltage, 0 to +Vdd

## Outline Drawing / Enclosure

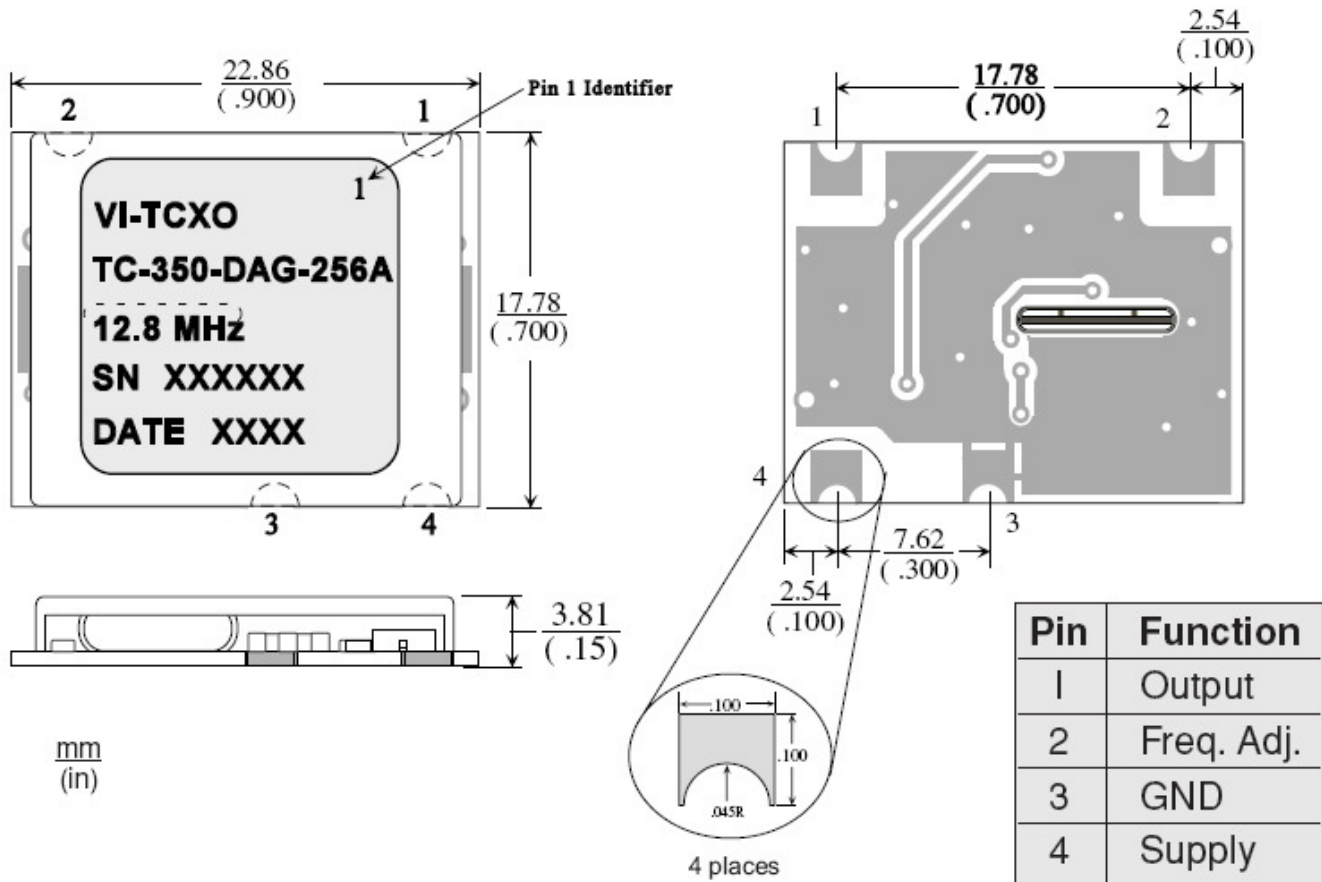

## Recommended Pad Layout

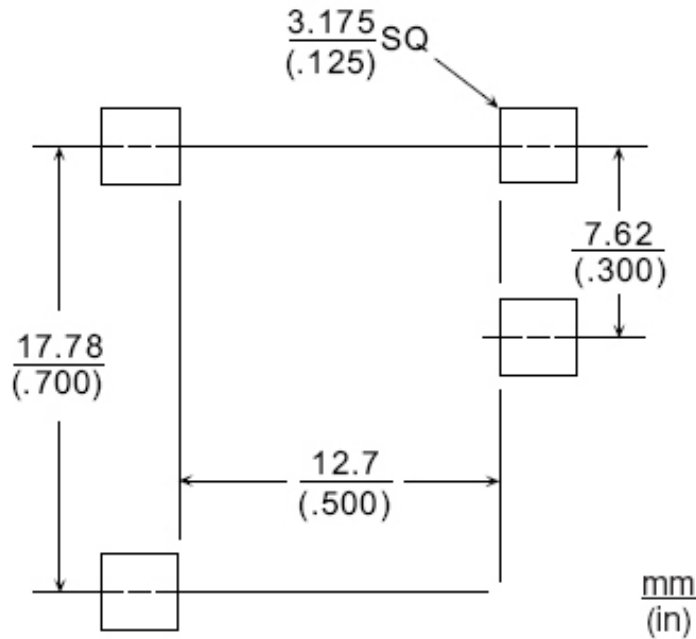

## Recommended Reflow Profile

### Convection Reflow Profile

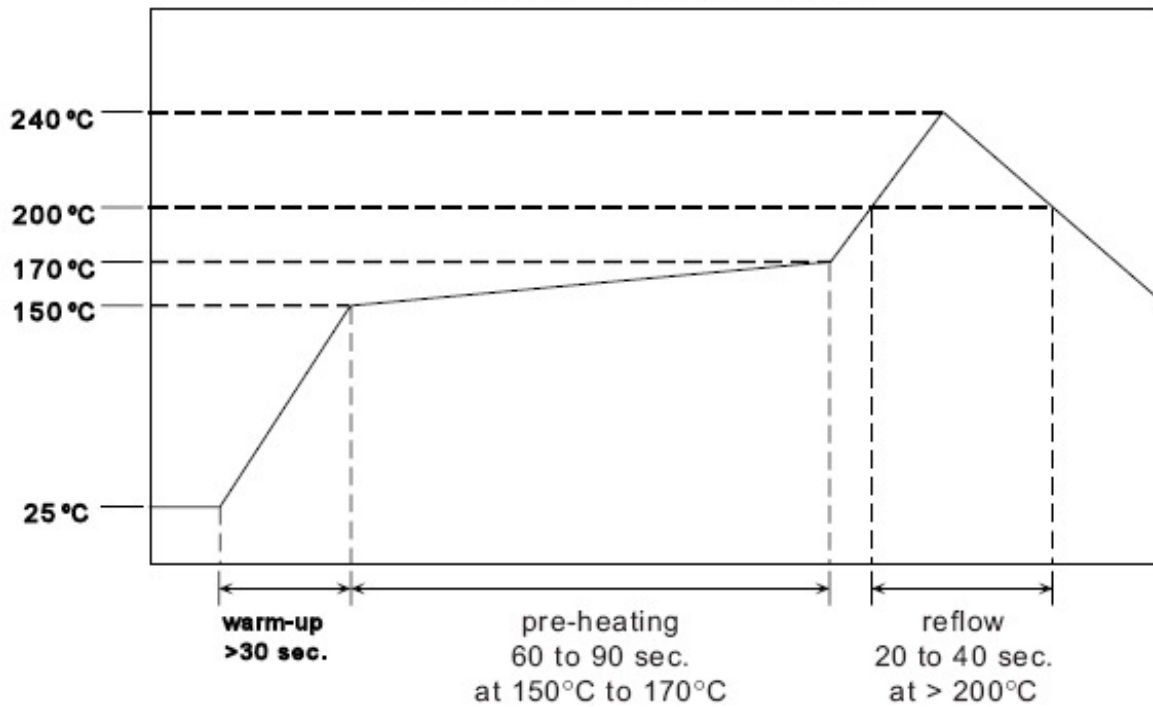

Note: TCXO's are precision subsystems with tolerances measured to 0.01 ppm. Non-Hermetically sealed TCXO's should not be subjected to a wash process that will immerse the TCXO in solvents. NO CLEAN is the recommended procedure. The TX-320 series of TCXO's has been designed for pick and place reflow soldering. The suggested reflow profile is shown above. The TCXO may be reflowed one time in the non-inverted state. Typical frequency shift as a result of reflow is <1.0 ppm per reflow. VI recommends waiting at least two hours after reflow below measuring the unit.

## Output Loads

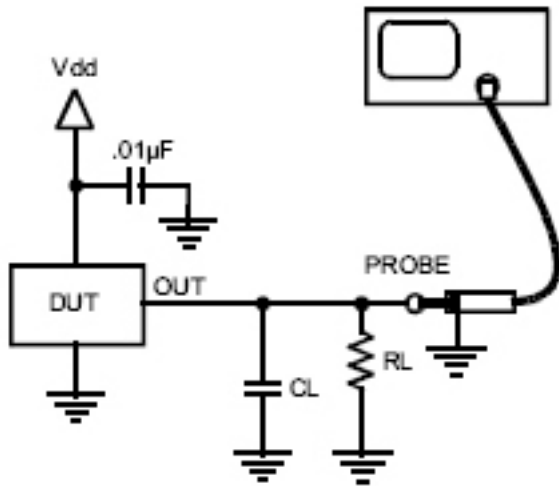

(A) HCMOS / ACMOS

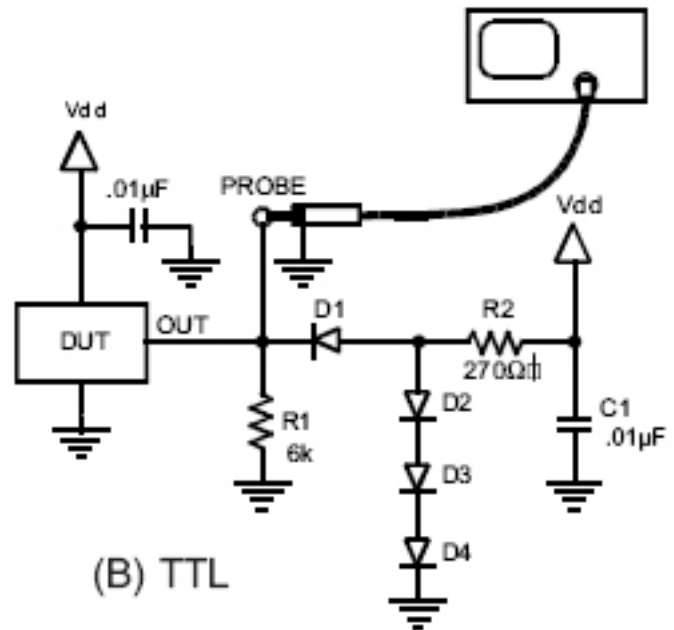

(B) TTL

## Standard Shipping Method

The Standard ship method for volume production of the TX-320 series is in a matrix tray. These trays are 100% recyclable. The trays also offer the added feature that they can be continuously feed into a pick-n-place machine eliminating the down time required with tape-n-reel.

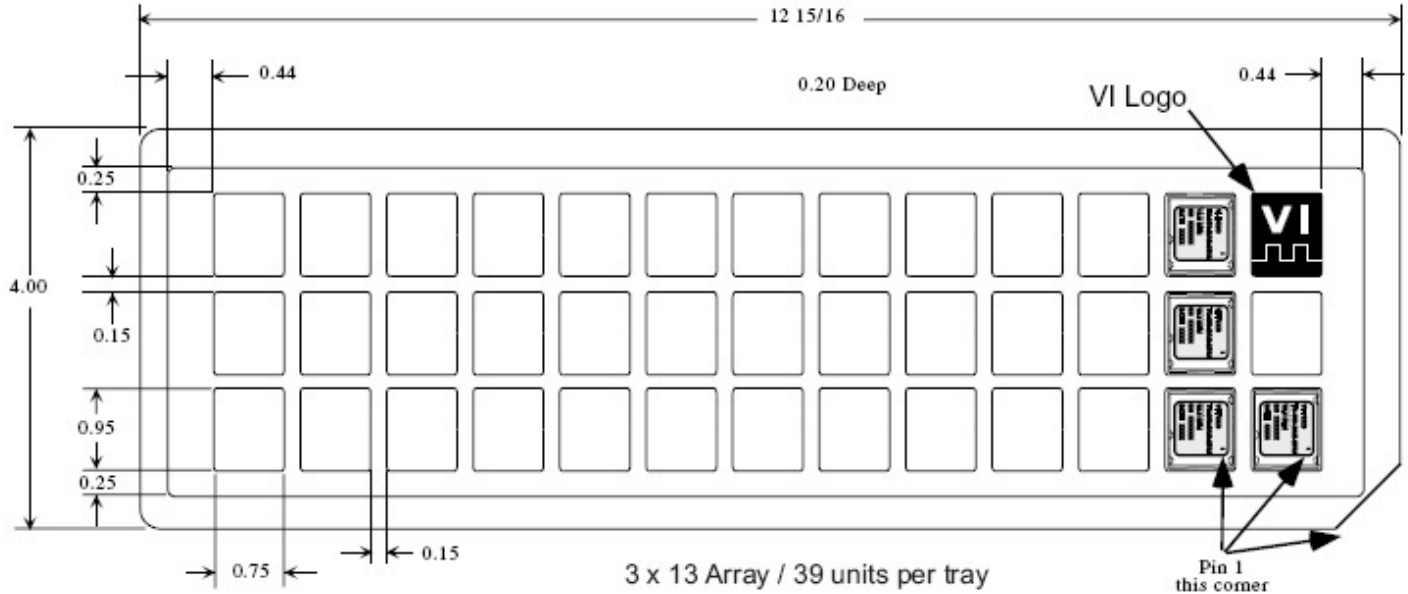

## Handling Precautions

Although protection circuitry has been designed into this device, proper precautions should be taken to avoid exposure to electrostatic discharge (ESD) during handling and mounting. VI employs a human-body model (HBM) and a charged-device model (CDM) for ESD-susceptibility testing and protection design evaluation. ESD voltage thresholds are depending on the circuit parameters used to define the mode.

Although no industry-wide standard has been adopted for the CDM, a standard HBM (resistance =1500 ohms, capacitance - 1000 pf) is widely used and therefore can be used for comparison purposes. The HBM ESD threshold presented here was obtained by using these circuit parameters.

ESD Threshold Voltage		
Model	Threshold	Unit
Human-Body (HBM)	500	V min
Charged-Device	500	V min

## Ordering Information

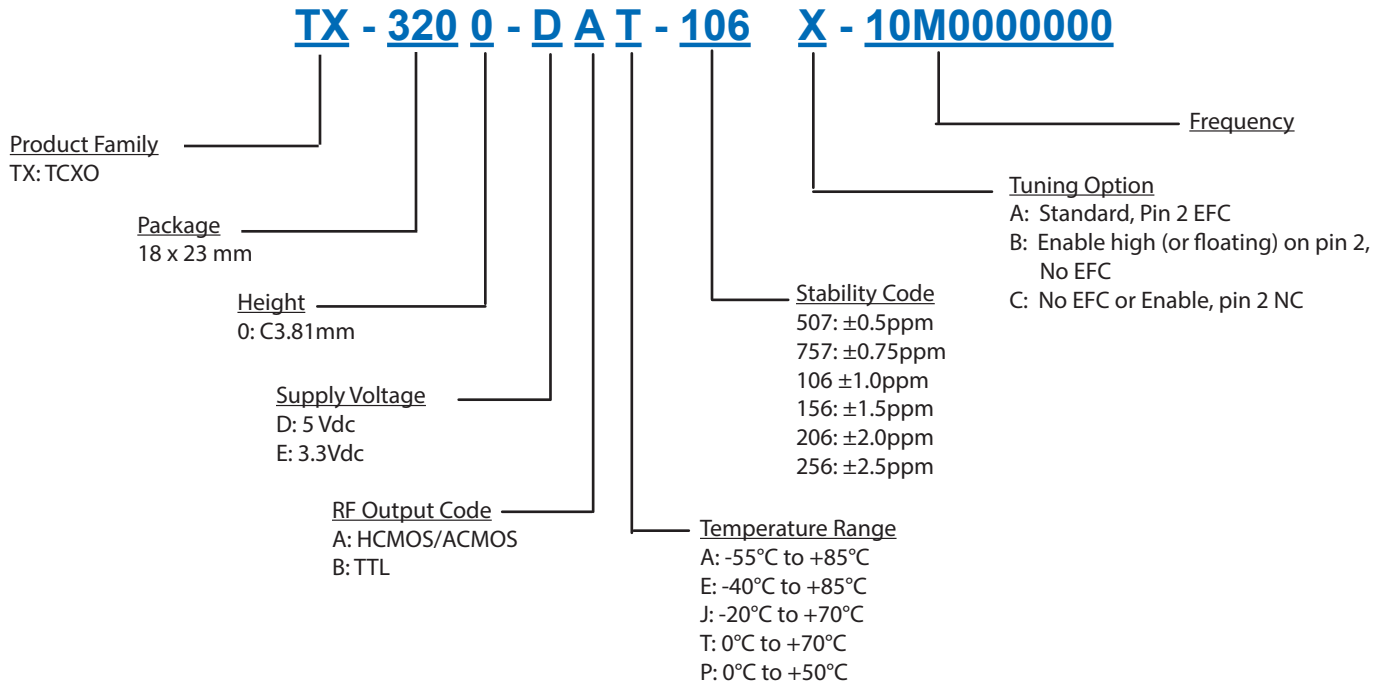

**Notes:**

1. Contact factory for improved stabilities or additional product options. Not all options and codes are available at all frequencies.
2. Unless other stated all values are valid after warm-up time and refer to typical conditions for supply voltage, frequency control voltage, load, temperature (25°C).
3. Phase noise degrades with increasing output frequency.
4. Subject to technical modification.
5. Contact factory for availability.

## For Additional Information, Please Contact

**USA:**

Vectron International  
267 Lowell Road, Suite 102  
Hudson, NH 03051  
Tel: 1.888.328.7661  
Fax: 1.888.329.8328

**Europe:**

Vectron International  
Landstrasse, D-74924  
Neckarbischofsheim, Germany  
Tel: +49 (0) 3328.4784.17  
Fax: +49 (0) 3328.4784.30

**Asia:**

Vectron International  
68 Yin Cheng Road(C), 22nd Floor  
One LuJiaZui  
Pudong, Shanghai 200120, China  
Tel: +86 21 6194 6886  
Fax: +86 21 6194 6699

**Disclaimer**

Vectron International reserves the right to make changes to the product(s) and or information contained herein without notice. No liability is assumed as a result of their use or application. No rights under any patent accompany the sale of any such product(s) or information.

Rev: 2-18-2014 jar