

Fast Switching MOSFETs With Integrated Driver

PRODUCT SUMMARY	
Input Voltage Range	3.3 to 20 V
Output Voltage Range	0.5 to 6 V
Operating Frequency	100 kHz to 1 MHz
Continuous Output Current	Up to 25 A
Peak Efficiency	97.5
Optimized Duty Cycle Ratio	40 %

PowerPAK® MLF 9 x 9

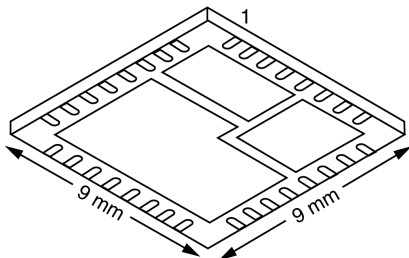

Bottom View

Ordering Information: SiC730CD9-T1-E3 (Lead (Pb)-free)

* see page 2 for peak temperature

FEATURES

- Low-side MOSFET control pin for pre-bias start-up
- Undervoltage Lockout for safe operation
- Internal bootstrap diode reduces component count
- Break-Before-Make operation
- Turn-on/Turn-off Capability
- Compatible with any single or multi-phase PWM controller
- Low profile, thermally enhanced PowerPAK® MLF 9 x 9 Package



RoHS
COMPLIANT

APPLICATIONS

- DC-to-DC Point-of-Load Converters
 - 3.3 V, 5 V, or 12 V Intermediate BUS
 - Examples
 - 12 V_{IN} / 3.3 - 5 V_{OUT}
 - 5 V_{IN} / 1.5 - 3.3 V_{OUT}
- Servers and Computers
- Single and Multi-Phase Conversion

DESCRIPTION

The SiC730CD9 is an integrated solution which contains two PWM-optimized MOSFETs (high side and low side MOSFETs) and a driver IC. Integrating the driver allows better optimization of Power MOSFETs. This minimizes the losses and provides better performance at higher frequency. The SiC730CD9 is packed in Vishay Siliconix's high performance PowerPAK MLF 9 x 9 package. Compact co-packing of components helps to reduce stray inductance, and hence increases efficiency.

The SiC730CD9 is packed in Vishay Siliconix's high performance PowerPAK MLF 9 x 9 package. Compact co-packing of components helps to reduce stray inductance, and hence increases efficiency.

FUNCTIONAL BLOCK DIAGRAM

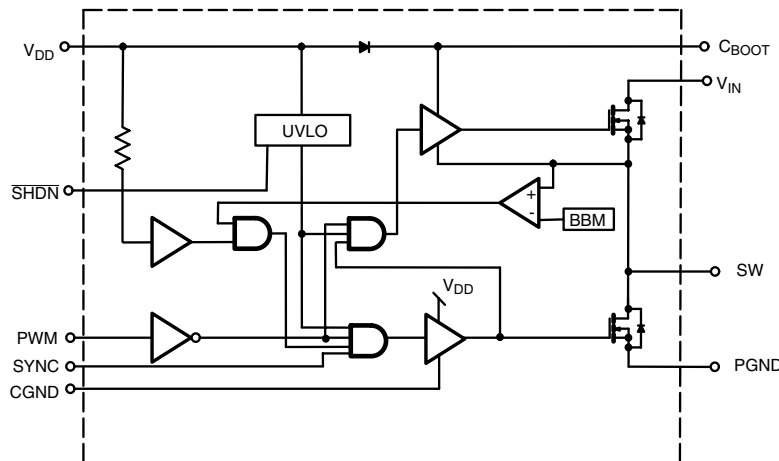

Figure 1.

ABSOLUTE MAXIMUM RATINGS $T_A = 25\text{ }^\circ\text{C}$, unless otherwise noted			
Parameter	Symbol	Steady State	Unit
Logic Supply	V_{DD}	7	V
Logic Inputs	V_{PWM}	7.3	
Common Switch Node	V_{SW}	30	
Drain Voltage	V_{IN}	30	
Bootstrap Voltage	V_{BOOT}	SW + 7	
Maximum Power Dissipation (Measured at $25\text{ }^\circ\text{C}$)	P_D	6	W
Operating Junction and Storage Temperature Range	T_j, T_{stg}	- 65 to 125	$^\circ\text{C}$
Soldering Recommendations (Peak Temperature) ^{a, b}		245	

Stresses beyond those listed under "Absolute Maximum Ratings" may cause permanent damage to the device. These are stress ratings only, and functional operation of the device at these or any other conditions beyond those indicated in the operational sections of the specifications is not implied. Exposure to absolute maximum rating/conditions for extended periods may affect device reliability.

RECOMMENDED OPERATING CONDITIONS			
Parameter	Symbol	Steady State	Unit
Drain Voltage	V_{IN}	3.3 to 20	V
Logic Supply	V_{DD}	4.5 to 5.5	
Input Logic PWM Voltage	V_{PWM}	5	
Bootstrap Capacitor	C_{BOOT}	100 n to 1μ	F

THERMAL RESISTANCE RATINGS					
Parameter ^c		Symbol	Typical	Maximum	Unit
Maximum Junction-to-Case	Steady State	R_{thJC}	3.5	4.5	$^\circ\text{C/W}$
Maximum Junction-to-Ambient (PCB = Copper 25 mm x 25 mm)		R_{thJA}	60	75	

Notes:

- See Reliability Manual for profile. The PowerPAK MLF 9 x 9 is a leadless package. The end of the lead terminal is exposed copper (not plated) as a result of the singulation process in manufacturing. A solder fillet at the exposed copper tip cannot be guaranteed and is not required to ensure adequate bottom side soldering interconnection.
- Rework Conditions: manual soldering with a soldering iron is not recommended for leadless components.
- Junction-to-case thermal impedance represents the effective thermal impedance of all heat carrying leads in parallel and is intended for use in conjunction with the thermal impedance of the PC board pads to ambient ($R_{thJA} = R_{thJC} + R_{thPCB-A}$). It can also be used to estimate chip temperature if power dissipation and the lead temperature of heat carrying (drain) lead is known.



SPECIFICATIONS							
Parameter	Symbol	Test Condition Unless Specified $T_A = 25\text{ }^\circ\text{C}$ $4.5\text{ V} < V_{DD} < 5.5\text{ V}, 4.5\text{ V} < V_{IN} < 20\text{ V}$	Limits			Unit	
			Min	Typ ^a	Max		
Controller							
Logic Voltage	V_{DD}		4.5		5.5	V	
Logic Current (Static)	$I_{DD(EN)}$	$V_{DD} = 4.5\text{ V}, \text{SYNC} = \text{H}, \text{PWM} = \text{H}, \overline{\text{SHDN}} = \text{H}$		1200		μA	
	$I_{DD(DIS)}$	$V_{DD} = 4.5\text{ V}, \text{SYNC} = \text{H}, \text{PWM} = \text{H}, \overline{\text{SHDN}} = \text{L}$		120			
Logic Current (Dynamic)	$I_{DD1(DYN)}$	$V_{DD} = 5\text{ V}, f_{\text{PWM}} = 250\text{ kHz}^c$		28		mA	
	$I_{DD2(DYN)}$	$V_{DD} = 5\text{ V}, f_{\text{PWM}} = 700\text{ kHz}^c$		56			
Logic Input							
Logic Input (VPWM)	High	$V_{\text{PWH}}H$	$V_{DD} = 5\text{ V}, \text{SYNC} = \text{H}, \overline{\text{SHDN}} = \text{H}$	2.5		V	
	Low	$V_{\text{PWL}}L$			1.35		
Logic Input Voltage (V_{SYNC})	V_{SYNC}	$V_{DD} = 5\text{ V}, \text{PMW} = \text{H}, \overline{\text{SHDN}} = \text{H}$		2.0			
Logic Input Voltage (V_{SHDN})	V_{SHDN}	$V_{DD} = 5\text{ V}, \text{PMW} = \text{H}, \text{SYNC} = \text{H}$		2.0			
Input Voltage Hysteresis (PWM)	V_{HYS}			400		mV	
Logic Input Current	I_{SHDN}	$V_{DD} = 5.5\text{ V}, \overline{\text{SHDN}} = 0\text{ V}$		116		μA	
	I_{PWM}	$V_{DD} = 5.5\text{ V}, \text{PMW} = 5.5\text{ V}$		114			
Protection							
Break-Before-Make Reference	V_{BBM}	$V_{DD} = 5.5\text{ V}$		2.4		V	
Under-Voltage Lockout	V_{UVLO}	$V_{DD} = 5\text{ V}, \text{SYNC} = \text{H}, \overline{\text{SHDN}} = \text{H}$	3.5	4.1	4.25		
Under-Voltage Lockout Hysteresis	V_{H}			0.4			
MOSFETs							
Drain-Source Voltage	V_{DS}	$I_{\text{D}} = 250\text{ }\mu\text{A}$		30	32	V	
Drain-Source On-State Resistance ^a	$r_{\text{DS(on)1}}$	$V_{DD} = 5\text{ V}, I_{\text{D}} = 10\text{ A}$ $T_A = 25\text{ }^\circ\text{C}$	High-Side		8	10.4	$\text{m}\Omega$
	$r_{\text{DS(on)2}}$		Low-Side		3.6	4.32	
Diode Forward Voltage ^a	V_{SD1}	$I_{\text{S}} = 2\text{ A}, V_{\text{GS}} = 0\text{ V}$	High-Side		0.7	1.1	V
	V_{SD2}		Low-Side		0.67	1.1	
Dynamic^{b, c}							
Turn On Delay Time	$t_{\text{d(on)}}$	50 % - 50 % ^c			57	ns	
Turn Off Delay Time	$t_{\text{d(off)}}$				34		

Notes:

- a) Pulse test; pulse width $\leq 300\text{ ms}$, duty cycle $\leq 2\%$.
- b) Typical values are for DESIGN AID ONLY, not guaranteed nor subject to production testing.
- c) Using application board SiDB766706.

TIMING DIAGRAM

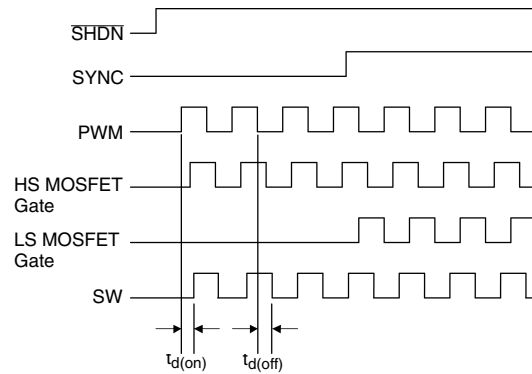

Figure 2.

APPLICATION INFORMATION^a (25 °C, unless noted, LFM = 0)

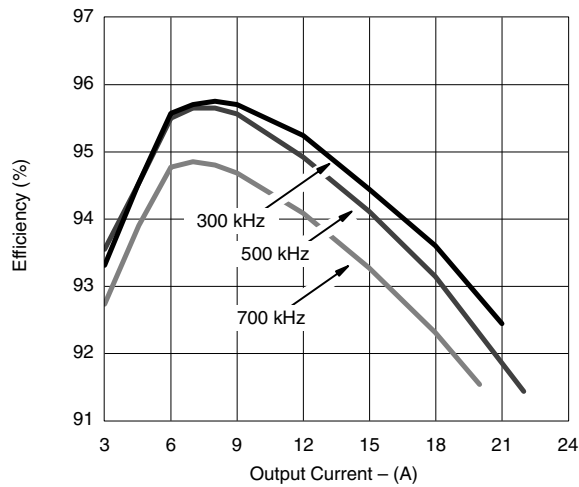

Figure 3. Total Efficiency 12 V_{IN}/3.3 V_{OUT}

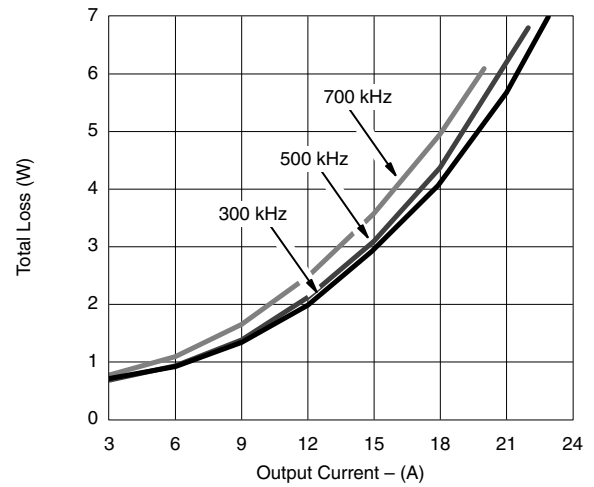

Figure 4. Total Loss 12 V_{IN}/3.3 V_{OUT}

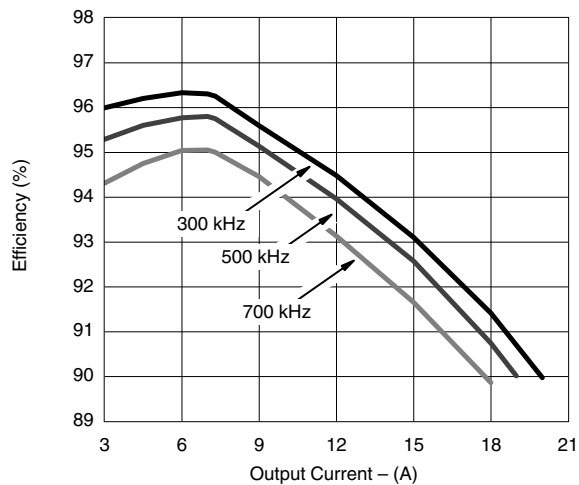

Figure 5. Total Efficiency 5 V_{IN}/2.5 V_{OUT}

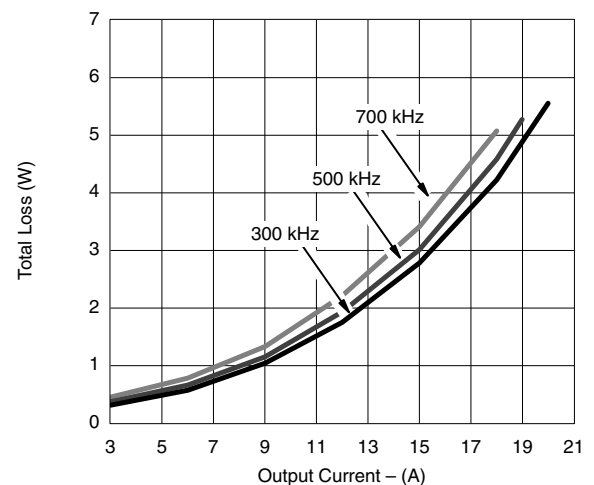

Figure 6. Total Loss 5 V_{IN}/2.5 V_{OUT}

Notes:

a) Experimental results using an evaluation board with a specific set of operating conditions.

PIN CONFIGURATION

PowerPAK MLF 9 mm × 9 mm (Bottom View)

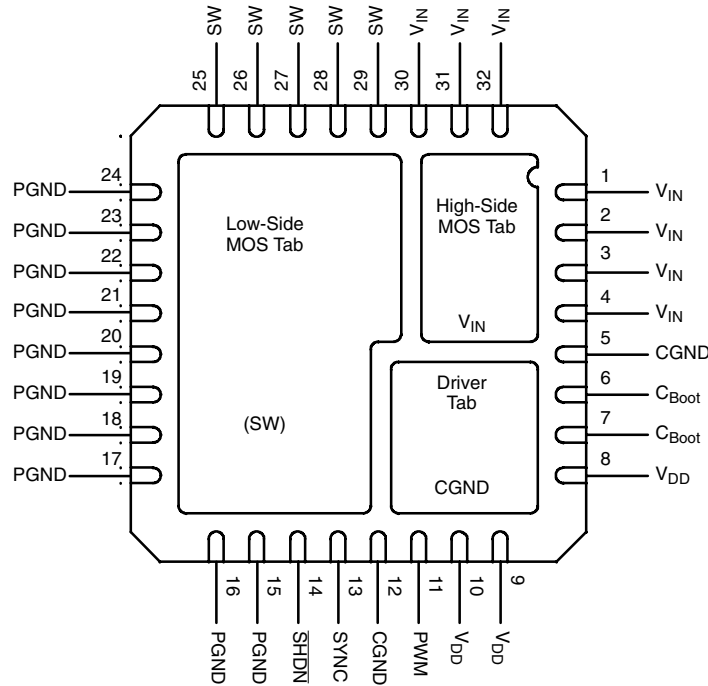

TRUTH TABLE				
SHDN	SYNC	PWM	HS MOSFET	LS MOSFET
L	X	X	OFF	OFF
H	L	L	OFF	OFF
H	L	H	ON	OFF
H	H	L	OFF	ON
H	H	H	ON	OFF

PIN DESCRIPTION		
Pin Number	Symbol	Description
1 - 4, 30 - 32	V_{IN}	Input-Voltage (High-Side MOSFET Drain)
5, 12	CGND	Control Ground. Should be connected to PGND externally
6, 7	C_{BOOT}	Connection pin for Bootstrap Capacitor for High-Side MOSFET
8, 9, 10	V_{DD}	Logic Supply Voltage - decoupling to GND with a CAP is strongly recommended
11	PMW	Pulse Width Modulation (PWM) Signal Input
13	SYNC	Disable Low-Side MOSFET Drive
14	SHDN	Disable All Functions (Active Low)
15 - 24	PGND	Power Ground (Low-Side MOSFET Source)
25 - 29	SW	Connection Pin for Output Inductor (High-Side MOSFET Source/Low-Side MOSFET Drain)

Vishay Siliconix

DEVICE OPERATION**Pulse Width Modular (PWM)**

This is a CMOS compatible logic input that receives the drive signals from the controller circuit. The PWM signal drives the buck switch.

Break-Before-Make (BBM)

The SiC730CD9 has an internal break-before-make function to ensure that both high-side and low-side MOSFETs are not turned on the same time. The low-side MOSFET will not turn on until the high-side gate drive voltage is less than VBBM, thus ensuring that the high-side MOSFET is turned off. This parameter is not user adjustable.

 $\overline{\text{SHDN}}$

CMOS logic signal. In the low state, the $\overline{\text{SHDN}}$ disables both high-side and low-side MOSFET's.

Capacitor to Boot Input (C_{BOOT})

Connected to V_{DD} by an internal diode via the C_{BOOT} pin, the boot capacitor is used to sustain rail for the high-side MOSFET gate drive circuit.

Under Voltage Lockout (UVLO)

During the start up cycle, the UVLO disables the gate drive holding high-side and low-side MOSFET's low until the input voltage rail has reached a point at which the logic circuitry can be safely activated. The UVLO is not user adjustable.

SYNC Pin for Pre-Bias Start-Up

The low side MOSFET can be individually enable or disabled by using the SYNC pin. In the low state (SYNC = low), the low-side MOSFET is turned off. In the high state, the low-side MOSFET is enabled and follows the PWM input signal (see timing diagram, Figure 2). SYNC is a CMOS compatible logic input and is used for a pre-biased output voltage.

Voltage Input (V_{IN})

This is the power input to the drain of the high-side Power MOSFET. This pin is connected to the high power intermediate BUS rail.

Switch Node (SW)

The Switch node is the circuit PWM regulated output. This is the output applied to the filter circuit to deliver the regulated high output for the buck converter.

Power Ground (PGND)

This is the output connection from the source of the low-side MOSFET. This output is the ground return loop for the power rail. It should be externally connected to CGND.

Control Ground (CGND)

This is the control voltage return path for the driver and logic input circuitry to the SiC730CD9. This should externally connected to PGND.

APPLICATION CIRCUIT

Power Up Sequence: The presence of V_{DD} prior to applying the V_{IN} and PWM is recommended to ensure a safe turn on

Power Down Sequence: The sequence should be reverse of the on sequence, turn off the V_{IN} before turning off the V_{DD} .

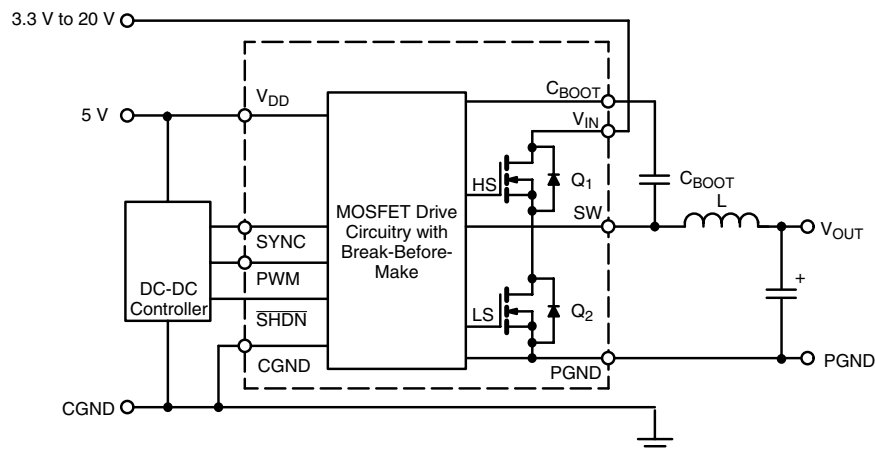

Figure 7.

The SiC734CD9 has a built-in delay time that is optimized for the MOSFET pair. When the PWM signal goes low, the high-side driver will turn off, after circuit delay (t_{doff}), and the output will start to ramp down, (t_f). After a further delay, the low-side driver turns on.

When the PWM goes high, the low-side driver turns off, (t_{don}). As the body diode starts to conduct, the high-side MOSFET turns on after a short delay. The delay is minimized to limit body diode conduction. The output then ramps up, (t_r).

TYPICAL APPLICATION

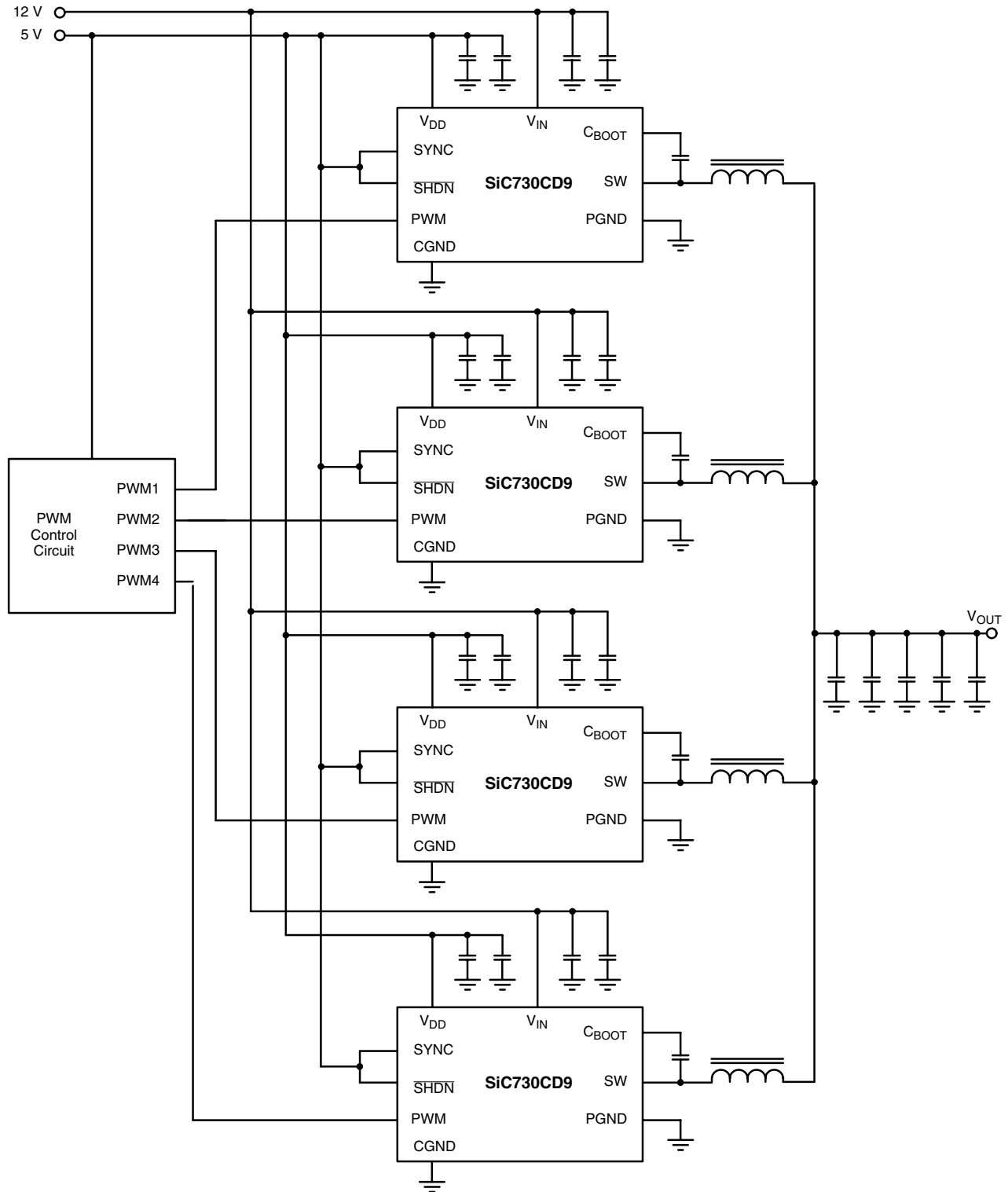

Figure 8

Vishay Siliconix maintains worldwide manufacturing capability. Products may be manufactured at one of several qualified locations. Reliability data for Silicon Technology and Package Reliability represent a composite of all qualified locations. For related documents such as package/tape drawings, part marking, and reliability data, see <http://www.vishay.com/ppg?73670>.



Notice

Specifications of the products displayed herein are subject to change without notice. Vishay Intertechnology, Inc., or anyone on its behalf, assumes no responsibility or liability for any errors or inaccuracies.

Information contained herein is intended to provide a product description only. No license, express or implied, by estoppel or otherwise, to any intellectual property rights is granted by this document. Except as provided in Vishay's terms and conditions of sale for such products, Vishay assumes no liability whatsoever, and disclaims any express or implied warranty, relating to sale and/or use of Vishay products including liability or warranties relating to fitness for a particular purpose, merchantability, or infringement of any patent, copyright, or other intellectual property right.

The products shown herein are not designed for use in medical, life-saving, or life-sustaining applications. Customers using or selling these products for use in such applications do so at their own risk and agree to fully indemnify Vishay for any damages resulting from such improper use or sale.