

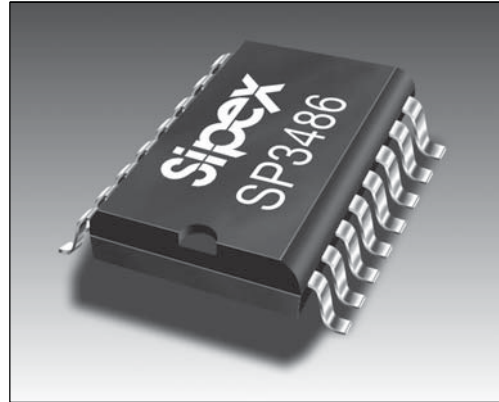

SP3486 and SP3487

+3.3V Low Power Quad RS-485/RS-422 Line Drivers

- RS-485 or RS-422 Quad Differential Line Drivers
- Operates from a single +3.3V supply
- Interoperable with +5.0V logic
- Tri-state Output Control
- -7V to +12V Common-Mode Input Voltage Range
- Common Driver Enable Control (**SP3486**)
- Independent Driver Enable Controls for each pair of Drivers (**SP3487**)
- Compatibility with LTC486 and SN75172 (**SP3486**)
- Compatibility with LTC487 and SN75174 (**SP3487**)



Now Available in Lead Free Packaging

DESCRIPTION

The **SP3486** and the **SP3487** are +3.3V low power quad drivers that meet the specifications of the RS-485 and RS-422 serial protocols. These devices are pin-to-pin compatible with Sipex's SP486 and SP487 devices as well as popular industry standards. The **SP3486** and **SP3487** feature Sipex's BiCMOS process allowing low power operation without sacrificing performance. The **SP3486** and **SP3487** meet the electrical specifications of RS-485 and RS-422 serial protocols up to 10Mbps under load. The SP3486 features a common driver enable control. The **SP3487** provides independent driver enable controls for each pair of drivers. Both devices feature tri-state outputs and a -7V to +12V common-mode input voltage range.

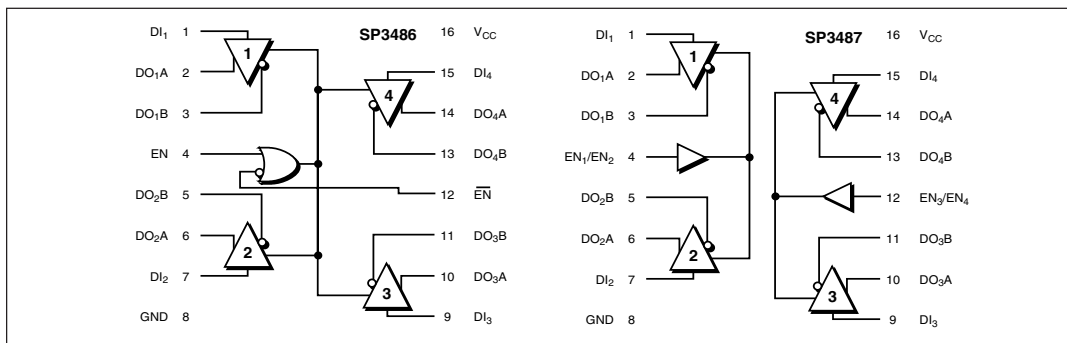

ABSOLUTE MAXIMUM RATINGS

These are stress ratings only and functional operation of the device at these or any other above those indicated in the operation sections of the specifications below is not implied. Exposure to absolute maximum rating conditions for extended periods of time may affect reliability.

V_{CC}	+6.0V
Input Voltages	
Logic	-0.3V to +6.0V
Drivers	-0.3V to +6.0V
Driver Output Voltage	$\pm 14V$
Input Currents	
Logic	$\pm 25mA$
Driver	$\pm 25mA$
Storage Temperature	$-65^{\circ}C$ to $+150^{\circ}C$
Power Dissipation	
Plastic DIP	375mW
(derate 7mW/ $^{\circ}C$ above $+70^{\circ}C$)	
Small Outline	375mW
(derate 7mW/ $^{\circ}C$ above $+70^{\circ}C$)	
Lead Temperature (soldering, 10 sec)	$300^{\circ}C$



CAUTION:
ESD (ElectroStatic Discharge) sensitive device. Permanent damage may occur on unconnected devices subject to high energy electrostatic fields. Unused devices must be stored in conductive foam or shunts. Personnel should be properly grounded prior to handling this device. The protective foam should be discharged to the destination socket before devices are removed.

SPECIFICATIONS

$V_{CC} = 3.3V \pm 5\%$; typicals at $25^{\circ}C$; $T_{MIN} \leq T_A \leq T_{MAX}$ unless otherwise noted.

PARAMETER	MIN.	TYP.	MAX.	UNIT	CONDITIONS
DC CHARACTERISTICS					
Digital Inputs					DI, EN, \overline{EN} , EN ₁ /EN ₂ , EN ₃ /EN ₄
Voltage			0.8	Volts	
V_{IL}	2.0			Volts	
V_{IH}				Volts	
Input Current			± 2	μA	$V_{IN} = 0V$ to V_{CC}
DRIVER OUTPUTS					
Differential Voltage	2		V_{CC}	Volts	unloaded
	1.5		V_{CC}	Volts	R = 50 Ω (RS-422)
				Volts	R = 27 Ω (RS-485); <i>Figure 1</i>
Common Mode Output Voltage			3	Volts	R = 27 Ω or 50 Ω ; <i>Figure 1</i>
Change in Common Mode Output Magnitude for Complementary Output State			0.2	Volts	R = 27 Ω or 50 Ω ; <i>Figure 1</i>
				Volts	R = 50 Ω (RS-422)
				Volts	R = 27 Ω (RS-485)
Maximum Data Rate	10			Mbps	
Short-circuit Current			± 250	mA	$-7V \leq V_O \leq +12V$
V_{OH}			± 250	mA	$-7V \leq V_O \leq +12V$
V_{OL}			1	μA	$V_O = -7V$ to $+12V$, $T_A = 25^{\circ}C$
High Impedance Output Current					
POWER REQUIREMENTS					
Supply Voltage	3.00	3.30	3.60	Volts	
Supply Current		3.00		μA	No load, output enabled
		0.10		μA	No load, output disabled
ENVIRONMENTAL AND MECHANICAL					
Operating Temperature					
-C	0		+70	$^{\circ}C$	
-E	-40		+85	$^{\circ}C$	
Storage Temperature	-65		+150	$^{\circ}C$	
Package					
-P	16-pin Plastic DIP				
-T	16-pin SOIC				

PINOUT — SP3486

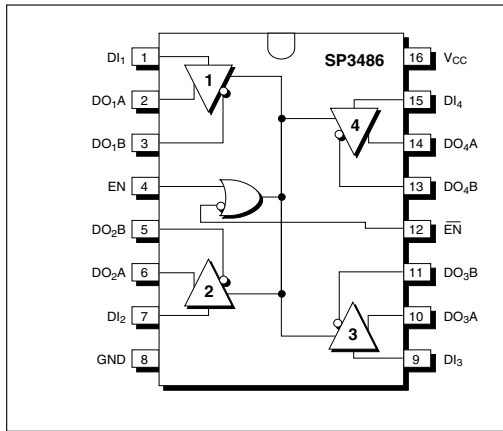

SP3486 PINOUT

Pin 1 — DI₁ — Driver 1 Input — If Driver 1 output is enabled, logic 0 on DI₁ forces driver output DO_{1A} low and DO_{1B} high. A logic 1 on DI₁ with Driver 1 output enabled forces driver DO_{1A} high and DO_{1B} low.

Pin 2 — DO_{1A} — Driver 1 output A.

Pin 3 — DO_{1B} — Driver 1 output B.

Pin 4 — EN — Driver Output Enable. Please refer to SP3486 *Truth Table (1)*.

Pin 5 — DO_{2B} — Driver 2 output B.

Pin 6 — DO_{2A} — Driver 2 output A.

Pin 7 — DI₂ — Driver 2 Input — If Driver 2 output is enabled, logic 0 on DI₂ forces driver output DO_{2A} low and DO_{2B} high. A logic 1 on DI₂ with Driver 2 output enabled forces driver DO_{2A} high and DO_{2B} low.

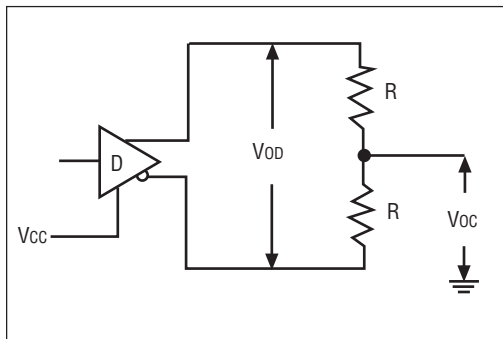

Figure 1. Driver DC Test Load Circuit

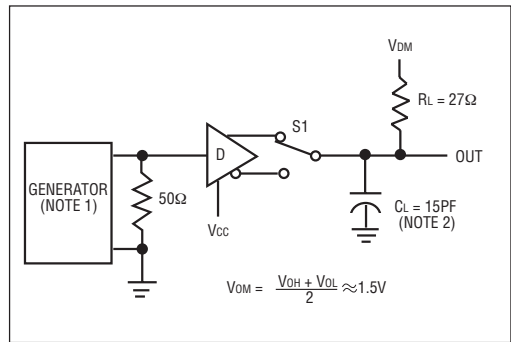

Figure 2. Driver Propagation Delay Test Circuit

Pin 8 — GND — Digital Ground.

Pin 9 — DI₃ — Driver 3 Input — If Driver 3 output is enabled, logic 0 on DI₃ forces driver output DO_{3A} low and DO_{3B} high. A logic 1 on DI₃ with Driver 3 output enabled forces driver DO_{3A} high and DO_{3B} low.

Pin 10 — DO_{3A} — Driver 3 output A.

Pin 11 — DO_{3B} — Driver 3 output B.

Pin 12 — \overline{EN} — Driver Output Disable. Please refer to SP486 *Truth Table (1)*.

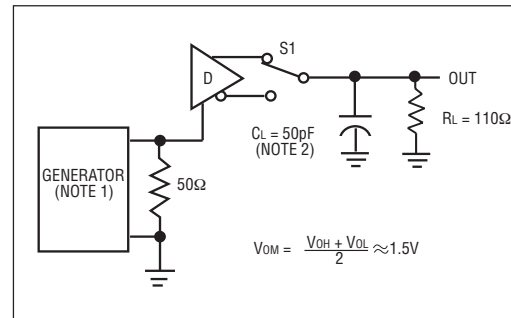

Figure 3. Driver Enable and Disable Timing Circuit, Output HIGH

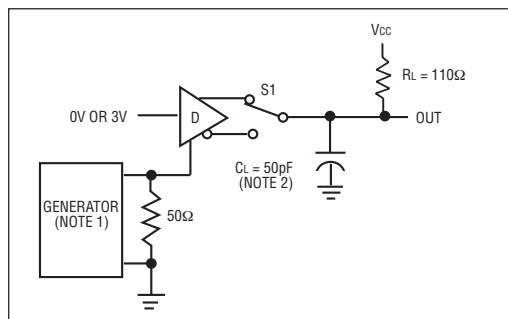
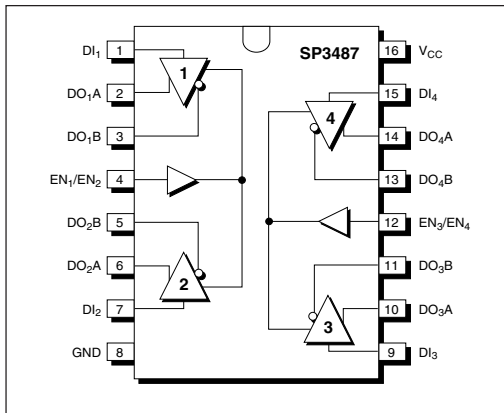

Figure 4. Driver Enable and Disable Timing Circuit, Output LOW

PINOUT — SP3487



Pin 13 — DO₄B — Driver 4 output B.

Pin 14 — DO₄A — Driver 4 output A.

Pin 15 — DI₄ — Driver 4 Input — If Driver 4 output is enabled, logic 0 on DI₄ forces driver output DO₄A low and DO₄B high. A logic 1 on DI₄ with Driver 4 output enabled forces driver DO₄A high and DO₄B low.

Pin 16 — V_{CC} — Positive Supply +3.00V < V_{CC} < +3.60V

SP3487 PINOUT

Pin 1 — DI₁ — Driver 1 Input — If Driver 1 output is enabled, logic 0 on DI₁ forces driver output DO₁A low and DO₁B high. A logic 1 on DI₁ with Driver 1 output enabled forces driver DO₁A high and DO₁B low.

Pin 2 — DO₁A — Driver 1 output A.

Pin 3 — DO₁B — Driver 1 output B.

Pin 4 — EN₁/EN₂ — Driver 1 and 2 Output Enable. Please refer to SP3487 Truth Table (2).

Pin 5 — DO₂B — Driver 2 output B.

Pin 6 — DO₂A — Driver 2 output A.

Pin 7 — DI₂ — Driver 2 Input — If Driver 2 output is enabled, logic 0 on DI₂ forces driver output DO₂A low and DO₂B high. A logic 1 on DI₂ with Driver 2 output enabled forces driver DO₂A high and DO₂B low.

INPUT	ENABLES		OUTPUTS	
DI	EN	$\overline{\text{EN}}$	OUTA	OUTB
H	H	X	H	L
L	H	X	L	H
H	X	L	H	L
L	X	L	L	H
X	L	H	Hi-Z	Hi-Z

Table 1. SP3486 Truth Table

Pin 8 — GND — Digital Ground.

Pin 9 — DI₃ — Driver 3 Input — If Driver 3 output is enabled, logic 0 on DI₃ forces driver output DO₃A low and DO₃B high. A logic 1 on DI₃ with Driver 3 output enabled forces driver DO₃A high and DO₃B low.

Pin 10 — DO₃A — Driver 3 output A.

Pin 11 — DO₃B — Driver 3 output B.

Pin 12 — EN₃/EN₄ — Driver 3 and 4 Output Enable. Please refer to SP3487 Truth Table (2).

Pin 13 — DO₄B — Driver 4 output B.

Pin 14 — DO₄A — Driver 4 output A.

Pin 15 — DI₄ — Driver 4 Input — If Driver 4 output is enabled, logic 0 on DI₄ forces driver output DO₄A low and DO₄B high. A logic 1 on DI₄ with Driver 4 output enabled forces driver DO₄A high and DO₄B low.

Pin 16 — V_{CC} — Positive Supply +3.00V < V_{CC} < +3.60V

INPUT	ENABLES	OUTPUTS	
DI	EN1/EN2 or EN3/EN4	OUTA	OUTB
H	H	H	L
L	H	L	H
X	L	Hi-Z	Hi-Z

Table 2. SP3487 Truth Table

FEATURES

The **SP3486** and the **SP3487** are +3.3V low power quad line drivers that meet the specifications of the RS-485 and RS-422 serial protocols. These devices are pin-to-pin compatible with Sipex's SP486 and SP487 devices as well as popular industry standards. The **SP3486** and **SP3487** devices feature Sipex's BiCMOS process allowing low power operation without sacrificing performance.

The RS-485 standard is ideal for multi-drop applications or for long distance interfaces. RS-485 allows up to 32 drivers and 32 receivers to be connected to a data bus, making it an ideal choice for multi-drop applications. Since the cabling can be as long as 4,000 feet, RS-485 transceivers are equipped with a wide (-7V to +12V) common mode range to accommodate ground potential differences. Data is virtually immune to noise in the transmission line because the RS-485 protocol is a differential interface.

Driver

The drivers for both the **SP3486** and **SP3487** have differential outputs. The typical voltage output swing with no load will be 0V to +5V. With worst case loading of 54Ω across the differential outputs, the driver can maintain greater than +1.5V voltage levels.

The drivers of the **SP3486** feature active HIGH and active LOW common driver enable controls. Refer to **SP3486** Truth Table in Table 1. The **SP3487** provides independent, active high driver enable controls for each pair of drivers. Refer to **SP3487** Truth Table in Table 2. The driver outputs are short-circuit limited to 250mA. The **SP3486** and **SP3487** drivers meet the electrical specifications of RS-485 and RS-422 serial protocols up to 10Mbps under load.

AC PARAMETERS

$V_{CC} = +3.3V \pm 5\%$; typicals at 25°C; $T_{AMB} = 25^\circ C$ unless otherwise noted.

PARAMETER	MIN.	TYP.	MAX.	UNIT	CONDITIONS
PROPAGATION DELAY Driver Input to Output					<i>Figure 2 and 5</i>
Low to High (t_{PLH})	20	40	60	ns	
High to Low (t_{PHL})	20	40	60	ns	
Differential Driver Skew		5	10	ns	$ t_{PHL}(Y) - t_{PLH}(Y) , t_{PHL}(Z) - t_{PLH}(Z) ,$ <i>Figures 2 and 5</i>
Driver Rise Time (t_R)					10% to 90% $R_{DIFF} = 60\Omega$
SP3486		10		ns	
SP3487		10		ns	
Driver Fall Time (t_F)					90% to 10% $R_{DIFF} = 60\Omega$
SP3486		10		ns	
SP3487		10		ns	
DRIVER ENABLE To Output High		110		ns	<i>Figures 3 and 6</i>
To Output Low		110		ns	<i>Figures 4 and 6</i>
DRIVER DISABLE From Output Low		110		ns	<i>Figures 4 and 6</i>
From Output High		110		ns	<i>Figures 3 and 6</i>

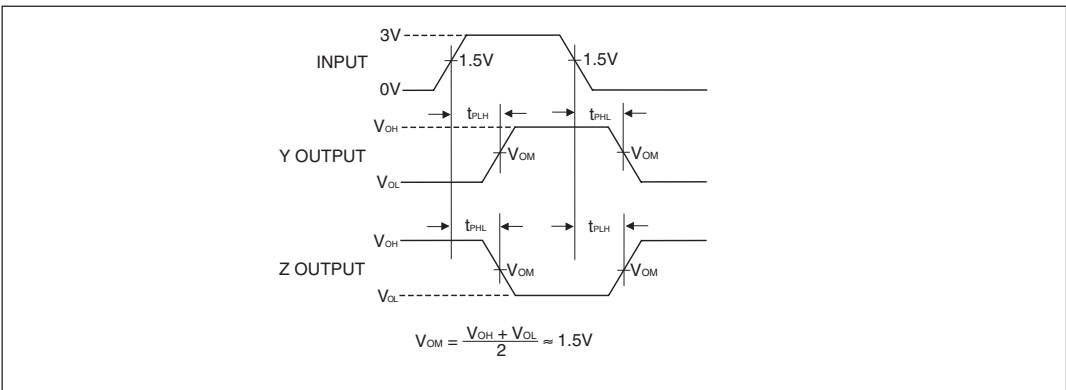

Figure 5. Driver Propagation Delay Waveforms

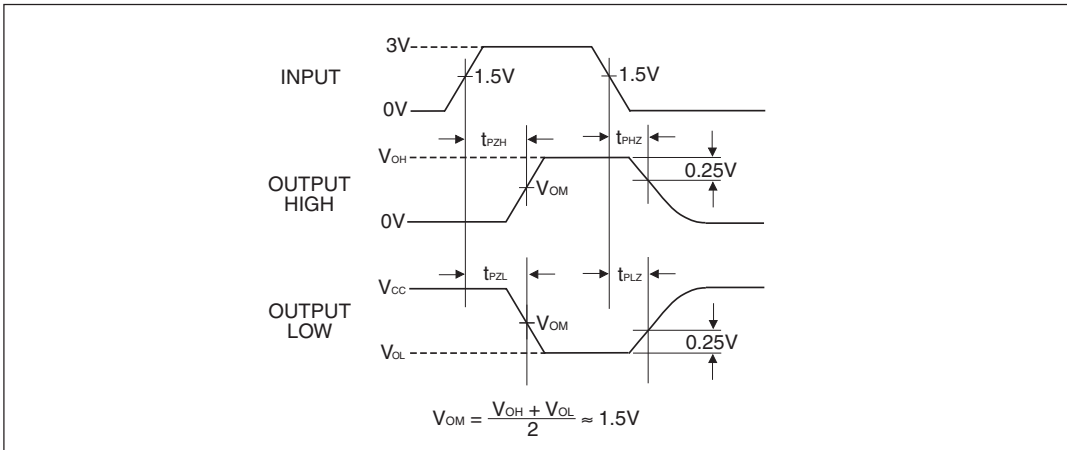

Figure 6. Driver Enable and Disable Timing Waveforms

NOTE 1: The input pulse is supplied by a generator with the following characteristics:

INPUT=250kHz, 50% duty cycle, $t_r \leq 6.0ns$, $Z_o = 50\Omega$.

NOTE 2: C_L includes probe and stray capacitance.

PACKAGE: 16 PIN PDIP

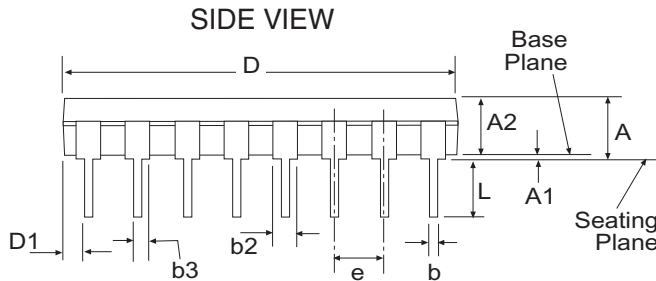
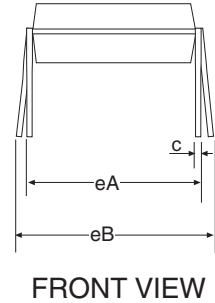
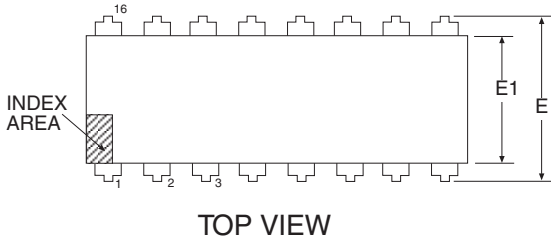

PDIP JEDEC MS-001 VARIATION BB N = 16 Pins						
SYMBOL	Dimensions in Inches: Controlling Dimension			Dimensions in Millimeters Conversion Factor: 1 Inch = 25.40 mm		
	MIN	NOM	MAX	MIN	NOM	MAX
A	-	-	0.210	-	-	5.33
A1	0.015	-	-	0.38	-	-
A2	0.115	0.130	0.195	2.92	3.30	4.95
b	0.014	0.018	0.022	0.36	0.46	0.56
b2	0.045	0.060	0.070	1.14	1.52	1.78
b3	0.030	0.039	0.045	0.76	0.99	1.14
c	0.008	0.010	0.014	0.20	0.25	0.36
D1	0.005	-	-	0.00	-	-
E	0.300	0.310	0.325	7.62	7.87	8.26
E1	0.240	0.250	0.280	6.10	6.35	7.11
e	0.100 BSC			0.004 BSC		
eA	0.300 BSC			0.012 BSC		
eB	-	-	0.430	-	-	10.92
L	0.115	0.130	0.150	2.92	3.30	3.81
D	0.735	0.755	0.775	18.67	19.18	19.69
SIPEX Pkg Signoff Date/Rev:				JL Nov21-05/ Rev A		

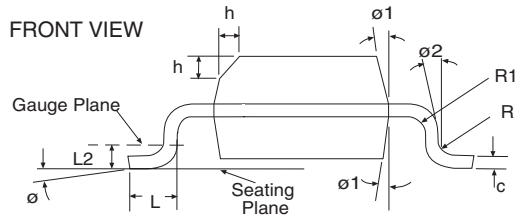
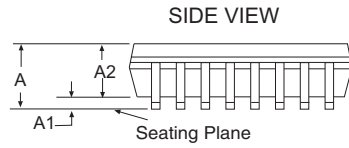
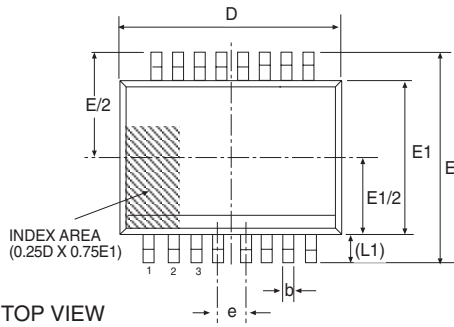

16 PIN WSOIC		JEDEC MS-013			Variation AA		
SYMBOL	Dimensions in Millimeters: Controlling Dimension			Dimensions in Inches Conversion Factor: 1 Inch = 25.40 mm			
	MIN	NOM	MAX	MIN	NOM	MAX	
A	2.35	-	2.65	0.093	-	0.104	
A1	0.10	-	0.30	0.004	-	0.012	
A2	2.05	-	2.55	0.081	-	0.100	
b	0.31	-	0.51	0.012	-	0.020	
c	0.20	-	0.33	0.008	-	0.013	
E	10.30 BSC			0.406 BSC			
E1	7.50 BSC			0.295 BSC			
e	1.27 BSC			0.050 BSC			
h	0.25	-	0.75	0.010	-	0.030	
L	0.40	-	1.27	0.016	-	0.050	
L1	1.40 REF			0.055 REF			
L2	0.25 BSC			0.010 BSC			
R	0.07	-	-	0.003	-	-	
R1	0.07	-	-	0.003	-	-	
ø	0°	-	8°	0°	-	8°	
ø1	5°	-	15°	5°	-	15°	
ø2	0°	-	-	0°	-	-	
D	10.30 REF			0.405 REF			
SIPEX Pkg Signoff Date/Rev:				JL Oct11-05/ Rev A			

ORDERING INFORMATION

Quad RS485 Drivers:

Model	Enable/Disable	Temperature Range	Package
SP3486CP	Common; active Low and Active High	0°C to +70°C	16-pin Plastic DIP
SP3486CT	Common; active Low and Active High	0°C to +70°C	16-pin WSOIC
SP3486EP	Common; active Low and Active High	-40°C to +85°C	16-pin Plastic DIP
SP3486ET	Common; active Low and Active High	-40°C to +85°C	16-pin WSOIC
SP3487CP	One per driver pair; active High	0°C to +70°C	16-pin Plastic DIP
SP3487CT	One per driver pair; active High	0°C to +70°C	16-pin WSOIC
SP3487EP	One per driver pair; active High	-40°C to +85°C	16-pin Plastic DIP
SP3487ET	One per driver pair; active High	-40°C to +85°C	16-pin WSOIC

Please consult the factory for pricing and availability on a Tape-On-Reel option.

Now available in Lead Free. To order add “-L’ to the part number.

Example: SP3487CT = normal, SP3487CT-L = Lead free.

Note: SP3486 is **not recommended** for new designs. Contact factory for availability options.



SIGNAL PROCESSING EXCELLENCE

Sipex Corporation

Headquarters and Sales Office

233 South Hillview Drive
Milpitas, CA 95035
TEL: (408) 934-7500
FAX: (408) 935-7600

Sales Office

22 Linnell Circle
Billerica, MA 01821
TEL: (978) 667-8700
FAX: (978) 670-9001
e-mail: sales@sipex.com

Sipex Corporation reserves the right to make changes to any products described herein. Sipex does not assume any liability arising out of the application or use of any product or circuit described hereing; neither does it convey any license under its patent rights nor the rights of others.