

# Advanced Analog

a division of Intech

## ATW2800S Series Hybrid - High Reliability DC/DC Converters

### DESCRIPTION

The ATW2800S Series of DC/DC converters feature high power density and an extended temperature range for use in military and industrial applications. Designed to meet the nominal input requirements of MIL-STD-704D, these devices have nominal 28 VDC inputs with +5 V, +12 V and +15 V single outputs. The circuit design incorporates a pulse width modulated push-pull topology operating in the feed-forward mode at a nominal switching frequency of 270 kHz. Input to output isolation is achieved through the use of transformers in the forward and feedback circuits.

The advanced feedback design provides fast loop response for superior line and load transient characteristics and offers greater reliability and radiation tolerance than devices incorporating optical feedback circuits.

Three standard temperature grades are offered. Refer to Part Number section. They are provided in a flanged package for more severe environments.

These converters are manufactured in a facility fully qualified to Mil-Std-1772. All processes used to manufacture these converters have been qualified to enable Advanced Analog to deliver compliant devices. Two screening grades are available to satisfy a wide range of requirements. The CH grade converters are fully compliant to Mil-Std-1772 class B. The HB grade converters are processed to full class B screening but do not have class B element evaluation as required by Mil-Std-1772. Both grades are fully tested and operate over the full military temperature range without derating of output power. Variations in electrical, mechanical and screening can be accommodated. Extensive computer simulation using complex modeling enables rapid design modification to be provided. Contact Advanced Analog with specific requirements.

### FEATURES

- 19 - 40 Vdc input range (28 Vdc nominal)
- 30 watts output power
- Indefinite short circuit and overload protection
- 22.8 W/in<sup>3</sup> power density
- Fast loop response for superior transient characteristics
- Operating temperature range from -55° C - +125° C available
- Popular industry standard pinout
- Resistance seam welded case for superior long term hermeticity
- Efficiencies up to 83%
- Shutdown from external signal
- Military screening
- 250,000 hour MTBF at 85° C

## SPECIFICATIONS

$T_{CASE} = -55^{\circ}\text{C}$  to  $+85^{\circ}\text{C}$ ,  $V_{IN} = +28\text{ V} \pm 5\%$  unless otherwise specified.

ABSOLUTE MAXIMUM RATINGS	
Input Voltage <sup>1</sup>	-0.5 V to +50 V
Power Output	Internally limited, 38 W typical
Soldering	300°C for 10 seconds
Temperature Range <sup>1</sup>	Operating -55 °C +115°C case Storage -65 °C +135°C

Parameter	Conditions	ATW2805S			ATW2812S			ATW2815S			Units
		Min	Typ	Max	Min	Typ	Max	Min	Typ	Max	
<b>STATIC CHARACTERISTICS</b>	$V_{IN} = 18$ to $40\text{ Vdc}$ (12S/15S)										
OUTPUT	$V_{IN} = 19$ to $40\text{ Vdc}$ (05S)										
Voltage	$I_{OUT} = 0$ to Full Load	4.90	5.00	5.10	11.76	12.00	12.24	14.70	15.00	15.30	V <sub>DC</sub>
Current		0.0		6000	0.0		2500	0.0		2000	mADC
Ripple Voltage	Full Load, DC to 2 MHz		15	50		15	50		15	50	mV p-p
Accuracy	$T_{CASE} = 25^{\circ}\text{C}$	4.95	5.00	5.05	11.88	12.00	12.12	14.85	15.00	15.15	V <sub>DC</sub>
Power <sup>1</sup>		30			30			30			W
REGULATION	$V_{IN} = 18$ to $40\text{ Vdc}$ (12S/15S)										
Line <sup>4</sup>	$V_{IN} = 19$ to $40\text{ Vdc}$ (05S)		$\pm 5$	$\pm 20$		$\pm 5$	$\pm 60$		$\pm 5$	$\pm 75$	mV
Load <sup>4</sup>	$I_{OUT} = 0$ to Full Load		$\pm 5$	$\pm 30$		$\pm 20$	$\pm 120$		$\pm 20$	$\pm 150$	mV
INPUT											
Voltage Range <sup>4</sup>	No Load	19.0	28.0	40.0	18.0	28.0	40.0	18.0	28.0	40.0	V <sub>DC</sub>
Current	Inhibited		25	40		25	40		25	40	mADC
Ripple Current	Full Load, BW $\leq 2\text{ MHz}$		5	18		5	18		5	18	mADC
EFFICIENCY	$T_{CASE} = +25^{\circ}\text{C}$										
	Half Load to Full Load	78	80		80	82		80	83		%
CAPACITIVE LOAD	No effect on performance			500			200			200	$\mu\text{F}$
LOAD FAULT POWER DISSIPATION ( $T_{CASE} = +25^{\circ}\text{C}$ )	Short circuit			9			9			9	W
	Overload			12			12			12	W
ISOLATION	Input to Output @ 500 Vdc	100			100			100			M $\Omega$
<b>DYNAMIC CHARACTERISTICS</b>											
STEP LOAD CHANGES	$T_{CASE} = +25^{\circ}\text{C}$										
Output Transient	50% Load $\leftrightarrow$ 100% Load		$\pm 400$			$\pm 400$			$\pm 400$		mVpk
	No Load $\rightarrow$ 50% Load		$\pm 600$			$\pm 600$			$\pm 600$		mVpk
	50% Load $\rightarrow$ No Load		$\pm 300$			$\pm 400$			$\pm 400$		mVpk
Recovery <sup>2</sup>	50% Load $\leftrightarrow$ 100% Load		25			25			25		$\mu\text{s}$
	No Load $\rightarrow$ 50% Load		200			300			300		$\mu\text{s}$
	50% Load $\rightarrow$ No Load		4			4			4		ms
STEP LINE CHANGES	$T_{CASE} = +25^{\circ}\text{C}$										
Output Transient	Input step 19 to 40 Vdc		+200			+200			+200		mVpk
	Input step 40 to 19 Vdc		-700			-700			-700		mVpk
Recovery <sup>2</sup>	Input step 19 to 40 Vdc		150			150			150		$\mu\text{s}$
	Input step 40 to 19 Vdc		200			200			200		$\mu\text{s}$
TURN-ON											
Overshoot	$I_{OUT} = 0$ to Full Load		200	500		0	600		0	750	mVpk
Delay <sup>3</sup>			6	12		7	12		7	12	ms
LOAD FAULT RECOVERY			6	12		7	12		7	12	ms
Weight	Flange			75			75			75	Grams

Notes:

- Above  $+85^{\circ}\text{C}$  case, derate output power linearly to 0 at  $+115^{\circ}\text{C}$  case.
- Recovery time is measured from the initiation of the input/output transient to where  $V_{OUT}$  has returned to within  $\pm 1\%$  of  $V_{OUT}$  at 50% load. See typical waveforms.
- Turn-on delay time measurement is for either an application of power at the input or a signal at the shutdown pin.
- Output voltage measured at load with remote sense leads connected across load for ATW2805S.

# SPECIFICATIONS

T<sub>case</sub> = -55°C to +105°C, V<sub>in</sub> = +28 V ±5% unless otherwise specified.

ABSOLUTE MAXIMUM RATINGS	
Input Voltage <sup>1</sup>	-0.5 V to +50 V
Power Output	Internally limited, 38 W typical
Soldering	300°C for 10 seconds
Temperature Range <sup>1</sup>	Operating -55°C +115°C case Storage -65°C +135°C

Parameter	Conditions	ATW2805S/ES			ATW2812S/ES			ATW2815S/ES			Units
		Min	Typ	Max	Min	Typ	Max	Min	Typ	Max	
<b>STATIC CHARACTERISTICS</b>											
VIN = 18 to 40 Vdc (12S/15S)											
OUTPUT	VIN = 19 to 40 Vdc (05S)										
Voltage	I <sub>OUT</sub> = 0 to Full Load	4.90	5.00	5.10	11.76	12.00	12.24	14.70	15.00	15.30	Vdc
Current		0.0		6000	0.0		2500	0.0		2000	mAdc
Ripple Voltage	Full Load, DC to 2 MHz		15	50		15	50		15	50	mV p-p
Accuracy	T <sub>case</sub> = 25°C	4.95	5.00	5.05	11.88	12.00	12.12	14.85	15.00	15.15	Vdc
Power <sup>1</sup>		30			30			30			W
REGULATION	VIN = 18 to 40 Vdc (12S/15S)										
Line <sup>4</sup>	VIN = 19 to 40 Vdc (05S)		±5	±20		±5	±60		±5	±75	mV
Load <sup>4</sup>	I <sub>OUT</sub> = 0 to Full Load		±5	±30		±20	±120		±20	±150	mV
INPUT											
Voltage Range <sup>4</sup>	No Load	19.0	28.0	40.0	18.0	28.0	40.0	18.0	28.0	40.0	Vdc
Current	Inhibited		25	40		25	40		25	40	mAdc
Ripple Current	Full Load, BW ≤ 2 MHz		5	18		5	18		5	18	mAdc
EFFICIENCY	T <sub>case</sub> = +25°C	78	80		80	82		80	83		%
	Half Load to Full Load										
CAPACITIVE LOAD	No effect on performance			500			200			200	µF
LOAD FAULT POWER	Short circuit			9			9			9	W
DISSIPATION (T <sub>case</sub> = +25°C)	Overload			12			12			12	W
ISOLATION	Input to Output @ 500 Vdc	100			100			100			MΩ
<b>DYNAMIC CHARACTERISTICS</b>											
STEP LOAD CHANGES	T <sub>case</sub> = +25°C										
Output Transient	50% Load ↔ 100% Load		±400			±400			±400		mVpk
	No Load → 50% Load		±600			±600			±600		mVpk
Recovery <sup>2</sup>	50% Load → No Load		±300			±400			±400		mVpk
	50% Load ↔ 100% Load		25			25			25		µs
	No Load → 50% Load		200			300			300		µs
	50% Load → No Load		4			4			4		ms
STEP LINE CHANGES	T <sub>case</sub> = +25°C										
Output Transient	Input step 19 to 40 Vdc		+200			+200			+200		mVpk
	Input step 40 to 19 Vdc		-700			-700			-700		mVpk
Recovery <sup>2</sup>	Input step 19 to 40 Vdc		150			150			150		µs
	Input step 40 to 19 Vdc		200			200			200		µs
TURN-ON											
Overshoot	I <sub>OUT</sub> = 0 to Full Load		200	500		0	600		0	750	mVpk
Delay <sup>3</sup>			6	12		7	12		7	12	ms
LOAD FAULT RECOVERY			6	12		7	12		7	12	ms
Weight	Flange			75			75			75	Grams

**Notes:**

- Above +105°C case, derate output power linearly to 0 at +125°C case.
- Recovery time is measured from the initiation of the input/output transient to where V<sub>OUT</sub> has returned to within ±1% of V<sub>OUT</sub> at 50% load. See typical waveforms.
- Turn-on delay time measurement is for either an application of power at the input or a signal at the shutdown pin.
- Output voltage measured at load with remote sense leads connected across load for ATW2805S.

## SPECIFICATIONS

T<sub>CASE</sub> = -55°C to +125°C, V<sub>IN</sub> = +28 V ±5% unless otherwise specified.

### ABSOLUTE MAXIMUM RATINGS

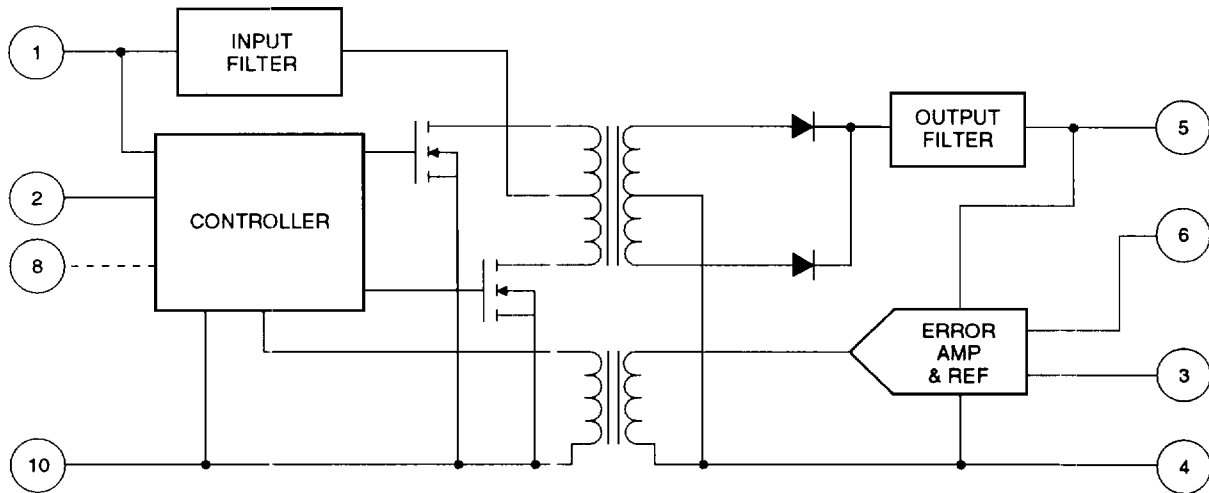
Input Voltage <sup>1</sup>	-0.5 V to +50 V
Power Output	Internally limited, 38 W typical
Soldering	300°C for 10 seconds
Temperature Range <sup>1</sup>	Operating -55°C: +115°C case Storage -65°C: +135°C

Parameter	Conditions	ATW2805S/HB			ATW2812S/HB			ATW2815S/HB			Units
		Min	Typ	Max	Min	Typ	Max	Min	Typ	Max	
<b>STATIC CHARACTERISTICS</b> V <sub>IN</sub> = 18 to 40 V <sub>DC</sub> (12S/15S)											
OUTPUT	V <sub>IN</sub> = 19 to 40 V <sub>DC</sub> (05S)										
Voltage	I <sub>OUT</sub> = 0 to Full Load	4.90	5.00	5.10	11.76	12.00	12.24	14.70	15.00	15.30	V <sub>DC</sub>
Current		0.0		6000	0.0		2500	0.0		2000	mA <sub>DC</sub>
Ripple Voltage	Full Load, DC to 2 MHz		15	50		15	50		15	50	mV p-p
Accuracy	T <sub>CASE</sub> = 25°C	4.95	5.00	5.05	11.88	12.00	12.12	14.85	15.00	15.15	V <sub>DC</sub>
Power <sup>1</sup>		30			30			30			W
REGULATION	V <sub>IN</sub> = 18 to 40 V <sub>DC</sub> (12S/15S)										
L <sub>no</sub> <sup>4</sup>	V <sub>IN</sub> = 19 to 40 V <sub>DC</sub> (05S)		±5	±20		±5	±60		±5	±75	mV
L <sub>load</sub> <sup>4</sup>	I <sub>OUT</sub> = 0 to Full Load		±5	±30		±20	±120		±20	±150	mV
INPUT											
Voltage Range <sup>4</sup>	No Load	19.0	28.0	40.0	18.0	28.0	40.0	18.0	28.0	40.0	V <sub>DC</sub>
Current	Inhibited		25	40		25	40		25	40	mA <sub>DC</sub>
Ripple Current	Full Load, BW ≤ 2 MHz		5	18		5	18		5	18	mA p-p
				20			20			20	
EFFICIENCY	T <sub>CASE</sub> = +25°C	78	80		80	82		80	83		%
	Half Load to Full Load										
CAPACITIVE LOAD	No effect on performance			500			200			200	μF
LOAD FAULT POWER DISSIPATION (T <sub>CASE</sub> = +25°C)	Short circuit			9			9			9	W
	Overload			12			12			12	W
ISOLATION	Input to Output @ 500 V <sub>DC</sub>	100			100			100			MΩ
<b>DYNAMIC CHARACTERISTICS</b>											
STEP LOAD CHANGES	T <sub>CASE</sub> = +25°C										
Output Transient	50% Load ↔ 100% Load		±400	±600		±400	±800		±400	±800	mVpk
	No Load → 50% Load		±600	±1000		±600	±1000		±600	±1000	mVpk
	50% Load → No Load		±300	±500		±400	±750		±400	±750	mVpk
F <sub>recovery</sub> <sup>2</sup>	50% Load ↔ 100% Load		25	100		25	100		25	100	μs
	No Load → 50% Load		200	400		300	1000		300	1000	μs
	50% Load → No Load		4	5		4	5		4	5	ms
STEP LINE CHANGES	T <sub>CASE</sub> = +25°C										
Output Transient	Input step 19 to 40 V <sub>DC</sub>		+200			+200			+200		mVpk
	Input step 40 to 19 V <sub>DC</sub>		-700			-700			-700		mVpk
F <sub>recovery</sub> <sup>2</sup>	Input step 19 to 40 V <sub>DC</sub>		150			150			150		μs
	Input step 40 to 19 V <sub>DC</sub>		200			200			200		μs
TURN-ON											
Overshoot	I <sub>OUT</sub> = 0 to Full Load		200	500		0	600		0	750	mVpk
Delay <sup>3</sup>			6	12		7	12		7	12	ms
LOAD FAULT RECOVERY			6	12		7	12		7	12	ms
Weight	Flange			75			75			75	Grams

#### Notes:

- Above +125°C case, derate output power linearly to 0 at +135°C case.
- F<sub>recovery</sub> time is measured from the initiation of the input/output transient to where V<sub>OUT</sub> has returned to within ±1% of V<sub>OUT</sub> at 50% load. See typical waveforms.
- Turn-on delay time measurement is for either an application of power at the input or a signal at the shutdown pin.
- Output voltage measured at load with remote sense leads connected across load for ATW2805S.

## BLOCK DIAGRAM



## PIN DESIGNATION

Pin 1 Positive input	Pin 10 Input common
Pin 2 Inhibit input	Pin 9 N/C
Pin 3 Neg. remote sense*	Pin 8 N/C**
Pin 4 Output common	Pin 7 Case ground
Pin 5 Positive output	Pin 6 Pos. remote sense*

\*ATW2805S only. ATW2812S, ATW2815S have N/C.  
 \*\*Or synchronization option.

## HB SCREENING PROCESS Per MIL-STD-883C

Test Inspection	Method	Condition
Pre-Seal Internal Visual	2017	
Stabilization Bake	1008	C
Temperature Cycling	1010	C
Constant Acceleration	2001	A, Y1 direction
Burn-in	1015	Tc = +125°C
Final Electrical Test		Tc = -55,+25,+125°C
External Visual	2009	
Gross Leak	1014	C
Fine Leak	1014	A

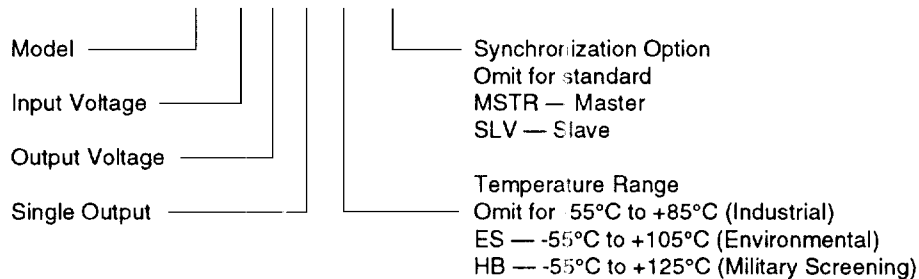
## ES SCREENING PROCESS

Same as HB screening except as follows:

Test Inspection	Method
Constant Acceleration	2001, 500g's
Burn-in	1015, 96 hrs.
Final Electrical	25°C only

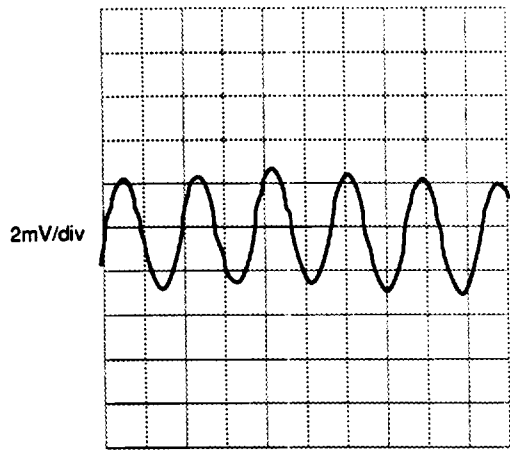
## PART NUMBER

**ATW 28xx S / x - xxx**

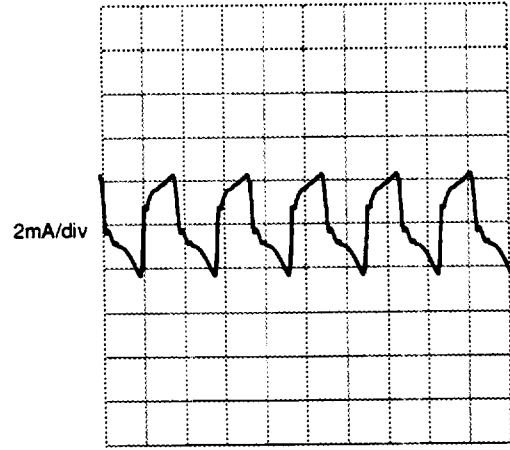


# TYPICAL CHARACTERISTICS

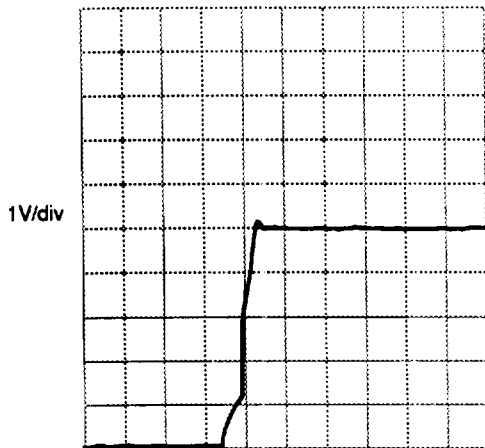
Waveforms shown are for ATW2805



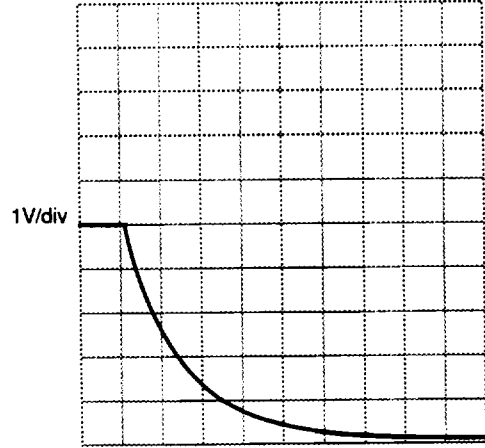
**Figure 1 Output Ripple Voltage**  
 $V_{IN} = 28 \text{ VDC}$ , Full Load



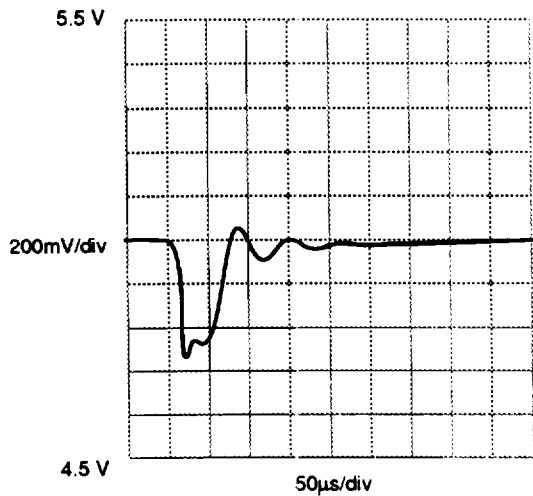
**Figure 2 Input Ripple Voltage**  
 $V_{IN} = 28 \text{ VDC}$ , Full Load



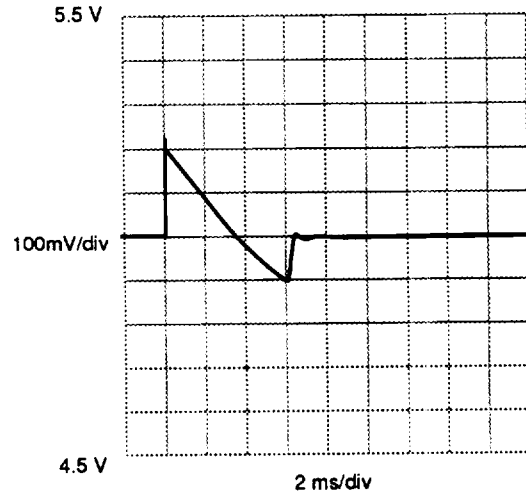
**Figure 3 Turn-on Response @ Full Load**



**Figure 4 Turn-off Response @ Full Load**

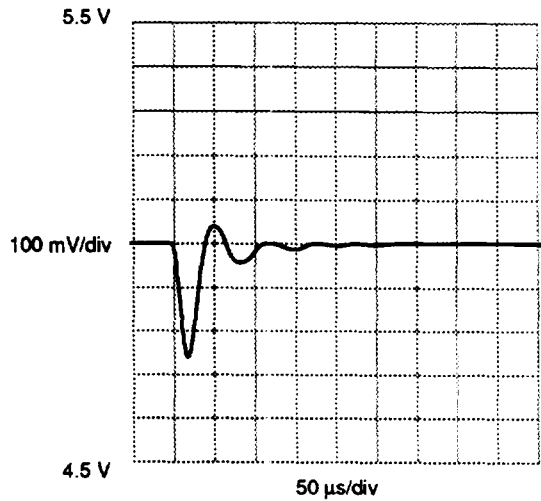


**Figure 5 Load Step Response**  
 Load Step 0 to 3.0 A DC  
 (No Load to Half Load)

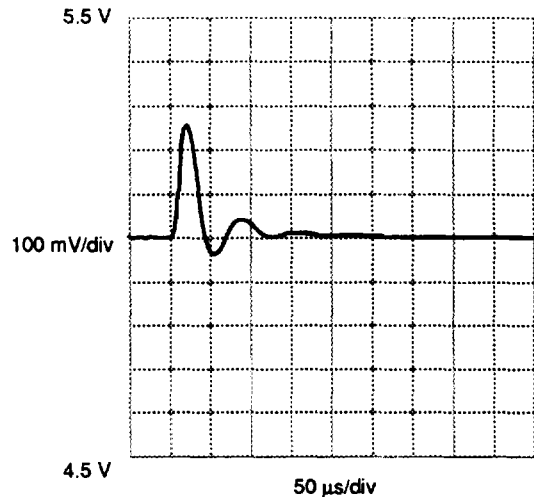


**Figure 6 Load Step Response**  
 Load Step 3.0 to 0 A DC  
 (Half Load to No Load)

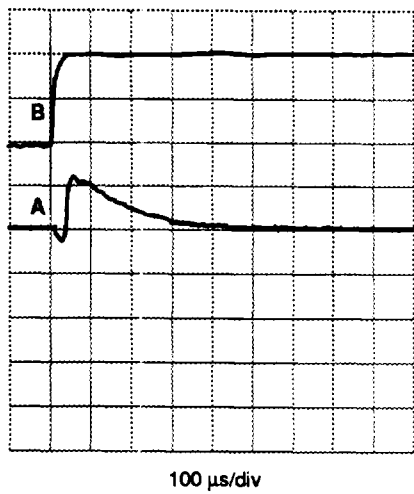
**TYPICAL CHARACTERISTICS (Continued)**



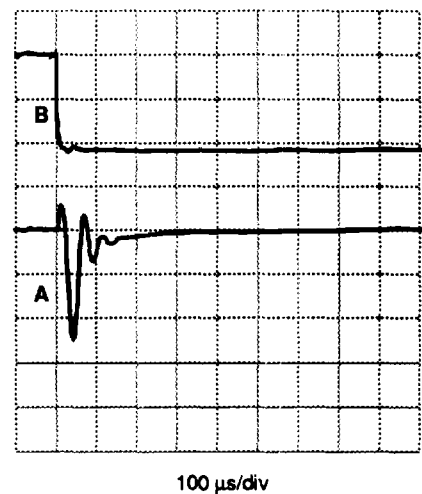
**Figure 7 Load Step Response**  
Load Step 3.0 ADC to 6.0 ADC  
(Half Load to Full Load)



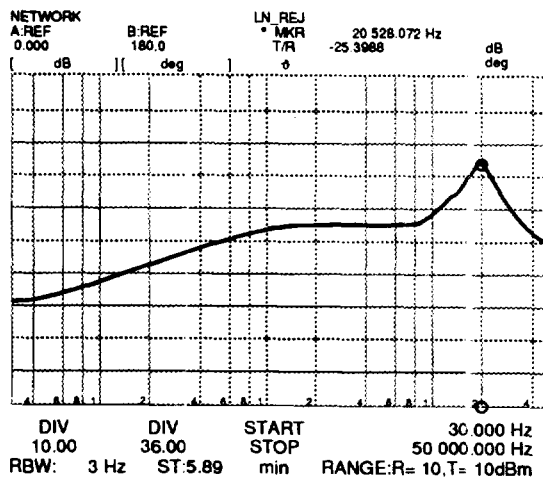
**Figure 8 Load Step Response**  
Load Step 6.0 ADC to 3.0 ADC  
(Full Load to Half Load)



**Figure 9 Line Step Response**  
A: Output @ 50mV V/div, Full Load  
B: Input step @ 19 Vdc to 40 Vdc



**Figure 10 Line Step Response**  
A: Output @ 100mV/div, Full Load  
B: Input Step 40 Vdc to 19 Vdc



**Figure 11 Audio Rejection**

# TYPICAL CHARACTERISTICS (Continued)

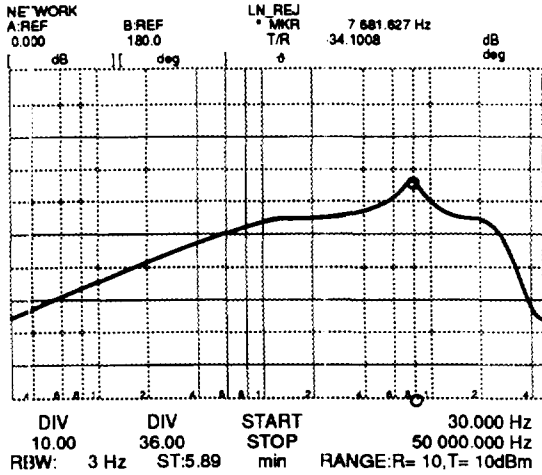
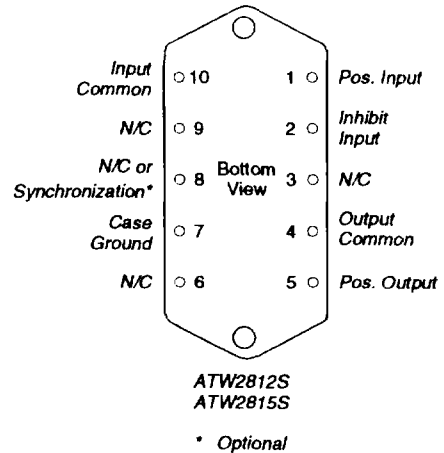
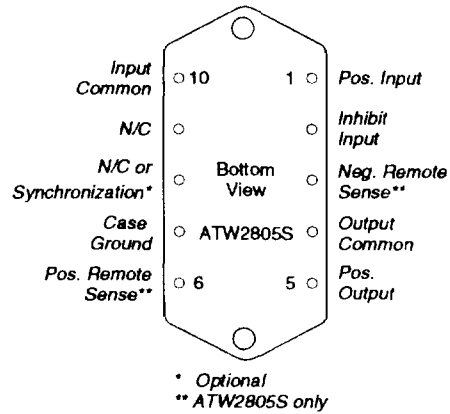
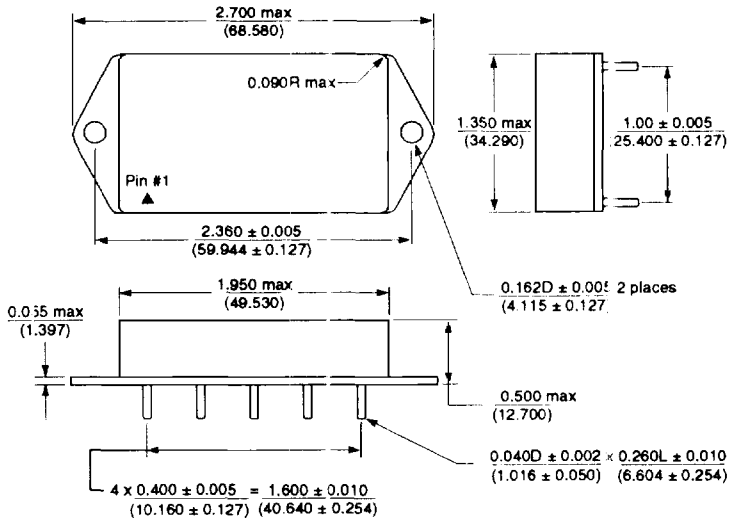


Figure 12 Audio Rejection with AFC481 EMI Filter

## MECHANICAL OUTLINE



## APPLICATION INFORMATION

### Inhibit Function

Connecting the inhibit input (Pin 2) to input common (Pin 10) will cause the converter to shut down. It is recommended that the inhibit pin be driven by an open collector device capable of sinking at least 400  $\mu$ A of current. The open circuit voltage of the inhibit input is  $11.5 \pm 1$  VDC.

### EMI Filter

An optional EMI filter (AFC461) will reduce the input ripple current to levels below the limits imposed by MIL-STD-461B CEO3.

### Remote Sense (ATW2805S only)

Better than 0.1% line and load regulation (case temperature constant) are typical when the remote sense leads are used. If the remote sense leads are left unconnected, then the output voltage (measured at pins 4 and 5) will rise approximately 5.4 VDC.

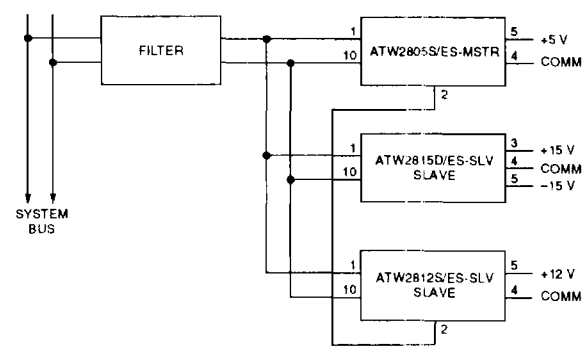
If the remote sense leads are shorted together, the output voltage may rise above 10 VDC depending on load, possibly damaging both the converter and load.

### Device Synchronization

Whenever multiple DC/DC converters are utilized in a single system, significant low frequency noise may be generated due to slight differences in the switching frequencies of the converters (beat frequency noise). Because of the low frequency nature of this noise (typically less than 10 kHz), it is difficult to filter out and may interfere with proper operation of sensitive systems (communications, radar or telemetry). Advanced Analog offers an option which provides synchronization of multiple AHE/ATW type converters, thus eliminating this type of noise.

To take advantage of this capability, the system designer must assign one of the converters as the master. Then, by definition, the remaining converters become slaves and will operate at the masters' switching frequency. The user should be aware that the synchronization system is fail-safe; that is, the slaves will continue operating should the master frequency be interrupted for any reason. The layout must be such that the synchronization output (pin 8) of the master device is connected to the synchronization input (pin 8) of each slave device. It is advisable to keep this run short to minimize the possibility of radiating the 250 kHz switching frequency.

The appropriate parts must be ordered to utilize this feature. After selecting the converters required for the system, a 'MSTR' suffix is added for the master converter part number and a 'SLV' suffix is added for slave part number. See Part Number section.



Typical Synchronization Connection Diagram

## STANDARDIZED MILITARY DRAWING CROSS REFERENCE

Standardized military drawing PIN	Vendor CAGE number	Vendor similar PIN
5962-9157901HZX	52467	ATW2805S/CH
5962-9157902HZX	52467	ATW2805S/CH-SLV
5962-9157903HZX	52467	ATW2805S/CH-MSTR
5962-921101HZX	52467	ATW2812S/CH
5962-921102HZX	52467	ATW2812S/CH-SLV
5962-921103HZX	52467	ATW2812S/CH-MSTR
5962-9159901HZX	52467	ATW2815S/CH
5962-9159902HZX	52467	ATW2815S/CH-SLV
5962-9159903HZX	52467	ATW2815S/CH-MSTR

ATW2805S EFFICIENCY

