

- Series 507 SMT Headers “float” in a machined epoxy insulator.
- Series 513 Interstitial PGA surface mount sockets are available with and without tabs for clip-on heatsinks.
- Mill-Max #43, “Ultra-Lite” contact standard, see page 209 for details.
- Hi-Temp PCT polyester insulator material suitable for all forms of soldering.

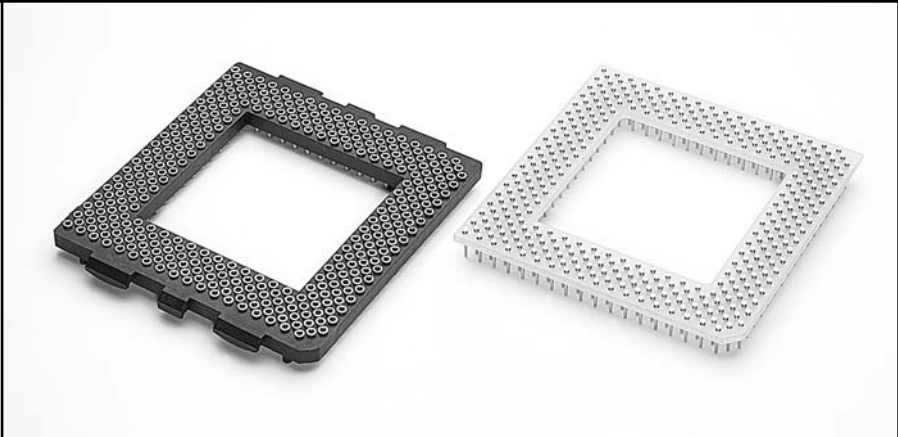

Ordering Information

**HEADER PIN
TYPE 0737**

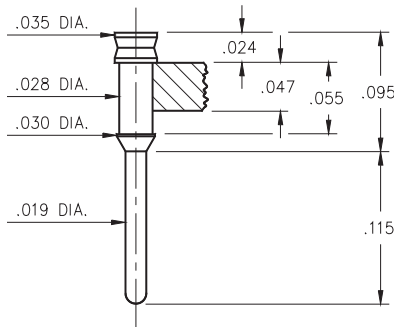

FOR PGA MALE HEADER

1. Locate footprint pattern from pages 107 to 111, the middle 8 digits of the part number will be located under the pattern.

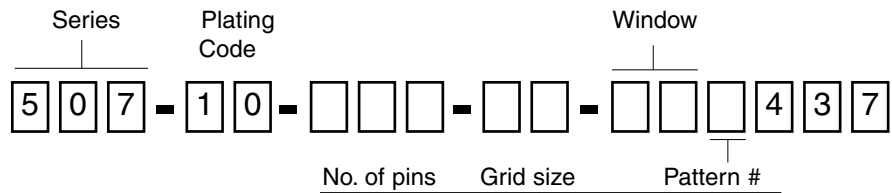

Determined from footprint pattern pages 107 to 111

SPECIFY PLATING CODE XX=	10◇			
Pin Plating	10μ" Au			

**SMT RECEPTACLE
TYPE 1385**

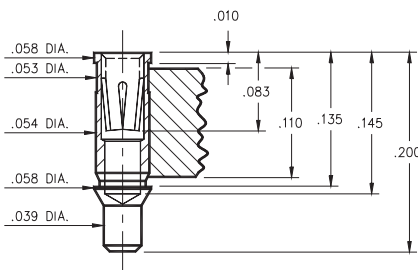

FOR PGA FEMALE SOCKET

1. Specify 2-digit plating code from chart at bottom of page.
2. Locate footprint pattern from pages 107 to 111, the middle 8 digits of the part number will be located under the pattern.

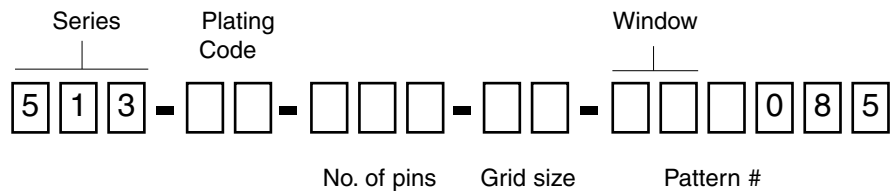

Determined from footprint pattern pages 107 to 111

SPECIFY PLATING CODE XX=	13◇	93	43◇
Sleeve (Pin)	10μ" Au	200μ" Sn/Pb	200μ" Sn
Contact (Clip)	30μ" Au	30μ" Au	30μ" Au