

# TPIC2801A OCTAL INTELLIGENT-POWER SWITCH WITH SERIAL INPUT

SLIS001 - D4054, MAY 1993

- 8-Bit Serial-In Parallel-Out Driver
- 1-A Output Current Capability Per Channel or 8-A Total Current
- Overcurrent Limiting and Out-of-Saturation Voltage Protection on Driver Outputs
- Contains Eight Open-Collector Saturating Sink Outputs With Low On-State Voltage
- High-Impedance Inputs With Hysteresis Are Compatible With TTL or CMOS Levels
- Very Low Standby Power  
20 mW Typical
- Status of Output Drivers May Be Monitored at Serial Output
- 3-State Serial Output Permits Serial Cascading or Wire-AND Device Connections
- 35-V Transient Clamping With Inductive Switching on Outputs, 40-mJ Rating Per Driver Output

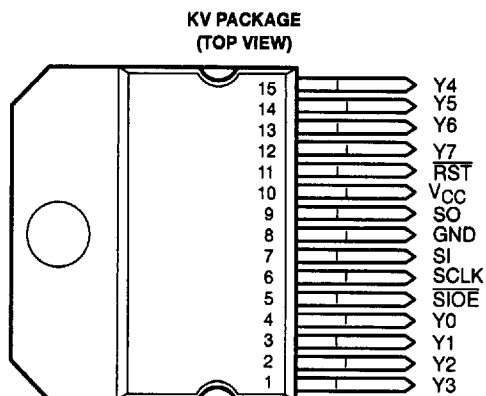

## description

The TPIC2801A octal intelligent-power switch is a monolithic BIFDET<sup>†</sup> integrated circuit designed to sink currents up to 1 A at 35 V simultaneously at each of eight driver outputs under serial input data control. Status of the individual driver outputs is available in serial data format. The driver outputs have overcurrent limiting and out-of-saturation voltage protection features. Applications include driving solenoids, relays, dc motors, lamps, and other medium-current or high-voltage loads.

The device contains an 8-bit serial-in, parallel-out shift register that feeds an 8-bit parallel latch, which independently controls each of the eight Y-output drivers.

Data is entered into the device serially via the serial input (SI) and goes directly into the lowest bit (0) of the shift register. Using proper timing signals, the input data is passed to the corresponding output latch and output driver. A logic-high SI bit n turns the corresponding output driver (Y<sub>n</sub>) off. A logic-low bit at SI turns the corresponding output driver on. Serial data is transferred into SI on the high-to-low transition of the serial clock (SCLK) input in 8-bit bytes with data for the Y7 output (most significant bit) first and data for Y0 output (least significant bit) last. Both SI and SCLK are active when the serial input-output enable ( $\overline{\text{SIOE}}$ ) input is low and are disabled when  $\overline{\text{SIOE}}$  is high.

Each driver output is monitored by a voltage comparator that compares the Y-output voltage level with an internal out-of-saturation threshold voltage reference level. The logic state of the comparator output is dependent upon whether the Y output is greater or smaller than the reference voltage level. While  $\overline{\text{SIOE}}$  is held high, an activated driver output is unlatched and turned off when the output voltage exceeds the out-of-saturation threshold voltage level except when the internal unlatch enable is low and disabled. The high-to-low transition of  $\overline{\text{SIOE}}$  transfers the logic state of the comparator output to the shift register.

<sup>†</sup>BIFDET - Bipolar double-diffused, N-channel and P-channel MOS transistors are on the same chip. This is a patented process.

PRODUCTION DATA information is current as of publication date.  
Products conform to specifications per the terms of Texas Instruments  
standard warranty. Production processing does not necessarily include  
testing of all parameters.

Copyright © 1993, Texas Instruments Incorporated

**TEXAS  
INSTRUMENTS**

POST OFFICE BOX 655303 • DALLAS, TEXAS 75265

2-75

8961724 0092148 592

**TPIC2801A**  
**OCTAL INTELLIGENT-POWER SWITCH**  
**WITH SERIAL INPUT**

SLIS001 - D4054, MAY 1993

**functional block diagram**

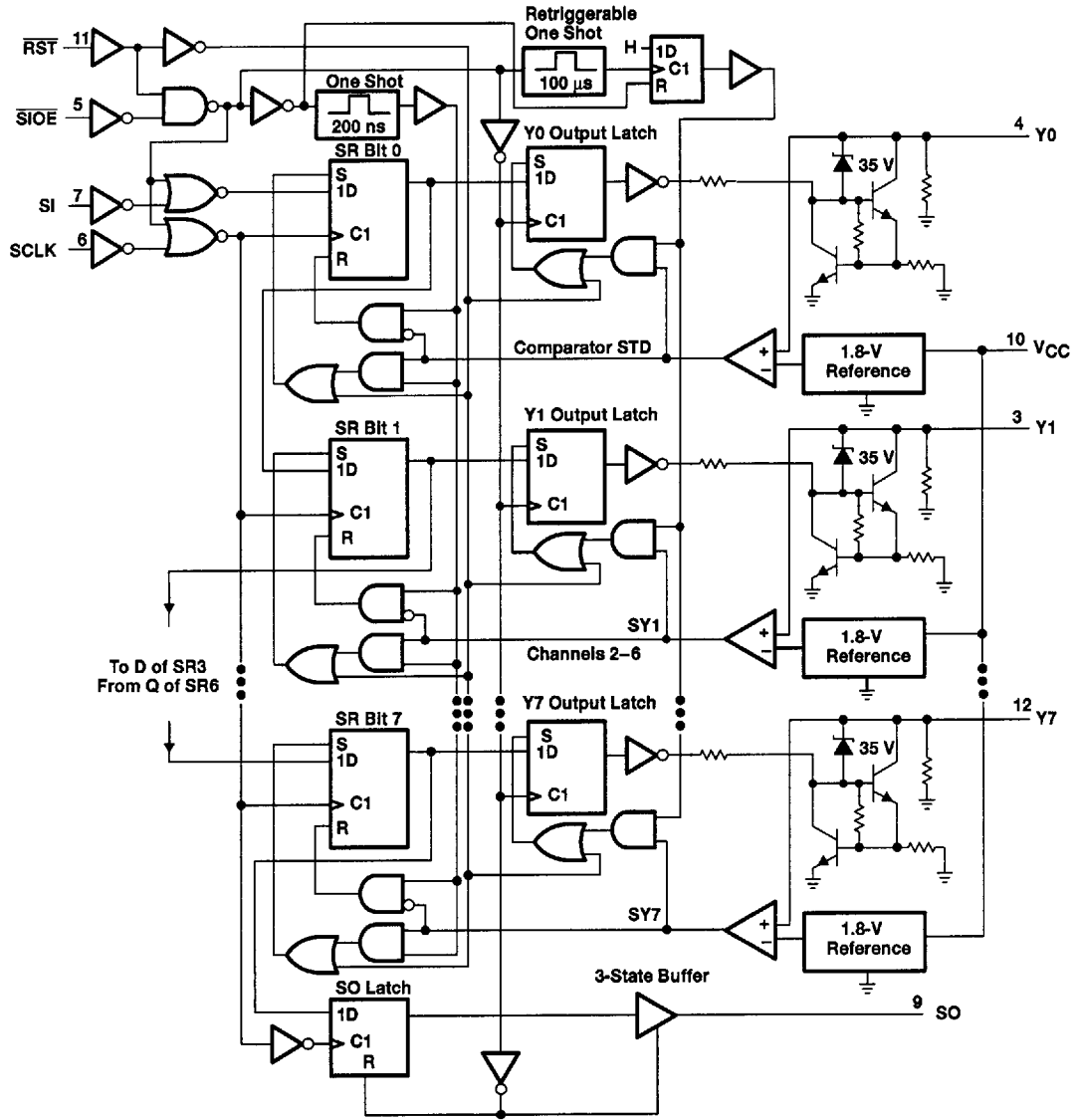

**TPIC2801A**  
**OCTAL INTELLIGENT-POWER SWITCH**  
**WITH SERIAL INPUT**  
 SLIS001 – D4054, MAY 1993

**Terminal Functions**

PIN NAME NO.	I/O	DESCRIPTION
GND 8		Ground. Common return for entire chip. The output current from this terminal is potentially as high as 8 A if all outputs are on. GND is used for both logic and power circuits.
RST 11	I	Reset. An asynchronous reset is provided for the shift register and the parallel latches. This terminal is active when low and has no internal pullup. When active, it causes the power outputs to turn off. A power-on clear can be implemented using an RC network to VCC.
SCLK 6	I	Serial clock. This terminal clocks the shift register. The serial output (SO) changes state on the rising edge of SCLK, and serial input (SI) data is accepted on the falling edge.
SI 7	I	Serial Input. A high on this terminal programs a particular output to be off, and a low turns it on.
SIOE 5	I	Serial Input-output enable. Data is transferred from the shift registers to the power outputs on the rising edge of this signal. The falling edge of this signal parallel loads the output voltage sense bits from the power output stages into the shift register. The output driver SO is enabled when this terminal is low, provided RST is high.
SO 9	O	Serial output. This terminal is the serial 3-state output from the shift register and is in a high-impedance state when SIOE is high or RST is low. A high for a data bit on this terminal indicates that the corresponding power output (Y <sub>n</sub> ) is high. This means that the output was programmed to be off the last time a byte was input to the device or that the output faulted and was latched off by the output voltage-sense indicator. A low on this output indicates that the corresponding power output (Y <sub>n</sub> ) is low (on output stage or open-circuit condition).
VCC 10		5-V supply voltage
Y0 4 Y1 3 Y2 2 Y3 1 Y4 15 Y5 14 Y6 13 Y7 12	O	Power outputs. These outputs are provided with current limiting and voltage sense for fault indication and protection. The nominal load current for these outputs is 500 mA, and the current limiting is set to a minimum of 1.05 A. The active-low outputs also have voltage clamps set at about 35 V for recirculation of inductive load current. Internal 90-kΩ pull-down resistors are provided at each output. These resistors hold the output low during an open-circuit condition.

**schematic of inputs and outputs**

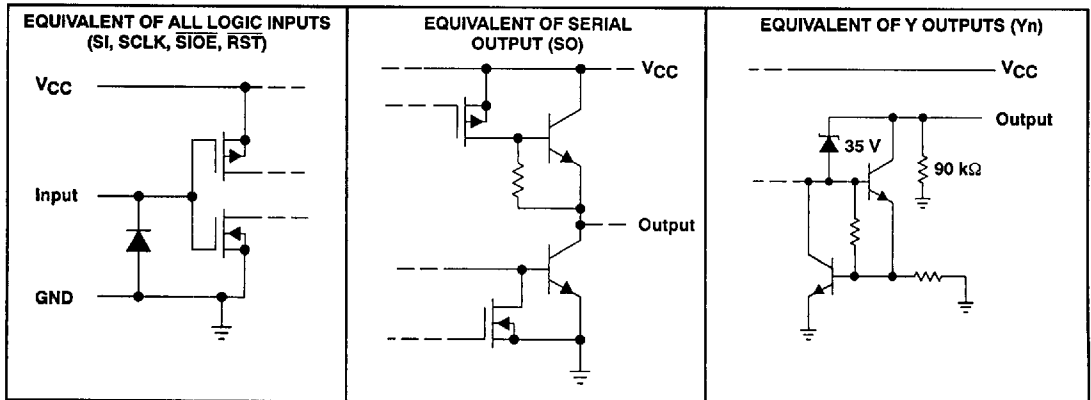

All resistor and voltage values shown are nominal.

**TPIC2801A**  
**OCTAL INTELLIGENT-POWER SWITCH**  
**WITH SERIAL INPUT**

SLIS001 – D4054, MAY 1993

**absolute maximum ratings over operating temperature range (unless otherwise noted)**

Supply voltage range, $V_{CC}$ (see Note 1)	– 0.3 V to 7 V
Input voltage, $V_I$	7 V
Output voltage range at $SO$ , $V_O$	– 0.3 V to 7 V
Input current, $I_I$	– 15 mA
Peak output sink current at $Y$ , $I_O$ repetitive, $t_w = 10$ ms, duty cycle = 50%, (see Notes 2 and 3)	internally limited
Continuous output current at $Y$ , $I_O$ (see Note 3)	1 A
Peak current through GND: Nonrepetitive $t_w = 0.2$ ms	– 8 A
Repetitive $t_w = 10$ ms, duty cycle = 50%	– 6 A
Output clamp energy, $E_{OK}$ (after turning off $I_O(\text{on}) = 0.5$ A)	40 mJ
Continuous current through GND	– 4.5 A
Continuous dissipation at (or below) $T_A = 25^\circ\text{C}$ (see Note 4)	3.575 W
Continuous dissipation at (or below) $T_C = 75^\circ\text{C}$ (see Note 4)	25 W
Operating case or virtual junction temperature range	– 55°C to 150°C
Storage temperature range	– 65°C to 150°C
Lead temperature 1, 6 mm (1/16 inch) from case for 10 seconds	260°C

- NOTES: 1. All voltage values are with respect to network GND.  
2. Each Y output is individually current limited with a typical overcurrent limit of about 1.4 A.  
3. Multiple Y outputs of this device can conduct rated current simultaneously; however, power dissipation (average) over a short time interval must fall within the continuous dissipation range and GND current range.  
4. For operation above 25°C free-air temperature, derate linearly at the rate of 28.6 mW/°C. For operation above 75°C case temperature, derate linearly at the rate of 333 mW/°C. To avoid exceeding the maximum virtual junction temperature, these ratings must not be exceeded.

**recommended operating conditions**

	MIN	NOM	MAX	UNIT
Supply voltage, $V_{CC}$	4.75	5	5.25	V
High-level input voltage, $V_{IH}$	0.75 $V_{CC}$		5.25	V
Low-level input voltage, $V_{IL}$	– 0.3		0.2 $V_{CC}$	V
Output voltage, $V_{O(\text{off})}$			30	V
Continuous output current, $I_{O(\text{on})}$			1	A
Operating case temperature, $T_C$	– 40	25	105	°C

**electrical characteristics over recommended ranges of supply voltage and operating case temperature (unless otherwise noted)**

PARAMETER		TEST CONDITIONS		MIN	TYP	MAX	UNIT
$I_{CC}$	Supply current	All outputs on, $I_O = 0.5$ A at all outputs	$T_J = 105^\circ\text{C}$			150	mA
			$T_J = 25^\circ\text{C}$			200	
			$T_J = -40^\circ\text{C}$			250	
		All outputs off	$T_J = 25^\circ\text{C}$	4	10		



POST OFFICE BOX 655303 • DALLAS, TEXAS 75285

**TPIC2801A**  
**OCTAL INTELLIGENT-POWER SWITCH**  
**WITH SERIAL INPUT**

SLIS001 – D4054, MAY 1993

electrical characteristics over recommended ranges of supply voltage and operating case temperature (unless otherwise noted) (continued)

**driver array outputs (Y0 to Y7)**

PARAMETER	TEST CONDITIONS	MIN	TYP†	MAX	UNIT
V <sub>O(k)</sub> Output clamp voltage	I <sub>O</sub> = 0.5 A, Output programmed off and current shunted to GND	30	36	40	V
V <sub>O(on)</sub> On-state output voltage	With one output programmed on and conducting	I <sub>OL</sub> = 0.5 A	0.4	0.5	V
		I <sub>OL</sub> = 0.75 A	0.6	1	V
		I <sub>OL</sub> = 1 A, During unlatch disable	0.8	1.5	V
V <sub>TOS</sub> Out-of-saturation threshold voltage	With output programmed on and an overcurrent fault condition	1.6	1.8	2.1	V
I <sub>O(off)</sub> Off-state output current	V <sub>O</sub> = 24 V with output programmed off			1	mA
I <sub>O(c)</sub> Output current limit	V <sub>O</sub> = 3 V with output programmed on	1.05	1.4		A

**shift register (Inputs SI, SIOE, SCLK, and RST)**

PARAMETER	TEST CONDITIONS	MIN	MAX	UNIT
V <sub>T+</sub> Positive-going threshold voltage			0.75 V <sub>CC</sub>	V
V <sub>T-</sub> Negative-going threshold voltage		0.2 V <sub>CC</sub>		V
V <sub>hys</sub> Hysteresis voltage (V <sub>T+</sub> - V <sub>T-</sub> )		0.85	2.25	V
I <sub>I</sub> Input current	V <sub>I</sub> = 0 to V <sub>CC</sub>		±10	µA
C <sub>i</sub> Input capacitance	V <sub>I</sub> = 0 to V <sub>CC</sub>		20	pF

**shift register (output SO)**

PARAMETER	TEST CONDITIONS	MIN	TYP†	MAX	UNIT
V <sub>OL</sub> Low-level output voltage	I <sub>O</sub> = 1.6 mA		0.2	0.4	V
V <sub>OH</sub> High-level output voltage	I <sub>O</sub> = -0.8 mA	V <sub>CC</sub> - 1.3			V
I <sub>O</sub> Output current	V <sub>O</sub> = 0 to V <sub>CC</sub> , SIOE input high			±20	µA
C <sub>O</sub> Output capacitance	V <sub>O</sub> = 0 to V <sub>CC</sub> , SIOE input high			20	pF

† All typical values are at V<sub>CC</sub> = 5 V, T<sub>J</sub> = 25°C.

**timing requirements over recommended ranges of supply voltage and operating case temperature (see Figure 1)**

		MIN	MAX	UNIT
f <sub>clock</sub> Clock frequency, SCLK	See Note 5	0	1	MHz
t <sub>w(SCLKH)</sub> Pulse duration, SCLK high		410		ns
t <sub>w(SCLKL)</sub> Pulse duration, SCLK low		410		ns
t <sub>w(RST)</sub> Pulse duration, RST low		1000		ns
t <sub>su1</sub> Setup time, SIOE↓ before SCLK↑		1		µs
t <sub>su2</sub> Setup time, SCLK↓ before SIOE↑		1		µs
t <sub>su3</sub> Setup time, SI high before SCLK↓		150		ns
t <sub>h1</sub> Hold time, SI low after SCLK↓		150		ns
t <sub>r</sub> Rise time, SCLK, SI, SIOE			90	ns
t <sub>f</sub> Fall time, SCLK, SI, SIOE			90	ns

NOTE 5: For cascaded operation, the clock pulse durations [t<sub>w</sub>(SCLKL) and t<sub>w</sub>(SCLKH)] must be a minimum of 700 ns (giving a maximum clock frequency of 632 kHz).



**TPIC2801A**  
**OCTAL INTELLIGENT-POWER SWITCH**  
**WITH SERIAL INPUT**

SLIS001 – D4054, MAY 1993

**thermal characteristics**

PARAMETER		MIN	MAX	UNIT
$R_{\theta JC}$	Thermal resistance, junction-to-case temperature		3	°C/W
$R_{\theta JA}$	Thermal resistance, junction-to-ambient temperature		35	°C/W

**switching characteristics over recommended ranges of supply voltage and operating case temperature**

PARAMETER		FROM (INPUT)	TO (OUTPUT)	TEST CONDITIONS	MIN	MAX	UNIT
$t_{en}$	Enable time	$\overline{SIOE}\downarrow$	SO	$C_L = 20$ pF, $R_L = 1$ k $\Omega$ , See Figure 2		1000	ns
$t_{dis}$	Disable time	$\overline{SIOE}\uparrow$	SO	$C_L = 20$ pF, $R_L = 1$ k $\Omega$ , See Figure 2		1000	ns
$t_{d1}$	Delay time, valid data	SCLK $\uparrow$	SO	$C_L = 200$ pF, See Figure 3		550	ns
$t_{d2}$	Delay time, unlatch disable	$\overline{SIOE}\uparrow$	$Y_n$	$C_L = 20$ pF, $R_L = 5$ $\Omega$ , See Figure 4	75	250	$\mu$ s
$t_r(SO)$	Rise time		SO	$C_L = 200$ pF, See Figure 3		150	ns
$t_f(SO)$	Fall time		SO	$C_L = 200$ pF, See Figure 3		150	ns
$t_{d(on)}$	Delay time, turn on	$\overline{SIOE}\uparrow$	$Y_n$	$C_L = 20$ pF, $R_L = 28$ $\Omega$ , $I_{OL} = 500$ mA, See Figure 5		10	$\mu$ s
$t_{d(off)}$	Delay time, turn off	$\overline{SIOE}\uparrow$	$Y_n$	$C_L = 20$ pF, $R_L = 28$ $\Omega$ , $I_{OL} = 500$ mA, See Figure 5		10	$\mu$ s
$t_v$	Valid time, SO output data remains valid after SCLK high	SCLK $\uparrow$	SO	$C_L = 200$ pF, See Figure 3	0		ns



**PARAMETER MEASUREMENT INFORMATION**

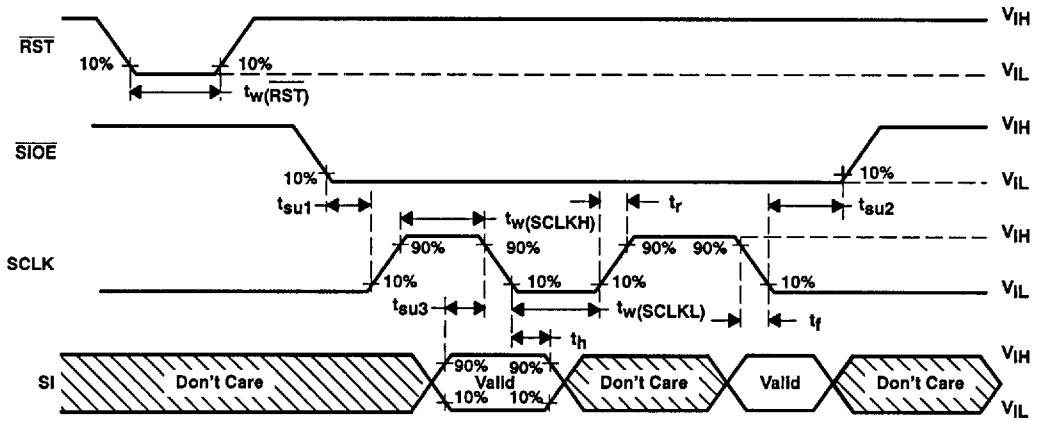
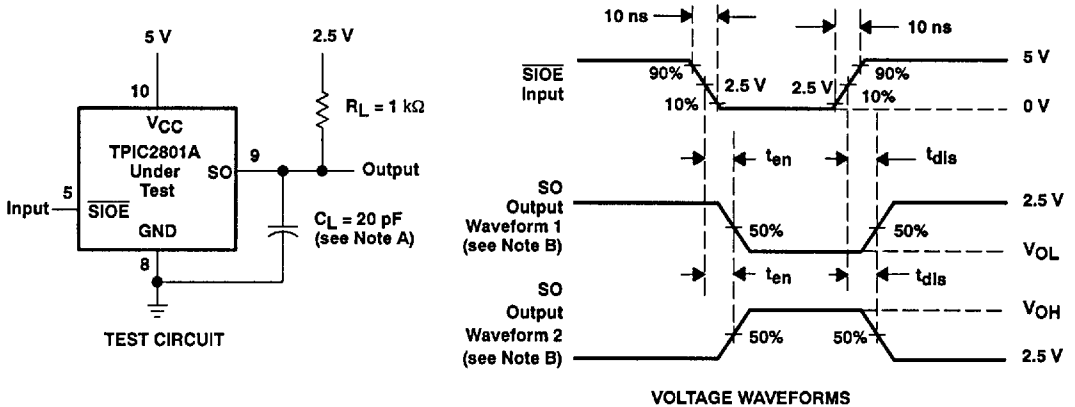

Figure 1. Input Timing Diagram



- NOTES: A.  $C_L$  includes probe and jig capacitance.  
 B. Waveform 1 is for an output with internal conditions such that the output is low except when disabled by the output control when  $\overline{SIOE}$  is high. Waveform 2 is for an output with internal conditions such that the low-to-high transition of  $\overline{SIOE}$  causes the output to switch from off to on.

Figure 2. Enable and Disable Times Test Circuit and Voltage Waveforms

**TPIC2801A**  
**OCTAL INTELLIGENT-POWER SWITCH**  
**WITH SERIAL INPUT**  
 SLJS001 – D4054, MAY 1993

**PARAMETER MEASUREMENT INFORMATION**

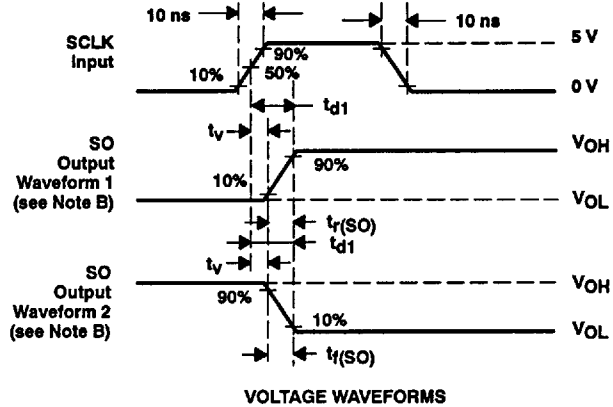
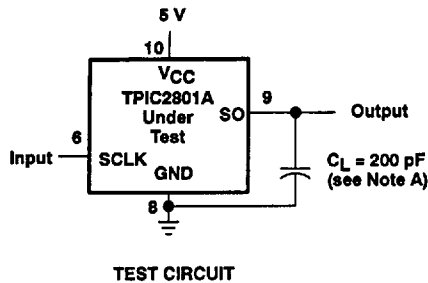

- NOTES: A.  $C_L$  includes probe and jig capacitance.  
 B. Waveform 1 is for an output with internal conditions such that the low-to-high transition of SCLK causes the SO output to switch from high to low. Waveform 2 is for an output with internal conditions such that the low-to-high transition of SIOE causes the output to switch from off to on.

**Figure 3. Delay Times Test Circuit and Voltage Waveforms**

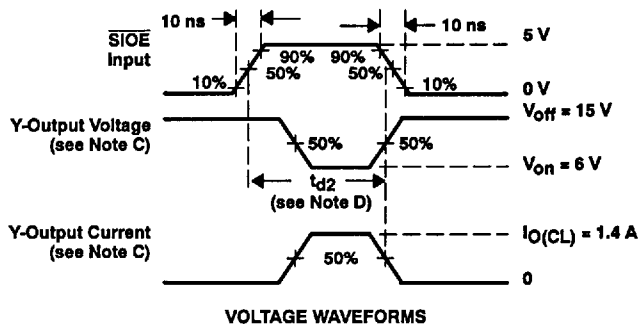
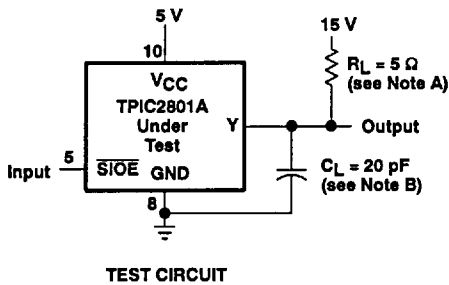

- NOTES: A. Load voltage  $V_S$  and load resistance  $R_L$  are selected such that on-state voltage at the Y output under test,  $V_{ON}$  is greater than the maximum out-of-saturation hold voltage,  $V_{TOS}$ . Thus  $V_{OL} = V_{ON} > V_{TOS(max)} = 2.1$  V.  
 B.  $C_L$  includes probe and jig capacitance.  
 C. Output voltage and current waveforms are for an output with internal conditions such that the low-to-high transition of SIOE causes the output to switch from off to on.  
 D.  $t_{d2}$  = delay until Y-output current goes off under fault condition.

**Figure 4. Unlatch Disable Delay Test Circuit and Voltage Waveforms**

**PARAMETER MEASUREMENT INFORMATION**

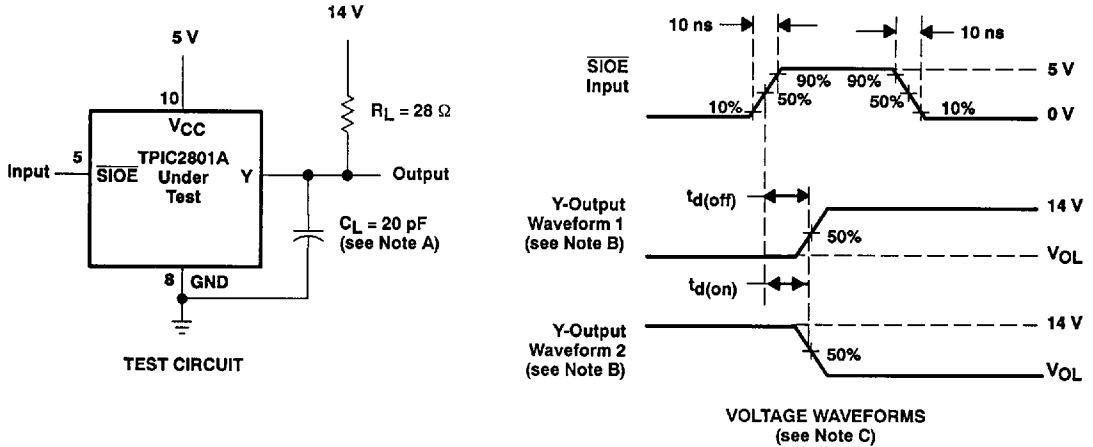

- NOTES: A.  $C_L$  includes probe and jig capacitance.  
 B. Waveform 1 is for an output with internal conditions such that the low-to-high transition of  $\overline{\text{SIOE}}$  causes the output to switch from on to off. Waveform 2 is for an output with internal conditions such that the low-to-high transition of  $\overline{\text{SIOE}}$  causes the output to switch from off to on.  
 C.  $t_{d(\text{off})} = t_{\text{PLH}}$ ,  $t_{d(\text{on})} = t_{\text{PHL}}$

**Figure 5. Turn-Off and Turn-On Delay Times Test Circuit and Voltage Waveforms**

**APPLICATION INFORMATION**

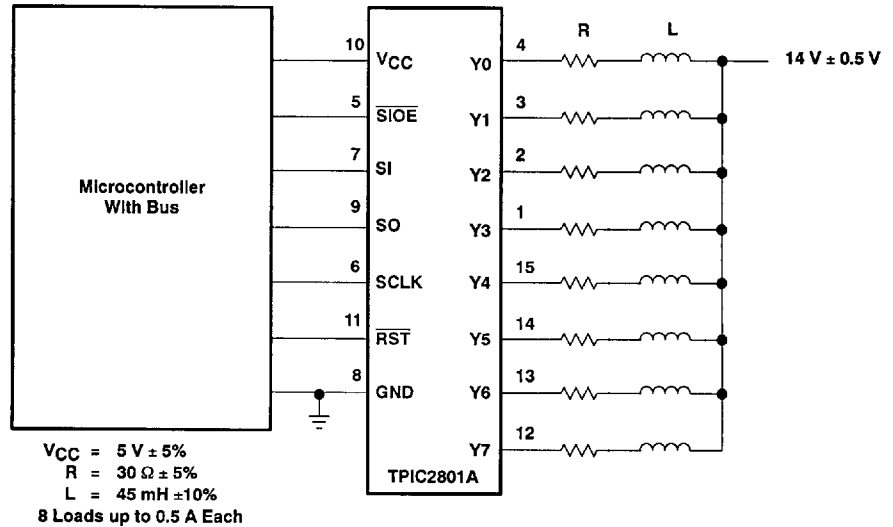

**Figure 6. Microcontroller Driving Eight Loads Using a TPIC2801A for Load Interface**

**TPIC2801A**  
**OCTAL INTELLIGENT-POWER SWITCH**  
**WITH SERIAL INPUT**

SLIS001 - D4054, MAY 1993

**PRINCIPLES OF OPERATION**

**timing data transfer**

Figure 7 shows the overall 8-bit data-byte transfer to and from the TPIC2801A interface bus. The logic state of the eight output drivers, Y0 through Y7, is latched into the shift register at time  $t_0$  on the high-to-low transition of  $\overline{\text{SIOE}}$ . Therefore, the SO output data (DY0, DY1 . . . ) represents the conditions at the Y-driver outputs at time  $t_0$ . The data at the SO output is updated on the low-to-high transition of SCLK.

Input data present at the SI input is clocked into the shift register on the high-to-low transition of SCLK. As shown in Figure 7 on the SI input, input data DI7 is clocked at time  $t_1$ , DI6 is clocked at time  $t_2$ , etc. Eight SCLK pulses are used to serially load the eight bits of new data into the device. After all the new data is serially loaded, the low-to-high transition of  $\overline{\text{SIOE}}$  parallel loads the new data to the eight driver output latches, which in turn directly control the eight Y-driver outputs.

An unlimited amount of data can be shifted through the shift register (into the SI and out the SO), and this allows other devices to be cascaded in a daisy chain with the TPIC2801A. Once the last data bit is shifted into the TPIC2801A, the  $\overline{\text{SIOE}}$  input is pulled high. The clock (SCLK) input is low at both transitions of the  $\overline{\text{SIOE}}$  input to avoid any false clocking of the shift register. The SCLK input is gated by the  $\overline{\text{SIOE}}$  input, so the SCLK input is ignored whenever  $\overline{\text{SIOE}}$  is high. At the rising edge of  $\overline{\text{SIOE}}$ , the shift register data is latched into the parallel latch and the output stages are actuated by the new data. An internal 100- $\mu\text{s}$  delay timer is also started on this rising edge. During the time delay, the outputs are protected only by the analog current-limiting circuits, since the resetting of the parallel latches by fault conditions is inhibited during this time period. This allows the device to overcome any high switching currents that can flow during turn on. Once the delay ends, the output voltages are sensed by the comparators and any output voltages higher than nominally 1.8 V are latched off.

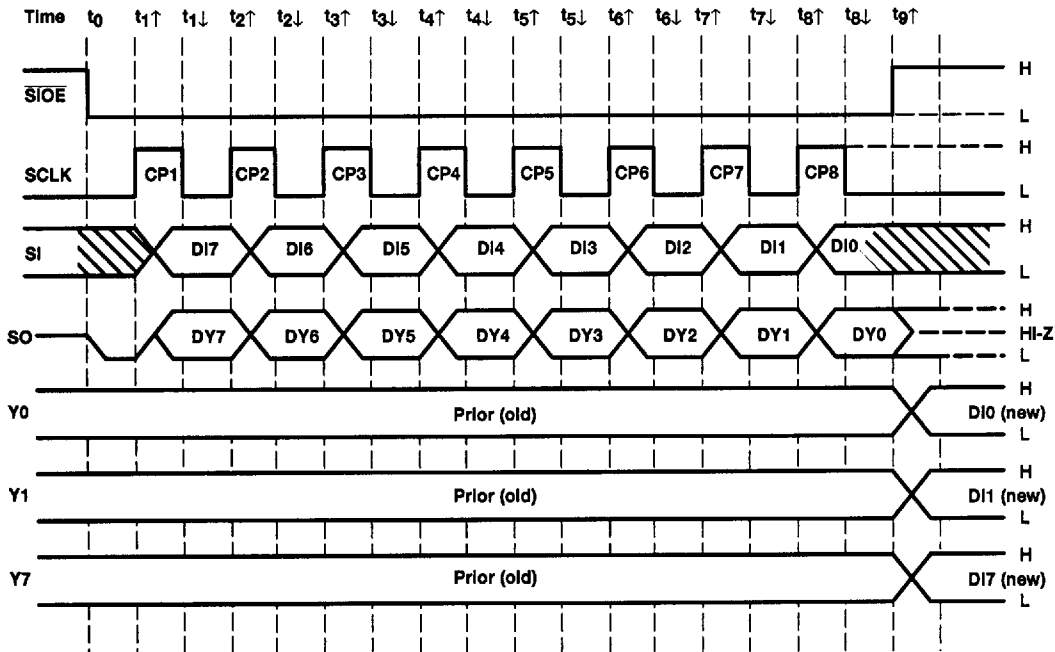

**Figure 7. Data-Byte Transfer Timing**



POST OFFICE BOX 655303 • DALLAS, TEXAS 75265

**fault-conditions check**

Open-circuit conditions on any output can be monitored or checked by programming that output off. After a short delay (microseconds), another control byte can be clocked into the device. If the diagnostic bit for that output comes back low, it indicates that the output is low and open circuited. A current overload condition is detected by programming an output on. After waiting an appropriate length of time, another byte is clocked into the TPIC2801A. The diagnostic bit clocked back from the TPIC2801A in the subsequent data transfer indicates a low output. If a high returns, a current overload is indicated. A quick overall check is done by clocking in a test control byte and after a sufficient time delay, clock in another control byte. The diagnostic data is exclusive ORed with the original control byte. If a fault condition exists, a high results from the subsequent exclusive OR.