



±15kV ESD-Protected USB Transceivers

MAX3453E-MAX3456E

General Description

The MAX3453E–MAX3456E ±15kV ESD-protected USB-compliant transceivers interface low-voltage ASICs with USB devices. The devices fully comply with USB 1.1 and USB 2.0 when operating at full (12Mbps) and low (1.5Mbps) speeds. The MAX3453E–MAX3456E operate with V_L as low as +1.65V, ensuring compatibility with low-voltage ASICs.

The MAX3453E–MAX3456E feature a logic-selectable suspend mode that reduces current consumption to less than 40 μ A. Integrated ±15kV ESD protection protects the USB D+ and D- bidirectional bus connections.

The MAX3453E supports only full-speed (12Mbps) operation. The MAX3453E/MAX3454E feature an internal 1.5k Ω USB pullup resistor and an enumeration function that allows devices to logically disconnect while plugged in. The MAX3453E/MAX3455E provide a push-pull bus-detect (BD) output that asserts high when $V_{BUS} > +4.0V$.

The MAX3453E–MAX3456E operate over the extended temperature range (-40°C to +85°C) and are available in 14-pin TSSOP and 16-pin (3mm x 3mm) thin QFN packages.

Applications

PDA's
PC Peripherals
Cellular Telephones
Data Cradles
MP3 Players

Features

- ◆ ±15kV ESD Protection on D+ and D-
- ◆ USB 1.1 and USB 2.0 (Low-Speed and Full-Speed)-Compliant Transceivers
- ◆ Combined VP and VM Inputs/Outputs
- ◆ +1.65V to +3.6V V_L Logic Supply Input for Interfacing with Low-Voltage ASICs
- ◆ Enumerate Input Function (MAX3453E/MAX3454E)
- ◆ Powered from Li+ Battery as Low as +3.1V (MAX3454E/MAX3456E)
- ◆ VBUS Detection (MAX3453E/MAX3455E)
- ◆ Internal Pullup Resistor (MAX3453E/MAX3454E)
- ◆ No Power-Supply Sequencing Required

Ordering Information

PART	TEMP RANGE	PIN-PKG	PKG CODE
MAX3453EEUD	-40°C to +85°C	14 TSSOP	U14-1
MAX3453EETE	-40°C to +85°C	16 Thin QFN	T1633-4
MAX3454EEUD	-40°C to +85°C	14 TSSOP	U14-1
MAX3454EETE	-40°C to +85°C	16 Thin QFN	T1633-4
MAX3455EEUD	-40°C to +85°C	14 TSSOP	U14-1
MAX3455EETE	-40°C to +85°C	16 Thin QFN	T1633-4
MAX3456EEUD	-40°C to +85°C	14 TSSOP	U14-1
MAX3456EETE	-40°C to +85°C	16 Thin QFN	T1633-4

Selector Guide

PART	V _{BUS} POWER-SUPPLY VOLTAGE (V)	V _L POWER-SUPPLY VOLTAGE (V)	INTERNAL PULLUP RESISTOR	V _{BUS} LEVEL DETECT	ENUMERATE	USB SPEED SUPPORTED	±15kV ESD PROTECTION
MAX3453E	4.0 to 5.5	1.65 to 3.6	Yes	Yes	Yes	Full	Yes
MAX3454E	3.0 to 5.5	1.65 to 3.6	Yes	No	Yes	Low/full	Yes
MAX3455E	4.0 to 5.5	1.65 to 3.6	No	Yes	No	Low/full	Yes
MAX3456E	3.0 to 5.5	1.65 to 3.6	No	No	No	Low/full	Yes

Typical Operating Circuit appears at end of data sheet.

Pin Configurations appear at end of data sheet.



Maxim Integrated Products 1

For pricing, delivery, and ordering information, please contact Maxim/Dallas Direct! at 1-888-629-4642, or visit Maxim's website at www.maxim-ic.com.

±15kV ESD-Protected USB Transceivers

ABSOLUTE MAXIMUM RATINGS

V_{BUS}, V_L, D+, D- to GND.....-0.3V to +6.0V
 V_{TRM} to GND-0.3V to (V_{BUS} + 0.3V)
 VP, VM, SUS, ENUM, SPD,
 RCV, \overline{OE} , BD to GND-0.3V to (V_L + 0.3V)
 Current (into any pin)±15mA
 Short-Circuit Current (D+ and D-).....±150mA

Continuous Power Dissipation (T_A = +70°C)
 14-Pin TSSOP (derate 9.1mW/°C above +70°C)727mW
 16-Pin Thin QFN (derate 14.7mW/°C above +70°C)....1176mW
 Operating Temperature Range-40°C to +85°C
 Junction Temperature+150°C
 Storage Temperature Range-65°C to +150°C
 Lead Temperature (soldering, 10s)+300°C

Stresses beyond those listed under "Absolute Maximum Ratings" may cause permanent damage to the device. These are stress ratings only, and functional operation of the device at these or any other conditions beyond those indicated in the operational sections of the specifications is not implied. Exposure to absolute maximum rating conditions for extended periods may affect device reliability.

DC ELECTRICAL CHARACTERISTICS

(V_{BUS} = +4.0V to +5.5V or V_{TRM} = +3.0V to +3.6V, V_L = +1.65V to +3.6V, T_A = T_{MIN} to T_{MAX}, unless otherwise noted. Typical values are at V_{BUS} = +5.0V, V_L = +2.5V, and T_A = +25°C.) (Note 1)

PARAMETER	SYMBOL	CONDITIONS		MIN	TYP	MAX	UNITS
SUPPLY INPUTS (V_{BUS}, V_{TRM}, V_L)							
Regulated Supply Voltage Output	V _{TRM}	Internal regulator		3.0	3.3	3.6	V
Operating Supply Current	I _{VBUS}	Full-speed transmitting and receiving at 12Mbps, C _L = 50pF on D+ and D- (Note 2)				10	mA
Operating V _L Supply Current	I _{VL}	Full-speed transmitting and receiving at 12Mbps (Note 2)				2.5	mA
Full-Speed Idle and SE0 Supply Current	I _{VBUS(IDLE)}	Full-speed idle: V _{D+} > 2.7V, V _{D-} < 0.3V			250	350	μA
		SE0: V _{D+} < 0.3V, V _{D-} < 0.3V			250	350	
Static V _L Supply Current	I _{VL(STATIC)}	Full-speed idle, SE0, or suspend mode	MAX3453E/MAX3455E			15	μA
			MAX3454E/MAX3456E			5	
Suspend Supply Current	I _{VBUS(SUSP)}	VM = VP = open, SUS = \overline{OE} = high	MAX3453E (ENUM = low), MAX3455E			40	μA
			MAX3454E (ENUM = low), MAX3456E			35	
Disable Mode Supply Current	I _{VBUS(DIS)}	V _L = GND or open				20	μA
Sharing Mode V _L Supply Current	I _{VL(SHARING)}	V _{BUS} = GND or open, \overline{OE} = low, VP = low or high, VM = low or high, SUS = high	MAX3453E/MAX3455E			20	μA
			MAX3454E/MAX3456E			5	
D+/D- Sharing Mode Load Current	I _{D_(SHARING)}	V _{BUS} = GND or open, V _{D-} = 0 or +5.5V				20	μA
D+/D- Disable Mode Load Current	I _{D_(DIS)}	V _L = GND or open, V _{D-} = 0 or +5.5V				5	μA

±15kV ESD-Protected USB Transceivers

MAX3453E-MAX3456E

DC ELECTRICAL CHARACTERISTICS (continued)

(V_{BUS} = +4.0V to +5.5V or V_{TRM} = +3.0V to +3.6V, V_L = +1.65V to +3.6V, T_A = T_{MIN} to T_{MAX}, unless otherwise noted. Typical values are at V_{BUS} = +5.0V, V_L = +2.5V, and T_A = +25°C.) (Note 1)

PARAMETER	SYMBOL	CONDITIONS	MIN	TYP	MAX	UNITS
USB Power-Supply Detection Threshold	V _{TH_VBUS}	MAX3453E/MAX3455E, supply lost			3.6	V
		MAX3453E/MAX3455E, supply present	4.0			
		MAX3454E/MAX3456E, supply lost			0.8	
		MAX3454E/MAX3456E, supply present (Note 3)	3.6			
USB Power-Supply Detection Hysteresis	V _{HYST_VBUS}	MAX3453E/MAX3455E		40		mV
		MAX3454E/MAX3456E		75		
V _L Power-Supply Detection Threshold	V _{TH_VL}			0.85		V
DIGITAL INPUTS/OUTPUTS (VP, VM, RCV, SUS, \overline{OE}, SPD, BD, ENUM)						
Input-Voltage Low	V _{IL}	VM, VP, SUS, SPD, ENUM, \overline{OE}			0.3 x V _L	V
Input-Voltage High	V _{IH}	VM, VP, SUS, SPD, ENUM, \overline{OE}	0.7 x V _L			V
Output-Voltage Low	V _{OL}	VM, VP, RCV, BD, I _{OL} = +2mA			0.4	V
Output-Voltage High	V _{OH}	VM, VP, RCV, BD, I _{OH} = -2mA	V _L - 0.4			V
Input Leakage Current	I _{LKG}		-1		+1	μA
Input Capacitance	C _{IN}	Measured from input to GND		10		pF
ANALOG INPUTS/OUTPUTS (D+, D-)						
Differential Input Sensitivity	V _{ID}	V _{D+} - V _{D-}	0.2			V
Differential Common-Mode Voltage	V _{CM}	Includes V _{ID} range	0.8		2.5	V
Single-Ended Input Low Voltage	V _{ILSE}				0.8	V
Single-Ended Input High Voltage	V _{IHSE}		2.0			V
Hysteresis	V _{HYST}			250		mV
Output-Voltage Low	V _{OLD}	R _L = 1.5kΩ to +3.6V			0.3	V
Output-Voltage High	V _{OHD}	R _L = 15kΩ to GND	2.8		3.6	V
Off-State Leakage Current	I _{LZ}		-1		+1	μA
Transceiver Capacitance	C _{IND}	Measured from D ₋ to GND		20		pF
Driver Output Impedance	Z _{DRV}	Steady-state drive	3.5		15.5	Ω
Input Impedance	Z _{IN}	Driver off	10			MΩ
Internal Pullup Resistance	R _{PULLUP}	I _{LOAD} = 500μA (MAX3453E/MAX3454E) (Note 4)	1.425		1.575	kΩ
ESD PROTECTION (D+, D-)						
Human Body Model				±15		kV
IEC 61000-4-2 Contact Discharge				±8		kV

±15kV ESD-Protected USB Transceivers

MAX3453E-MAX3456E

TIMING CHARACTERISTICS

($V_{BUS} = +4.0V$ to $+5.5V$ or $V_{TRM} = +3.0V$ to $+3.6V$, $V_L = +1.65V$ to $+3.6V$, $T_A = T_{MIN}$ to T_{MAX} , unless otherwise noted. Typical values are at $V_{BUS} = +5V$, $V_L = +2.5V$, and $T_A = +25^\circ C$.) (Note 1)

PARAMETER	SYMBOL	CONDITIONS	MIN	TYP	MAX	UNITS
DRIVER CHARACTERISTICS (Full-Speed Mode, $C_L = 50pF$)						
Rise Time	t_{FR}	10% to 90% of $I_{VOHD} - V_{OLD}$, Figures 1, 6	4		20	ns
Fall Time	t_{FF}	90% to 10% of $I_{VOHD} - V_{OLD}$, Figures 1, 6	4		20	ns
Rise/Fall-Time Matching (Note 2)	t_{FR} / t_{FF}	Excluding the first transition from idle state, Figures 1, 6	90		110	%
Output-Signal Crossover Voltage (Note 2)	V_{CRS_F}	Excluding the first transition from idle state, Figures 2, 6	1.3		2.0	V
Driver Propagation Delay	t_{PLH_DRV}	Low-to-high transition, Figures 2, 6			18	ns
	t_{PHL_DRV}	High-to-low transition, Figures 2, 6			18	
Driver Disable Delay	t_{PHZ_DRV}	High-to-off transition, Figure 3			20	ns
	t_{PLZ_DRV}	Low-to-off transition, Figure 3			20	
Driver Enable Delay	t_{PZH_DRV}	Off-to-high transition, Figure 3			20	ns
	t_{PZL_DRV}	Off-to-low transition, Figure 3			20	
DRIVER CHARACTERISTICS (low-speed mode, $C_L = 200pF$ to $600pF$, MAX3454E/MAX3455E/MAX3456E)						
Rise Time	t_{LR}	10% to 90% of $I_{VOHD} - V_{OLD}$, Figures 1, 6	75		300	ns
Fall Time	t_{LF}	90% to 10% of $I_{VOHD} - V_{OLD}$, Figures 1, 6	75		300	ns
Rise/Fall-Time Matching	t_{LR} / t_{LF}	Excluding the first transition from idle state, Figures 1, 6	80		125	%
Output-Signal Crossover Voltage	V_{CRS_L}	Excluding the first transition from idle state, Figures 2, 6	1.3		2.0	V
RECEIVER CHARACTERISTICS ($C_L = 15pF$)						
Differential Receiver Propagation Delay	t_{PLH_RCV}	Low-to-high transition, Figures 4, 6			22	ns
	t_{PHL_RCV}	High-to-low transition, Figures 4, 6			22	
Single-Ended Receiver Propagation Delay	t_{PLH_SE}	Low-to-high transition, Figures 4, 6			12	ns
	t_{PHL_SE}	High-to-low transition, Figures 4, 6			12	
Single-Ended Receiver Disable Delay	t_{PHZ_SE}	High-to-off transition, Figure 5			15	ns
	t_{PLZ_SE}	Low-to-off transition, Figure 5			15	
Single-Ended Receiver Enable Delay	t_{PZH_SE}	Off-to-high transition, Figure 5			15	ns
	t_{PZL_SE}	Off-to-low transition, Figure 5			15	

Note 1: Parameters are 100% production tested at $+25^\circ C$, unless otherwise noted. Limits over temperature are guaranteed by design.

Note 2: Guaranteed by design, not production tested.

Note 3: Production tested to $+2.7V$ for $V_L < +3.0V$.

Note 4: Including external 27Ω series resistor.

±15kV ESD-Protected USB Transceivers

Typical Operating Characteristics

($V_{BUS} = +5.0V$, $V_L = +3.3V$, $T_A = +25^\circ C$, unless otherwise noted.)

MAX3453E-MAX3456E

SINGLE-ENDED RECEIVER PROPAGATION DELAY vs. V_L

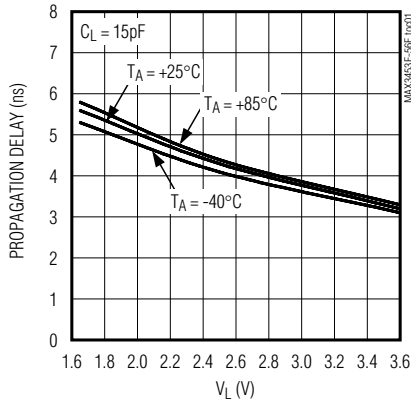

RISE-/FALL-TIME MATCHING (FULL SPEED)

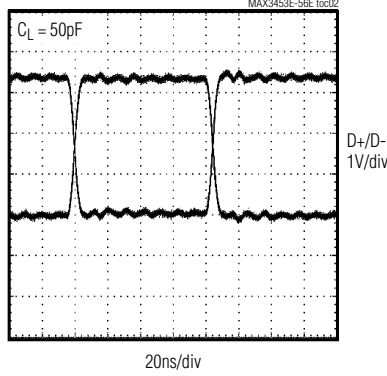

RISE-/FALL-TIME MATCHING (LOW SPEED)

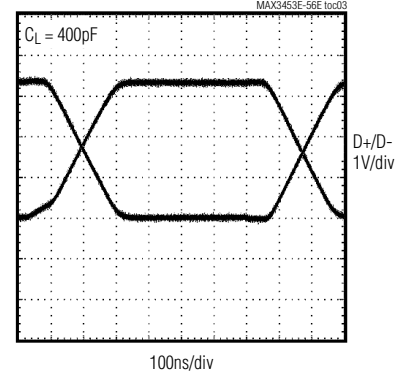

OE, VP, VM TIMING

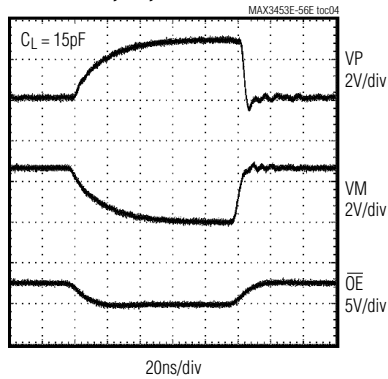

SUPPLY CURRENT vs. D+/D- CAPACITANCE

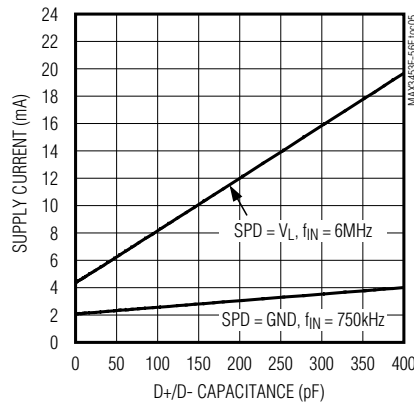

LOGIC SUPPLY CURRENT vs. D+/D- CAPACITANCE

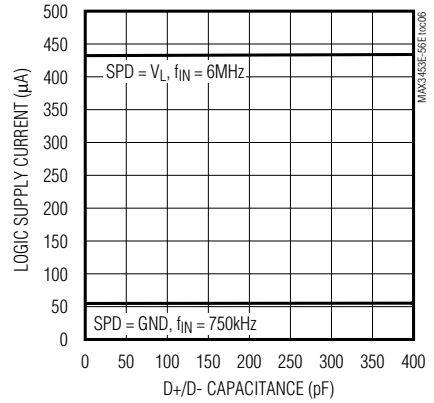

±15kV ESD-Protected USB Transceivers

MAX3453E-MAX3456E

Pin Description

PIN				NAME	FUNCTION
MAX3454E/ MAX3455E/ MAX3456E		MAX3453E			
TSSOP	THIN QFN	TSSOP	THIN QFN		
1	15	1	15	V _L	Digital I/O Connections Logic Supply. Connect a +1.65V to +3.6V supply to V _L . Bypass V _L to GND with a 0.1µF ceramic capacitor.
2	1	—	—	SPD	Speed Selector Input. Connect SPD to GND to select the low-speed data rate (1.5Mbps). Connect SPD to V _L to select the full-speed data rate (12Mbps). The MAX3453E only supports full-speed operation.
3	2	3	2	RCV	Differential Receiver Output. RCV responds to the differential inputs on D+ and D- (see Tables 3, 4). RCV asserts low if SUS = V _L .
4	3	4	3	VP	Receiver Output/Driver Input. VP functions as a receiver output when $\overline{OE} = V_L$. VP duplicates D+ when receiving. VP functions as a driver input when $\overline{OE} = GND$.
5	4	5	4	VM	Receiver Output/Driver Input. VM functions as a receiver output when $\overline{OE} = V_L$. VM duplicates D- when receiving. VM functions as a driver input when $\overline{OE} = GND$.
6, 13*	5, 8, 13*, 16	6	5, 8, 16	N.C.	No Connection. Not internally connected. *Pin 13 is No Connection for MAX3456E only.
7	6	7	6	GND	Ground
8	7	8	7	SUS	Suspend Input. Drive SUS low for normal operation. Drive SUS high to put the MAX3453E-MAX3456E into suspend mode. RCV asserts low in suspend mode. VP and VM remain active in suspend mode.
9	9	9	9	\overline{OE}	Output Enable. Drive \overline{OE} to GND to enable the transmitter outputs. Drive \overline{OE} to V _L to disable the transmitter outputs. \overline{OE} also controls the I/O direction of VP and VM (see Tables 3, 4).
10	10	10	10	D-	USB Input/Output. For $\overline{OE} = GND$, D- functions as a USB output, with VM providing the input signal. For $\overline{OE} = V_L$, D- functions as a USB input, with VM functioning as a single-ended receiver output. Connect a 1.5kΩ resistor from D- to V _{TRM} for low-speed (1.5Mbps) operation (MAX3455E/MAX3456E). Drive ENUM to V _L to connect the internal 1.5kΩ resistor from D- to V _{TRM} for low-speed (MAX3454E, SPD = GND) operation.

±15kV ESD-Protected USB Transceivers

Pin Description (continued)

MAX3453E-MAX3456E

PIN				NAME	FUNCTION
MAX3454E/ MAX3455E/ MAX3456E		MAX3453E			
TSSOP	THIN QFN	TSSOP	THIN QFN		
11	11	11	11	D+	USB Input/Output. For $\overline{OE} = \text{GND}$, D+ functions as a USB output, with VP providing the input signal. For $\overline{OE} = V_L$, D+ functions as a USB input, with VP functioning as a single-ended receiver output. Connect a 1.5kΩ resistor from D+ to VTRM for full-speed (12Mbps) operation (MAX3455E/MAX3456E). Drive ENUM to VL to connect the internal 1.5kΩ resistor (MAX3453E/MAX3454E) from D+ to VTRM for full-speed (MAX3454E, SPD = VL) operation.
12	12	12	12	VTRM	Internal Regulator Output. VTRM provides a regulated +3.3V output. Bypass VTRM to GND with a 1μF (min) ceramic capacitor as close to the device as possible. VTRM normally derives power from VBUS. Alternatively, drive VTRM directly with a +3.3V ±10% supply (MAX3454E/MAX3456E). VTRM provides power to internal circuitry and provides the pullup voltage for an external USB pullup resistor (MAX3455E/MAX3456E). Do not use VTRM to power external circuitry.
13 (MAX3455E only)	13 (MAX3455E only)	13	13	BD	Bus-Detection Output (MAX3453E/MAX3455E). The push-pull BD output asserts low and the device enters sharing mode if VBUS < +3.6V. BD asserts high if VBUS > +4.0V.
13 (MAX3454E only)	13 (MAX3454E only)	2	1	ENUM	Enumerate Function Selection Input (MAX3453E/MAX3454E). Drive ENUM to VL to connect the internal 1.5kΩ resistor between VTRM and D+ or D-, depending on the state of SPD. Drive ENUM to GND to disconnect the internal 1.5kΩ resistor. For SPD = VL, the 1.5kΩ resistor connects to D+. For SPD = GND, the 1.5kΩ resistor connects to D-. For the MAX3453E, the resistor only connects to D+.
14	14	14	14	VBUS	USB Power-Supply Input. Connect a +4.0V to +5.5V power supply to VBUS. VBUS provides power to the internal linear regulator. Bypass VBUS to GND with a 0.1μF ceramic capacitor as close to the device as possible. Connect VBUS and VTRM together when powering the MAX3454E/MAX3456E with an external power supply (+3.3V ±10%).

±15kV ESD-Protected USB Transceivers

MAX3453E-MAX3456E

Functional Diagram

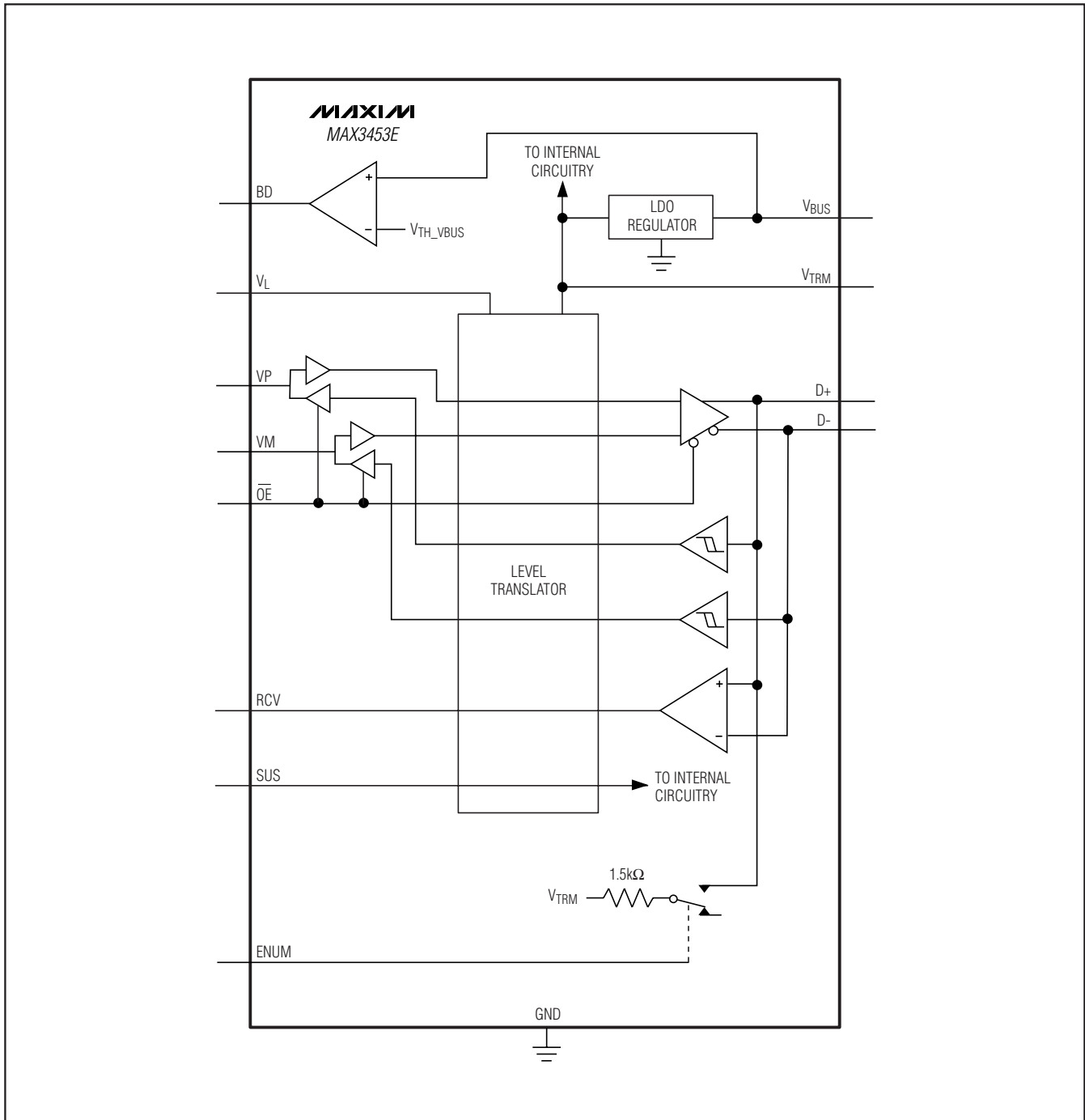

±15kV ESD-Protected USB Transceivers

Functional Diagram (continued)

MAX3453E-MAX3456E

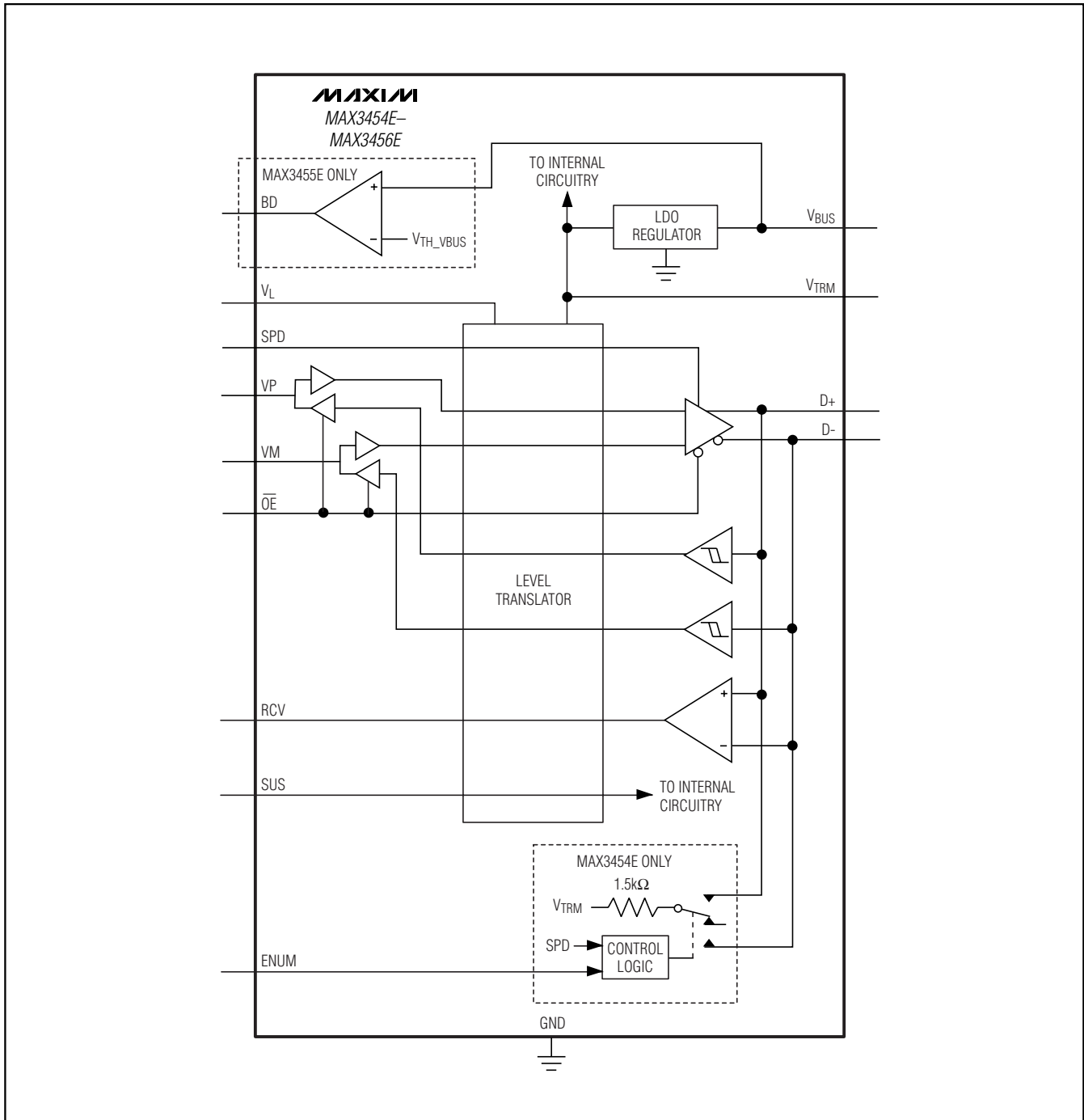

±15kV ESD-Protected USB Transceivers

Detailed Description

The MAX3453E–MAX3456E USB-compliant transceivers convert single-ended or differential logic-level signals to USB signals, and USB signals to single-ended or differential logic-level signals. The MAX3453E fully complies with full-speed (12Mbps) operation under USB specification 2.0. The MAX3454E–MAX3456E fully comply with USB specification 1.1, and full-speed (12Mbps) and low-speed (1.5Mbps) operation under USB specification 2.0. The MAX3453E–MAX3456E operate with V_L as low as +1.65V, ensuring compatibility with low-voltage ASICs.

The MAX3453E–MAX3456E derive power from the USB host (V_{BUS}) or from a single-cell Li+ battery (MAX3454E/MAX3456E) connected to V_{BUS} or from a +3.3V regulated supply connected to V_{BUS} and V_{TRM} . The MAX3453E–MAX3456E meet the physical layer specifications for logic-level supply voltages (V_L) from +1.65V to +3.6V. Integrated ±15kV ESD protection safeguards the D+ and D- USB I/O ports.

The MAX3453E/MAX3454E feature an enumerate function providing an internal 1.5k Ω pullup resistor from D+ (MAX3453E/MAX3454E) or D- (MAX3454E only) to V_{TRM} . The enumerate function disconnects the 1.5k Ω

pullup resistor, allowing the MAX3453E/MAX3454E to simulate a bus disconnect while powered and connected to the USB cable. The MAX3453E/MAX3455E feature a bus-detect output (BD) that asserts high if $V_{BUS} > +4V$. BD asserts low if $V_{BUS} < +3.6V$. The MAX3455E/MAX3456E require external pullup resistors from either D+ or D- to V_{TRM} to utilize the appropriate bus speed. The MAX3456E is pin-for-pin compatible with the Micrel MIC2550A.

Applications Information

Power-Supply Configurations

Normal Operating Mode

Connect V_L and V_{BUS} to system power supplies (Table 1). Connect V_L to a +1.65V to +3.6V supply. Connect V_{BUS} to a +4.0V to +5.5V supply. Alternatively, the MAX3454E/MAX3456E can derive power from a single Li+ battery. Connect the battery to V_{BUS} .

Additionally, the MAX3454E/MAX3456E can derive power from a +3.3V ±10% voltage regulator. Connect V_{BUS} and V_{TRM} to an external +3.3V voltage regulator. V_{BUS} no longer consumes current to power the internal linear regulator in this configuration.

Table 1. Power-Supply Configurations

V_{BUS} (V)	V_{TRM} (V)	V_L (V)	CONFIGURATION	NOTES
4.0 to 5.5	3.0 to 3.6 output	1.65 to 3.6	Normal mode	—
3.1 to 4.5	3.0 to 3.6 output	1.65 to 3.6	Battery supply	MAX3454E/MAX3456E
3.0 to 3.6	3.0 to 3.6 input	1.65 to 3.6	Voltage regulator supply	MAX3454E/MAX3456E
GND or floating	High-Z	1.65 to 3.6	Sharing mode	Table 2
3.0 to 5.5	High-Z	GND or floating	Disable mode	Table 2

Table 2. Disable-Mode and Sharing-Mode Connections

INPUTS/OUTPUTS	DISABLE MODE	SHARING MODE
V_{BUS}/V_{TRM}	+3.0V to +5.5V / High Impedance	<ul style="list-style-type: none"> Floating or connected to GND (MAX3453E/MAX3454E/MAX3456E) / High Impedance < 3.6V (MAX3453E/MAX3455E) / High Impedance
V_L	Floating or connected to GND	1.65V to 3.6V input
D+ and D-	High impedance	High impedance
VP and VM	Invalid*	High impedance for $\overline{OE} = \text{low}$ High for $\overline{OE} = \text{high}$
RCV	Invalid*	Undefined**
SPD (MAX3454E–MAX3456E), SUS, \overline{OE} , ENUM (MAX3453E/MAX3454E)	High impedance	High impedance
BD (MAX3453E/MAX3455E)	Invalid*	Low

*High impedance or low.

**High or low.

±15kV ESD-Protected USB Transceivers

MAX3453E-MAX3456E

Disable Mode

Connect V_{BUS} to a system power supply and leave V_L unconnected or connect to GND. D+ and D- enter a tri-state mode and V_{BUS} (or V_{BUS} and V_{TRM}) consumes less than 20 μ A of supply current. D+ and D- withstand external signals up to +5.5V in disable mode (Table 2).

Sharing Mode

Connect V_L to a system power supply and leave V_{BUS} (or V_{BUS} and V_{TRM}) unconnected or connect to GND. D+ and D- enter a tri-state mode, allowing other circuitry to share the USB D+ and D- lines, and V_L consumes less than 20 μ A of supply current. D+ and D- withstand external signals up to +5.5V in sharing mode (Table 2).

Device Control

\overline{OE}

\overline{OE} controls the direction of communication. Drive \overline{OE} low to transfer data from the logic side to the USB side. For \overline{OE} = low, VP and VM serve as differential driver inputs to the USB transmitter.

Drive \overline{OE} high to transfer data from the USB side to the logic side. For \overline{OE} = high, VP and VM serve as single-ended receiver outputs from the USB inputs (D+ and D-). RCV serves as a differential receiver output, regardless of the state of \overline{OE} .

ENUM (MAX3453E/MAX3454E)

The MAX3453E/MAX3454E feature an enumerate function that allows software control of USB enumeration. USB protocol requires a 1.5k Ω pullup resistor to D+ or D- to indicate the transmission speed to the host (see the SPD section). The MAX3453E/MAX3454E provide an internal 1.5k Ω pullup resistor. Disconnect the pullup resistor from the circuit to simulate the removal of a device from the USB. Drive ENUM low to disconnect the internal pullup resistor. Drive ENUM high to connect the internal pullup resistor. The SPD state (MAX3454E only) determines whether the pullup resistor connects to D+ or D-. For ENUM = high, the internal pullup resistor connects to D+ when SPD = V_L (full speed) or to D- when SPD = GND (low speed). The MAX3453E only supports full-speed operation; therefore, the pullup resistor only connects to D+ or is disconnected.

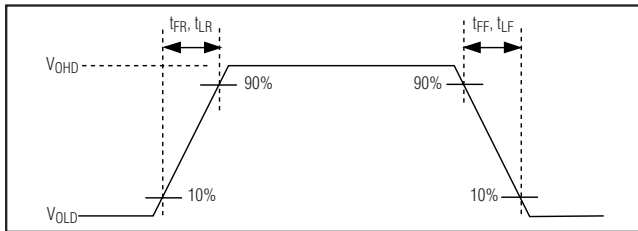

Figure 1. Rise and Fall Times

Table 3a. Transmit Truth Table

($\overline{OE} = 0$, $SUS = 0$)

INPUTS		OUTPUTS			OUTPUT STATE
VP	VM	D+	D-	RCV	
0	0	0	0	X	SE0
0	1	0	1	0	Logic 0
1	0	1	0	1	Logic 1
1	1	1	1	X	Undefined

X = Undefined.

Table 3b. Transmit Truth Table

($\overline{OE} = 0$, $SUS = 1$)

INPUTS		OUTPUTS			OUTPUT STATE
VP	VM	D+	D-	RCV	
0	0	0	0	0	SE0
0	1	0	1	0	Logic 0
1	0	1	0	0	Logic 1
1	1	1	1	0	Undefined

Table 4a. Receive Truth Table

($\overline{OE} = 1$ and $SUS = 0$)

INPUTS		OUTPUTS			OUTPUT STATE
D+	D-	VP	VM	RCV	
0	0	0	0	X	SE0
0	1	0	1	0	Logic 0
1	0	1	0	1	Logic 1
1	1	1	1	X	Undefined

X = Undefined.

Table 4b. Receive Truth Table

($\overline{OE} = 1$ and $SUS = 1$)

INPUTS		OUTPUTS			OUTPUT STATE
D+	D-	VP	VM	RCV	
0	0	0	0	0	SE0
0	1	0	1	0	Logic 0
1	0	1	0	0	Logic 1
1	1	1	1	0	Undefined

±15kV ESD-Protected USB Transceivers

SPD (MAX3454E/MAX3455E/MAX3456E)

SPD sets the transceiver speed. Connect SPD to GND to select the low-speed data rate (1.5Mbps). Connect SPD to V_L to select the full-speed data rate (12Mbps). The MAX3454E provides an internal pullup resistor for selecting the bus speed. The MAX3455E and MAX3456E require an external pullup resistor to D+ or D- to set the bus speed. Connect the 1.5k Ω resistor between D+ and V_{TRM} to set the full-speed (12Mbps) data rate, or connect the 1.5k Ω resistor between D- and V_{TRM} to set the low-speed (1.5Mbps) data rate.

SUS

The SUS state determines whether the MAX3453E-MAX3456E operate in normal mode or in suspend mode. Connect SUS to GND to enable normal operation. Drive SUS high to enable suspend mode. RCV asserts low and VP and VM remain active in suspend mode (Tables 3 and 4). Supply current decreases in suspend mode (see the *Electrical Characteristics*).

BD (MAX3453E/MAX3455E)

The push-pull bus detect (BD) output monitors V_{BUS} and asserts high if V_{BUS} is greater than +4.0V. BD asserts low if V_{BUS} is less than +3.6V and the MAX3453E/MAX3455E enters sharing mode (Table 2).

V_{TRM}

An internal linear regulator generates the V_{TRM} voltage (+3.3V, typ). V_{TRM} derives power from V_{BUS} (see the *Power-Supply Configurations* section). V_{TRM} powers the internal portions of the USB circuitry and provides the pullup voltage for an external USB pullup resistor (MAX3455E/MAX3456E). Bypass V_{TRM} to GND with a 1 μ F ceramic capacitor as close to the device as possible. Do not use V_{TRM} to provide power to external circuitry.

D+ and D-

D+ and D- serve as bidirectional bus connections and are ESD protected to ±15kV (Human Body Model). For \overline{OE} = low, D+ and D- serve as transmitter outputs. For \overline{OE} = high, D+ and D- serve as receiver inputs.

V_{BUS}

For most applications, V_{BUS} connects to the V_{BUS} terminal on the USB connector (see the *Power-Supply Configurations* section). V_{BUS} can also connect to an external supply as low as +3.1V (MAX3454E/MAX3456E). Drive V_{BUS} low to enable sharing mode. Bypass V_{BUS} to GND with a 0.1 μ F ceramic capacitor as close to the device as possible.

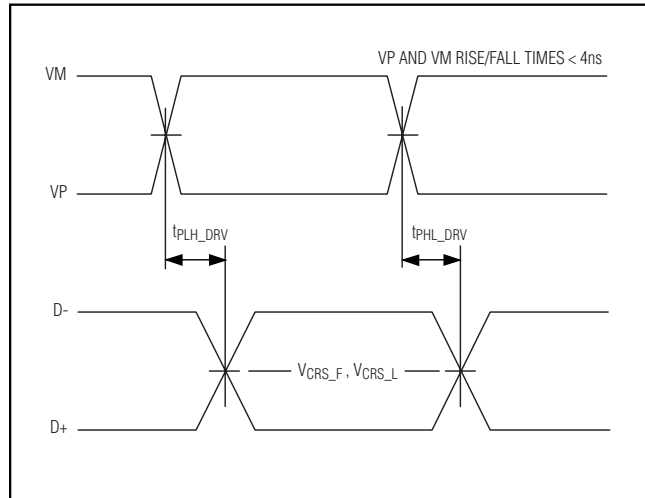

Figure 2. Timing of VP and VM to D+ and D-

External Components

External Resistors

Proper USB operation requires two external resistors, each 27 Ω ±1%, 1/8W (or greater). Install one resistor in series between D+ of the MAX3453E-MAX3456E and D+ on the USB connector. Install the other resistor in series between D- of the MAX3453E-MAX3456E and D- on the USB connector (see *Typical Operating Circuit*).

The MAX3455E/MAX3456E require an external 1.5k Ω pullup resistor between V_{TRM} and D+ or D- to set the bus speed.

External Capacitors

The MAX3453E-MAX3456E require three external capacitors for proper operation. Bypass V_L to GND with a 0.1 μ F ceramic capacitor. Bypass V_{BUS} to GND with a 0.1 μ F ceramic capacitor. Bypass V_{TRM} to GND with a 1 μ F (min) ceramic capacitor. Install all capacitors as close to the device as possible.

Data Transfer

Transmitting Data to the USB

The MAX3453E-MAX3456E transmit data to the USB differentially on D+ and D-. VP and VM serve as differential input signals to the driver (Tables 3a and 3b).

Receiving Data from the USB

To receive data from the USB, drive \overline{OE} high and SUS low. Differential data received by D+ and D- appears as a differential logic signal at RCV. Single-ended receivers on D+ and D- drive VP and VM, respectively (Tables 4a and 4b).

±15kV ESD-Protected USB Transceivers

MAX3453E-MAX3456E

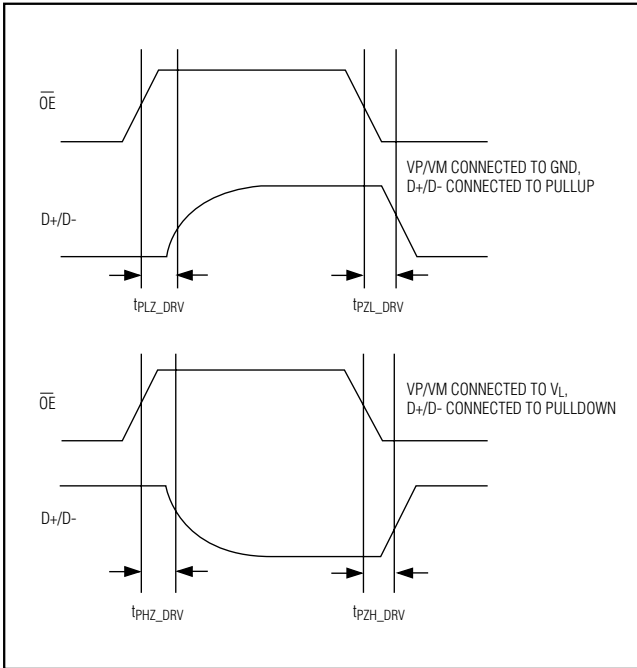

Figure 3. Enable and Disable Timing, Driver

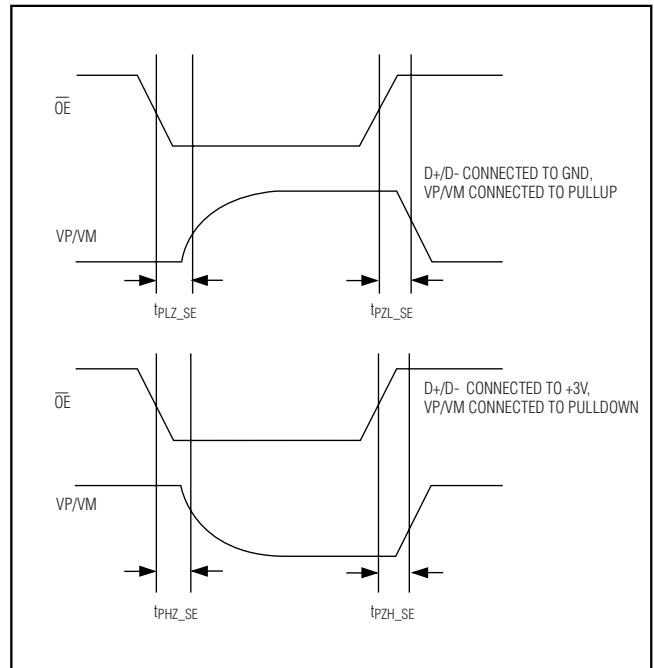

Figure 5. Enable and Disable Timing, Receiver

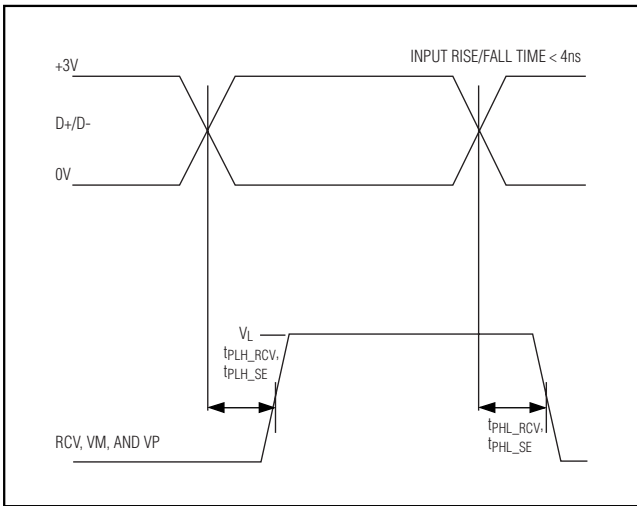

Figure 4. Timing of D+ and D- to RCV, VM, and VP

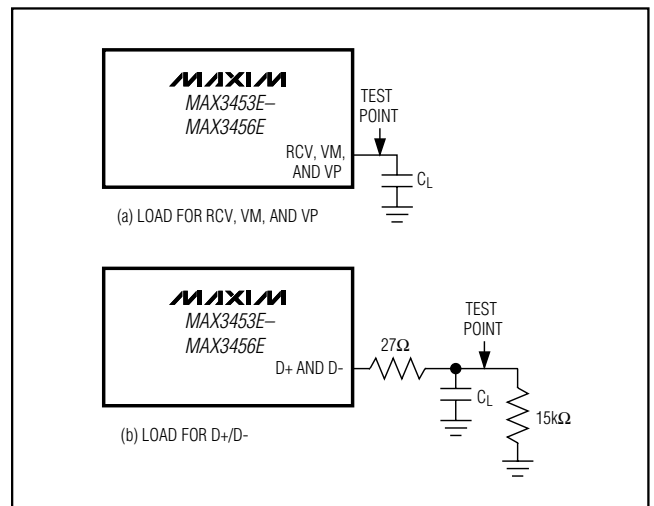

Figure 6. Test Circuits

±15kV ESD-Protected USB Transceivers

ESD Protection

D+ and D- possess extra protection against static electricity to protect the devices up to ±15kV. The ESD structures withstand high ESD in all operating modes: normal operation, suspend mode, and powered down. D+ and D- provide protection to the following limits:

- ±15kV using the Human Body Model
- ±8kV using the Contact Discharge method specified in IEC 61000-4-2

ESD Test Conditions

ESD performance depends on a variety of conditions. Contact Maxim for a reliability report that documents test setup, test methodology, and test results.

Human Body Model

Figure 7 shows the Human Body Model and Figure 8 shows the current waveform generated when discharged into a low impedance. This model consists of a 100pF capacitor charged to the ESD voltage of interest, which then discharges into the test device through a 1.5kΩ resistor.

IEC 61000-4-2

The IEC 61000-4-2 standard covers ESD testing and performance of finished equipment. It does not specifically refer to integrated circuits. The major difference between tests done using the Human Body Model and IEC 61000-4-2 is a higher peak current in IEC 61000-4-2, due to lower series resistance. Hence, the ESD withstand voltage measured to IEC 61000-4-2 generally is lower than that measured using the Human Body Model. Figure 9 shows the IEC 61000-4-2 model. The Contact Discharge method connects the probe to the device before the probe is charged.

Machine Model

The Machine Model for ESD tests all connections using a 200pF storage capacitor and zero discharge resistance. Its objective is to emulate the stress caused by contact that occurs with handling and assembly during manufacturing. All pins require this protection during manufacturing, not just inputs and outputs. After PC board assembly, the Machine Model is less relevant to I/O ports.

Chip Information

TRANSISTOR COUNT: 873

PROCESS: BiCMOS

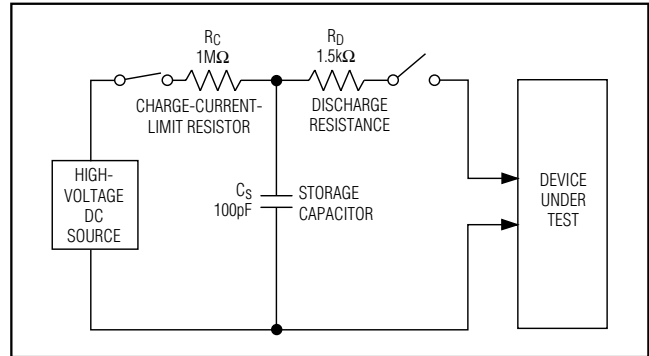

Figure 7. Human Body ESD Test Models

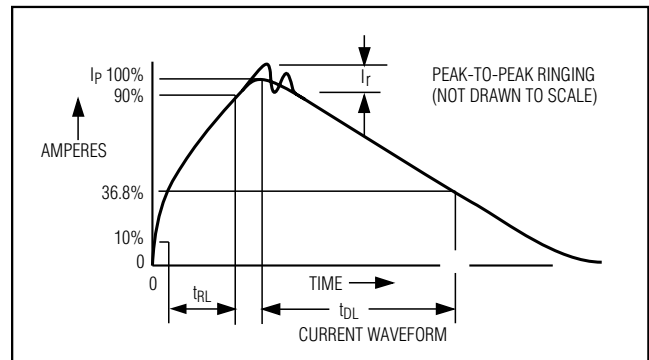

Figure 8. Human Body Model Current Waveform

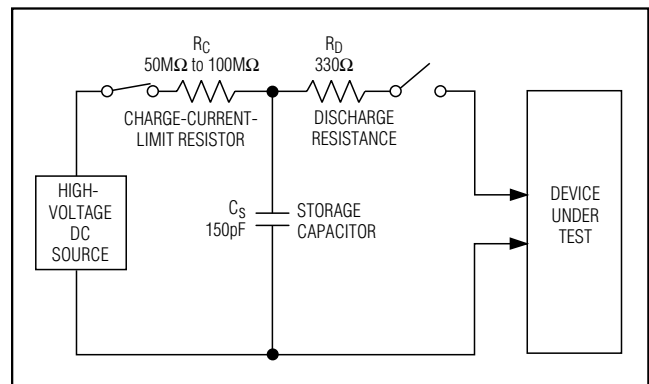
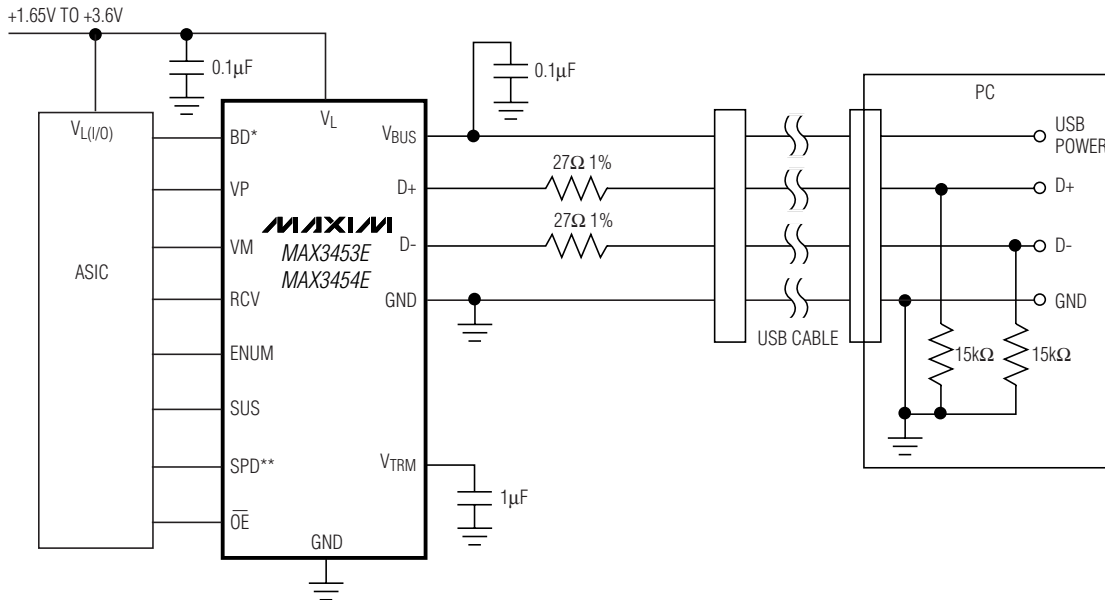

Figure 9. IEC 61000-4-2 ESD Test Model

±15kV ESD-Protected USB Transceivers

Typical Operating Circuits

MAX3453E-MAX3456E



*MAX3453E ONLY.
**MAX3454E ONLY.

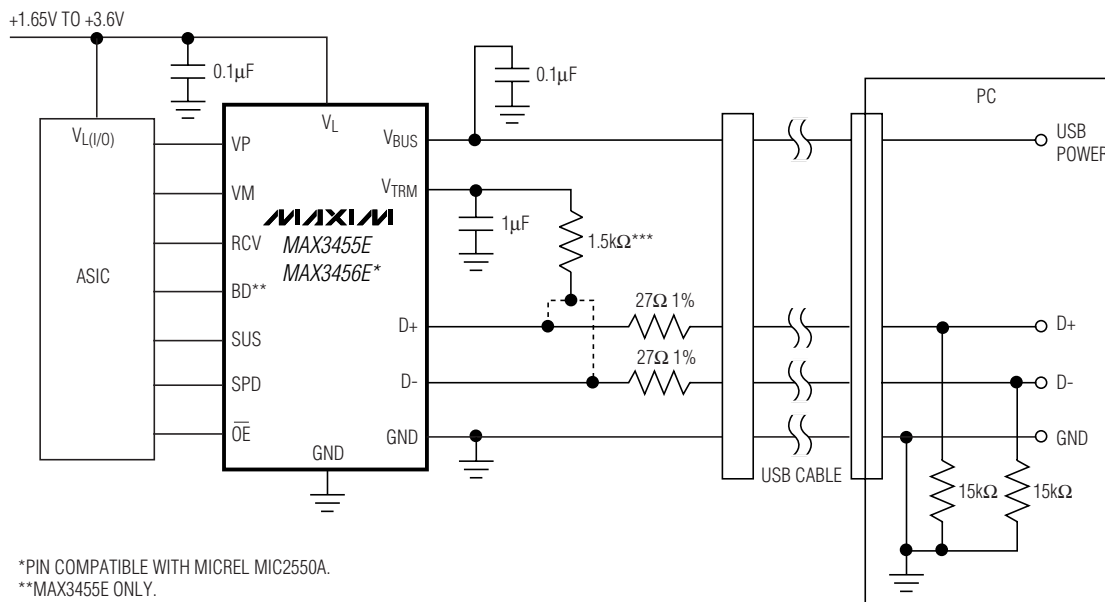

*PIN COMPATIBLE WITH MICREL MIC2550A.
**MAX3455E ONLY.
***CONNECT TO D+ FOR FULL-SPEED OPERATION. CONNECT TO D- FOR LOW-SPEED OPERATION.

±15kV ESD-Protected USB Transceivers

MAX3453E-MAX3456E

Pin Configurations

TOP VIEW

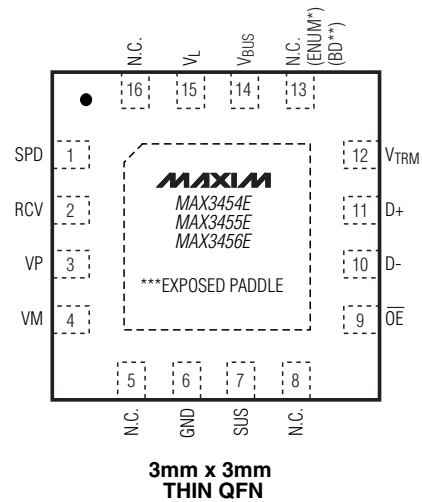
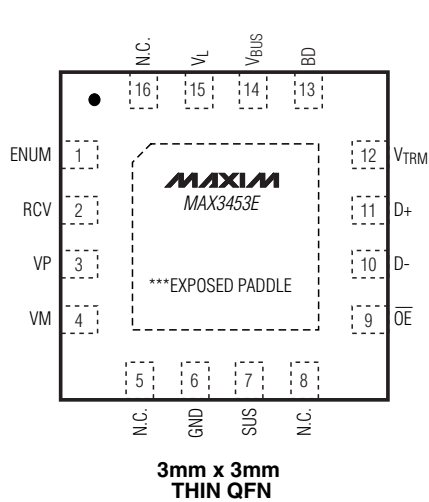
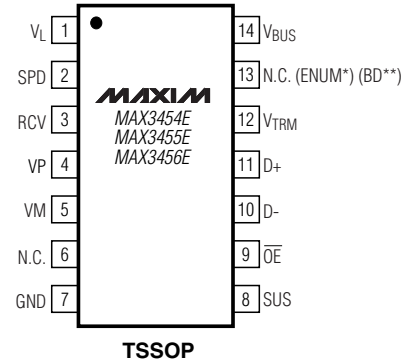
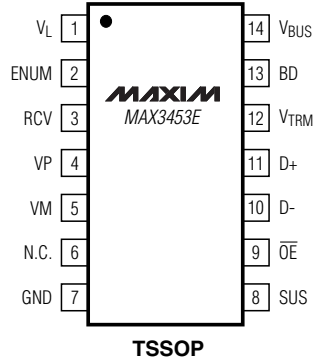

*MAX3454E ONLY.

**MAX3455E ONLY.

***CONNECT EXPOSED PADDLE TO GND OR LEAVE FLOATING.

±15kV ESD-Protected USB Transceivers

Package Information

(The package drawing(s) in this data sheet may not reflect the most current specifications. For the latest package outline information, go to www.maxim-ic.com/packages.)

MAX3453E-MAX3456E

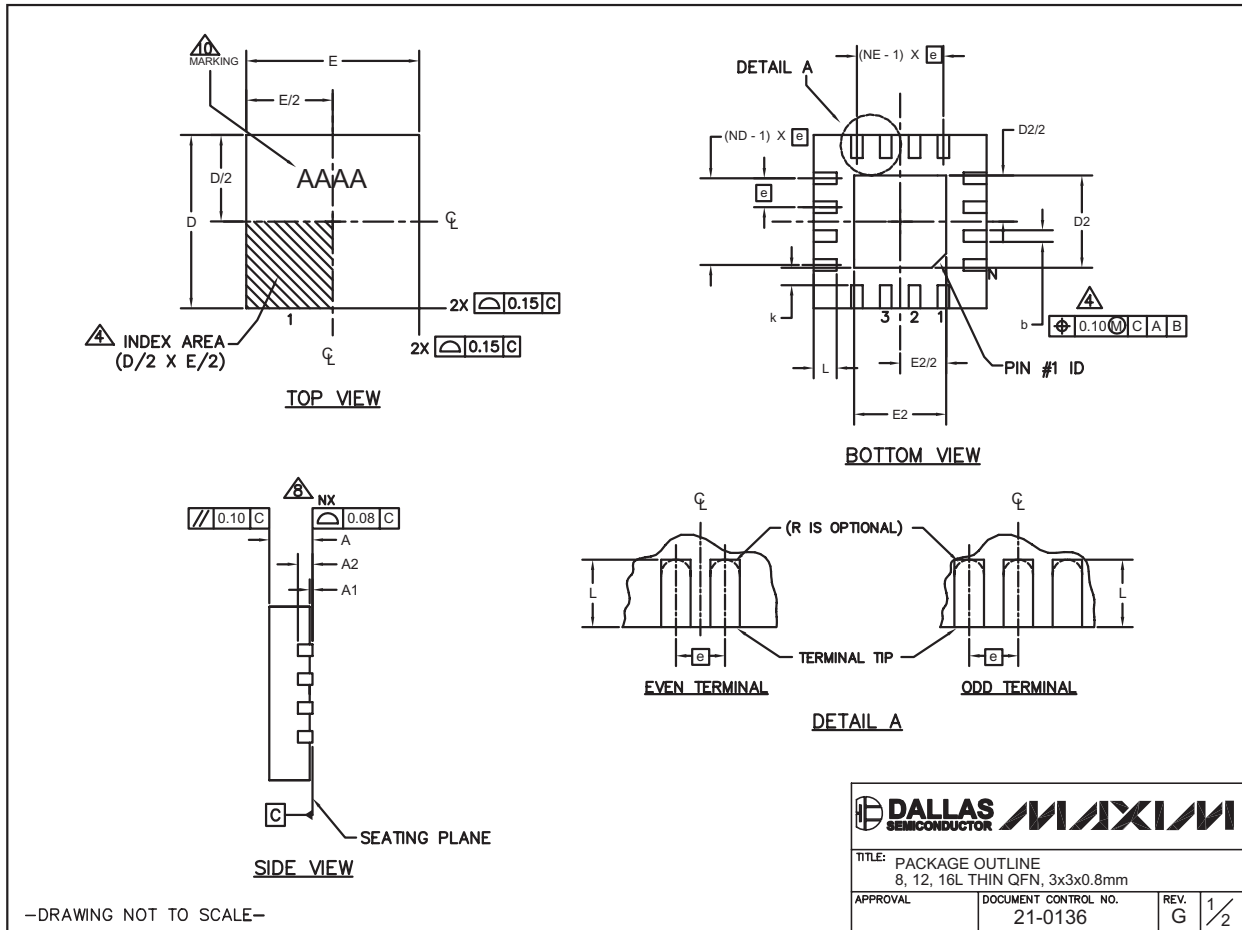

-DRAWING NOT TO SCALE-

TITLE: PACKAGE OUTLINE 8, 12, 16L THIN QFN, 3x3x0.8mm		
APPROVAL	DOCUMENT CONTROL NO. 21-0136	REV. G 1/2

±15kV ESD-Protected USB Transceivers

Package Information (continued)

(The package drawing(s) in this data sheet may not reflect the most current specifications. For the latest package outline information, go to www.maxim-ic.com/packages.)

PKG REF.	8L 3x3			12L 3x3			16L 3x3		
	MIN.	NOM.	MAX.	MIN.	NOM.	MAX.	MIN.	NOM.	MAX.
A	0.70	0.75	0.80	0.70	0.75	0.80	0.70	0.75	0.80
b	0.25	0.30	0.35	0.20	0.25	0.30	0.20	0.25	0.30
D	2.90	3.00	3.10	2.90	3.00	3.10	2.90	3.00	3.10
E	2.90	3.00	3.10	2.90	3.00	3.10	2.90	3.00	3.10
e	0.65 BSC.			0.50 BSC.			0.50 BSC.		
L	0.35	0.55	0.75	0.45	0.55	0.65	0.30	0.40	0.50
N	8			12			16		
ND	2			3			4		
NE	2			3			4		
A1	0	0.02	0.05	0	0.02	0.05	0	0.02	0.05
A2	0.20 REF			0.20 REF			0.20 REF		
k	0.25	-	-	0.25	-	-	0.25	-	-

PKG. CODES	EXPOSED PAD VARIATIONS						PIN ID	JEDEC	DOWN BONDS ALLOWED
	D2			E2					
	MIN.	NOM.	MAX.	MIN.	NOM.	MAX.			
TQ833-1	0.25	0.70	1.25	0.25	0.70	1.25	0.35 x 45j	WEEC	NO
T1233-1	0.95	1.10	1.25	0.95	1.10	1.25	0.35 x 45j	WEED-1	NO
T1233-3	0.95	1.10	1.25	0.95	1.10	1.25	0.35 x 45j	WEED-1	YES
T1233-4	0.95	1.10	1.25	0.95	1.10	1.25	0.35 x 45j	WEED-1	YES
T1633-1	0.95	1.10	1.25	0.95	1.10	1.25	0.35 x 45j	WEED-2	NO
T1633-2	0.95	1.10	1.25	0.95	1.10	1.25	0.35 x 45j	WEED-2	YES
T1633F-3	0.65	0.80	0.95	0.65	0.80	0.95	0.225 x 45j	WEED-2	N/A
T1633FH-3	0.65	0.80	0.95	0.65	0.80	0.95	0.225 x 45j	WEED-2	N/A
T1633-4	0.95	1.10	1.25	0.95	1.10	1.25	0.35 x 45j	WEED-2	NO

NOTES:

- DIMENSIONING & TOLERANCING CONFORM TO ASME Y14.5M-1994.
- ALL DIMENSIONS ARE IN MILLIMETERS. ANGLES ARE IN DEGREES.
- N IS THE TOTAL NUMBER OF TERMINALS.
- THE TERMINAL #1 IDENTIFIER AND TERMINAL NUMBERING CONVENTION SHALL CONFORM TO JESD 95-1 SPP-012. DETAILS OF TERMINAL #1 IDENTIFIER ARE OPTIONAL, BUT MUST BE LOCATED WITHIN THE ZONE INDICATED. THE TERMINAL #1 IDENTIFIER MAY BE EITHER A MOLD OR MARKED FEATURE.
- DIMENSION b APPLIES TO METALLIZED TERMINAL AND IS MEASURED BETWEEN 0.20 mm AND 0.25 mm FROM TERMINAL TIP.
- ND AND NE REFER TO THE NUMBER OF TERMINALS ON EACH D AND E SIDE RESPECTIVELY.
- DEPOPULATION IS POSSIBLE IN A SYMMETRICAL FASHION.
- COPLANARITY APPLIES TO THE EXPOSED HEAT SINK SLUG AS WELL AS THE TERMINALS.
- DRAWING CONFORMS TO JEDEC MO220 REVISION C.
- MARKING IS FOR PACKAGE ORIENTATION REFERENCE ONLY.
- NUMBER OF LEADS SHOWN ARE FOR REFERENCE ONLY.

—DRAWING NOT TO SCALE—

	
TITLE: PACKAGE OUTLINE 8, 12, 16L THIN QFN, 3x3x0.8mm	
APPROVAL	DOCUMENT CONTROL NO. 21-0136
REV. G	2/2

±15kV ESD-Protected USB Transceivers

Package Information (continued)

(The package drawing(s) in this data sheet may not reflect the most current specifications. For the latest package outline information, go to www.maxim-ic.com/packages.)

MAX3453E-MAX3456E

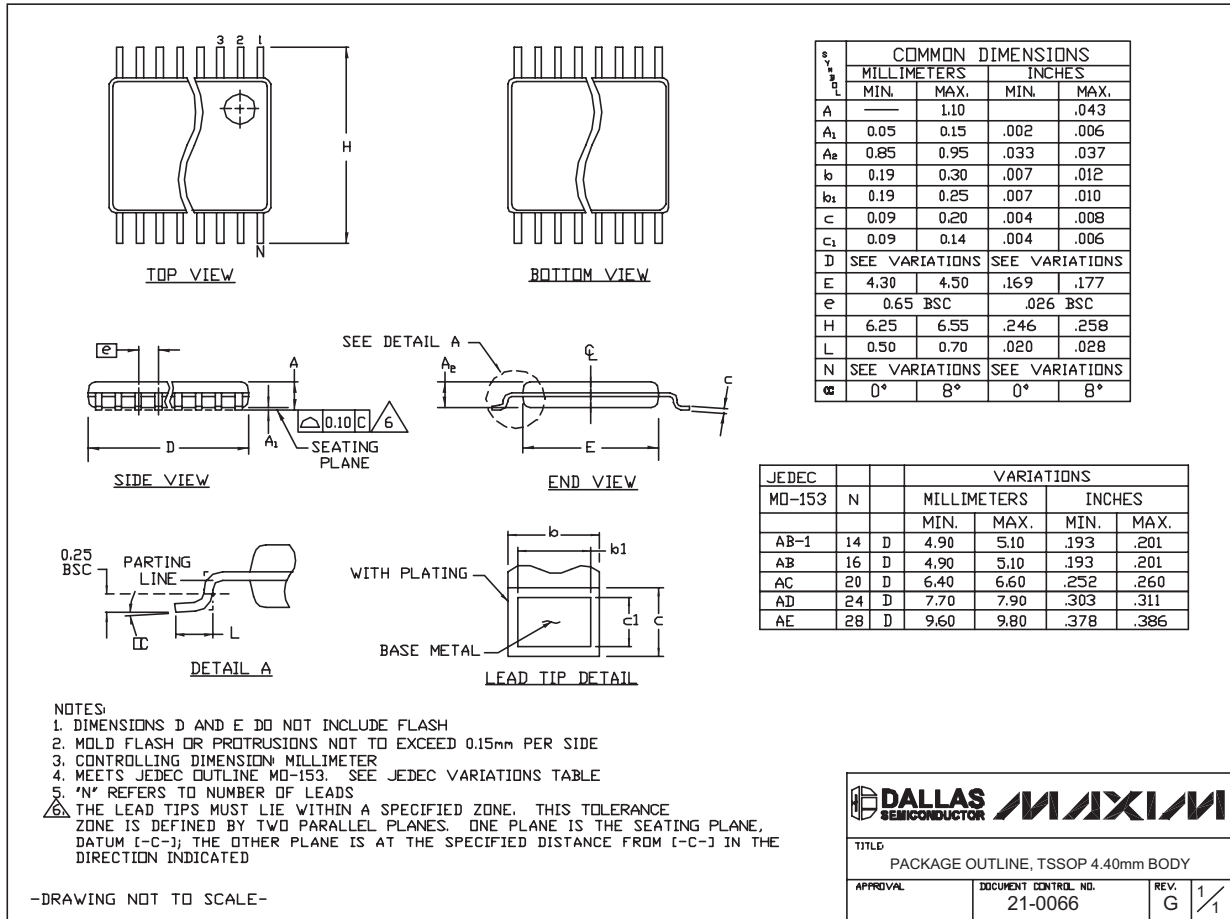

TSSOP4.40mm.EPS

Revision History

Pages changed at Rev1: 1, 14, 19, slide

Maxim cannot assume responsibility for use of any circuitry other than circuitry entirely embodied in a Maxim product. No circuit patent licenses are implied. Maxim reserves the right to change the circuitry and specifications without notice at any time.

Maxim Integrated Products, 120 San Gabriel Drive, Sunnyvale, CA 94086 408-737-7600 _____ 19

© 2006 Maxim Integrated Products

MAXIM is a registered trademark of Maxim Integrated Products.