

7414, LS14 Schmitt Triggers

Hex Inverter Schmitt Trigger
Product Specification

Logic Products

DESCRIPTION

The '14 contains six logic inverters which accept standard TTL input signals and provide standard TTL output levels. They are capable of transforming slowly changing input signals into sharply defined, jitter-free output signals. In addition, they have greater noise margin than conventional inverters.

Each circuit contains a Schmitt trigger followed by a Darlington level shifter and a phase splitter driving a TTL totem-pole output. The Schmitt trigger uses positive feedback to effectively speed-up slow input transition, and provide different input threshold voltages for positive and negative-going transitions. This hysteresis between the positive-going and negative-going input thresholds (typically 800mV) is determined internally by resistor ratios and is essentially insensitive to temperature and supply voltage variations.

TYPE	TYPICAL PROPAGATION DELAY	TYPICAL SUPPLY CURRENT (TOTAL)
7414	15ns	31mA
74LS14	15ns	10mA

ORDERING CODE

PACKAGES	COMMERCIAL RANGE $V_{CC} = 5V \pm 5\%$; $T_A = 0^\circ C$ to $+70^\circ C$
Plastic DIP	N7414N, N74LS14N
Plastic SO	N74LS14D

NOTE:

For information regarding devices processed to Military Specifications, see the Signetics Military Products Data Manual.

INPUT AND OUTPUT LOADING AND FAN-OUT TABLE

PINS	DESCRIPTION	74	74LS
A	Inputs	1uI	1LSuI
Y	Output	10uI	10LSuI

NOTE:

Where a 74 unit load (uI) is understood to be $40\mu A I_{IH}$ and $-1.6mA I_{IL}$, and 74LS unit load (LSuI) is $20\mu A I_{IH}$ and $-0.4mA I_{IL}$.

PIN CONFIGURATION

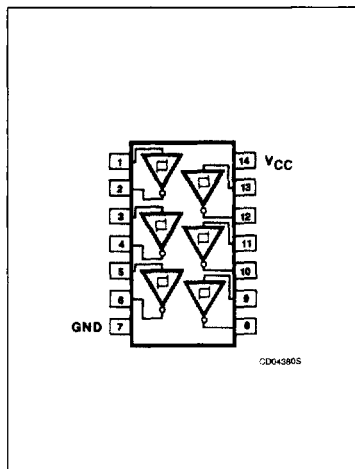

LOGIC SYMBOL

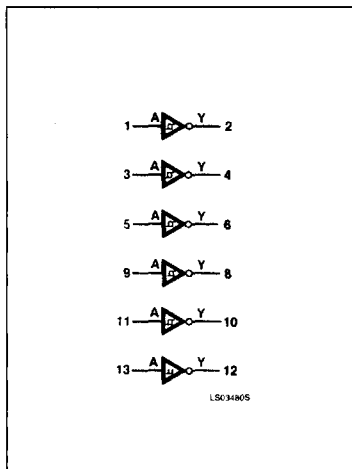

LOGIC SYMBOL (IEEE/IEC)

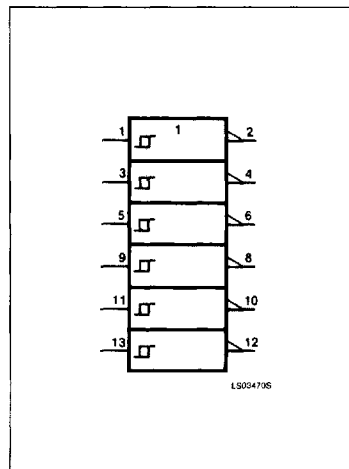

Schmitt Triggers

7414, LS14

ABSOLUTE MAXIMUM RATINGS (Over operating free-air temperature range unless otherwise noted.)

PARAMETER	74	74LS	UNIT
V _{CC} Supply voltage	7.0	7.0	V
V _{IN} Input voltage	-0.5 to +5.5	-0.5 to +7.0	V
I _{IN} Input current	-30 to +5	-30 to +1	mA
V _{OUT} Voltage applied to output in HIGH output state	-0.5 to +V _{CC}	-0.5 to +V _{CC}	V
T _A Operating free-air temperature range	0 to 70		°C

RECOMMENDED OPERATING CONDITIONS

PARAMETER	74			74LS			UNIT
	Min	Nom	Max	Min	Nom	Max	
V _{CC} Supply voltage	4.75	5.0	5.25	4.75	5.0	5.25	V
I _{IK} Input clamp current			-12			-18	mA
I _{OH} HIGH-level output current			-800			-400	μA
I _{OL} LOW-level output current			16			8	mA
T _A Operating free-air temperature	0		70	0		70	°C

TEST CIRCUITS AND WAVEFORMS

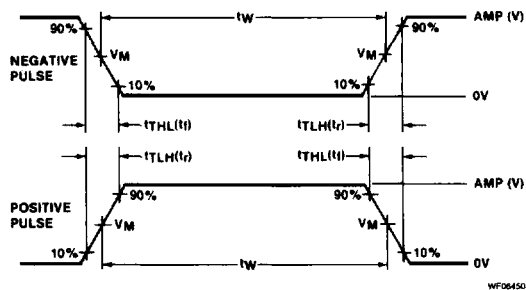
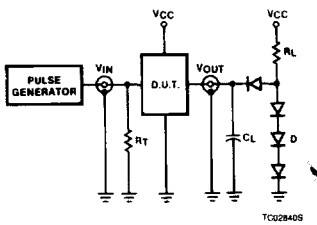

V_M = 1.3V for 74LS; V_M = 1.5V for all other TTL families.

Test Circuit For 74 Totem-Pole Outputs

DEFINITIONS

R_L = Load resistor to V_{CC}; see AC CHARACTERISTICS for value.

C_L = Load capacitance includes jig and probe capacitance; see AC CHARACTERISTICS for value.

R_T = Termination resistance should be equal to Z_{OUT} of Pulse Generators.

D = Diodes are 1N916, 1N3064, or equivalent.

t_{TLH}, t_{THL} Values should be less than or equal to the table entries.

Input Pulse Definition

FAMILY	INPUT PULSE REQUIREMENTS				
	Amplitude	Rep. Rate	Pulse Width	t _{TLH}	t _{THL}
74	3.0V	1MHz	500ns	7ns	7ns
74LS	3.0V	1MHz	500ns	15ns	6ns
74S	3.0V	1MHz	500ns	2.5ns	2.5ns

Schmitt Triggers

7414, LS14

DC ELECTRICAL CHARACTERISTICS (Over recommended operating free-air temperature range unless otherwise noted.)

PARAMETER	TEST CONDITIONS ¹	7414			74LS14			UNIT
		Min	Typ ²	Max	Min	Typ ²	Max	
V _{T+} Positive-going threshold	V _{CC} = 5.0V	1.5	1.7	2.0	1.4	1.6	1.9	V
V _{T-} Negative-going threshold	V _{CC} = 5.0V	0.6	0.9	1.1	0.5	0.8	1.0	V
ΔV _T Hysteresis (V _{T+} - V _{T-})	V _{CC} = 5.0V	0.4	0.8		0.4	0.8		V
V _{OH} HIGH-level output voltage	V _{CC} = MIN, V _I = V _{T-MIN} , I _{OH} = MAX	2.4	3.4		2.7	3.4		V
V _{OL} LOW-level output voltage	V _{CC} = MIN, V _I = V _{T+MAX}	I _{OL} = MAX		0.2	0.4	0.35	0.5	V
		I _{OL} = 4mA (74LS)				0.25	0.4	V
V _{IK} Input clamp voltage	V _{CC} = MIN, I _I = I _{IK}			-1.5			-1.5	V
I _{T+} Input current at positive-going threshold	V _{CC} = 5.0V, V _I = V _{T+}	-0.43			-0.14			mA
I _{T-} Input current at negative-going threshold	V _{CC} = 5.0V, V _I = V _{T-}	-0.56			-0.18			mA
I _I Input current at maximum input voltage	V _{CC} = MAX	V _I = 5.5V		1.0				mA
		V _I = 7.0V				0.1		mA
I _{IH} HIGH-level input current	V _{CC} = MAX	V _I = 2.4V		40				μA
		V _I = 2.7V				20		μA
I _{IL} LOW-level input current	V _{CC} = MAX, V _I = 0.4V			-1.2			-0.4	mA
I _{OS} Short-circuit output current ³	V _{CC} = MAX	-18		-55	-20		-100	mA
I _{CC} Supply current (total)	V _{CC} = MAX	I _{CCH} Outputs HIGH	22	36	8.6	16		mA
		I _{CCL} Outputs LOW	39	60	12	21		mA

NOTES:

- For conditions shown as MIN or MAX, use the appropriate value specified under recommended operating conditions for the applicable type.
- All typical values are at V_{CC} = 5V, T_A = 25°C.
- I_{OS} is tested with V_{OUT} = +0.5V and V_{CC} = V_{CC} MAX + 0.5V. Not more than one output should be shorted at a time and duration of the short circuit should not exceed one second.

FUNCTION TABLE

INPUT	OUTPUT
A	Y
0	1
1	0

AC WAVEFORM

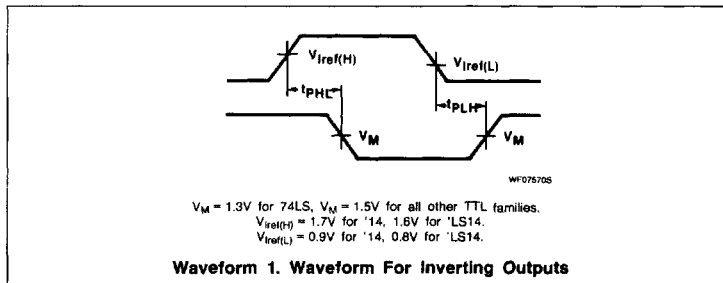

Schmitt Triggers

7414, LS14

AC ELECTRICAL CHARACTERISTICS $T_A = 25^\circ\text{C}$, $V_{CC} = 5.0\text{V}$

PARAMETER	TEST CONDITIONS	74		74LS		UNIT
		$C_L = 15\text{pF}$, $R_L = 400\Omega$		$C_L = 15\text{pF}$, $R_L = 2\text{k}\Omega$		
		Min	Max	Min	Max	
t_{PLH} t_{PHL}	Propagation delay	Waveform 1		22	22	ns

TYPICAL PERFORMANCE CHARACTERISTICS

