

Helping Customers Innovate, Improve & Grow

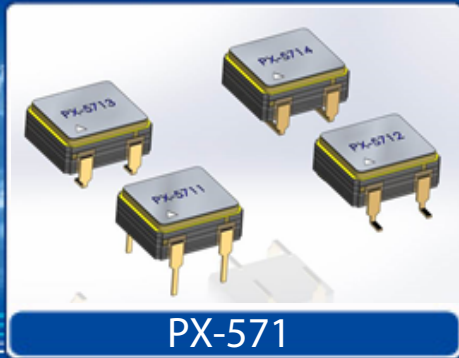

Features

- Frequency: 1 to 125 MHz
- 8X9 Leaded Package (4 lead options)
- Fully RoHS Compliant *
- Surface Mount, Low Profile
- High Shock Survival
- No pure tin is used in this product
- Made in USA

Applications

- Low voltage clock applications
- Military Portable Radios
- Avionics and Instrumentation
- Test and Measurement Equipment
- Medical Equipment
- Navigation



* (Except parts with Sn-Pb Solder Coated Option)

Performance Specifications

Parameter	Min	Typ	Max	Units	Condition
Frequency Stabilities¹					
vs. operating temperature range (referenced to +25°C)	-15		+15	ppm	0... +70°C
	-25		+25	ppm	
	-50		+50	ppm	
	-100		+100	ppm	
	-25		+25	ppm	
-50		+50	ppm		
-100		+100	ppm		
	-50		+50	ppm	-55... +85°C
	-100		+100	ppm	
	-50		+50	ppm	-55... +105°C
	-100		+100	ppm	
Initial tolerance	-50		+50	ppm	@+25°C
	-100		+100	ppm	

Performance Specifications

Parameter	Min	Typ	Max	Units	Condition
Overall tolerance (Referenced to +25°C) (includes operating temperature and initial accuracy)	-20		+20	ppm	0... +70°C
	-25		+25	ppm	
	-50		+50	ppm	
	-100		+100	ppm	
	-25		+25	ppm	-40... +85°C
-50		+50	ppm		
-100		+100	ppm		
	-50		+50	ppm	-55... +85°C
	-65		+65	ppm	
	-100		+100	ppm	
	-50		+50	ppm	
-65		+65	ppm		
-100		+100	ppm		
vs. supply voltage change vs. load change vs. aging / 1st year vs. aging / year (following years)	-2		+2	ppm	VS ± 5% Load ± 5% after 30 days of operation
	-1		+1	ppm	
	-3		+3	ppm	
	-1		+1	ppm	
Supply Voltage (Vs)					
Supply voltage	4.75	5.0	5.25	VDC	
Supply voltage	3.135	3.3	3.465	VDC	
Supply voltage	2.375	2.5	2.625	VDC	
Supply voltage	1.71	1.8	1.89	VDC	
Current consumption (+5 VDC)			15 20 40	mA mA mA	ACMOS or TTL 1.0 to 23.9 MHz ACMOS or TTL 24 to 49.9 MHz ACMOS or TTL 50 to 125.00 MHz
Current consumption (+3.3 VDC or +2.5 VDC)			6 8 12 16 40	mA mA mA mA mA	ACMOS 1.0 to 14.9 MHz ACMOS 15.0 to 39.9 MHz ACMOS 40.0 to 59.9 MHz ACMOS 60.0 to 84.9 MHz ACMOS 85.0 to 125.0 MHz
Current consumption (+1.8 VDC)			1.5 2 3 4 10	mA mA mA mA mA	ACMOS 1.0 to 14.9 MHz ACMOS 15.0 to 39.9 MHz ACMOS 40.0 to 59.9 MHz ACMOS 60.0 to 84.9 MHz ACMOS 85.0 to 125.0 MHz

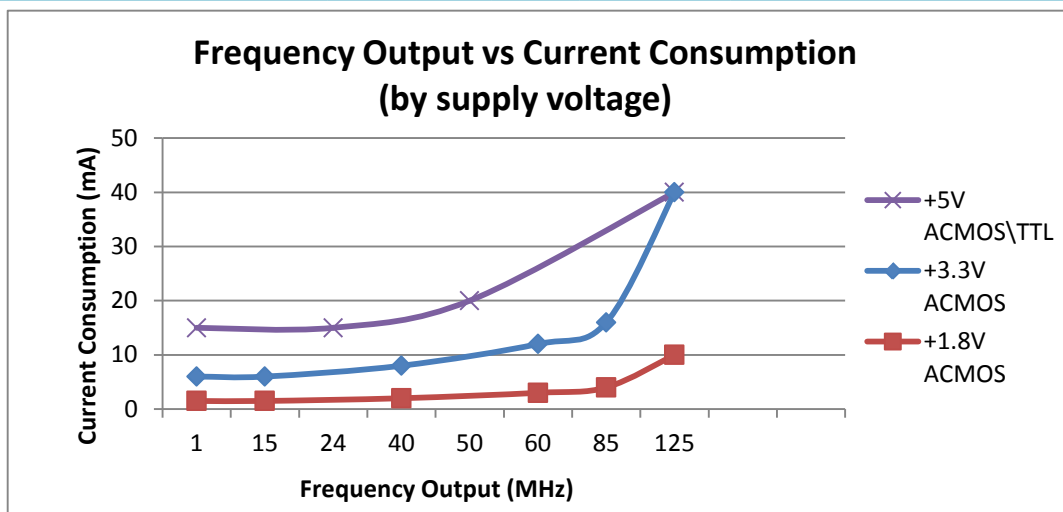

Performance Specifications

Parameter	Min	Typ	Max	Units	Condition
RF Output					
Signal	HCMOS / AC MOS				
Load		15	50	pF	
Signal Level (Vol)			0.5 0.3 0.25 0.2	VDC VDC VDC VDC	with Vs=5.0V and 15pF load with Vs=3.3V and 15pF load with Vs= 2.5V and 15pF load with Vs= 1.8V and 15pF load
Signal Level (Voh)	4.5 3.0 2.25 1.62			VDC VDC VDC VDC	with Vs=5.0V and 15pF load with Vs=3.3V and 15pF load with Vs=2.5V and 15pF load with Vs=1.8V and 15pF load
Rise and fall times for AC MOS (measured 10% to 90%)			10 6 3	ns ns ns	1.0 to 23.9 MHz 24.0 to 79.9 MHz 80.0 to 125.0 MHz
Duty cycle	45 40		55 60	% %	@ 50% < 15 MHz @ 50% => 15 MHz
Signal	TTL				
Load			10	TTL	
Signal Level (Vol)			0.5	VDC	with Vs=5.0V and 10 TTL load
Signal Level (Voh)	2.4			VDC	with Vs=5.0V and 10 TTL load
Rise and fall times for AC MOS (measured 20% to 80%)			5 3	ns ns	1.0 to 23.9 MHz 24.0 to 125 MHz
Duty cycle	45 40		55 60	% %	@ 1.4V < 15 MHz @ 1.4V >= 15 MHz
Absolute Maximum Ratings					
Supply voltage (Vs)			7.0	V	with Vs=5.0VDC and 3.3 VDC
Supply voltage (Vs)			3.6	V	with Vs=2.5VDC and 1.8 VDC
Operable temperature range	-55		+125	°C	
Storage temperature range	-62		+125	°C	

Additional Parameters		
Screening	Vectron Verification	
	Class B, MIL-PRF-55310	
Output Enable Hi	Logic "0" input = Outputs disabled (Tri-state) Logic "1" or floating input = Outputs enabled)	
Weight	< 2 grams	
Processing & Packing	Handling & processing note	

Standard Environmentals	
Vibration	MIL-STD-202, Method 204, Condition G (30 G, 10Hz-2000Hz)
Shock	MIL-STD-202, Method 213, Condition I (100 G, 6ms, Sawtooth)
Acceleration	MIL-STD-883, Method 2001, Condition A (5000 G, Y1 Plane)
Temperature Cycling	MIL-STD-883, Method 1010, Condition B
Thermal Shock	MIL-STD-202, Method 107, Condition B
Solderability	MIL-STD-202, Method 208
Leak Test (Fine and Gross)	MIL-STD-883, Method 1014, Condition A1 and C1

Outline Drawing / Enclosure (Dimensions in inches (mm))

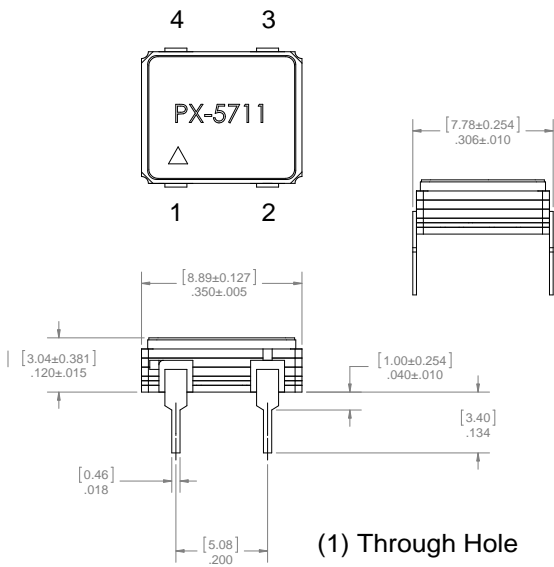

(1) Through Hole

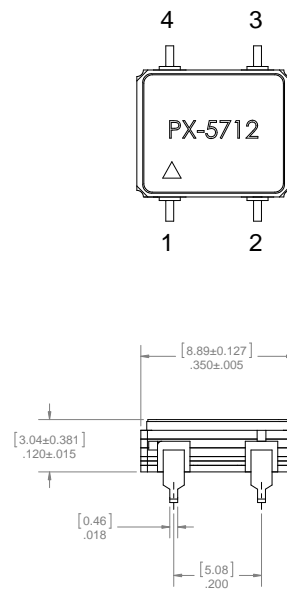

(2) Gull Wing

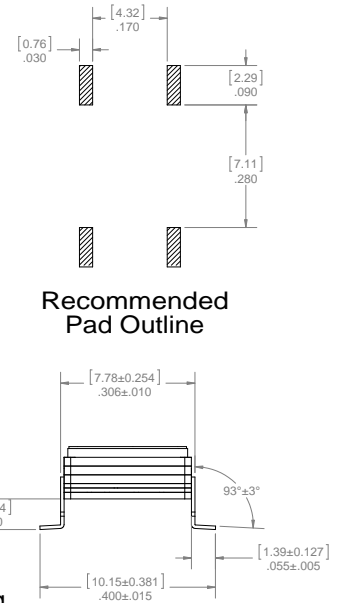

Recommended Pad Outline

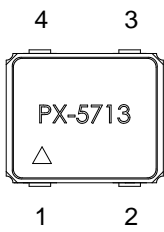

Recommended Pad Outline

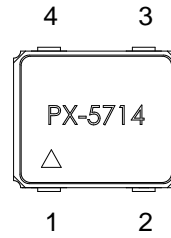
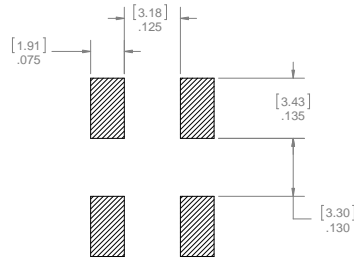

Recommended Pad Outline

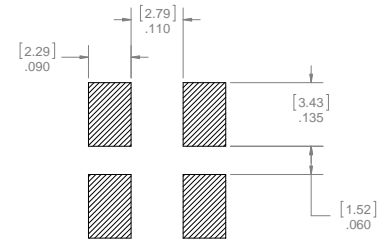

(3) Inward L Type I (J Lead compatible)

(4) Inward L Type II (M55310 compatible)

Standard Shipping Method

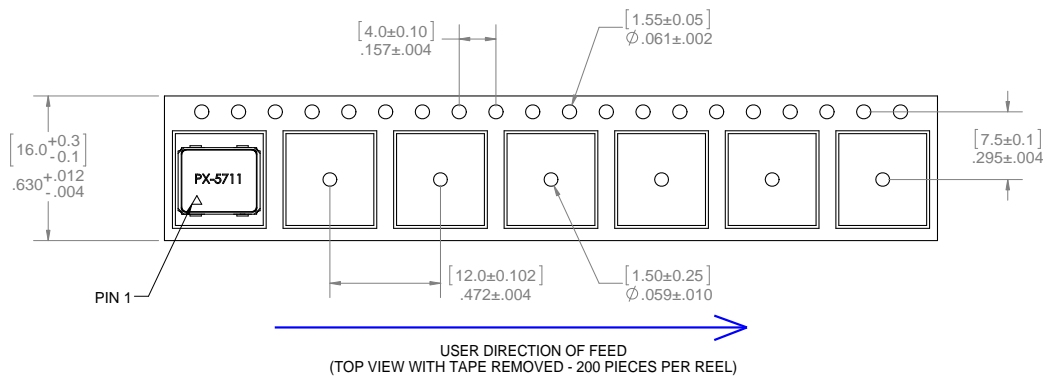

USER DIRECTION OF FEED
(TOP VIEW WITH TAPE REMOVED - 200 PIECES PER REEL)

Pin Connections	
1	Enable/Disable or N/C
2	Ground (Case)
3	RF Output
4	Supply Voltage

Recommended Reflow Profiles for Pb-Free & Sn-Pb

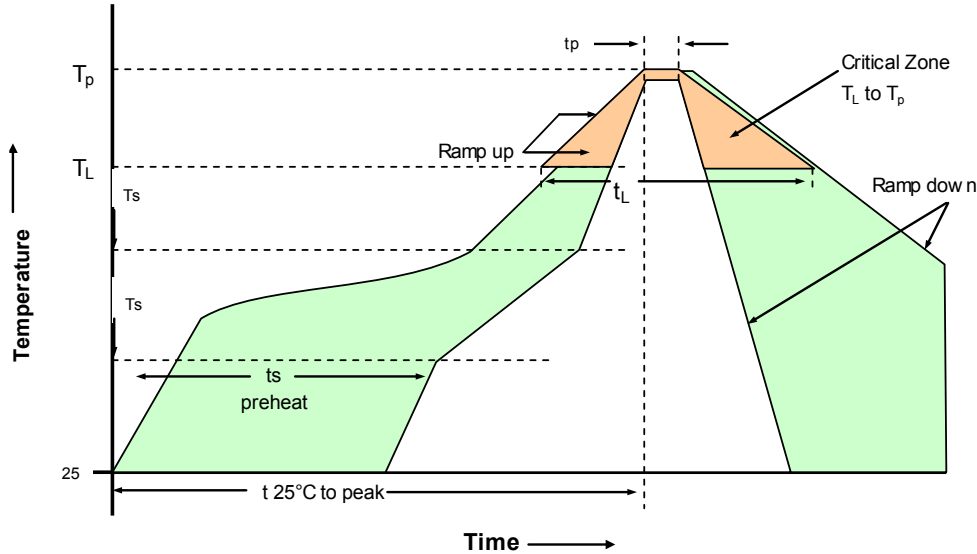

230°C Reflow Profile

Profile Feature	Sn-Pb Assembly	Profile Feature	Sn-Pb Assembly
Average ramp-up rate (TL to TP)	3°C/seconds max.	Time 25°C to Peak Temperature	4 minutes max.
Preheat - Temperature min T_{smin} - Temperature Min T_{smax} - Time (min to max) (ts)	135°C 155°C 60-90 seconds	Time maintained above - Temperature (TL) - Time (tL)	183°C 45-60 seconds
T_{smax} to TL -Ramp-up Rate	3°C/seconds max.		
Time maintained above - Temperature (TL) - Time (TL)	183°C 40-60 seconds	Time within 5°C of actual Peak Temperature (tp)	10-20 seconds max.
Peak Temperature (Tp)	max 230°C	Ramp-down Rate	6°C/seconds max.

Note: All temperatures refer to topside of the package, measured on the package body surface.

260°C Reflow Profile

Profile Feature	Pb-Free Assembly	Profile Feature	Pb-Free Assembly
Average ramp-up rate (TL to TP)	3°C/seconds max.	Time 25°C to Peak Temperature	8 minutes max.
Preheat - Temperature min T_{smin} - Temperature min T_{smax} - Time (min to max) (ts)	150°C 200°C 60-180 seconds	Time maintained above - Temperature (TL) - Time (tL)	217°C 60-150 seconds
T_{smax} to TL -Ramp-up Rate	3°C/second max.		
Time maintained above - Temperature (TL) - Time (TL)	217°C 60-150 seconds	Time within 5°C of actual Peak Temperature (tp)	20-40 seconds max.
Peak Temperature (Tp)	max 260°C	Ramp-down Rate	6°C/seconds max.

Note: All temperatures refer to topside of the package, measured on the package body surface.

Ordering Information

PX - 571 0 - D A E - F K A B - 10M000000

Product Family
PX: PXO

Package
8 x 9 mm (4 pin)

Configuration
1: Through Hole
2: Gull Wing
3: Inward L Type I (J-Lead Compatible)
4: Inward L Type II (M55310 Compatible)
5: Through Hole (with solder coated leads)
6: Gull Wing (with solder coated leads)
7: Inward L Type I (with solder coated leads)
8: Inward L Type II (with solder coated leads)

Supply Voltage
D: 5 Vdc ±5%
E: 3.3 Vdc ±5%
H: 2.5 Vdc ±5%
J: 1.8 Vdc ±5%

RF Output Code
A: HCMOS / ACMOS
B: TTL

Temperature Range
A: -55°C to +85°C
B: -55°C to +105°C
C: -55°C to +125°C
E: -40°C to +85°C
T: 0°C to +70°C

Frequency

Screening Option
B: MIL-PRF-55310 "B" level
X: No Screening

Enable Code
A: Enable Hi, Tristate
X: No Enable

Temperature Stability Code
(Reference to **Table: I**)

D: ±15ppm
F: ±25ppm
K: ±50ppm
P: ±80ppm
S: ±100ppm
Z: ±65PPM
X: Use with Overall Tolerance Code

Accuracy Code @ 25°C or Overall Temp Stability Code
(Reference to **Table: II**)

D: ±15ppm
F: ±25ppm
K: ±50ppm
P: ±80ppm
S: ±100PPM
Z: ±65PPM

Available Temperature Stability Code	
Temp Range	Temp Stability
A: -55°C to +85°C	K: ± 50ppm
B: -55°C to +105°C	Z ± 65ppm
	P ± 80ppm
C: -55°C to +125°C	S ± 100ppm
	F: ± 25ppm
E: -40°C to +85°C	K: ± 50ppm
	Z ± 65ppm
	P ± 80ppm
	S ± 100ppm
T: 0°C to +70°C	D: ± 15ppm
	F: ± 25ppm
	K: ± 50ppm
	Z ± 65ppm
	P ± 80ppm
	S ± 100ppm

Table: I

Available Overall Tolerance Code		
Temp Range	Overall Tolerance	Temp Stability
A: -55°C to +85°C	Z: ± 65ppm	X
B: -55°C to +105°C	P: ± 80ppm	X
	S: ± 100ppm	X
C: -55°C to +125°C	K: ± 50ppm	X
	Z: ± 65ppm	X
	P: ± 80ppm	X
	S: ± 100ppm	X
E: -40°C to +85°C	F: ± 25ppm	X
	K: ± 50ppm	X
	Z: ± 65ppm	X
	P: ± 80ppm	X
	S: ± 100ppm	X
	T: 0°C to +70°C	F: ± 25ppm
K: ± 50ppm		X
Z: ± 65ppm		X
P: ± 80ppm		X
S: ± 100ppm		X

Table: II

This Page Intentionally Left Blank

Notes:

1. Contact factory for improved stabilities or additional product options. Not all options and codes are available at all frequencies.
2. Unless other stated all values are valid after warm-up time and refer to typical conditions for supply voltage, frequency control voltage, load, temperature (25°C).
3. Phase noise degrades with increasing output frequency.
4. Subject to technical modification.
5. Contact factory for availability.

For Additional Information, Please Contact

USA:

Vectron International
267 Lowell Road, Unit 102
Hudson, NH 03051
Tel: 1.888.328.7661
Fax: 1.888.329.8328

Europe:

Vectron International
Landstrasse, D-74924
Neckarbischofsheim, Germany
Tel: +49 (0) 3328.4784.17
Fax: +49 (0) 3328.4784.30

Asia:

Vectron International
68 Yin Cheng Road (C), 22d Floor
One LuJiaZui
Pudong, Shanghai 200120, China
Tel: 86.21.6194.6886
Fax: 86.21.6194.6699

Disclaimer

Vectron International reserves the right to make changes to the product(s) and or information contained herein without notice. No liability is assumed as a result of their use or application. No rights under any patent accompany the sale of any such product(s) or information.