

AUGUST 2003

DESCRIPTION

The 78P2341JAT is a low-power, single channel DS3/E3/STS1 transceiver IC with integrated Jitter Attenuator (JAT). It includes clock recovery and transmitter pulse shaping functions for applications using 75-ohm coaxial cable at distances up to 1350 feet. These applications include DSLAMs, T1,3/E1,3 digital multiplexers, SONET Add/Drop multiplexers, PDH equipment, DS3 to Fiber optic and microwave modems, and ATM WAN access for routers and switches.

The receiver recovers clock and data from a B3ZS or HDB3 coded AMI signal. It can compensate for over 12dB of cable and 6dB of flat loss. The transmitter generates a signal that meets the standard pulse shape requirements. It has an integrated B3ZS/HDB3 ENDEC with a receive line code violation detector, a loop-back mode, a clock polarity selection mode, and the ability to receive a DSX3 monitor signal.

STANDARDS

- Jitter Tolerance: Telcordia GR-499-CORE [DS3] and GR-253-CORE [STS1], ITU-T G.823 [E3] and G.824 [DS3]
- Loss of Signal: ITU-T G.775
- Jitter Transfer: ETSI TBR-24 1997 [E3]; Telcordia GR-499-CORE [DS3] and GR-253-CORE [DS3/STS1]

FEATURES

- Transmit and receive interface for E3, DS3 and STS-1 applications
- Designed for use with 75 ohm coaxial cable up to 1350 ft long end-to-end or up to 900 ft long from a DS3 cross-connect
- Receive DS3-high and DSX3 monitor signals
- Local and Remote loopback
- Selectable B3ZS/HDB3 ENDEC with line code violation detector
- Standards-based LOS function
- Optional serial-port based mode selection and channel status monitoring
- Receiver AGC corrects for up to 6dB of flat loss
- Adaptive digital clock recovery (uses line-rate reference clock input)
- Receive output clock maintains nominal line-rate frequency at all times
- Fully integrated Jitter Attenuator (no external VCXO required) configurable for transmit or receive path
- Transmit line fault monitor
- Requires no external current-setting resistor or loop filter components
- Single 3.3V supply operation
- Available in 28-pin PLCC or 48-pin TQFP

BLOCK DIAGRAM

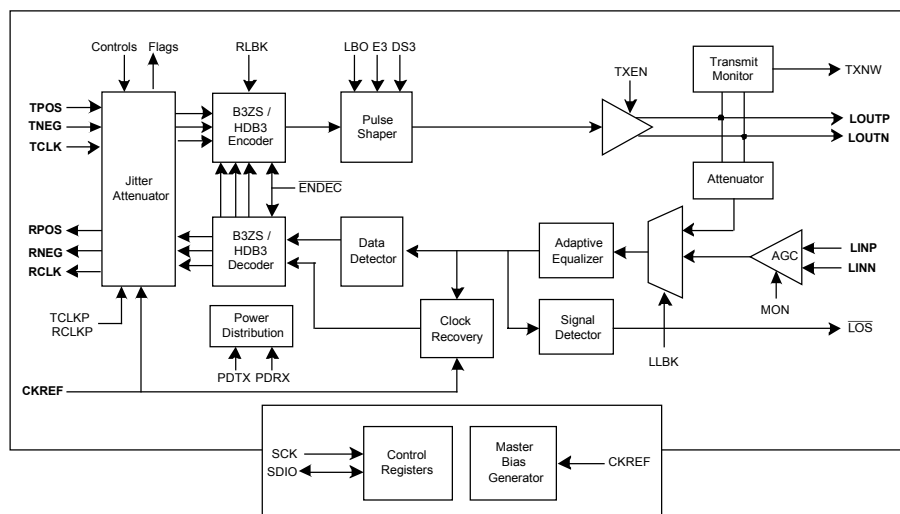

78P2341JAT

E3/DS3/STS-1 LIU

with Jitter Attenuator

FUNCTIONAL DESCRIPTION

The 78P2341JAT contains all the necessary transmit and receive circuitry for connection between E3, DS3, or STS-1 interfaces and Framer/Mapper ICs.

OPERATING RATE

The Master Control Register (MSCR) determines which mode the device operates in according to the table below. The MSL0 pin is also provided for mode selection in applications without a serial control interface. Upon power-up or reset, the state of the MSL0 pin is sensed and mapped into the DS3 and E3 register bits representing the appropriate mode of operation. After power-up/reset, the state of the MSL0 pin is ignored.

Standard	MSL0 pin	DS3 bit	E3 bit
E3	L	0	1
DS3	H	1	0
STS-1	Z	0	0
STS-1	Z	1	1

RECEIVER OPERATION

The receiver inputs LINP and LINN are either transformer-coupled or capacitor-coupled to the line signal. In applications where the highest performance and isolation are required, a 1:1 transformer is used in the receive path. In applications where isolation is provided elsewhere in the circuit, capacitor coupling can be used. The receiver inputs should be line terminated externally with a termination resistor.

The AMI signal first enters an AGC, which has a selectable gain range setting. In normal operation, the AGC can compensate for signals with up to 6dB of flat loss. When Receiver Monitor Mode is enabled, the AGC can compensate for a DSX3 monitor signal with 16 to 20 dB of flat loss. The signal then enters a high performance adaptive equalizer. The equalizer is designed to overcome inter-symbol interference caused by long cable lengths. Because the equalizer is adaptive, the circuit will work with all square-shaped signals such as DS3-high or 34.368 Mbit/s E3. The variable gain differential amplifier automatically controls the gain to maintain a constant voltage level output regardless of the input voltage level.

The jitter tolerance of 78P2341JAT meets the requirements of ITU-T G.823 for E3 rates; the requirements of ITU-T G.824, GR-499 (Cat I and II) for DS3 rates; and the requirements of GR-253 for STS1 rates.

When the Jitter Attenuator is disabled, the jitter transfer function meets the requirements of GR-499 for Category II DS3 interfaces.

When the Jitter Attenuator is enabled, the 78P2341JAT meets the requirements of GR-499 and GR-253 for all categories of DS3/STS1 equipment and the ETSI TBR-24 requirements for E3 rates. To check conformance with other standards, please refer to the JITTER ATTENUATOR TRANSFER FUNCTION section for more detailed info.

REFERENCE CLOCK

The clock recovery system employs a digital PLL, which uses a line-rate reference clock frequency. This reference frequency can be input to the CKREF pin or it can utilize the transmitter clock input TCLK when CKREF is left floating or pulled high.

RECEIVER MONITOR MODE

When the MON pin is high, 20dB of flat gain is applied to the incoming signal before it is fed to the receive equalizer. Alternately, the MON bit in the Mode Control Register can be used if the Register Control bit, REGEN, is enabled.

SIGNAL DETECT

When the received signal is below a minimum threshold, the LOS signal (bit) in the Status Monitor register is asserted. A time delay is provided before this output is active so that transient interruptions do not cause false indications. By default, the LOS signal is also used to trigger an interrupt on the $\overline{\text{LOS}}$ pin. Note that the error events that control the assertion of the $\overline{\text{LOS}}$ pin can be configured in the Interrupt Control Register (INTC).

Note: In DS3 or STS-1 mode, when LBO is not enabled, the transmitters have to be properly terminated to ensure reliable LOS detection. If a transmitter is not terminated, the resultant 2x signal is large enough to couple to the neighboring receivers through the ESD diodes, causing false Signal Detect indication.

78P2341JAT E3/DS3/STS-1 LIU with Jitter Attenuator

LOOPBACK MODES

The $\overline{\text{LPBK}}$ pin is used to activate common loopback modes as shown in the table below. The LLBK and RLBK bits in the Mode Control Register can also control these modes when the Register Control bit, REGEN, is enabled.

$\overline{\text{LPBK}}$ pin	Loopback Mode
L	Local (Analog) Loopback Same as LLBK = '1'
Z	Remote (Digital) Loopback Same as RLBK = '1'
H	Normal Operation Same as LLBK, RLBK = '0'

When in Local (Analog) Loopback, the transmit output signals, LOU_TP,N are internally routed to the receiver inputs. Any incoming signals on LINP,N will be ignored when in Local Loopback. For proper operation in this mode, the transmitter needs to be properly terminated with no hanging cables.

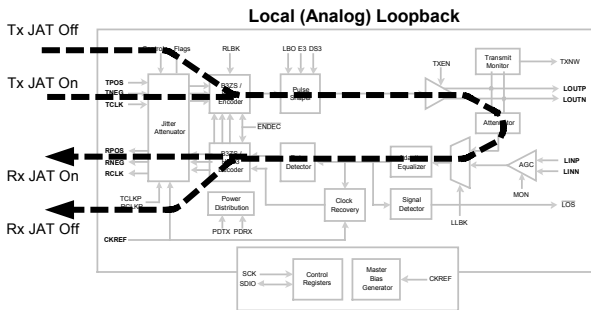

When in Remote (Digital) Loopback, the received signals and clock data, RPOS/RNEG/RCLK, are internally routed to the transmitter input signals. Any incoming data on TPOS, TNEG, or TCLK will be ignored when in Remote Loopback.

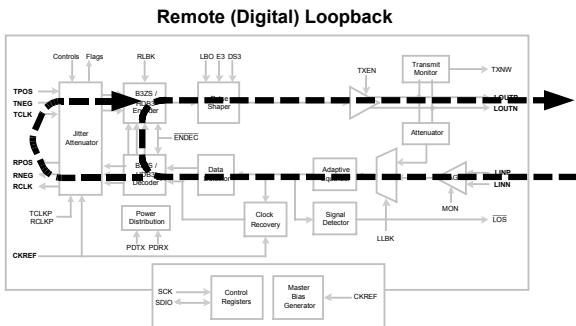

A third loopback mode is also available when using the serial control interface. Local (Digital) Loopback mode is controlled by the Jitter Attenuator Control Register and only passes through the Jitter Attenuator, bypassing all Analog blocks in the IC.

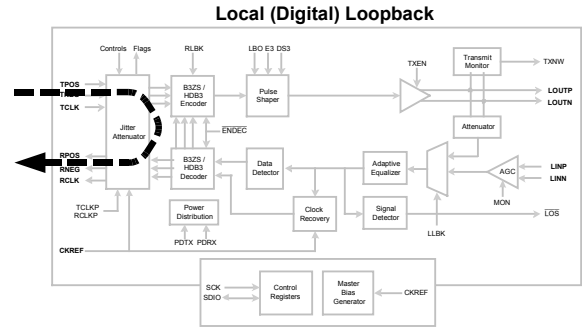

B3ZS/HDB3 ENDEC WITH LINE CODE VIOLATION DETECT

The 78P2341JAT includes a selectable B3ZS/HDB3 Encoder/Decoder (ENDEC). When the ENDEC pin is low, the ENDEC is selected and the decoder generates a composite NRZ logic data stream following the B3ZS (for DS3/STS-1) or HDB3 (for E3) substitution codes via the RPOS pin as shown below.

ENDEC	RPOS	RNEG
1	Positive AMI	Negative AMI
0	NRZ data	Receive Line Code Violation Indicator

The decoder also detects Receive Line Code Violations (RLCV) and outputs a pulse via the RNEG pin. Three different classes of line code violations are detected.

- Too many zeros: More than two (three) consecutive zeros in B3ZS (HDB3) mode.
- Not enough zeros between bipolar pulse (B) and bipolar violation pulse (V): (B,V) for B3ZS. (B,V) or (B,0,V) for HDB3.
- Code violation: Even number of bipolar pulses (B) detected between bipolar violation pulses (V).

78P2341JAT

E3/DS3/STS-1 LIU

with Jitter Attenuator

On the transmit side, when the $\overline{\text{ENDEC}}$ pin is low, NRZ input data is encoded to Positive and Negative logic data following the B3ZS (for DS3/STS-1) or HDB3 (for E3) substitution codes. The NRZ data is input to the TPOS pin as shown below.

$\overline{\text{ENDEC}}$	TPOS	TNEG
1	Positive AMI	Negative AMI
0	NRZ data	'Don't Care'

The $\overline{\text{ENDEC}}$ bit in the Mode Control Register can also control the ENDEC. The Register Control bit (REGEN) must be enabled if using the register settings to avoid conflict with external setting pins.

TRANSMITTER OPERATION

The transmitter accepts either NRZ coded data or positive and negative AMI signals and generates current pulses on the LOU TP and LOU TN pins. When properly connected to a 1:2CT center-tapped transformer, an AMI pulse is generated which can drive a 75 Ω coaxial cable.

When the recommended transformer is used and when DS3 mode is selected, the transmitted pulse shape at the end of the 75 Ω terminated cable of 0 to 450 feet will fit the DS3 template in ANSI T1.102-1993 and Telcordia GR-499-CORE standard documents. For STS-1 applications, the transmitted pulse for a short cable meets the requirements of Telcordia GR-253-CORE. For E3 applications, the transmitted pulse for a short cable meets the requirements of ITU-T G.703.

LINE BUILD-OUT

The Line Build-Out (LBO) function controls the transmit amplitude and pulse shape in DS3 and STS-1 modes. The selection of LBO depends on the amount of cable the transmitter is connected to. When less than 225 ft of cable is used, the LBO pin (or LBO bit) should be high. When 225ft or more cable is used, the LBO pin (or LBO bit) should be low.

LBO settings can be controlled either from pins or from register settings, depending on the status of the Register Control bit, REGEN. Note that LBO settings are ignored when in E3 mode.

TRANSMIT ENABLE

The TXEN pin controls the transmitter output. When low, the transmitter output is disabled. Alternately, the TXEN bit in the Mode Control register can control the transmitter if the Register Control bit is enabled.

TRANSMIT MONITOR

The transmit monitor function detects activity on the transmitter output at the LOU TP and LOU TN pins. When there is a transmitter fault, as in an open or short on the chip, the transformer, or the circuit board, the transmit signal amplitude will be altered. The transmit monitor detects the amplitude of the driven signal.

The TXOK pin goes low when the amplitude of the transmit signal is outside a valid amplitude range for longer than a specified duration. Alternately, the TXNW bit in the Status Monitor register can be used to monitor the transmit amplitude.

Note that the TXNW signal can also be used to trigger an event on the LOS pin. This is done by setting the TXER bit in the Interrupt Control Register (INTC).

JITTER ATTENUATOR

Jitter Attenuation function is provided on-chip. The Jitter Attenuator can be configured to be in the transmit or the receive path. When configured in the transmit path, the input clock at TCLK pin is passed through a very low bandwidth digital PLL. The corresponding transmit data is buffered into a FIFO and clocked out using the de-jittered output clock of the PLL. When configured in the receive path, the recovered clock is passed through the low bandwidth digital PLL, and the corresponding receive data is buffered into the FIFO and clocked out using the de-jittered clock.

The Jitter Attenuator can be configured by writing to the Jitter Attenuator Control Register (JACR) as follows:

JAEN bit	JASL bit	Jitter Attenuator Mode
0	X	Jitter Attenuator disabled
1	0	Jitter Attenuator configured to be in the receive path
1	1	Jitter Attenuator configured to be in the transmit path

78P2341JAT

E3/DS3/STS-1 LIU

with Jitter Attenuator

When serial interface control is not available, the TXEN and MON pins are provided for Jitter Attenuator mode selection. Upon power-up or reset, the states of the TXEN and MON pins are sensed and mapped into the JAEN and JASL register bits representing the appropriate mode of operation. After power-up/reset, the states of the TXEN and MON pins are ignored for JAT controls (Transmit Enable/Disable and Rx Monitor modes can still be controlled). The states of the TXEN and MON pins, and the corresponding Jitter Attenuator configuration are shown below.

TXEN pin	Jitter Attenuator Mode/Transmit Driver Mode
L	Jitter Attenuator disabled (upon reset) Disable transmit driver
Z	Jitter Attenuator enabled in transmit path (upon reset) Enable transmit driver
H	Jitter Attenuator disabled (upon reset) Enable transmit driver

MON pin	Jitter Attenuator Mode/Receive Monitor Mode
L	Jitter Attenuator disabled (upon reset) Disable monitor mode
Z	Jitter Attenuator enabled in receive path (upon reset) Disable monitor mode
H	Jitter Attenuator disabled (upon reset) Enable monitor mode

PLL Bandwidth

A PLL response with effectively one pole below 27 Hz is adequate to meet the ETSI TBR24 E3 standards. A PLL response with one pole below 40 Hz is adequate to meet the GR-499 (Cat I) DS3 standards. Either of the two bandwidths can be selected via register setting. In either high or low bandwidth mode, the PLL bandwidth is proportional to the data rate as follows:

Line Rate	JABW bit	PLL Bandwidth (Hz)
E3	0	13
	1	188
DS3	0	17
	1	245
STS1	0	20
	1	283

The default state of the JABW bit depends on which line-rate is selected through the MSL0 pin. If E3 or DS3 mode is selected, the default state is '0'. If STS1 mode is selected, the default state is '1'.

Elastic Store Depth

To optimize the trade-off between data latency and clock wander tolerance, the FIFO elastic store depth can be selected through the serial port by writing to the Jitter Attenuator Control Register (JACR) as follows:

ESP[1:0] bits	Elastic Store Depth
00	Pass-Through mode
01	16 UI
10	32 UI
11	64 UI (default)

The Elastic Store Depth selects the nominal FIFO read pointer address. The total or maximum elastic store depth is set to be twice as deep as the nominal pointer address. The circular buffer length is always twice as long as the nominal pointer address.

78P2341JAT

E3/DS3/STS-1 LIU

with Jitter Attenuator

RCLK/TCLK POLARITY REVERSAL

To simplify the interface with various framer circuitries, clock polarities can be set with the ICKP pin as described in the table below. Alternately, TCLK polarity can be internally inverted by setting the TCLKP bit, and RCLK polarity can be inverted by setting the RCLKP bit. Both bits are located in the Master Control Register (MSCR) and are only active when the Register Control Enable (REGEN) bit is enabled.

ICKP	RCLK/TCLK polarity
L	Update on falling edge of RCLK Sample on rising edge of TCLK
Z	Update on rising edge of RCLK Sample on falling edge of TCLK
H	Update on falling edge of RCLK Sample on falling edge of TCLK

POWER-DOWN FUNCTION

Power-down controls are provided to allow the transceiver to be shut off. Transmit and receive power-down can be set independently via the PDTX and PDRX bits in the Mode Control Register. The Serial Control Interface and Configuration Registers are not affected by power-down.

INTERNAL POWER-ON RESET

The 78P2341JAT includes on-chip Power-On Reset (POR) function to ensure the serial-port registers are initialized to known default states upon power-up. This reset signal also sets all state machines within the transceiver to nominal operational states. The internal reset signal is also brought out to the $\overline{\text{POR}}$ pin. This pin is a multi-function pin which allows for the following:

- 1) Override the internal $\overline{\text{POR}}$ signal by driving in an external active-low reset signal;
- 2) Monitor the state of the internal $\overline{\text{POR}}$ signal (for test and debug only);
- 3) Add external capacitor to delay the release of the internal power-on reset signal to allow the MSL0 pin to stabilize prior to release of reset (approximately 8 μ s per nF added).

The internal resistance of the $\overline{\text{POR}}$ pin is approximately 5k Ω . This pin is not available in the 28-pin PLCC version.

SERIAL CONTROL INTERFACE

The serial port controlled register allows a generic controller to interface with the 78P2341JAT. It is used for mode settings, diagnostics and test, and the retrieval of status and performance information.

The serial interface consists of two pins: Serial Clock (SCK) and Serial Data In and Out (SDIO). Serial Data In (SDI) and Serial Data Out (SDO) are connected together internally to simplify the operation. SCK is the clock input that times the data on SDIO. Data on SDI is latched in on the rising-edge of SCK, and data on SDO is clocked out using the falling edge of SCK.

SDI is used to insert mode, address, and register data into the chip. Address and Data information are input least significant bit (LSB) first. The mode and address bit assignment and register table are shown in the following section.

SDO is a tristate capable output. It is used to output register data during a read operation. SDO output is normally high impedance, and is enabled only during the duration when register data is being clocked out. Read data is clocked out significant bit (LSB) first.

The maximum clock frequency for register access is 20MHz, while the minimum is 5MHz. There must be at least 10us between clock bursts.

78P2341JAT E3/DS3/STS-1 LIU with Jitter Attenuator

REGISTER DESCRIPTION

REGISTER ADDRESSING

Address Bits	Bit 7	Bit 6	Bit 5	Bit 4	Bit 3	Bit 2	Bit 1	Bit 0
	Port Address				Sub-Address			Read/ Write
Assignment	PA[3]	PA[2]	PA[1]	PA[0]	SA[2]	SA[1]	SA[0]	R/W*

REGISTER TABLE

a) PA[3:0] = 0 : Global Registers

Sub Addr	Reg. Name	Description	Bit 7	Bit 6	Bit 5	Bit 4	Bit 3	Bit 2	Bit 1	Bit 0
0	MSCR (R/W)	Master Control	REGEN <0>	DS3 <X>	E3 <X>	ENDEC <0>	RCLKP <0>	TCLKP <0>	--	SRST <0>
1	INTC (R/W)	Interrupt Control	INPOL <0>	--	--	--	JAF LG <0>	JAER <0>	RXER <1>	TXER <1>
2	RSVD	Reserved	--	--	--	--	--	--	--	--
3	RSVD	Reserved	<0>	<0>	<0>	<0>	<0>	<0>	<0>	<0>
4	RSVD	Reserved	--	--	--	--	--	--	--	--
5	RSVD	Reserved	--	--	--	--	--	--	--	--
6	RSVD	Reserved	<0>	<0>	<0>	<0>	<0>	<0>	<0>	<0>
7	RSVD	Reserved	<0>	<0>	<0>	<0>	<0>	<0>	<0>	<0>

b) PA[3:0] = 1 : Specific Registers

Sub Addr	Reg. Name	Description	Bit 7	Bit 6	Bit 5	Bit 4	Bit 3	Bit 2	Bit 1	Bit 0
0	MDCR (R/W)	Mode Control	PDTX <0>	PDRX <0>	LBO <1>	--	LLBK <0>	RLBK <0>	MON <0>	TXEN <1>
1	STAT (R/O)	Status Monitor	FERR	FLIM1	FLIM2	SLIP	LOS	TXNW	SGHI	SGLO
2	RSVD	Reserved	--	<1>	<0>	<1>	<0>	<1>	<0>	<0>
3	JACR (R/W)	Jitter Attenuator Control	JAEN <X>	JASL <X>	JLBK <0>	<0>	ESP[1] <1>	ESP[0] <1>	<0>	JABW <X>
4	RSVD	Reserved	--	--	--	--	--	--	--	--
5	RSVD	Reserved	<0>	<0>	<0>	<0>	<0>	<0>	<0>	<0>
6	RSVD	Reserved	--	--	--	--	--	--	--	--
7	RSVD	Reserved	<0>	<0>	<0>	<0>	<0>	<0>	<0>	<0>

Note: Shaded registers in Register Table are reserved for TDK internal use only. Accessing reserved or undefined registers may cause undesirable operation.

78P2341JAT

E3/DS3/STS-1 LIU

with Jitter Attenuator

REGISTER DESCRIPTION (continued)

LEGEND

TYPE	DESCRIPTION	TYPE	DESCRIPTION
R/O	Read only	R/W	Read or Write

GLOBAL REGISTERS

ADDRESS 0-0: MASTER CONTROL REGISTER

BIT	NAME	TYPE	DFLT VALUE	DESCRIPTION
7	REGEN	R/W	0	Register Control Enable: 0 : Pin selection overrides register settings. 1 : Device is controlled via register set.
6	DS3	R/W	X	Line Speed Selection: Selects the line speed as well as the input clock frequency at the CKREF pin. [DS3 E3] = 00 : STS-1 (51.840MHz) 01 : E3 (34.368MHz) 10 : DS3 (44.736MHz) 11 : STS-1 (51.840MHz) NOTE: The default values of these register bits depend on the state of the MSL0 pin upon power-up or reset.
5	E3	R/W	X	
4	$\overline{\text{ENDEC}}$	R/W	0	Encoder/Decoder Disable: 0 : selects NRZ digital data interface 1 : selects AMI digital data interface NOTE: Relevant only when the REGEN bit is set. Otherwise, $\overline{\text{ENDEC}}$ pin selection prevails.
3	RCLKP	R/W	0	RCLK Polarity Selection: 0 : Receive Data clocked out on the falling-edge of RCLK 1 : Receive Data clocked out on the rising-edge of RCLK
2	TCLKP	R/W	0	TCLK Polarity Selection: 0 : Transmit Data clocked in on the rising-edge of TCLK 1 : Transmit Data clocked in on the falling-edge of TCLK
1	RSVD	R/O	X	Reserved
0	SRST	R/W	0	Register Soft-Reset: When this bit is set, all registers are reset to their default values. Also resets Jitter Attenuator to "centered" states. This register bit is self-clearing.

78P2341JAT
E3/DS3/STS-1 LIU
with Jitter Attenuator

REGISTER DESCRIPTION (continued)

ADDRESS 0-1: INTERRUPT CONTROL REGISTER

This register selects the events that would cause the $\overline{\text{LOS}}$ pin to be activated. User may set as many bits as required.

BIT	NAME	TYPE	DFLT VALUE	DESCRIPTION
7	INPOL	R/W	0	Interrupt Pin Polarity Selection: 0 : Interrupt output is active-low 1 : Interrupt output is active-high
6:4	RSVD	R/O	X	Reserved
3	JAFLG	R/W	0	Reserved for test only. Must be set to '0'.
2	JAER	R/W	0	Jitter Attenuator Error Event: When set, JAT FIFO overflow or underflow (as indicated by the FERR bit) will cause an interrupt to be flagged.
1	RXER	R/W	1	Receiver Error Event: When set, loss of receive signal (as indicated by the LOS bit) will cause an interrupt to be flagged.
0	TXER	R/W	0	Transmitter Error Event: When set, transmitter fault (as indicated by the TXNW bit) will cause an interrupt to be flagged.

78P2341JAT

E3/DS3/STS-1 LIU

with Jitter Attenuator

REGISTER DESCRIPTION (continued)

SPECIFIC REGISTERS

For PA[3:0] = 1 only. Accessing a register with port address greater than 1 constitutes an invalid command, and the read/write operation will be ignored.

ADDRESS 1-0: MODE CONTROL REGISTER

BIT	NAME	TYPE	DFLT VALUE	DESCRIPTION
7	PDTX	R/W	0	Transmitter Power-Down: 0 : Normal Operation 1 : Power-Down
6	PDRX	R/W	0	Receiver Power-Down: 0 : Normal Operation 1 : Power-Down
5	LBO	R/W	1	Transmitter Line Build-Out (DS3 and STS-1 only): 0 : \geq 225ft of cable attached to the cross-connect 1 : $<$ 225ft of cable attached to the cross-connect (Note this bit is inactive when REGEN bit is '0')
4	RSVD	R/W	0	Reserved
3	LLBK	R/W	0	Local (Analog) Loopback Mode Enable: 0 : Normal operation 1 : Loops LOUTP and LOUTN back onto LINP and LINN (Note this bit is inactive when REGEN bit is '0')
2	RLBK	R/W	0	Remote (Digital) Loopback Enable: 0 : Normal Operation 1 : Loops RCLK, RPOS, and RNEG back onto TCLK, TPOS, and TNEG (Note this bit is inactive when REGEN bit is '0')
1	MON	R/W	0	Monitor Mode Enable: Used for reception of split-off signals that are flat-attenuated by at least 16dB but no more than 20dB. 0 : Disable 1 : Enable (Note this bit is inactive when REGEN bit is '0')
0	TXEN	R/W	1	Transmitter Output Enable: 0 : Transmit driver is disabled 1 : Normal Operation (Note this bit is inactive when REGEN bit is '0')

78P2341JAT
E3/DS3/STS-1 LIU
with Jitter Attenuator

REGISTER DESCRIPTION (continued)

ADDRESS 1-1: STATUS MONITOR REGISTER

BIT	NAME	TYPE	DFLT VALUE	DESCRIPTION
7	FERR	R/O	X	Jitter Attenuator FIFO Error Flag: This bit is set whenever a FIFO overflow or underflow occurred. It is reset after a read operation to this register. 0 : Proper Operation 1 : FIFO Overflow/Underflow
6:4	JAF[2:0]	R/O	X	Jitter Attenuator Monitor Flags: Used for internal test only. Ignore during normal operation.
3	LOS	R/O	X	Loss-of-Signal Indication: 0 : Signal Detector detecting a valid receive input signal 1 : Standards-based Loss-of-Signal indication <u>Note:</u> RPOSx and RNEGx are forced low when LOS='1' ; RCLK will continue to output a line rate clock
2	TXNW	R/O	X	Transmitter Not-Working Indication: 0 : Transmitter OK 1 : Transmitter not working
1	SGHI	R/O	X	Signal High Indication: Used for internal test only. Ignore during normal operation
0	SGLO	R/O	X	Signal Low Indication: 0 : Receive signal level OK 1 : Receive signal level too low / Loss of signal

78P2341JAT

E3/DS3/STS-1 LIU

with Jitter Attenuator

REGISTER DESCRIPTION (continued)

ADDRESS 1-3: JITTER ATTENUATOR CONTROL REGISTER

BIT	NAME	TYPE	DFLT VALUE	DESCRIPTION
7	JAEN	R/W	X	Jitter Attenuator Enable: 0 : Disables jitter attenuation function 1 : Enables jitter attenuation function Note: The default value of this register bit depends on the state of the TXEN and MON pins upon power up or a reset.
6	JASL	R/W	X	Jitter Attenuation Selection: 0 : Jitter Attenuator on the receive path 1 : Jitter Attenuator on the transmit path Note: The default value of this register bit depends on the state of the TXEN and MON pins upon power up or a reset.
5	JLBK	R/W	0	Jitter Attenuator Local Loopback Enable: 0 : Normal Operation 1 : TCLKx, TPOSx, TNEGx connected to JAT input and RCLKx, RPOSx, RNEGx connected to JAT output Note: If both RLBK and JLBK bits are set, RLBK mode takes priority.
4	RSVD	R/W	0	Reserved. Must be set to zero.
3:2	ESP [1:0]	R/W	11	FIFO Elastic Store Pointer Selection: 00 : Pass-through 01 : 8 UI 10 : 16 UI 11 : 32 UI
1	RSVD	R/W	0	Reserved. Must be set to zero.
0	JABW	R/W	X	Jitter Attenuator Bandwidth Selection: 0 : Low bandwidth 1 : High bandwidth (see JAT Bandwidth Selection Table on page 5) Note that the default value of this register bit depends on the power-up state of the MSL0 pin. If the state of the MSL0 pin selects E3 or DS3 mode, the default value of JABW is '0'. If the state of the MSL0 pin selects STS1 mode, the default value of JABW is '1'.

78P2341JAT
E3/DS3/STS-1 LIU
with Jitter Attenuator

PIN DESCRIPTION

LEGEND

TYPE	DESCRIPTION	TYPE	DESCRIPTION
A	Analog Pin	CIS	CMOS Schmitt Trigger Input
CI	CMOS Digital Input	CO	CMOS Digital Output
CIU	CMOS Digital Input w/ Pull-up	COZ	CMOS Tristate Digital Output
CID	CMOS Digital Input w/ Pull-down	S	Supply

TRANSMITTER PINS

NAME	PIN TQFP	PIN PLCC	TYPE	DESCRIPTION
TPOS	16	14	CI	<p>Transmit Positive Data/Transmit NRZ:</p> <p>When $\overline{\text{ENDEC}} = '1'$, a logic one on this pin generates a positive AMI pulse on the coax. This pin should not be high at the same time that corresponding TNEG is high.</p> <p>When $\overline{\text{ENDEC}} = '0'$, data on this pin is encoded and converted into positive and negative AMI pulses.</p>
TNEG	17	15	CI	<p>Transmit Negative Data:</p> <p>When $\overline{\text{ENDEC}}$ bit = '1', a logic one on this pin generates a negative AMI pulse on the coax. This pin should not be high at the same time that corresponding TPOS is high.</p> <p>When $\overline{\text{ENDEC}}$ bit = '0', this pin is ignored.</p>
TCLK	18	16	CIS	<p>Transmitter Clock Input:</p> <p>This clock signal is used to latch the respective TPOS and TNEG signals into the 78P2341JAT. The frequency should correspond to the line-rate frequency as follows:</p> <p style="padding-left: 40px;">E3 : 34.368 MHz DS3: 44.736 MHz STS-1: 51.840 MHz</p> <p>If CKREF pin pulled high or left floating, TCLK is also used as the reference clock for the 78P2341JAT.</p>
LOUTP LOUTN	9 11	9 11	A	<p>Line Out:</p> <p>Differential AMI Outputs. Requires a 1:2CT center-tapped transformer and a shunt termination resistor. See APPLICATION INFORMATION section for more info.</p>

78P2341JAT

E3/DS3/STS-1 LIU

with Jitter Attenuator

PIN DESCRIPTION (continued)

RECEIVER PINS

NAME	PIN TQFP	PIN PLCC	TYPE	DESCRIPTION
CKREF	26	19	CIU	<p>Reference Clock Input:</p> <p>This clock should be from a clean source (± 20 ppm) and represents the line-rate frequency as follows:</p> <p>E3 : 34.368 MHz DS3: 44.736 MHz STS-1: 51.840 MHz</p> <p>Tying this pin high or leaving it floating forces the 78P2341JAT to use the clock applied to the transmitter clock input (TCLK) as the reference source.</p>
RCLK	33	23	CO	<p>Receive Clock: Recovered receive clock.</p> <p>Note: When Loss of Signal (LOS) occurs, RCLK will output the reference clock applied at CKREF (or TCLK if CKREF is pulled high or left floating).</p>
RNEG	34	24	CO	<p>Receive Negative Data:</p> <p>When $\overline{\text{ENDEC}} = '1'$, this pin indicates reception of a negative AMI pulse on the coax.</p> <p>When $\overline{\text{ENDEC}} = '0'$, this pin outputs a one when a receive line code violation is detected.</p>
RPOS	35	25	CO	<p>Receive Positive Data/NRZ Data:</p> <p>When $\overline{\text{ENDEC}} = '1'$, this pin indicates reception of a positive AMI pulse on the coax cable.</p> <p>When $\overline{\text{ENDEC}} = '0'$, it outputs decoded NRZ data.</p>
LINP LINN	42 44	1 3	A	<p>Line In:</p> <p>Differential AMI Inputs. Should be 1:1 transformer-coupled and terminated with a shunt resistor. See APPLICATION INFORMATION section for more info.</p>

78P2341JAT
E3/DS3/STS-1 LIU
with Jitter Attenuator

PIN DESCRIPTION (continued)

CONTROL AND STATUS PINS

NAME	PIN TQFP	PIN PLCC	TYPE	DESCRIPTION
MSLO	15	13	A	Data-Rate Mode Selection: Low = E3 mode High = DS3 mode Float = STS-1 mode Note: This pin is only sensed upon power up or a reset.
MON	28	21	A	Receive Monitor and Jitter Attenuator Mode Selection: Low = Disable monitor mode and disable RX jitter attenuation High = Enable monitor mode and disable RX jitter attenuation Float = disable monitor mode and enable RX jitter attenuation (Note this pin is inactive when REGEN register bit is '1')
$\overline{\text{POR}}$	12	XX	A	Power-On Reset: See Power-On Reset description on use of this pin.
LBO	13	12	CID	Line Build-Out: Logic low used with 225ft or more of cable. Logic high used with less than 225ft of cable. (Note this pin is inactive when REGEN register bit is '1')
$\overline{\text{LPBK}}$	40	28	A	Loopback Enable: Low = Local Loopback. Transmitter looped back to Receiver High = Normal Operation Float = Remote Loopback. Receiver looped back to Transmitter (Note this pin is inactive when REGEN register bit is '1')
TXEN	22	18	A	Transmit Tri-state and Jitter Attenuator Mode Selection: Low = Disable transmit output driver and disable TX jitter attenuation High = Enable transmit output driver and disable TX jitter attenuation Float = Enable transmit output driver and enable TX jitter attenuation
ICKP	10	10	A	Invert Clock Polarity Selection: Low=Update on falling edge of RCLK, Sample on rising edge of TCLK High=Update on falling edge of RCLK, Sample on falling edge of TCLK Float=Update on rising edge of RCLK, Sample on falling edge of TCLK (Note this pin is inactive when REGEN register bit is '1')
$\overline{\text{ENDEC}}$	27	20	A	ENDEC enable (active-low): When low, activates B3ZS/HDB3 ENDEC on receiver and transmitter logic signals. (Note this pin is inactive when REGEN register bit is '1')
JAERR	36	XX	CO	Jitter Attenuator Error: Logic high indicates FIFO over/underflow. Same as the FERR bit in the Status Monitor Register.
$\overline{\text{LOS}}$	39	27	A	Loss of Signal (active low): When low, indicates the receive signal (LINP,N) is below the threshold level for 128 periods (default setting). Can be configured to represent any combination of LOS, TXNW, and FERR error events through the Interrupt Control Register
TXOK	30	XX	CO	Transmitter OK: Logic high when transmitter amplitude within valid ranges. Inversed logic of the TXNW bit in the Status Monitor register.

78P2341JAT

E3/DS3/STS-1 LIU

with Jitter Attenuator

PIN DESCRIPTION (continued)

SERIAL-PORT PINS

NAME	PIN TQFP	PIN PLCC	TYPE	DESCRIPTION
SCK	47	4	CIS	Serial Clock: Controls the timing of SDI and SDO.
SDIO	2	5	CI COZ	Serial Data Input and Output: Inputs mode and address information. Also inputs register data during a Write operation. Both address and data are input least significant bit first. Outputs register information during a Read operation. Data is output least significant bit first

POWER AND GROUND PINS

It is recommended that all supply pins be connected to a single power supply plane and all ground pins be connected to a single ground plane.

NAME	PIN TQFP	PIN PLCC	TYPE	DESCRIPTION
VCC	5, 6, 20, 21	7, 17	S	Analog Power Supply
GND	3, 4, 7, 8, 43, 45, 46	2, 6, 8	S	Analog Ground
VCCD	37, 38	26	S	Digital Power Supply
GNDD	31, 32	22	S	Digital Ground

78P2341JAT
E3/DS3/STS-1 LIU
with Jitter Attenuator

ELECTRICAL SPECIFICATIONS

ABSOLUTE MAXIMUM RATINGS

Operation beyond these limits may permanently damage the device.

PARAMETER	RATING
Supply Voltage (VCC/VCCD)	-0.5 to 4.0 V
Storage Temperature	-65 to 150° C
Junction Temperature	-40 to 125 °C
Pin Voltage (LOUTP, LOUTN)	VCC + 1.5 VDC
Pin Voltage (all other pins)	-0.3 to (VCC+0.6) VDC
Pin Current	±100 mA

RECOMMENDED OPERATING CONDITIONS

Unless otherwise noted all specifications are valid over these temperatures and supply voltage ranges.

PARAMETER	RATING
DC Voltage Supply (VCC/VCCD)	3.0 to 3.6 V
Ambient Operating Temperature	-40 to 85°C

DC CHARACTERISTICS:

PARAMETER	SYMBOL	CONDITIONS	MIN	NOM	MAX	UNIT
Supply Current	I _{dd}	VCC = 3.3V DS3 mode Max. cable length JAT Enabled: JAT Disabled:		99 83		mA mA
Supply Current	I _{ddr}	VCC = 3.3V Transmitter disabled DS3 mode Max. cable length JAT Enabled: JAT Disabled:		46 30		mA mA

78P2341JAT

E3/DS3/STS-1 LIU

with Jitter Attenuator

ELECTRICAL SPECIFICATIONS (continued)

ANALOG PINS CHARACTERISTICS:

The following table is provided for informative purpose only. Not tested in production.

PARAMETER	SYMBOL	CONDITIONS	MIN	NOM	MAX	UNIT
LINP and LINN Common-Mode Bias Voltage	Vblin	Ground reference	1.9		2.6	V
LINP and LINN Differential Input Impedance	Rilin			10		k Ω
\overline{POR} Input Impedance	Ripor			5		k Ω

DIGITAL I/O CHARACTERISTICS:

Pins of type CI, CIU, CID:

PARAMETER	SYMBOL	CONDITIONS	MIN	NOM	MAX	UNIT
Input Voltage Low	Vil				0.8	V
Input Voltage High	Vih		2.0			V
Input Current	Iil, Iih		-1		1	μ A
Pull-up Resistance	Rpu	Type CIU only	53	70	113	k Ω
Pull-down Resistance	Rpd	Type CID only	43	58	118	k Ω
Input Capacitance	Cin			10		pF

Pins of type CIS:

PARAMETER	SYMBOL	CONDITIONS	MIN	NOM	MAX	UNIT
Low-to-High Threshold	Vt+		1.45		1.55	V
High-to-Low Threshold	Vt-		0.85		0.95	V
Input Current	Iil, Iih		-1		1	μ A
Input Capacitance	Cin			10		pF

Pins of type CO and COZ:

PARAMETER	SYMBOL	CONDITIONS	MIN	NOM	MAX	UNIT
Output Voltage Low	Vol	Iol = 8mA			0.4	V
Output Voltage High	Voh	Ioh = -8mA	2.4			V
Output Transition Time	Tt	CL = 20pF; (20-80%)			3	ns
Tristate Output Leakage Current	Iz	Type COZ only	-1		1	μ A

78P2341JAT E3/DS3/STS-1 LIU with Jitter Attenuator

ELECTRICAL SPECIFICATIONS (continued)

SERIAL-PORT TIMING CHARACTERISTICS:

PARAMETER	SYMBOL	CONDITION	MIN	TYP	MAX	UNIT
SDIO to SCK setup time	t_{su}		2			ns
SDIO to SCK hold time	t_h		2			ns
SCK to SDIO propagation delay	t_{prop}				3	ns

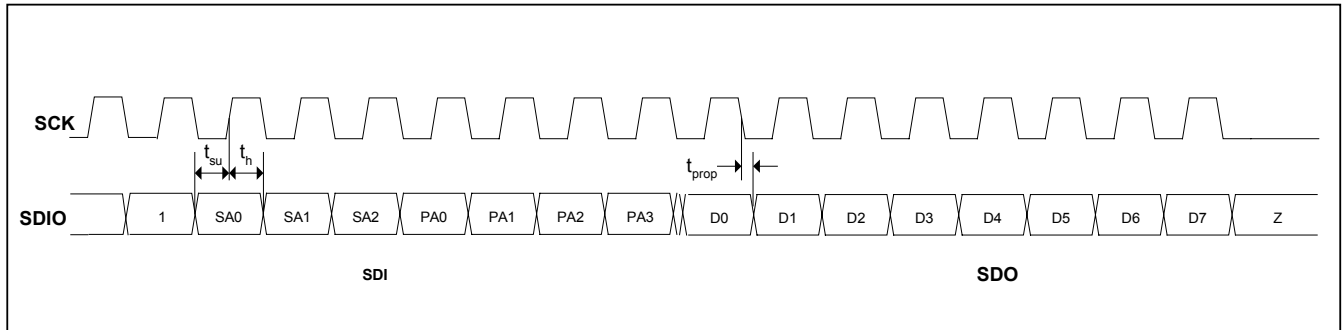

Read Operation

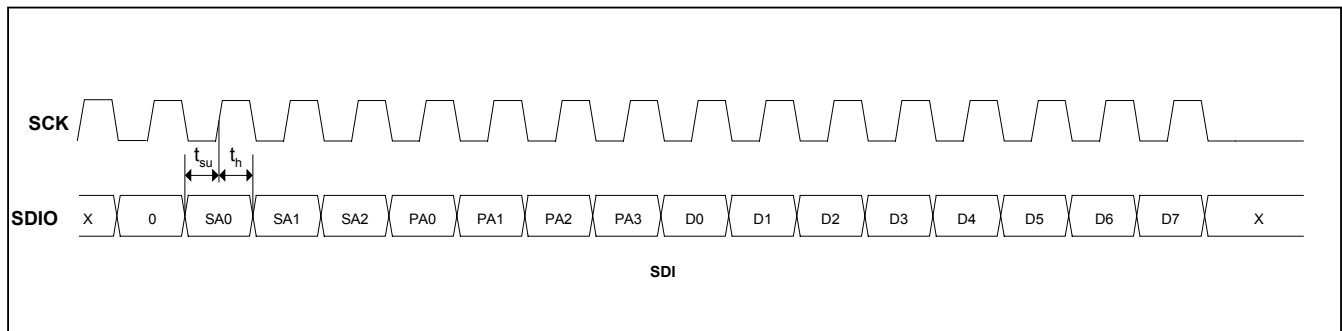

Write Operation

78P2341JAT

E3/DS3/STS-1 LIU

with Jitter Attenuator

ELECTRICAL SPECIFICATIONS (continued)

TRANSMITTER TIMING CHARACTERISTICS:

PARAMETER	SYMBOL	CONDITIONS	MIN	NOM	MAX	UNIT
Clock Duty Cycle	TTCF/TTC		40		60	%
Transition Time	TTCT		1		5	ns
Setup Time	TTDPS		2.5			ns
Hold Time	TTDPH		2.5			ns

TIMING DIAGRAM: Transmitter Waveforms (E3/DS3/STS-1)

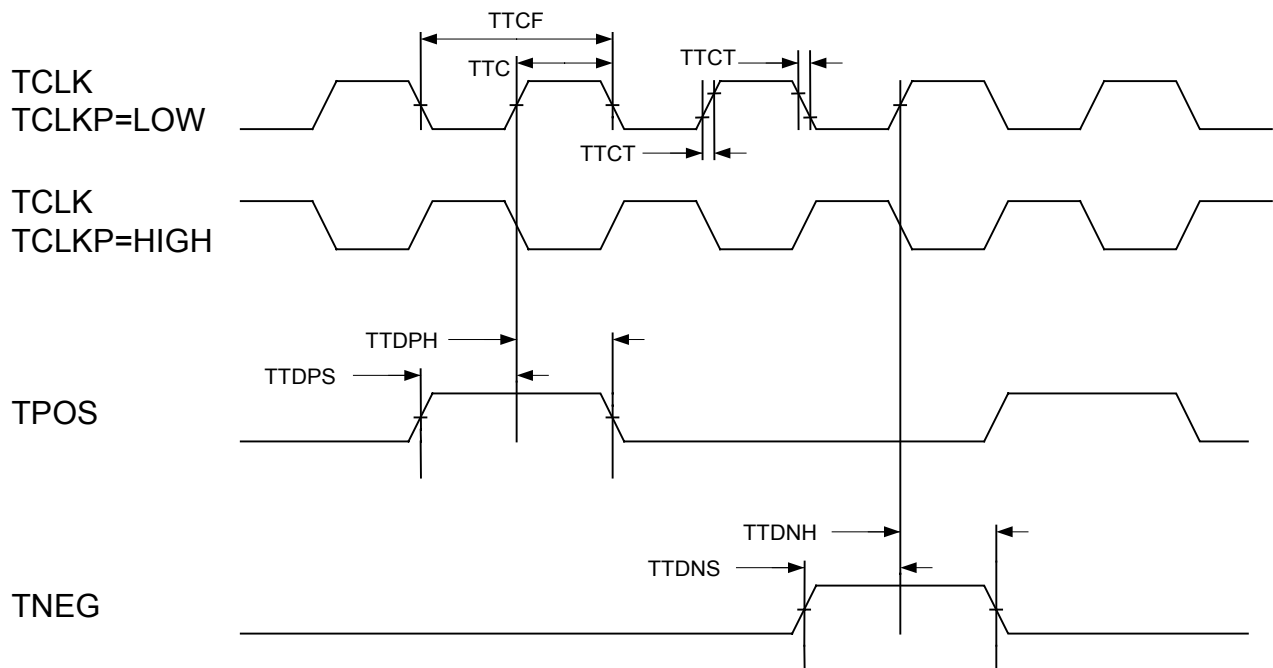

78P2341JAT E3/DS3/STS-1 LIU with Jitter Attenuator

ELECTRICAL SPECIFICATIONS (continued)

RECEIVER TIMING CHARACTERISTICS:

PARAMETER	SYMBOL	CONDITIONS	MIN	NOM	MAX	UNIT
CKREF Duty Cycle	--		40		60	%
CKREF Frequency Stability	--	w.r.t. line-rate frequency	-20		+20	ppm
Transition Time	TRCT		1		5	ns
RCLK Duty Cycle	TRCF/TRC		40		60	%
Data Setup Time	TRDPS		7			ns
Data Hold Time	TRDPH		7			ns

TIMING DIAGRAM: Receive Waveforms (E3/DS3/STS-1)

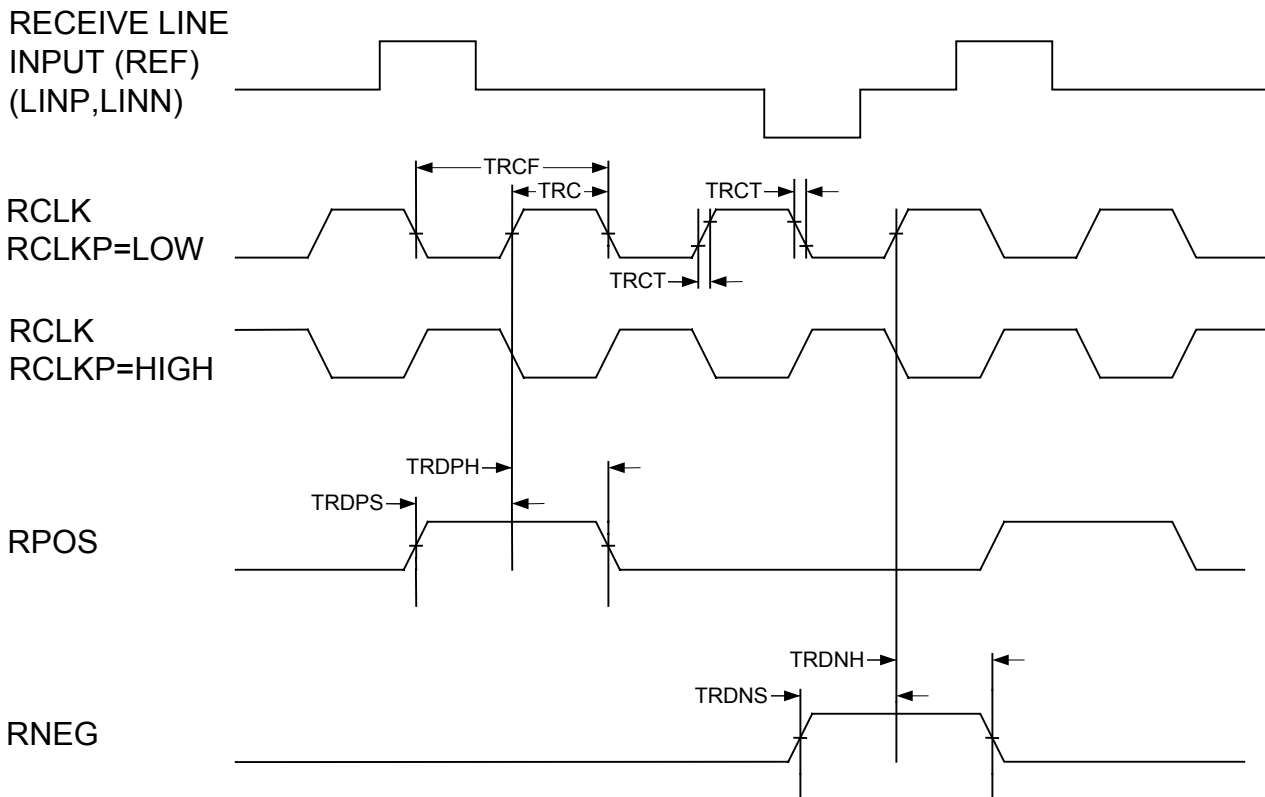

78P2341JAT

E3/DS3/STS-1 LIU

with Jitter Attenuator

ELECTRICAL SPECIFICATIONS (continued)

DS3 TRANSMITTER

PARAMETER	CONDITION	MIN	TYP	MAX	UNIT
Transmitter Amplitude	Measured at LOUDP/LOUTN pins w/ 37.5Ω load and LBO pin held high.	700	800	850	mVpk
Transmitter Amplitude Mismatch	Ratio of amplitudes of positive and negative pulses measured at pulse peaks.	0.9		1.1	
Transmitter Power at 22.368 MHz	All ones pattern, 3kHz bandwidth	-1.8		+5.7	dBm
Harmonic Power at 44.736 MHz	All ones pattern Power below fundamental at 22.368MHz			-20	dBm

STS-1 TRANSMITTER

PARAMETER	CONDITION	MIN	TYP	MAX	UNIT
Transmitter Amplitude	Measured at LOUDP/LOUTN pins w/ 37.5Ω effective load and LBO pin held high.	700	825	950	mVpk
Transmitter Amplitude Mismatch	Ratio of amplitudes of positive and negative pulses measured at pulse peaks.	0.9		1.1	
Transmitter Power	PRBS15 pattern band-limited to 207.36MHz.	-2.7		+4.7	dBm

E3 – TRANSMITTER

PARAMETER	CONDITION (see timing diagram)	MIN	TYP	MAX	UNIT
Transmitter Amplitude	Measured at LOUDP/LOUTN pins w/ 37.5Ω load.	900	1000	1100	mVpk
Transmitter Amplitude Mismatch	Ratio of amplitudes of positive and negative pulses measured at pulse centers	0.95		1.05	
Transmitter Pulsewidth Mismatch	Ratio of widths of positive and negative pulses measured at pulse half amplitude	0.95		1.05	
Transmitter Pulsewidth	Measured at LOUDP/LOUTN pins		14.8		ns

78P2341JAT
E3/DS3/STS-1 LIU
with Jitter Attenuator

ELECTRICAL SPECIFICATIONS (continued)

E3 TRANSMIT PULSE TEMPLATE

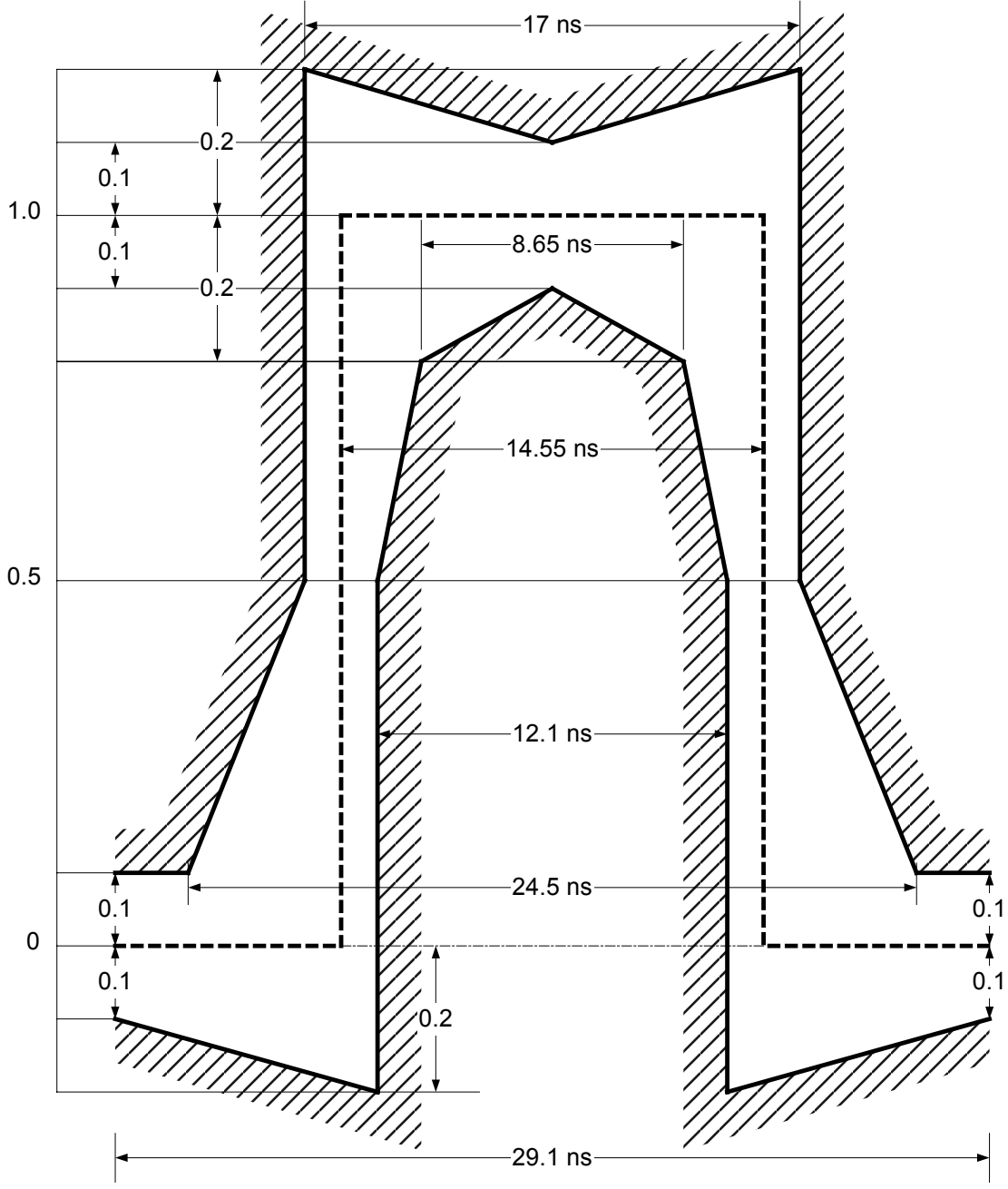

78P2341JAT

E3/DS3/STS-1 LIU

with Jitter Attenuator

ELECTRICAL SPECIFICATIONS (continued)

DS3 TRANSMIT PULSE TEMPLATE

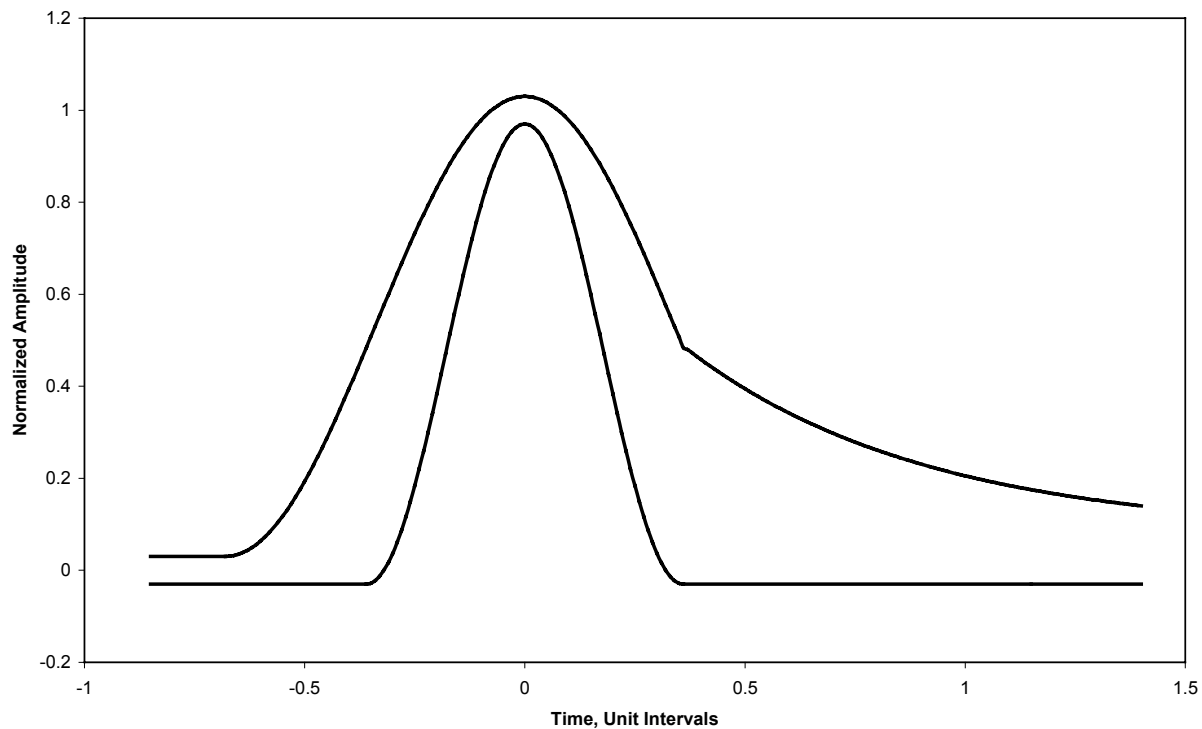

Time axis range (UI)	Normalized amplitude equation
UPPER CURVE	
$-0.85 \leq T \leq -0.68$	0.03
$-0.68 \leq T \leq 0.36$	$0.03 + 0.5\{1 + \sin[(\pi/2)(1 + T/0.34)]\}$
$0.36 \leq T \leq 1.4$	$0.08 + 0.407 e^{-1.84(T-0.36)}$
LOWER CURVE	
$-0.85 \leq T \leq -0.36$	-0.03
$-0.36 \leq T \leq 0.36$	$-0.03 + 0.5\{1 + \sin[(\pi/2)(1 + T/0.18)]\}$
$0.36 \leq T \leq 1.4$	-0.03

ELECTRICAL SPECIFICATIONS (continued)

STS-1 TRANSMIT PULSE TEMPLATE

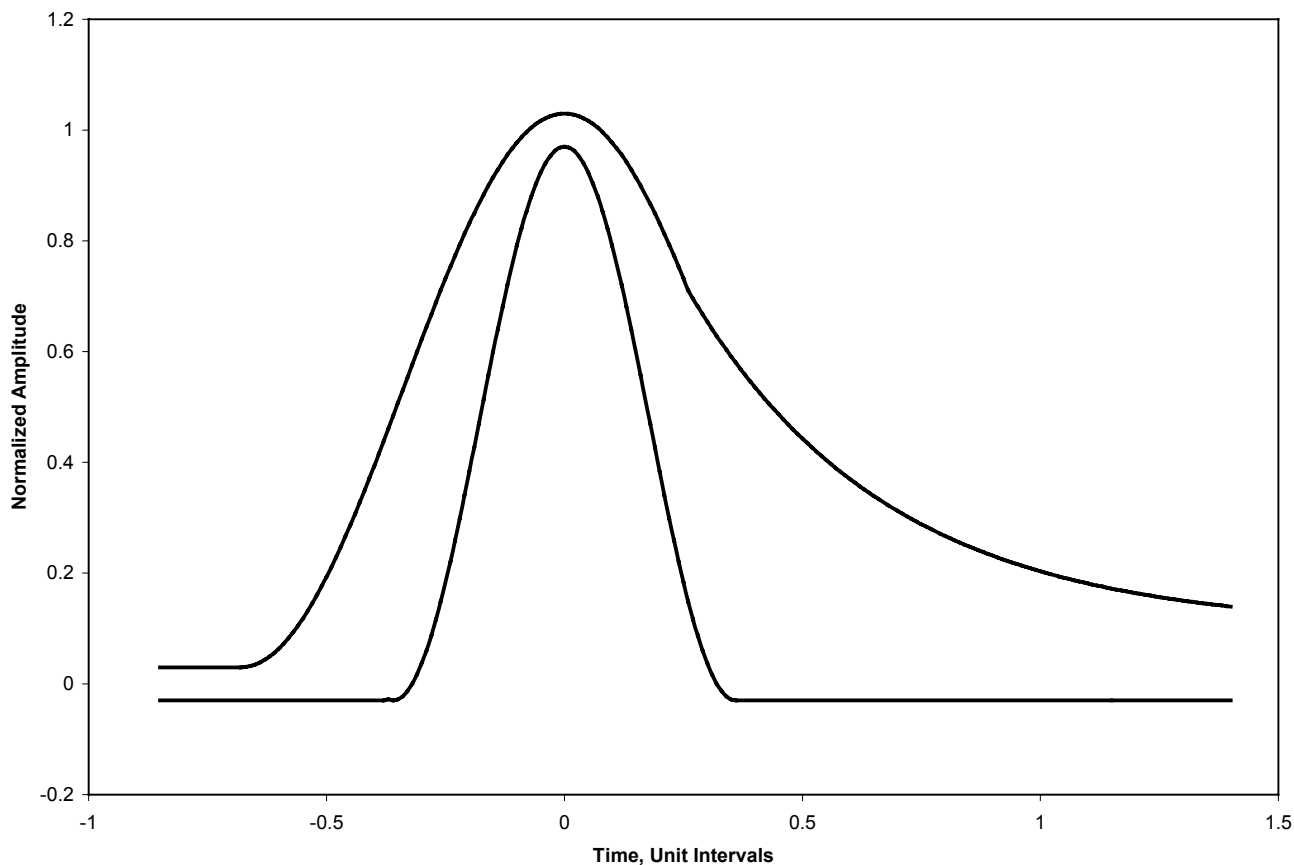

STS-1 (Transmit template specs)

Time axis range (T)	Normalized amplitude equation (A)
UPPER CURVE	
$-0.85 \leq T \leq -0.68$	0.03
$-0.68 \leq T \leq 0.26$	$0.03 + 0.5\{1 + \sin[(\pi/2)(1 + T/0.34)]\}$
$0.26 \leq T \leq 1.4$	$0.1 + 0.61 e^{-2.4(T-0.26)}$
LOWER CURVE	
$-0.85 \leq T \leq -0.38$	-0.03
$-0.38 \leq T \leq 0.36$	$-0.03 + 0.5\{1 + \sin[(\pi/2)(1 + T/0.18)]\}$
$0.36 \leq T \leq 1.4$	-0.03

78P2341JAT

E3/DS3/STS-1 LIU

with Jitter Attenuator

ELECTRICAL SPECIFICATIONS (continued)

TRANSMITTER OUTPUT JITTER

The transmit jitter specification ensures compliance with ITU-T G.823 and G.824, Telcordia GR-499 CORE(I) and GR-253-CORE, and ANSI T1.102-1993 for all supported rates. Transmit output jitter is guaranteed only if a clean SONET quality transmit clock source is used.

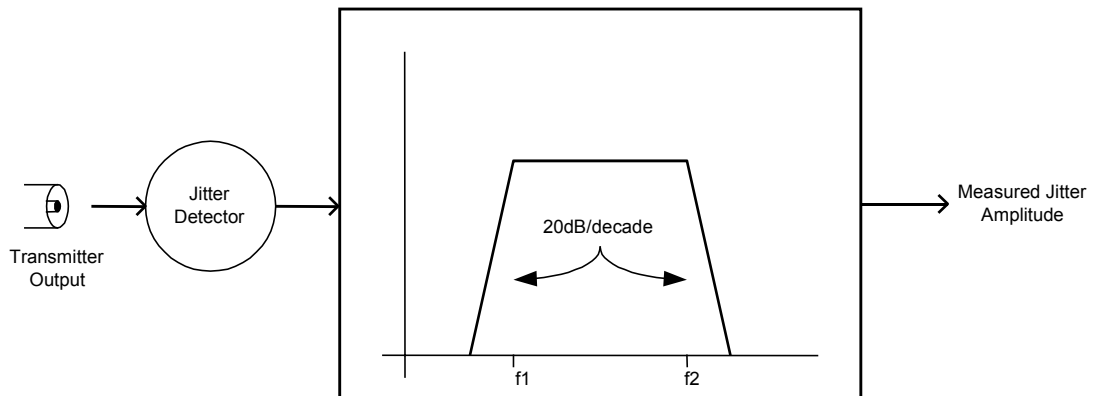

PARAMETER	CONDITION	MIN	NOM	MAX	UNIT
Transmitter Output Jitter	10 Hz to 800 kHz			0.15	UIpp
	10 kHz to 800 kHz			0.08	UIpp

Note: Filters defined by standards are used for all testing

78P2341JAT E3/DS3/STS-1 LIU with Jitter Attenuator

ELECTRICAL SPECIFICATIONS (continued)

TRANSMIT MONITOR

The transmit monitor function looks at the signals on the LOUTP and LOUTN pins and checks for the existence of a valid signal. The monitor detects the peak of the transmitted signal at the LOUTP and LOUTN pins and checks that it is between V_{UNDER} and V_{OVER} at all times. If the peak level is within the voltage threshold window, the TXOK signal is high (TXNW bit is low). If the peak level falls outside of the threshold limits for more than approximately 32 bit times, the TXOK signal goes low (TXNW bit goes high).

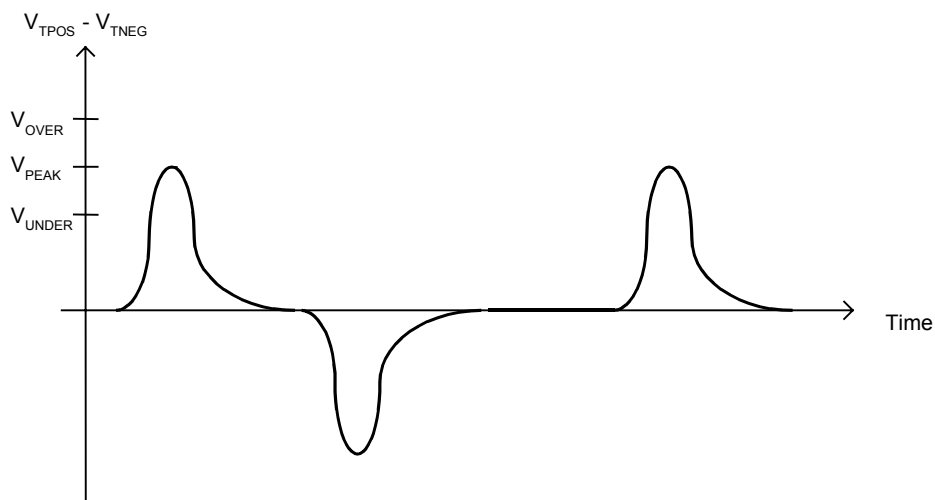

PARAMETER	CONDITION	MIN	TYP	MAX	UNIT
V_{UNDER}	DS3 mode with LBO=1 STS-1 mode		320		mVpk
V_{UNDER}	E3 mode DS3 mode with LBO=0		400		mVpk
V_{OVER}	DS3 mode with LBO=1 STS-1 mode		1280		mVpk
V_{OVER}	E3 mode DS3 mode with LBO=0		1600		mVpk

78P2341JAT

E3/DS3/STS-1 LIU

with Jitter Attenuator

ELECTRICAL SPECIFICATIONS (continued)

DS3/STS-1 RECEIVER (Transformer-coupled)

PARAMETER	CONDITION	MIN	TYP	MAX	UNIT
Peak Differential Input Amplitude, LINPx and LINNx	MON=0. Signal at DSX is 360-850 mVpk. See Notes 2, 3	90		850	mVpk
	MON=1	25		80	mVpk
	MON=0. DS3-HIGH	90		1200	mVpk
Flat-loss Tolerance	MON=0. All valid cable lengths.	0		6	dB
Receive Clock Jitter	DS3 mode with 10 Hz – 400 kHz				
	a) Normal receive mode b) Remote loopback mode			0.1 0.06	U _{Ipp} U _{Ipp}
Interfering Tone Tolerance (see Note 5)	Maximum ratio of Interference Power to Signal Power for BER < 10 ⁻⁸				
	a) With 0ft cable from DSX b) With 450ft cable from DSX		-9 -10		dB dB

- Note 1: Signal source should meet DS3 template of ANSI-T102.1993 Figure 4 and STS-1 template of ANSI-T102.1993 Figure 5. Loss characteristics of the WE728A or RG59B cable should be better than Figure C2 of ANSI-T102.1993.
- Note 2: Min spec corresponds to minimum DSX amplitude, 5.5dB of cable loss (450ft) and 6dB of flat attenuation. Error-free receiver performance is guaranteed for up to 600ft of cable from DSX cross-connect. Typical part can handle up to 900ft.
- Note 3: Min spec corresponds to amplitude of 425mVpk at DSX, 5.5dB of cable loss (450ft) and 20dB of flat attenuation. In monitor mode, interfering tone performance is not guaranteed.
- Note 4: In this mode, no noise, jitter, or interfering tone impairments should be added for guaranteed receiver performance.
- Note 5: Interfering signal is a non-synchronous sinusoidal tone of 22.368MHz for DS3 or 25.92MHz for STS-1. Data is a PRBS15 (2¹⁵-1) pattern.

78P2341JAT
E3/DS3/STS-1 LIU
with Jitter Attenuator

ELECTRICAL SPECIFICATIONS (continued)

E3 – RECEIVER (Transformer-coupled)

PARAMETER	CONDITION	MIN	TYP	MAX	UNIT
Peak Differential Input Amplitude, LINP _x and LINN _x	MON=0 (See Note 1)	120		1200	mVpk
	MON=1 (See Note 2)	25		100	mVpk
Flat-loss Tolerance	MON=0. All valid cable lengths.	0		6	dB
Receive Clock Jitter	With 100Hz-800kHz filter:				
	a) Normal receive mode b) Remote loopback mode			0.1 0.06	UIpp UIpp
Interfering Tone Tolerance (see Note 3)	Maximum ratio of Interference Power to Signal Power for BER < 10 ⁻⁸				
	a) With 0ft cable b) With 900ft cable			-9 -10	dB dB

Note 1: Min spec corresponds to signal amplitude of 950mVpk at source, 12dB of cable loss (1100ft) and 6dB of flat attenuation. Error-free receiver performance is guaranteed for all cable less than 1100ft. Typical part can handle up to 1350ft.

Note 2: Min spec corresponds to signal amplitude of 1000mVpk at source, 12dB of cable loss (1100ft) and 20dB of flat attenuation. In monitor mode, interfering tone performance is not guaranteed.

Note 3: Interfering signal is a non-synchronous E3 signal of the specified power level below the desired E3 signal. Both data and interfering signals are PRBS23 (2²³-1) pattern.

78P2341JAT

E3/DS3/STS-1 LIU

with Jitter Attenuator

ELECTRICAL SPECIFICATIONS (continued)

RECEIVER JITTER TOLERANCE

The 78P2341JAT receive jitter tolerance exceeds all specifications as shown on the graph below.

PARAMETER	CONDITION	MIN	NOM	MAX	UNIT
Receiver High Frequency Jitter Tolerance	> 60 kHz	0.75			UIpp

Jitter Tolerance: 78P234x vs. Standards

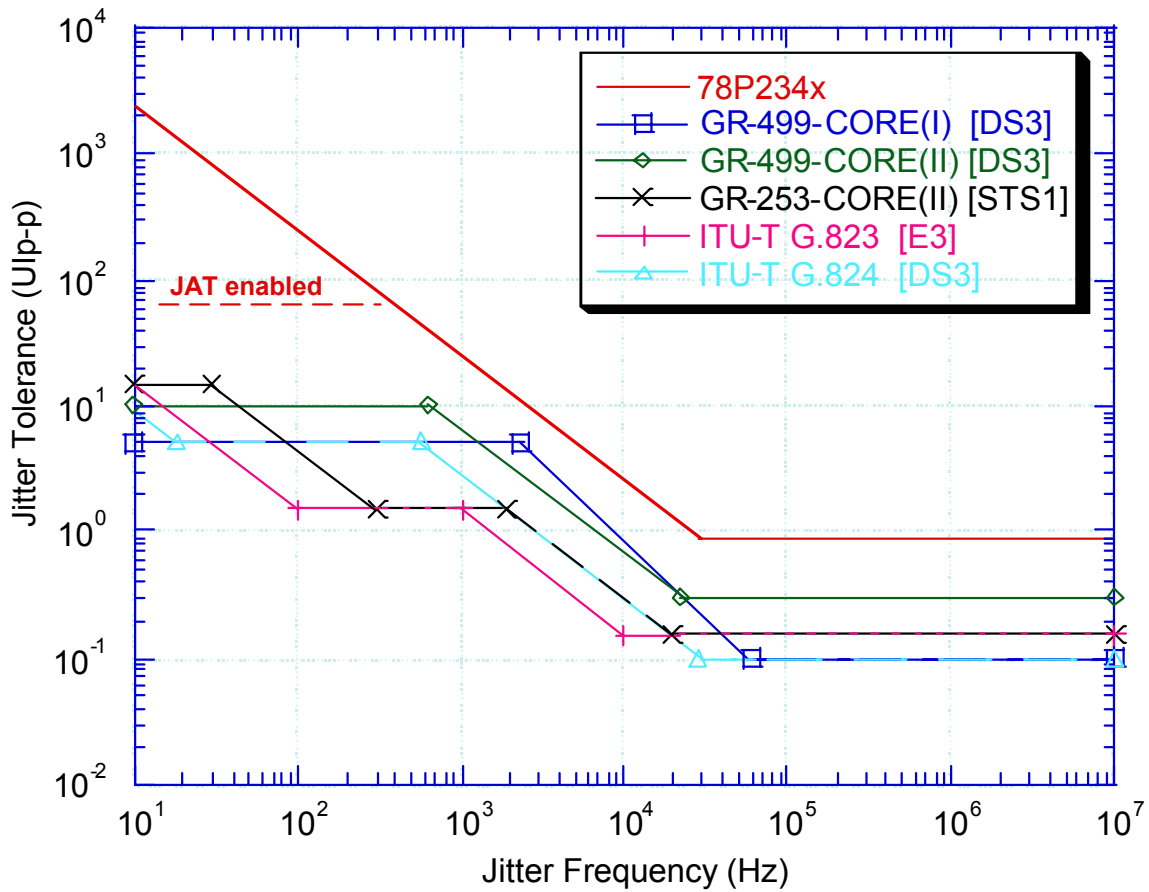

78P2341JAT E3/DS3/STS-1 LIU with Jitter Attenuator

ELECTRICAL SPECIFICATIONS (continued)

RECEIVER JITTER TRANSFER FUNCTION

The receiver clock recovery loop characteristics are such that the receiver has the following transfer function. When the Jitter Attenuator (JAT) is enabled in the receive or transmit path, the receiver or transmitter will exhibit a jitter transfer as shown in the graph and table below. Jitter Attenuator operation is guaranteed through digital scan testing. The actual jitter transfer is guaranteed by logic design and is not tested during production testing.

PARAMETER	CONDITION	MIN	NOM	MAX	UNIT
Receiver Jitter transfer function	Below Fc			0.1	dB
Receiver Jitter Bandwidth, Fc	At -3dB point JABW= 0, E3 mode (default) JABW= 1, E3 mode			13 188	Hz
	JABW= 0, DS3 mode (default) JABW= 1, DS3 mode			17 245	
	JABW= 0, STS1 mode JABW= 1, STS1 mode (default)			20 283	
	JAEN= 0, JAT disabled			55	
Jitter transfer function roll-off	After Fc	20			dB per decade

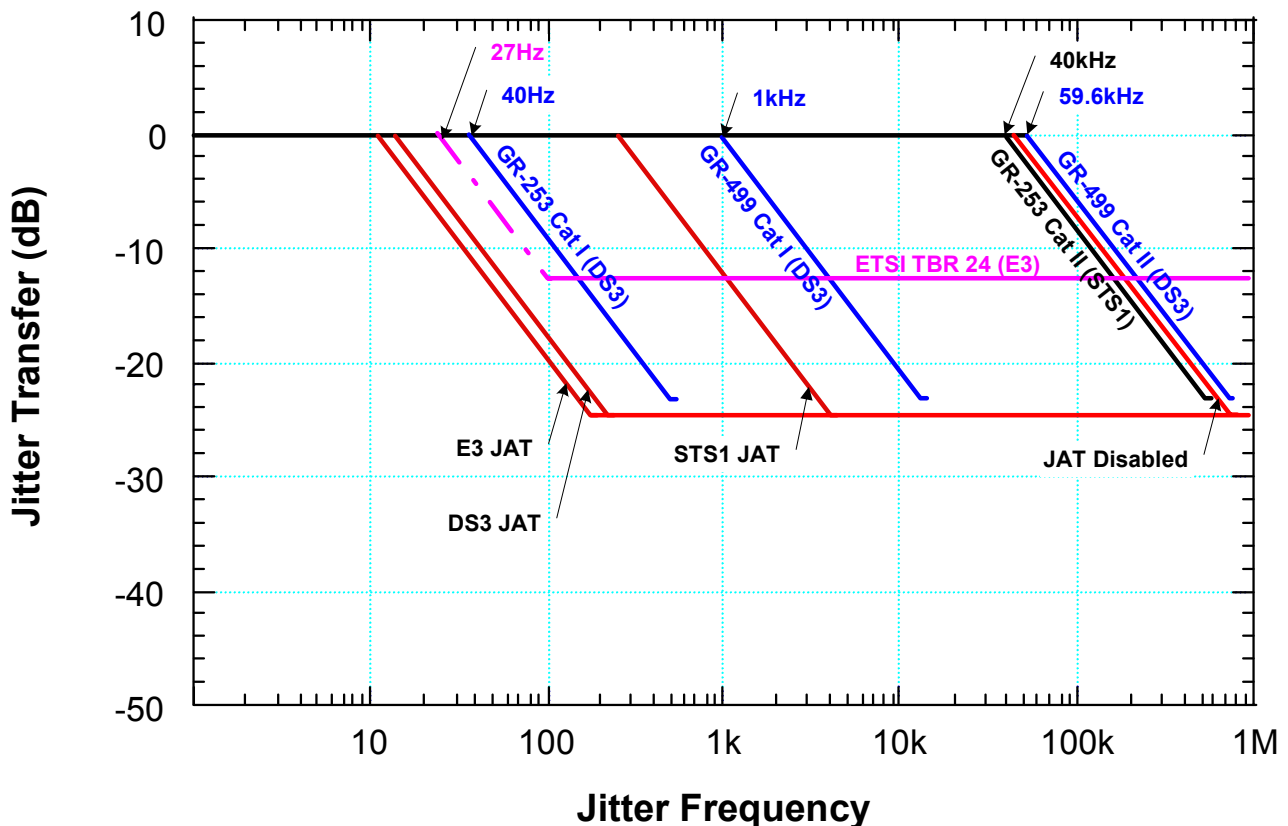

78P2341JAT

E3/DS3/STS-1 LIU

with Jitter Attenuator

APPLICATION INFORMATION

EXTERNAL COMPONENTS:

COMPONENT	PIN(S)	VALUE	UNITS	TOLERANCE
Receiver Termination Resistor	LINP LINN	75	Ω	1%
Transmitter Termination Resistor	LOUTP LOUTN	402	Ω	1%

TRANSFORMER SPECIFICATIONS:

COMPONENT	VALUE	UNITS	TOLERANCE
Turns Ratio for the Receiver		1:1	
Turns Ratio for the Transmitter (center-tapped)		1:2CT	

Suggested Manufacturer: Pulse, TDK, Halo

SCHEMATICS

For the latest typical application schematics, please check TDK Semiconductor's website or contact your local sales representative for the latest application note(s) and/or demo board manuals.

78P2341JAT
E3/DS3/STS-1 LIU
with Jitter Attenuator

PACKAGE INFORMATION

MECHANICAL SPECIFICATIONS

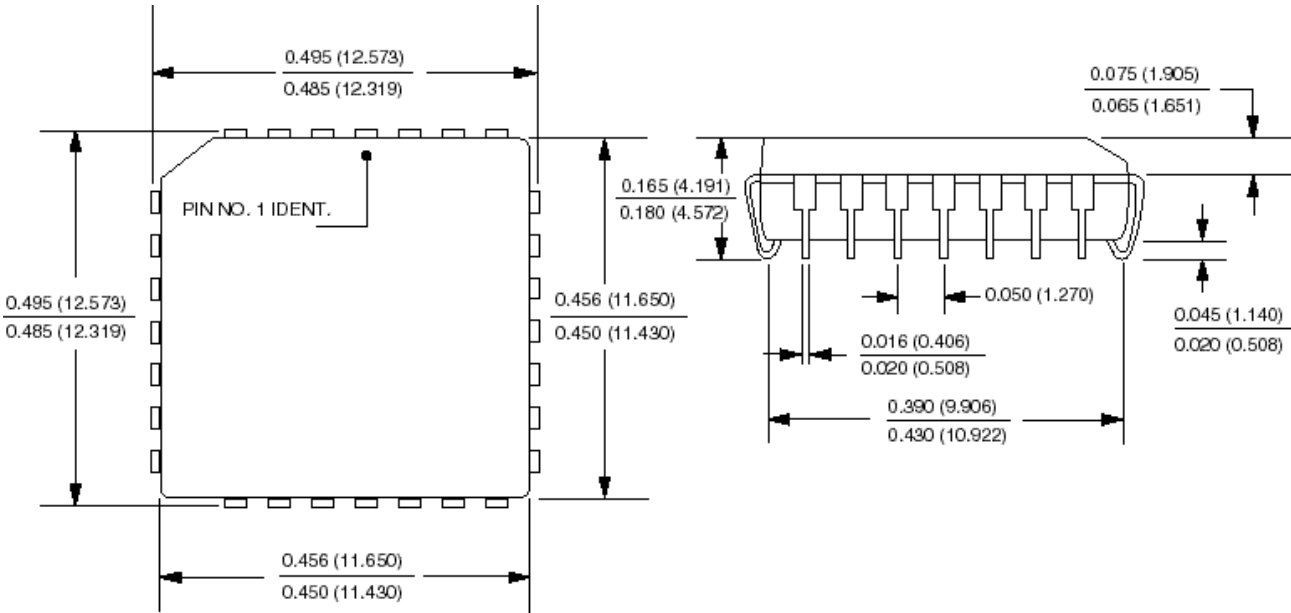

28-pin PLCC
Mechanical Specification

78P2341JAT

E3/DS3/STS-1 LIU

with Jitter Attenuator

PACKAGE INFORMATION

MECHANICAL SPECIFICATIONS

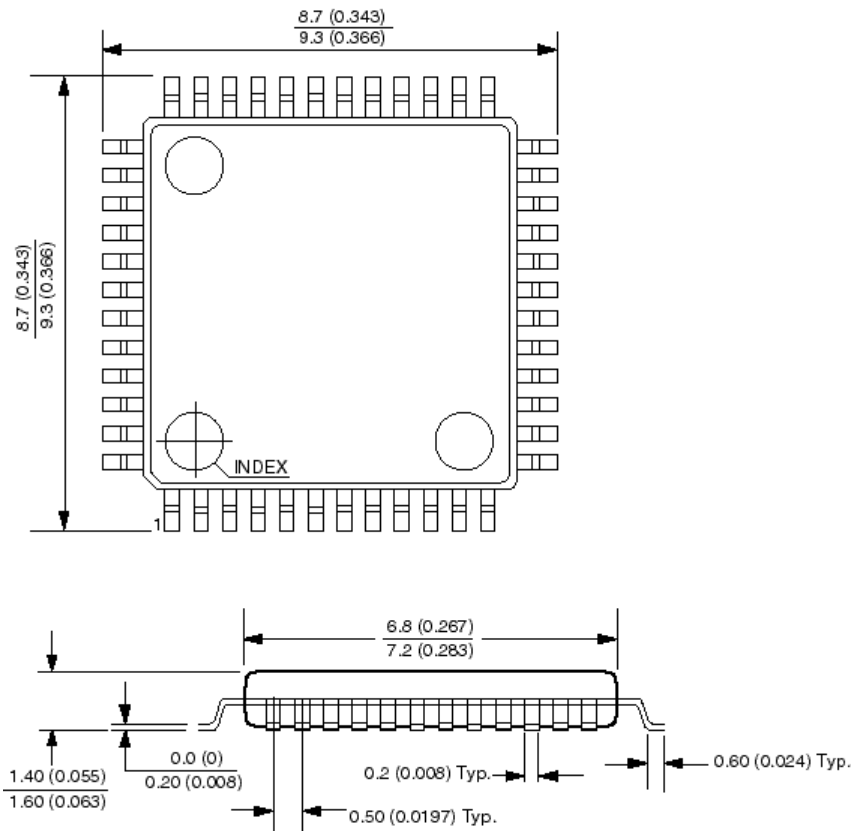

48-pin TQFP (JEDEC LQFP)
Mechanical Specification

78P2341JAT
E3/DS3/STS-1 LIU
with Jitter Attenuator

PACKAGE INFORMATION

PIN-OUT

(Top View)

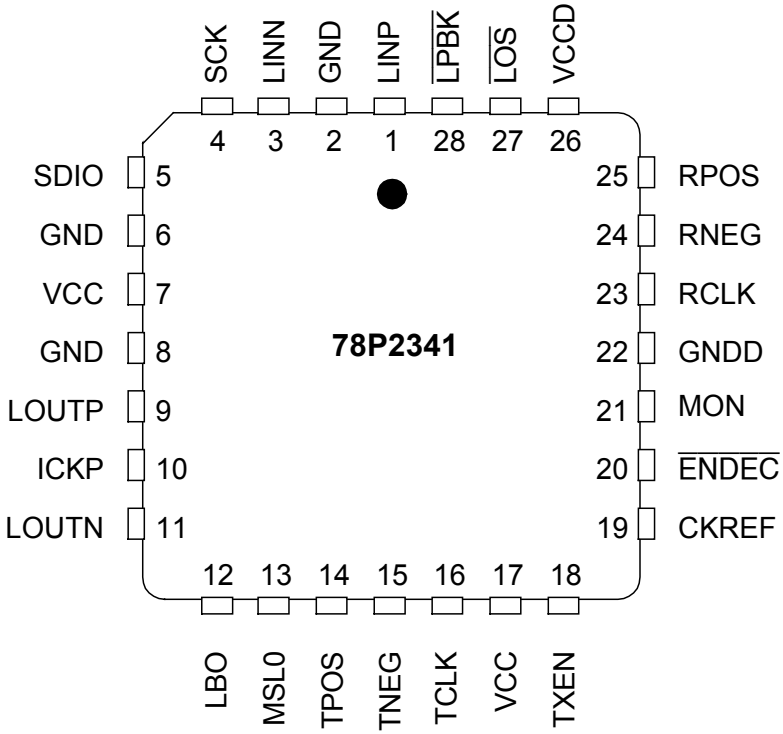

28-pin PLCC

78P2341JAT E3/DS3/STS-1 LIU with Jitter Attenuator

PACKAGE INFORMATION

PIN-OUT

(Top View)

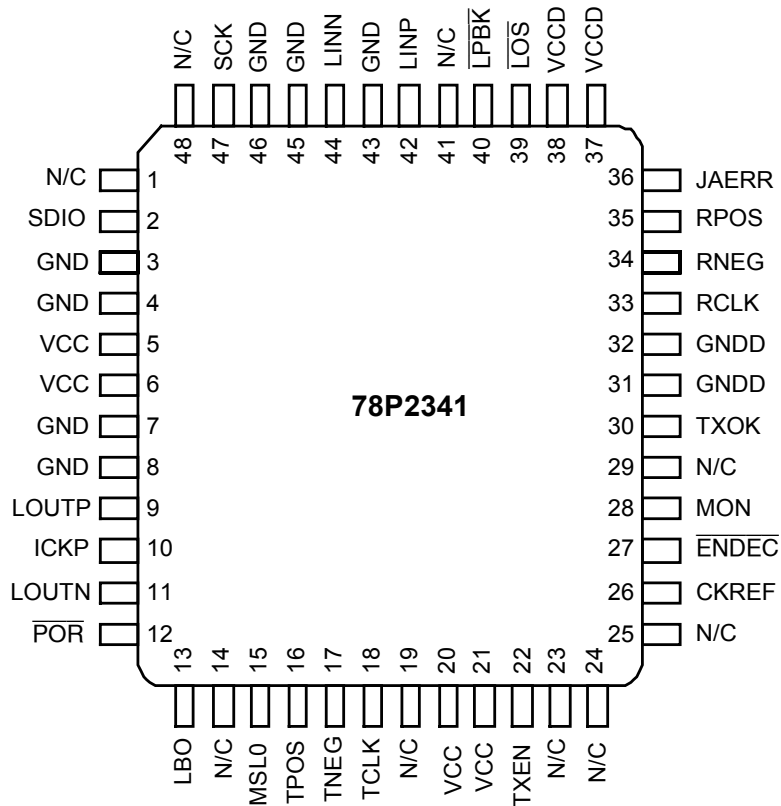

ORDERING INFORMATION

PART DESCRIPTION	ORDER NUMBER	PACKAGE MARK
48-pin JEDEC LQFP	78P2341JAT-IGT	78P2341J-IGT
28-pin PLCC	78P2341JAT-IH	78P2341J-IH
Tape & Reel option	<i>append 'R'</i>	n/a
Lead-free option	<i>append 'IF'</i>	<i>append 'IF'</i>

78P2341JAT E3/DS3/STS-1 LIU with Jitter Attenuator

REVISION HISTORY

Revision Date:	Revision Description:
June 24, 2002	<ul style="list-style-type: none">▪ Changes to 48-TQFP pinout (pins 14, 19, 23)▪ Additions to CKREF pin description▪ Corrected LPBK pin description and Intrinsic Transmit Jitter spec.▪ Marketing number change
August 06, 2003	<p>Changed to Preliminary Status</p> <ul style="list-style-type: none">▪ Updated Receive Jitter Tolerance and Jitter Transfer graphs▪ Removed SGHI bit definition▪ Updated Internal Power on Reset description▪ Updated timing diagrams & e-spec table values▪ Changed recommended Rx / Tx termination resistor values to 75 / 402 ohm respectively

Preliminary Data Sheet: This Preliminary Data Sheet describes a product not completely released to production. The specifications are based on preliminary evaluations and may not be accurate. Samples of the described product are available and limited quantities can be purchased. TDK Semiconductor Corporation should be consulted for the most current up-to-date information about the product.

If and when manufactured and sold, this product is sold subject to the terms and conditions of sale supplied at the time of order acknowledgment, including those pertaining to warranty, patent infringement and limitation of liability. TDK Semiconductor Corporation (TSC) reserves the right to make changes in specifications at any time without notice. Accordingly, the reader is cautioned to verify that a data sheet is current before placing orders. TSC assumes no liability for applications assistance.

TDK Semiconductor Corp., 6440 Oak Canyon Rd., Irvine, CA 92618
TEL (714) 508-8800, FAX (714) 508-8877, <http://www.tdksemiconductor.com>