



# NATIONAL HYBRID INC.

2200 SMITHTOWN AVE., RONKONKOMA N.Y., 11779  
VOICE 631-981-2400 FAX 631-981-2445

## NHi-15901/15LV901 Bus + Mil-Std-1553 +5v/+3.3v Transceiver and Transformer

### Features:

- Compliant with Mil-Std-1553 and Mil-Std 1760
- NHi proprietary transceiver ASIC
- Pulse 1553 dual ratio transformer
- Short circuit tolerant
- Low dissipation power
- Superior noise filter

### Description:

The NHi-15901 “Bus +” contains the transceiver and transformer necessary to couple to the Mil-Std-1553 bus. The receiver converts the 1553 bus bi-phase data to complementary RXOUT\_H and RXOUT\_L digital outputs for use by the Manchester decoder. The transmitter outputs bi-phase Manchester to the coupling transformer when the TXIN\_H and TXIN\_L inputs are driven by complementary digital data.

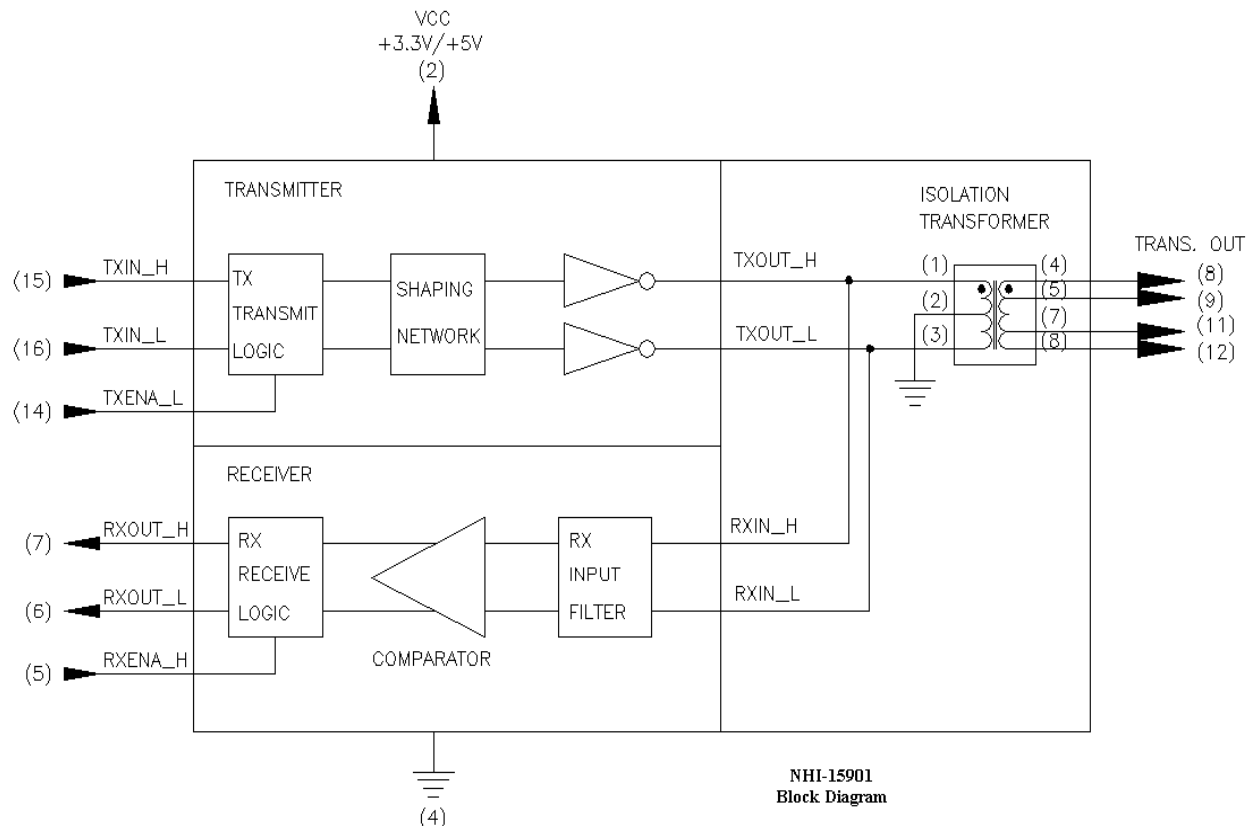

NHI-15901  
Block Diagram

# NHi-15901/15LV901      Bus +

## ABSOLUTE MAXIMUM RATINGS

Parameter	Symbol	Min.	Max.	Units
Power Supply	Vcc_+5.0	-0.3	+7.0	Vdc
Power Supply	Vcc_+3.3	-0.3	+3.9	Vdc
Receiver Differential Input Voltage	Vcc_+5.0	--	15	Vpp
Receiver Differential Input Voltage	Vcc_+3.3	--	12	Vpp
Peak Transmitter Current	Ipkmax	--	1.0	A
Solder Temperature	Tsold	--	+245	°C
Storage Temperature	Tstor	-55	+130	°C
Input Zapping	Vzap	2000	--	Vdc
Logic Input Current	Ilgc	-10	--	μA

## Transceiver Electrical Specifications

PARAMETER	CONDITION	SYMBOL	MIN	TYP	MAX	UNITS
Rise/Fall Time	Resistive Load On Xfmr	Tr/Tf	100	170	250	ns
Dynamic Offset	Measured On Stub	Vdo	-250	--	+250	mVp
Output Noise	On Stub; Not Transmitting	Vno	--	--	10	mVrms
Output Impedance	On Stub; Not Transmitting	Zo	3k	--	--	Ω
Input Level	On Stub	Vin	--	--	15	Vpp
Receiver Threshold	Referred To Stub	Vthr	400	600	860	mVpp
Common Mode Rejection with Transformer	DC to 2 MHz	Cmrr	40	--	--	dB

# NHi-15901/15LV901      Bus +

## General Electrical Specifications

PARAMETER	CONDITION	SYMBOL	MIN	TYP	MAX	UNITS
Power Supply	75Ω Load On Stub	Vcc_+5.0	4.75	5.00	5.25	Vdc
		Vcc_+3.3	3.15	3.30	3.45	
Output Voltage	75Ω Load On Stub	Vout	20	22	24	Vpp
Current	Standby; Not Transmitting	Istby	--	13	17	mA
Transmitter Current	100% Duty Cycle; One Channel Transmitting; 75Ω Load On Stub	Id_+5.0	--	525	550	mA
		Id_+3.3	--	730	766	
Total Power Dissipation	100% Duty Cycle; One Channel Transmitting; 75Ω Load On Stub	Pd_+5.0	--	1.07	1.2	W
		Pd_+3.3	--	0.84	0.92	
Operating Temperature	Case	Tc	-55	--	+130	°C
Thermal Impedance	Junction to Case	θjc	--	--	6	°C/W
<b><i>Logic I/O</i></b>						
Vin High		Vih	2	--	--	V
Vin Low		Vil	--	--	0.8	V
Iin High	Vih = 2.7v	Iih	20	--	50	μA
Iin Low	Vil = 0.4v	Iil	-20	--	-50	μA
Vout High	Ioh = 4ma	Voh	2.3	--	--	V
Vout Low	Iol = 4ma	Vol	--	--	0.4	V

**Transmitter Logic**

TXIN_H <sup>[1]</sup>	TXIN_L <sup>[1]</sup>	TXENA_L <sup>[1]</sup>	Bus
0	0	0	Hi_Z
1	0	0	Vpp
0	1	0	Vpp
1	1	0	Hi_Z
X	X	1	Hi_Z

Notes: [1] This input has a weak pull-up resistor to Vcc. The value is 50kΩ to 100kΩ.

**Receiver Logic**

RXENA_H	Stub/Bus	RXOUT_H	RXOUT_L
1	Vthr- <Vpp< +Vthr	0	0
1	Vthr- <Vpp>= +Vthr	1	0
1	Vthr- =>Vpp< +Vthr	0	1
0	X	0	0

**Transformer Specifications**

Device	Terminals	Ratio	RDC (Ω MAX)	Impedance (Ω MIN)
NHi-15901	(1-3):(8-12)	1CT:2.50CT	(1-3) 0.8	(8-12) 4000
	(1-3):(9-11)	1CT:1.79CT	(8-12) 3.5	
NHi-15LV901	(1-3):(8-12)	1CT:3.54CT	(1-3) 0.8	(8-12) 4000
	(1-3):(9-11)	1CT:2.50CT	(8-12) 3.5	

# NHi-15901/15LV901

# Bus +

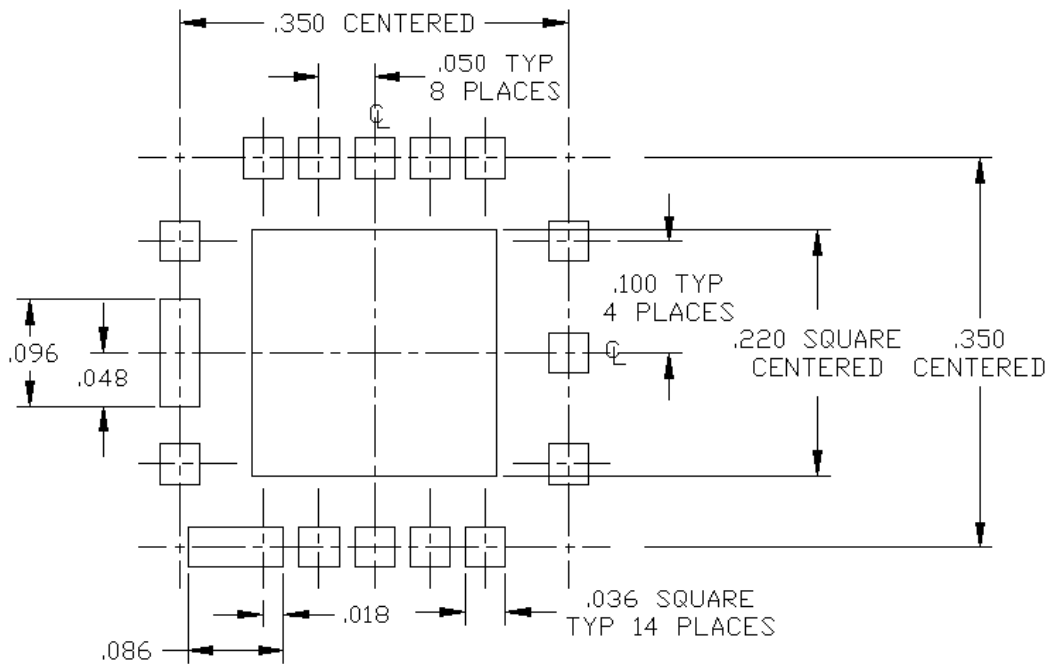
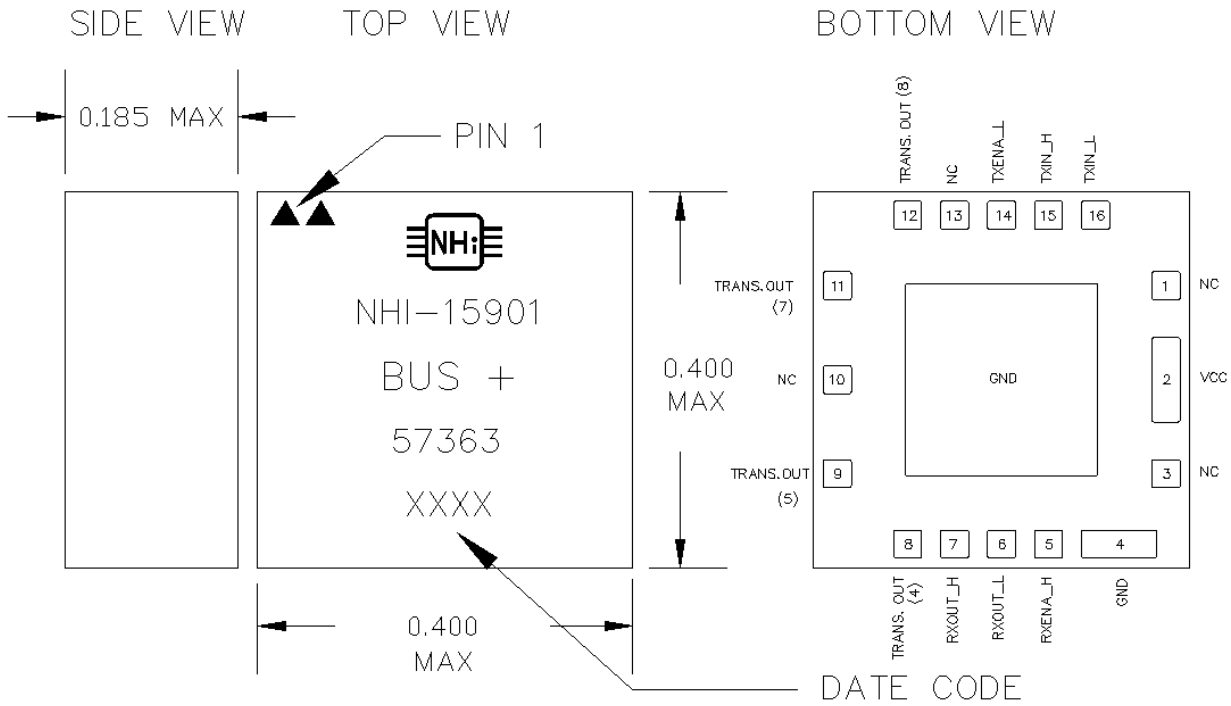

SUGGESTED PAD LAYOUT

- Notes:**
1. All dimensions are in inches.
  2. Center pad of the device must be soldered to the ground plane.

# NHi 15901/15LV901 Bus +

## Ordering Information

NHi-15LV901/T

└───┬───> Grade  
Blank  
/T

Industrial: -40 to +85°C  
Military: -55 to +125°C

└───┬───> Device  
15LV901  
15901

V<sub>cc</sub> = 3.3V  
V<sub>cc</sub> = 5.0V