

FEATURES

- 27 dB Gain
- Very Low Distortion
- Excellent Input/Output Match
- Low DC Power Consumption
- Good RF Stability with high VSWR Load Conditions
- Surface Mount Package
- Package Fully Automatic Assembly Compatible
- Low Cost
- Repeatability of Monolithic Fabrication
- Meets Cenelec Standard

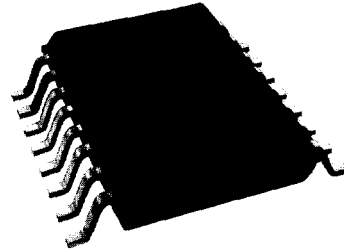

S7
16 Pin Plastic Pin Package

Description

The ACA2403 surface mount monolithic GaAs RF Linear Amplifier has been developed to replace, in new designs, the standard CATV Hybrid amplifiers currently in use. The MMIC consists of two pair of parallel amplifiers. The Amplifiers are optimized for exceptionally low distortion and noise figure while providing flat gain and excellent input and output return loss. A Hybrid equivalent is formed when one ACA2403 is cascaded between two transmission line baluns.

Absolute Maximum Ratings

PARAMETER	MIN	MAX	UNITS
V_{DD}/V_{RFOUT}	0	28	VDC
RF_N	-	+70	dBmV
Storage Temperature	-65	+150	°C
Soldering Temperature	-	+260	°C
Soldering Time	-	5.0	Sec
Thermal Resistance	-	3.8	°C/W
Operating Temperature	-40	110	°C

The ACA2403 is designed as a high gain input stage and is specified at +44 dBmV flat output.

Electrical Specifications (TA=+25°C, VDD=24V, test circuit shown in fig.1)

PARAMETER	ACA2403		
	MIN	TYP	MAX
Bandwidth	40	-	870
Gain @870 MHz ¹	-	27	-
Cable Equivalent Slope ¹	-	0.5	-
Gain Flatness @ 870 MHz ¹	-	± 0.2	-
Noise Figure ¹	-	3.0	-
CTB ^{1,2} 77 Channels 110 Channels 128 Channels	- - -	- 63 -	- - -
CSO ^{1,2} 77 Channels 110 Channels 128 Channels	- - -	- -68 -	- - -
XMOD ^{1,2} 77 Channels 110 Channels 128 Channels	- - -	- -60 -	- - -
Supply Current	-	290	-
Return Loss (Input/Output) ¹	18	22	-

Notes:

1. Measured with a balun on input and output of the device. See Figure 1 for test setup.
2. Parts measured with 110 channel flat output @ +44 dBmV/channel.

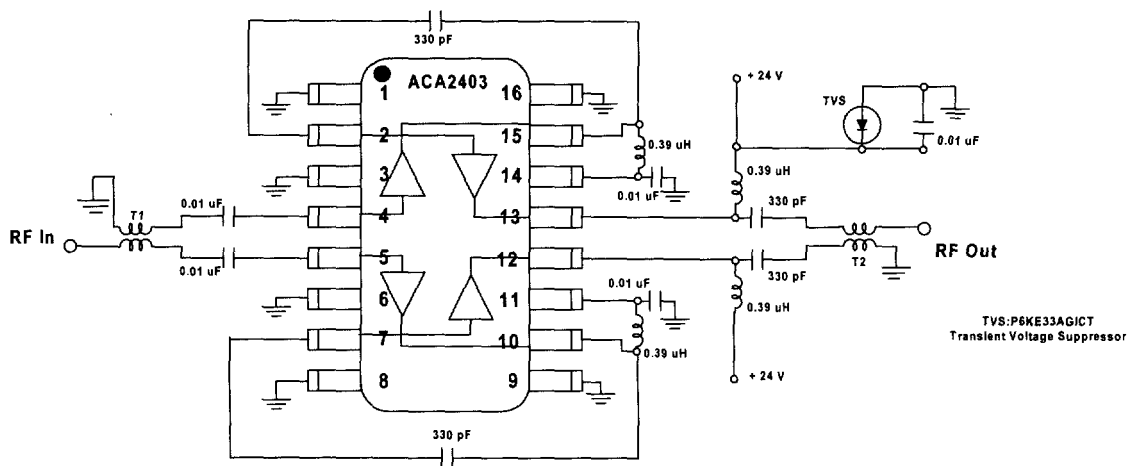

Figure 1: Test Circuit for ACA2403

Package Outline

1
Cable & Broadcast
Products

