

MAP Erbium-Doped Fiber Amplifier

EDFA Series



For stand-alone applications, the MAP EDFA may be used as a benchtop

Key Features

- High output power and gain
- Low noise figure
- Monitoring and alarms

Applications

- In-line, pre-amp and booster amplifier emulation
- Dense wavelength division multiplexing (DWDM) transmission for multi-channel applications
- SONET/SDH systems for single channel applications
- Optical signal to noise ratio (OSNR) experiments

The Multiple Application Platform (MAP) Erbium-Doped Fiber Amplifier (EDFA) Cassette combines the optical performance of the traditional JDSU EDFA benchtop models, with the flexibility and modularity of the MAP. Nine standard configurations are available to meet your needs. The MAP EDFA has a saturated output power ranging from 14 dBm to 21 dBm, features noise figures as low as 3.3 dB and has gain flatness better than 1.4 dB. The MAP EDFA's are available for operation in the C- or L-band.

The MAP EDFA models provide specialized variants and optical performance not available in the Benchtop EDFA line. Additional EDFA models are available in the Benchtop EDFA product line for applications requiring higher saturated power or operation in the C+L-band.

Safety Information

- This optical source cassette, when installed in the MAP chassis, complies to CE requirements plus UL3101-1 and CAN/CSA-C22.2 No.1010.1, meets the requirements of Class 3B in standard IEC 60825-1 (2002), and complies with 21 CFR 1040.1 except deviations per Laser Notice No.50, July 2001.

INVISIBLE LASER RADIATION
AVOID EXPOSURE TO BEAM
CLASS 3B LASER PRODUCT
(IEC 60825-1, 2002)
MAX. 500 mw, 700-1680 nm

2

Specifications

Parameter	1546	1550	1552	1552	1554	1558	1590	1592	1594
Amplifier type	Mid-span access booster DWDM	Pre-amp	Booster	Booster high power	In-line	Booster DWDM	Pre-amp	Booster	In-line
Operating wavelength range	1540 to 1560 nm	1528 to 1565 nm	1528 to 1565 nm	1528 to 1565 nm	1528 to 1565 nm	1528 to 1563 nm	1565 to 1610 nm	1565 to 1610 nm	1565 to 1610 nm
Input signal	Multichannel (DWDM)	Single channel	Single channel	Single channel	Single channel	Multichannel (DWDM)	Single Channel	Single Channel	Single Channel
Saturated output power (minimum) ¹	≥ 17 dBm	≥14 dBm	≥17 dBm	≥ 20 dBm	≥ 17 dBm	≥ 21 dBm	≥ 15 dBm	≥ 15 dBm	≥ 20 dBm
Noise figure (maximum) ²	≤ 5.5 dB	≤ 3.3 dB	≤ 4.5 dB	≤ 5.0 dB	≤ 3.8 dB	≤ 5.5 dB	≤ 5.0 dB	≤ 5.5 dB	≤ 5.5 dB
Small signal gain (minimum) ³	≥ 23 dB (MS loss ≤ 10 dB)	≥ 37 dB	≥ 30 dB	≥ 32 dB	≥ 35 dB	≥ 25 dB	≥ 24 dB	≥ 22 dB	≥ 28 dB
Input/output monitors	Yes	No	Yes	Yes	No	Yes	No	Yes	Yes
Polarization dependent loss (PDL) (maximum)	≤ 0.3 dB	≤ 0.2 dB	≤ 0.2 dB	≤ 0.2 dB	≤ 0.2 dB	≤ 0.25 dB	≤ 0.3 dB	≤ 0.3 dB	≤ 0.3 dB
Polarization mode dispersion (PMD) (maximum)	≤ 0.6 ps	≤ 0.5 ps	≤ 0.4 ps	≤ 0.4 ps	≤ 0.5 ps	≤ 0.65 ps	≤ 0.6 ps	≤ 0.6 ps	≤ 0.6 ps
Input/output isolation (typical)	32/32 dB	N/A/32 dB	45/32 dB	45/32 dB	32/32 dB	32/32 dB	N/A/40 dB	40/40 dB	40/40 dB
Spectral gain flatness (maximum) (p-p) ⁴	≤ 1.6 dB	N/A	N/A	N/A	N/A	≤ 1.4 dB	N/A	N/A	N/A
Operating temperature	0 to 40 °C								
Storage temperature	-30 to 60 °C								
Humidity	Maximum 95% RH non-condensing from 0 to 45 °C								
Dimensions (W x H x D)	4.06 x 13.24 x 39.5 cm								
Weight	2.3 kg								

Note: All specifications guaranteed at 1550 nm and at 23 °C.

1. Saturated Output Power measured:

- at 1550 nm at $P_{in} = -4$ dBm
- at 1550 nm at $P_{in} = -6$ dBm for model 1546
- at 1550 nm at $P_{in} = -4$ dBm (mid-span) for models 1550, 1552, 1554, 1558
- at 1590 nm at $P_{in} = -4$ dBm (mid-span) for models 1590, 1592, 1594

2. Noise figure measured:

- at $P_{in} = -6$ dBm (pre-amp) for model 1546
- at $P_{in} = -30$ dBm for model 1550
- at $P_{in} = -4$ dBm for models 1552, 1558, 1592
- at $P_{in} = -20$ dBm for models 1554, 1590, 1594

3. Small signal gain measured:

- at $P_{in} = -6$ dBm for model 1546
- at $P_{in} = -30$ dBm for model 1550
- at $P_{in} = -20$ dBm for model 1552, 1554, 1590, 1592, 1594
- at $P_{in} = -4$ dBm for model 1558

4. Flatness optimized:

- for $P_{in} = -4$ dBm for model 1558
- for $P_{in} = -6$ dBm for model 1546

Ordering Information

For more information on this or other products and their availability, please contact your local JDSU account manager or JDSU directly at 1-800-498-JDSU (5378) in North America and +800-5378-JDSU worldwide or via e-mail at customer.service@jdsu.com.

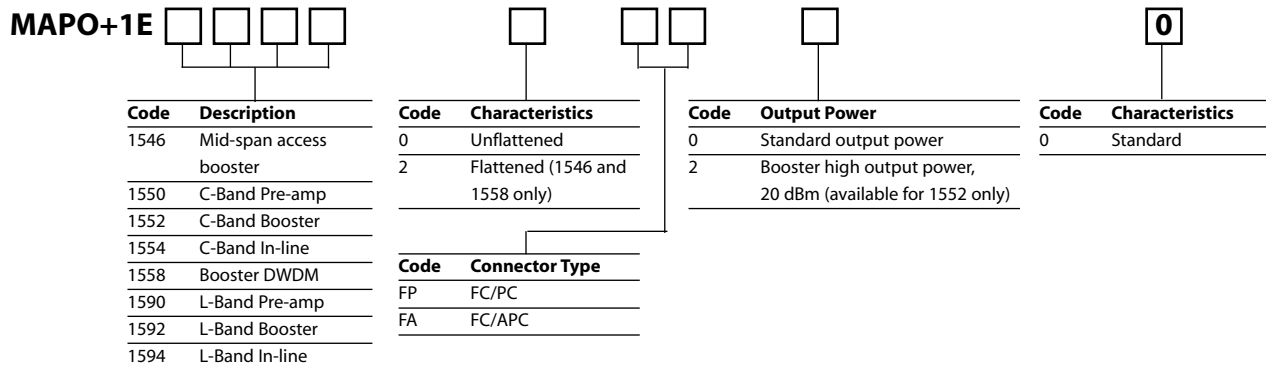
Sample: MAPO+1E15520FP20

UL is a registered trademark of Underwriters Laboratories Inc.

All statements, technical information and recommendations related to the products herein are based upon information believed to be reliable or accurate. However, the accuracy or completeness thereof is not guaranteed, and no responsibility is assumed for any inaccuracies. The user assumes all risks and liability whatsoever in connection with the use of a product or its application. JDSU reserves the right to change at any time without notice the design, specifications, function, fit or form of its products described herein, including withdrawal at any time of a product offered for sale herein. JDSU makes no representations that the products herein are free from any intellectual property claims of others. Please contact JDSU for more information. JDSU and the JDSU logo are trademarks of JDS Uniphase Corporation. Other trademarks are the property of their respective holders. ©2006 JDS Uniphase Corporation. All rights reserved. 21031269 Rev.006 03/06 MAPEDFA.DS.TM.AE

Test & Measurement Regional Sales

NORTH AMERICA TEL: 1 866 228 3762 FAX: +1 301 353 9216	LATIN AMERICA TEL: +55 11 5503 3800 FAX: +55 11 5505 1598	ASIA PACIFIC TEL: +852 2892 0990 FAX: +852 2892 0770	EMEA TEL: +49 7121 86 2222 FAX: +49 7121 86 1222	WEBSITE: www.jdsu.com
---	--	---	---	--