

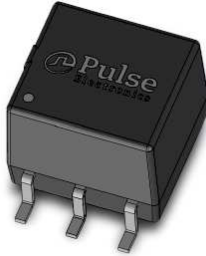





COPPERHEAD HIGH SPEED SINGLE TRANSFORMER

Military/Aerospace Grade



-  Compliant with ANSI X3T111, Fiber Channel, FC-PH-3 for quarter/full speed applications, SMPTE, IEEE1394 Firewire
-  Moisture sensitivity Level 3
-  Pick and place compatible
-  IC grade package withstands 225°C peak Temperature profile
-  Operating Temperature -55°C to +125 °C

Electrical Specifications @ 25°C - Operating Temperature -55°C to +125°C

Part Number*	Turns Ratio (±5%)	Primary Inductance (μH MIN)	Rise Time @20 & 80% (pS MAX)	DCR (Ω MAX)	Hi-Pot (Vrms MIN)	Insertion Loss (dB MAX)	Application Nominal Bit Rate (Mbaud)
T-330ACT	1CT:1CT	26	350.000	0.2	1500	-1.50	265.6(fullspeed)
T-531ACT	1CT:1CT	7.5	325.000	0.2	1500	-2.00	531 (full speed)
T-1062ACT	1CT:1CT	3.75	280.000	0.2	1500	-2.00	1,062.5(fullspeed)
T-1250ACT	1CT:1CT	3.75	280.000	0.2	1500	-2.00	1,250(fullspeed)
T-1485ACT	1CT:1CT	3.75	280.000	0.2	1500	-2.00	1,485(fullspeed)

* Adding suffix "NL" to the part number (i.e. T-1485ACTNL) indicates a RoHS-compliant part number.

Mechanical

Schematic

T-330ACT, T-531ACT, T-1062ACT, T-1250ACT, T-1485ACT

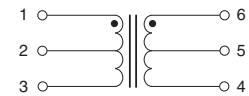
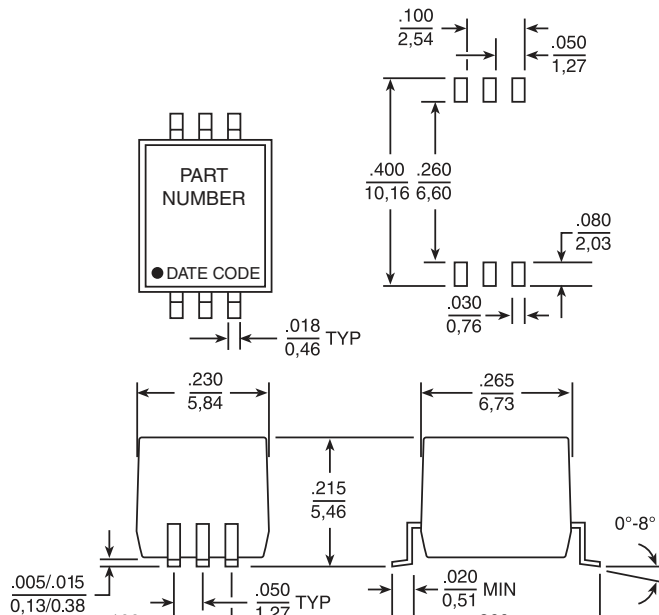

NOTE COPLANARITY 0.004" (0.102MM) MAXIMUM
 Weight 0.5 grams
 Tube 80/tube
 Tape & Reel 750/reel
 Dimensions: Inches
 mm
 Unless otherwise specified, all tolerances are ±.005
 0.13

Application Notes

Pulse Specialty Components has designed Fibre Channel dual transformers specifically for point to point coupling to 150Ω twinax cable. The isolation transformers protect the station from static charges that may develop on the cable, and prevents ground loop currents from being transferred between stations. The devices have

also been designed to provide common mode rejection within the transmission band and thus reduce EMI. The wide bandwidth of these devices minimizes data dependent jitter by providing fast signal rise times. Low-end bandwidth also minimizes base-line wander, another contributor to jitter. The dual package allows connection

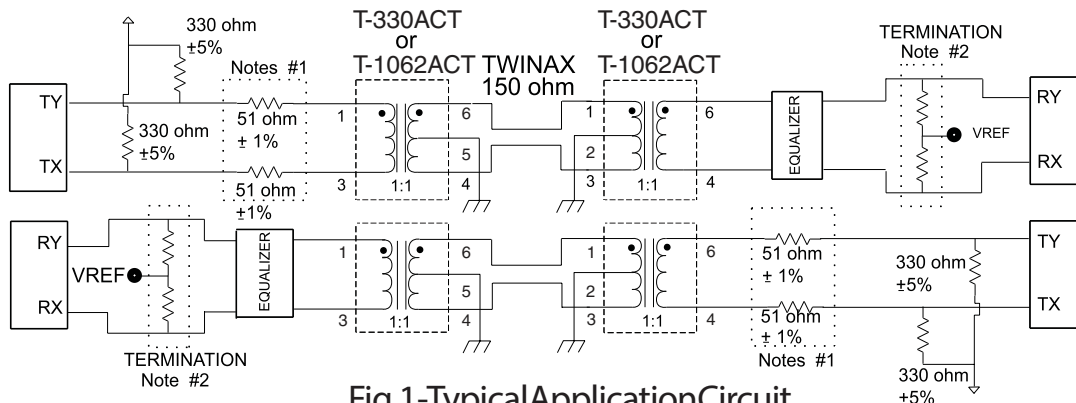

Fig. 1 - Typical Application Circuit

1. The transformer, 51Ω resistors, and the impedance of the driver are matched to achieve the best return loss (S11) for the transmitter of the 150Ω system.
2. The total impedance of termination resistor network is 150Ω.
3. When laying out PCB, transmission line methods must be utilized to maintain return loss and signal integrity. Transformer must be located within .50" of the

- DB9 connector.
4. It is recommended that the center tap (CT) of transformer(s), cable side, be connected to earth/chassis (cable shield) ground either directly or via a transient voltage suppressor (TVS) type component and earth/chassis ground should be "AC-coupled" to signal (digital) ground through a .027μF, 500V capacitor.

For More Information

Pulse North America Headquarters
Two Pearl Buck Court
Bristol, PA 19007
U.S.A.

Pulse Europe
Zeppelinstrasse 15
71083 Herrenberg
Germany

Pulse China Headquarters
B402, Shenzhen 10th
Kejinan Road
High-Tech Zone
Nanshan District
Shenzhen, PR China
518057
Tel: 86 755 33966678
Fax: 86 755 33966700

Pulse North China
Room 2704/2705
Super Ocean Finance Ctr.
2067 Yan An Road West
Shanghai 200336
China

Pulse South Asia
135 Joo Seng Road
#03-02
PM Industrial Bldg.
Singapore 368363

Pulse North Asia
3F No. 198, Zhongyuan
Road
Zhongli City
Taoyuan County (32068)
Taiwan

Tel: 215 781 6400
Fax: 215 781 6403

Tel: 49 7032 7806 0
Fax: 49 7032 7806 12

Tel: 86 21 62787060
Fax: 86 2162786973

Tel: 65 6287 8998
Fax: 65 6287 8998

Tel: 886 3 4356768
Fax: 886 3 4356823

Performance warranty of products offered on this data sheet is limited to the parameters specified. Data is subject to change without notice. Other brand and product names mentioned herein may be trademarks or registered trademarks of their respective owners. © Copyright, 2013. Pulse Electronics, Inc. All rights reserved.