

CX42053

700 – 1000 MHz High Dynamic Range, Diversity Receiver Front End

Conexant's CX42053 is an integrated, high-dynamic range, low-noise receiver down converter for two-channel diversity systems. It includes a Low Noise Amplifier (LNA) followed by a double-balanced active mixer. The CX42053 has dual Local Oscillator (LO) inputs, selected using an external switch interface. The internal attenuator is integrated with the LNA. The attenuator function is also controlled using an externally controlled CMOS-compatible interface.

Figure 1 shows a functional block diagram for the CX42053. The 24-pin Plastic Quad Flat Pack (PQFP) device package and pinout are shown in Figure 2.

Distinguishing Features

- High 3rd Order Input Intercept Point (IIP3) mixer and LNA
- Wideband RF input frequency range (700 to 1000 MHz)
- Single or two-channel applications
- Use with LNA-mixer cascaded or mixer-only
- Bias-selectable LNA/mixer functions
- Integrated solid state attenuator
- CMOS-compatible control interfaces
- ± 5 V supply operation
- -20 °C to $+85$ °C operating range
- Supports frequency hopping applications

Applications

- Cellular and GSM communications
- Mobile radio systems
- Paging
- Industrial, Scientific, Medical (ISM) band Applications

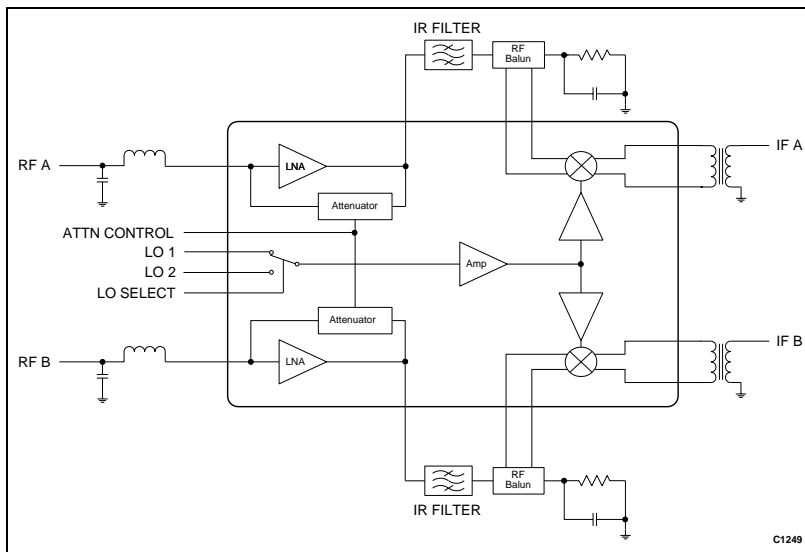

Figure 1. CX42053 Functional Block Diagram

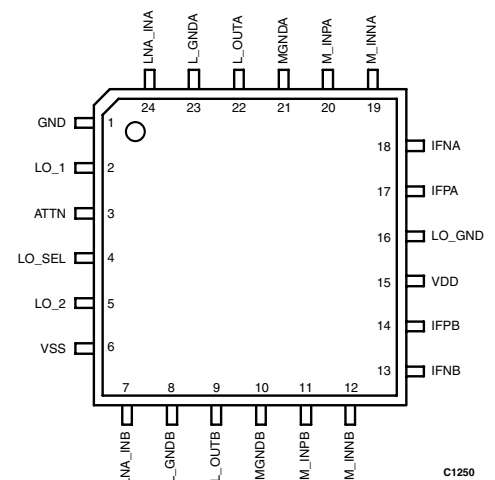

Figure 2. CX42053 Pinout – 24-Pin PQFP Package

Technical Description

The CX42053 consists of two identical channels, A and B, that were specifically designed for the purpose of diversity in base station applications.

Each channel consists of a single-ended LNA and a double-balanced differential mixer. The LNAs share a common CMOS-compatible attenuator control switch, which bypasses the LNA, providing 20 dB of attenuation.

Each channel shares two independent LO signals, LO1 and LO2, that are selected using a common CMOS-compatible control signal. With this ability, the device can be used in applications where frequency hopping is required.

The LNAs and mixers are independently biased. This allows design flexibility with power management functions in base station receivers.

Electrical and Mechanical Specifications

The signal pin assignments and functions are described in Table 1. The absolute maximum ratings of the CX42053 are provided in Table 2. The recommended operating conditions are specified in Table 3 and electrical specifications are provided in Table 4. Table 5 provides additional electrical specifications for full channel performance.

Typical performance characteristics of the CX42053 are illustrated in Figures 3 through 9.

Table 1. CX42053 Signal Descriptions

Pin #	Name	Description	Pin #	Name	Description
1	GND	Ground	13	IFNB	Channel B negative differential mixer IF output
2	LO_1	Local oscillator 1 input for channels A and B	14	IFPB	Channel B positive differential mixer IF output
3	ATTN	Channels A and B attenuator control	15	VDD	Positive supply voltage
4	LO_SEL	LO_1/LO_2 select control	16	LO_GND	Local oscillator ground
5	LO_2	Local oscillator 2 input for channels A and B	17	IFPA	Channel A positive differential mixer IF output
6	VSS	Negative supply voltage	18	IFNA	Channel A negative differential mixer IF output
7	LNA_INB	Channel B LNA input	19	M_INNA	Channel A negative differential mixer input
8	L_GNDB	Channel B LNA ground	20	M_INPA	Channel A positive differential mixer input
9	L_OUTB	Channel B LNA output	21	MGNDA	Channel A mixer ground
10	MGNDB	Channel B mixer ground	22	L_OUTA	Channel A LNA output
11	M_INPB	Channel B positive differential mixer input	23	L_GNDA	Channel A LNA ground
12	M_INNB	Channel B negative differential mixer input	24	LNA_INA	Channel A LNA input

Table 2. CX42053 Absolute Maximum Ratings

Parameter	Symbol	Min	Typical	Max	Units
Positive DC power supply	VDD			+5.5	V
Negative DC power supply	VSS			-6.0	V
Power dissipation	PD			2.25	W
Input power	PIN			+15	dBm
Thermal resistance	R _{TH}		+25		°C/W
Operating temperature	T _{OPR}	-20		+85	°C
Storage temperature	T _{STG}	-40		+125	°C

Note: No damage to device if only one parameter is applied at a time with other parameters at nominal conditions.

Table 3. CX42053 Recommended Operating Conditions

Parameter	Symbol	Min	Typical	Max	Units
Positive DC supply voltage	VDD	+4.75	+5.0	+5.25	V
Negative DC supply voltage	VSS	-4.75	-5.0	-5.25	V
Operating temperature	T _{OPR}	0		+50	°C

Table 4. CX42053 Electrical Characteristics
 (+25° C, Voltage Supply = ±5 V, LO = 0 dBm, RF Frequency = 900 MHz, IF Frequency = 110 MHz, Mixer Bias = 55 mA)

Parameter	Test Condition	Min	Typical	Max	Units
Low Noise Amplifier					
Gain		12	14		dB
Noise Figure (NF)			1.8	3.0	dB
Input IP3		16	18		dBm
-1 dB compression point		3	5		dBm
RF					
RF input frequency		700		1000	MHz
RF input (Note 1)	RF = 700 MHz to 1000 MHz		1.5:1	2.0:1	VSWR
	RF = 900 MHz, 50 Ω		1.5:1	2.0:1	VSWR
RF output (Note 1)	RF = 700 MHz to 1000 MHz		1.5:1	2.0:1	VSWR
Mixer (Note 2)					
Conversion gain	RF = 800 to 900 MHz, LO = 750 MHz	-0.5	+1.0		dB
	RF = 800 to 900 MHz, LO = 950 MHz	-0.5	+1.0		dB
	RF = 900 MHz, LO = 790 MHz	0	+2.0		dB
	RF = 900 MHz, LO = 1010 MHz	0	+1.5		dB
SSB NF	RF = 800 MHz to 1000 MHz, LO = 690 MHz		10	13	dB
	RF = 700 MHz to 1000 MHz, LO = 1010 MHz		10	13	dB
Input IP3	RF = 900 MHz, LO = 790 MHz (mixer bias = 80 mA)	+23	+27		dBm
	RF = 900 MHz, LO = 790 MHz	+19	+23		dBm
	RF = 900 MHz, LO = 1010 MHz	+18	+22		dBm
RF to IF leakage	RF = 900 MHz, LO = 790 MHz		-50		dBm
	RF = 900 MHz, LO = 1010 MHz		-50		dBm
LO to IF leakage	LO = 790 MHz		-45		dBm
	LO = 1010 MHz		-50		dBm
-1dB compression point (mixer bias = 80 mA)		+14	+18		dBm
-1 dB compression point		+10	+14		dBm
1/2 IF product suppression			-75	-70	dBc
Local Oscillator					
LO input frequency		700		1000	MHz
LO input (Note 1)	50 Ω		1.5:1	2.0:1	VSWR
LO level input		-5	0	+5	dBm
Intermediate Frequency					
IF output frequency		50		250	MHz
IF output (Note 1)	50 Ω, IF = 50 MHz to 150 MHz		1.5:1	2.0:1	VSWR
	50 Ω, IF = 110 MHz		1.5:1	2.0:1	VSWR
<p>Note 1: In a 50 Ω system obtained with external matching components on input/output ports. See Figure 10 and Table 6 for matching network configuration and element values.</p> <p>Note 2: Include RF balun and IF transformer losses.</p>					

Table 5. Full Channel Performance
 (+ 25° C, Voltage Supply = ±5 V, LO = 0 dBm, RF Frequency = 900 MHz, IF Frequency = 110 MHz)

Parameter	Test Condition	Min	Typical	Max	Units
RF input (Note 1)			1.5:1	2.0:1	VSWR
NF (Note 2)			3.0	5.5	dB
Gain (Note 3)		11	15		dB
Input IP3 (Note 4)	mixer bias = 80 mA	9	13		dBm
	mixer bias = 55 mA	5.5	9.5		dBm
1 dB compression point (Note 5)	mixer bias = 80 mA	+1	+5		dBm
	mixer bias = 55 mA	-3	+1		dBm
1/2 IF product suppression			-70	-60	dBc
Channel A to B isolation		35	40		dB
LO leakage at RF input			-40	-35	dBm
LO1 to LO2 isolation		35	40		dB
Supply current @ +5.0 V, both channels			340	360	mA
Supply current @ -5.0 V, both channels			10	15	mA

Note 1: In a 50 Ω system obtained with external matching network on LNA and mixer input ports. See Figure 10 and Table 6 for network elements and frequency ranges.

Note 2: Calculated using the following equation: $NF_{Cascaded} = 10 \times \text{Log} \left(10^{\left(\frac{NF_{LNA}}{10} \right)} + \frac{10^{\left(\frac{NF_{Mixer} + Loss_{IRfilter}}{10} \right)} - 1}{10^{\left(\frac{G_{LNA}}{10} \right)}} \right)$

Note 3: Calculated using the following equation: $ConversionGain_{Cascaded} = G_{LNA} - Loss_{IRfilter} + G_{Mixer}$

Note 4: Calculated using the following equation: $IIP3 = 10 \times \text{Log} \left(\frac{1}{10^{\left(\frac{IIP3_{Mixer} - (G_{LNA} - Loss_{IRfilter})}{10} \right)}} + \frac{1}{10^{\left(\frac{IIP3_{LNA}}{10} \right)}} \right)^{-1}$

Note 5: Calculated using the following equation: $P_{1dB,system} = (P_{1dB,Mixer} - (G_{LNA} - Loss_{IRfilter}))$ or $(P_{1dB,LNA})$, whichever is less

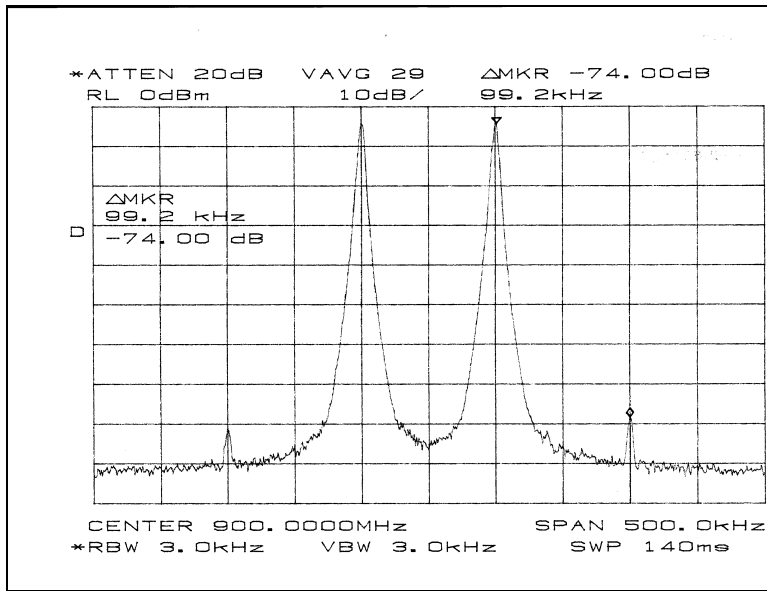

Figure 3. LNA
(IIP3 = +17 dBm, Input Power = -20 dBm)

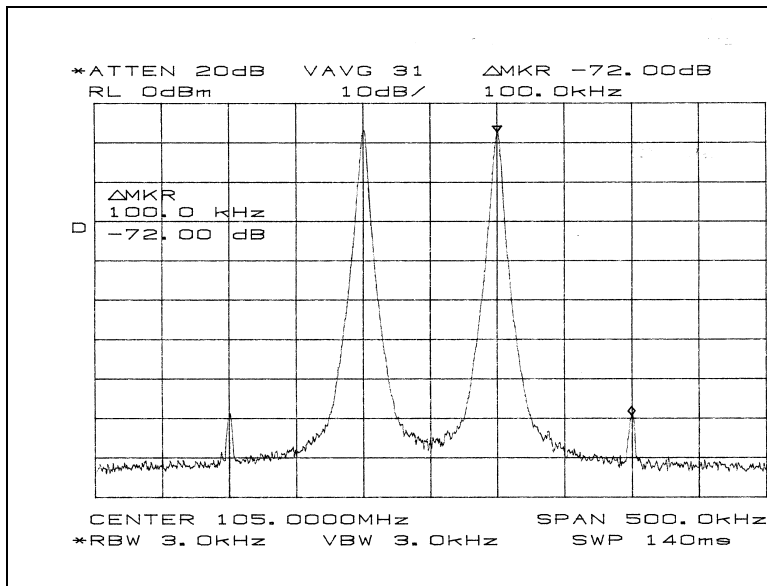

Figure 4. Mixer With High Side LO
(IIP3 = +26 dBm, Input Power = -10 dBm)

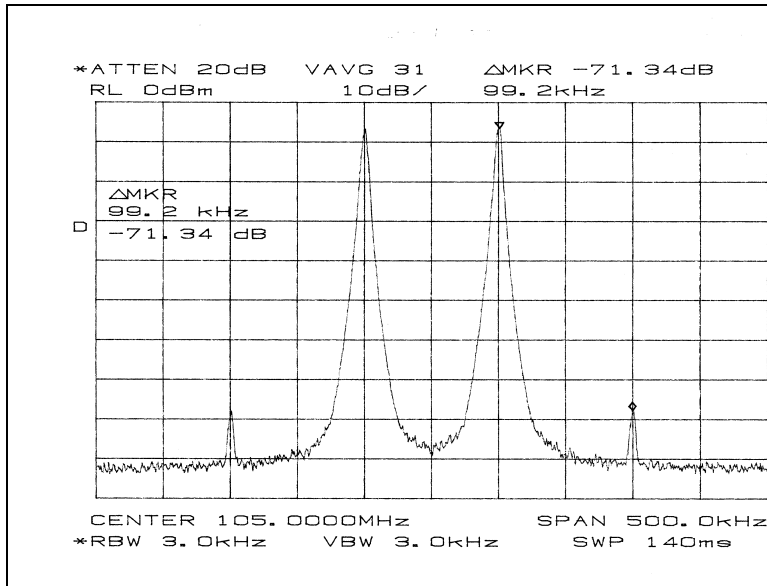

Figure 5. Mixer With Low Side LO
(IIP3 = +25 dBm, Input Power = -10 dBm)

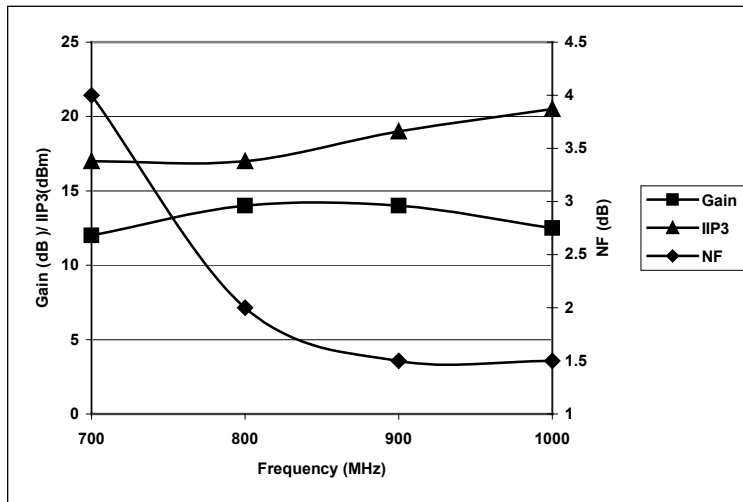

Figure 6. LNA Gain, NF, and IIP3 vs Frequency
(Values Obtained With a 900 MHz Input Match)



Figure 7. Mixer Bias Current vs. Bias Resistor (RA2, RB2)

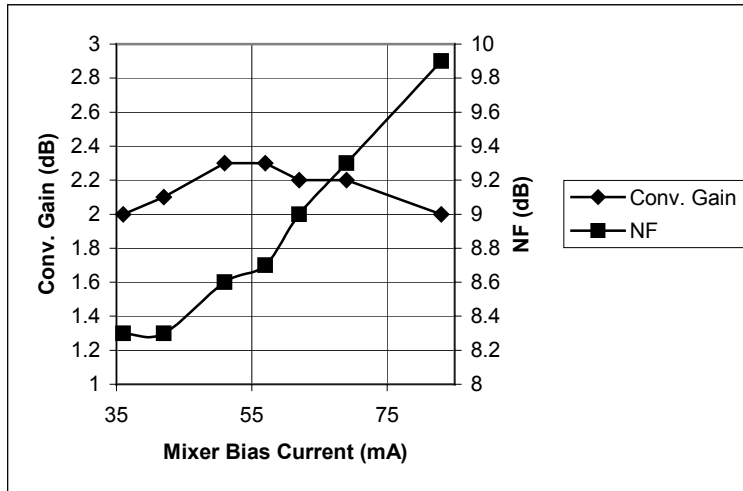

Figure 8. Mixer Conversion Gain and Noise Figure vs. Bias Current

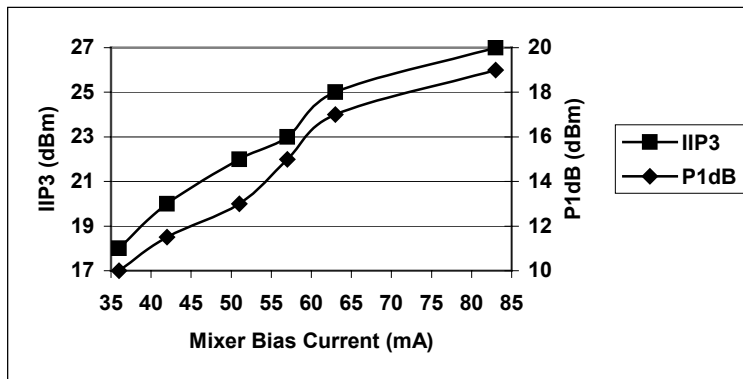

Figure 9. Mixer IIP3 and -1 dB Compression Point vs. Mixer Bias Current

Evaluation Board Description

The CX42053 Evaluation Board is used to test the CX42053 mixer and LNA performance. The CX42053 Evaluation Board schematic diagram is shown in Figure 10. Table 6 contains I/O matching network components used in the schematic. The schematic shows the basic design of the Evaluation Board for the RF range of 800 to 1000 MHz. The IF matching circuitry has been optimized for 60 to 130 MHz. Figure 11 displays the Evaluation Board layout.

Circuit Design Configurations

The following design considerations are general in nature and must be followed regardless of final use or configuration:

1. Paths to ground should be made as short as possible.
2. The downset paddle of the PQFP provides necessary electrical grounding and is the main thermal conduit for heat dissipation. Any printed circuit board using the CX42053 must have sufficient solder mask clearance beneath the IC (i.e., approximately 110 percent of the downset paddle). This provides adequate solder coverage for the downset paddle and minimizes excessive lead standoff. Multiple vias to the grounding layer beneath the device are required for maximum thermal relief.
3. The inclusion of external bypass capacitors on the VSS and VDD voltage inputs of the LNAs and mixers is recommended. The application schematic in Figure 10 shows these capacitors (1000 pF and 12 pF) in shunt with each control switch, as well as the VSS supply. The 1000 pF capacitor serves as a low frequency bypass, while the 12 pF capacitor prevents any RF signals from coupling on to the DC supply voltages. It is recommended that the bypass capacitors be placed as close as possible to the CX42053 for best results.
4. The LNA receives its bias voltage via the LNA output pin. The use of a blocking capacitor (RF short) on the LNA input/output and mixer input is required.
5. Ceramic or wire-wound balanced transformers (baluns) may be used to provide the differential input to the active mixer. The secondary center tap of these baluns provides the DC return path for the mixer bias current. Balun selection criterion should include DC current handling capability, differential phase/amplitude balance, insertion loss, and temperature performance.
6. The application of an image-reject filter between the LNA and mixer is recommended.
7. For proper switching of the control interface circuits, the following conditions must be met:

OFF: $0 \text{ VDC} \leq V_{IN} \leq 0.5 \text{ VDC} @ 30 \mu\text{A}$
 ON: $3.0 \text{ VDC} \leq V_{IN} \leq V_{DD} @ 120 \mu\text{A}$

LNA Testing Procedure

Use the following procedure to set up the CX42053 Evaluation Board for LNA testing. Refer to Figure 12 for guidance:

1. Set all the DIP switches to OFF. For information on the switch settings, refer to Table 7.
2. Connect the CX42053 Evaluation Board to ± 5 VDC power supplies using insulated supply cables. VDD should be set to +5.0 V and VSS to -5.0 V. If available, enable the current limiting function of the power supplies as follows:

+ 5 VDC supply current limit = 200 mA
 -5 VDC supply current limit = 50 mA

Connect red and yellow banana plugs to VDD, a purple plug to VSS, and a black plug to ground. Connect a three-slot plug to the side (JP1) and a two-slot plug to the top (JP2).
3. Connect a signal generator to the LNA A input port (J1). Set the generator to the desired RF frequency at a power level of -20 dBm, but do not enable.
4. Connect a spectrum analyzer to the output port of LNA A (J2).
5. Enable the power supply by turning switches #2 and #4 ON.
6. Enable the RF signal and take measurements.
7. Repeat steps 3 through 6 for LNA B, but use switches #4 and #5 to enable the power supply.

Mixer Testing Procedure

Use the following procedure to set up the CX42053 Evaluation Board for mixer testing. Refer to Figure 13 for guidance:

1. Set all the DIP switches to OFF. For information on the switch settings, refer to Table 7.
2. Connect the CX42053 Evaluation Board to ± 5 VDC power supplies using insulated supply cables. VDD should be set to +5.0 V and VSS to -5.0 V. If available, enable the current limiting function of the power supplies as follows:

+ 5 VDC supply current limit = 200 mA
 -5 VDC supply current limit = 50 mA

Connect red and yellow banana plugs to VDD, a purple plug to VSS, and a black plug to ground. Connect a three-slot plug to the side (JP1) and a two-slot plug to the top (JP2).
3. Connect a signal generator to the LO1 input port (J9). Set the generator to the desired LO frequency at a power level of 0 dBm, but do not enable.

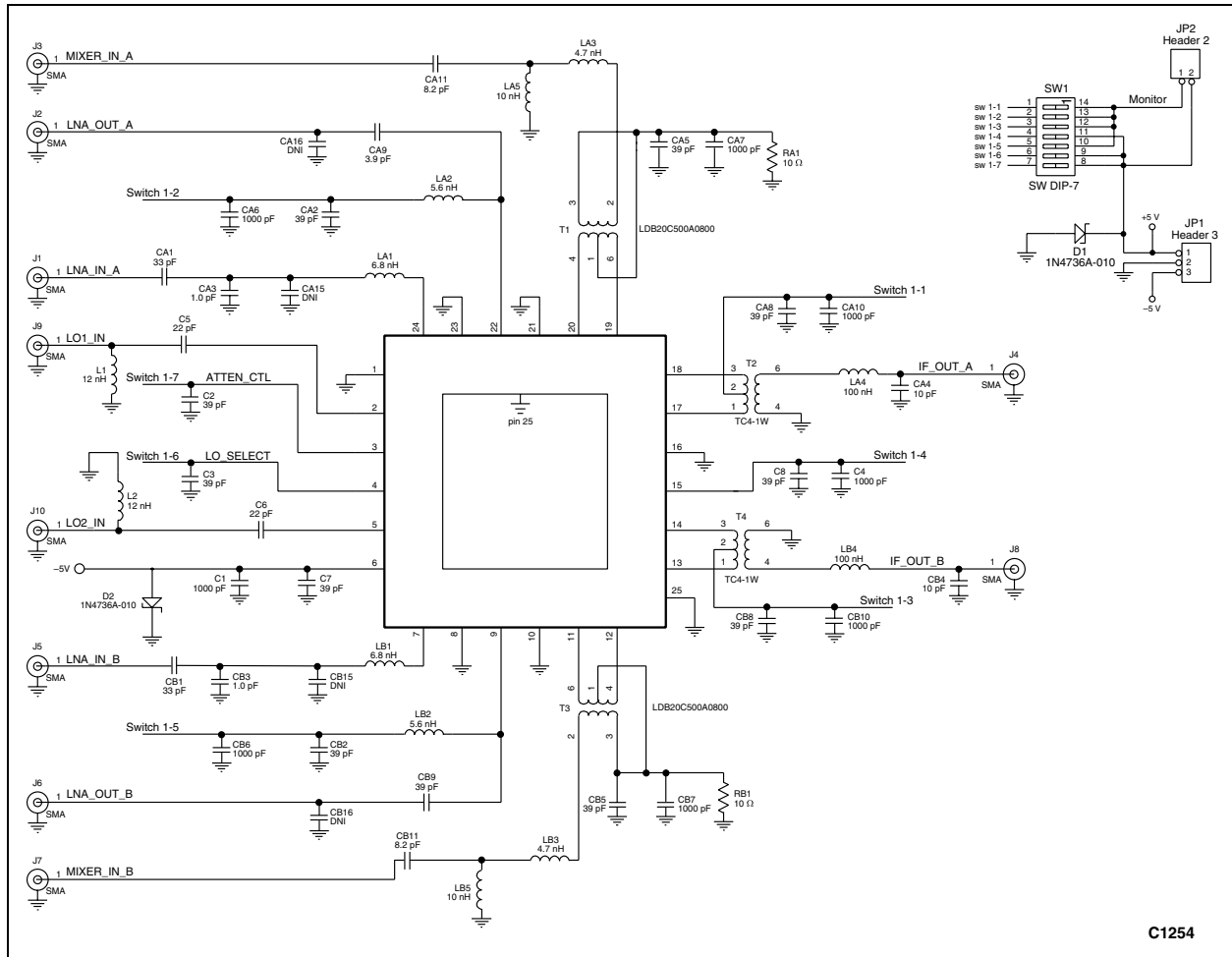

Figure 10. CX42053 Application Schematic

Table 6. Input/Output Matching Network Components for Application Schematic

RF Frequency	LA1, LB1	CA3, CB3	CA9, CB9	CA16, CB16	T1, T2	CA11, CB11	LA5, LB5	LA3, LB3
800-1000 MHz	6.8 nH	1.0 pF	3.9 pF	DNI	LDB20C500A800	4.7 pF	15 nH	33 nH
700-800 MHz (Note 1)	6.8 nH	1.0 pF	3.9 pF	DNI	LDB20C500A800	8.2 pF	10 nH	4.7 pF
IF Frequency	LA4, LB4	CA4, CB4						
40-80 MHz (Note 2)	150 nH	10 pF						
70-200 MHz	100 nH	10 pF						
<p>Note 1: Standard Evaluation Kit TW11-D222 is optimized for the 850 to 1000 MHz frequency range. The schematic diagram shown in Figure 10 applies to Evaluation Kit TW11-D222.</p> <p>Note 2: For the stated values, CA4 and CB4 need to be moved to the side of LA4 and LB4 closest to the CX42053.</p>								

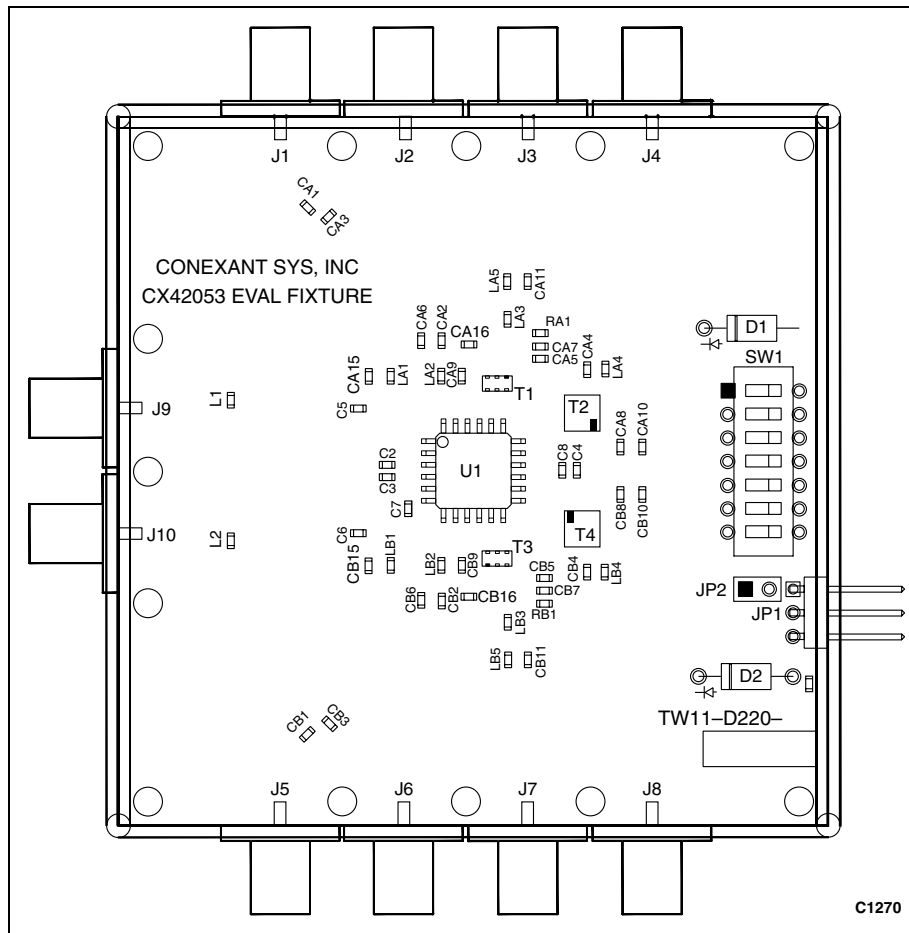

Figure 11. CX42053 Evaluation Board Layout

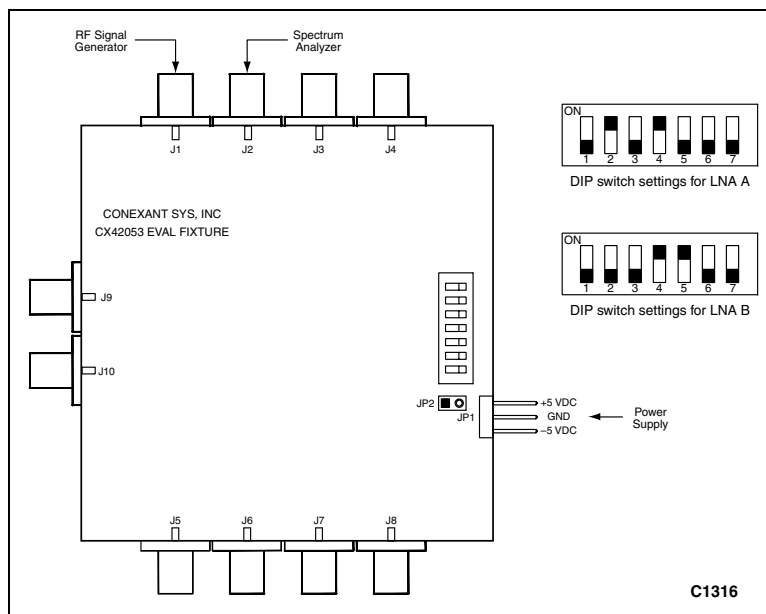

Figure 12. CX42053 Evaluation Board LNA Testing Configuration

Table 7. CX42053 Switch Pack Description

Switch	Name	Description
#1	V _{MIX_A}	ON enables mixer A
#2	V _{LNA_A}	ON enables LNA A
#3	V _{MIX_B}	ON enables mixer B
#4	V _{VDD}	ON enables VDD
#5	V _{LNA_B}	ON enables LNA B
#6	V _{LOSELECT}	ON selects LO1, OFF selects LO2
#7	V _{ATTENUATOR}	ON enables attenuation

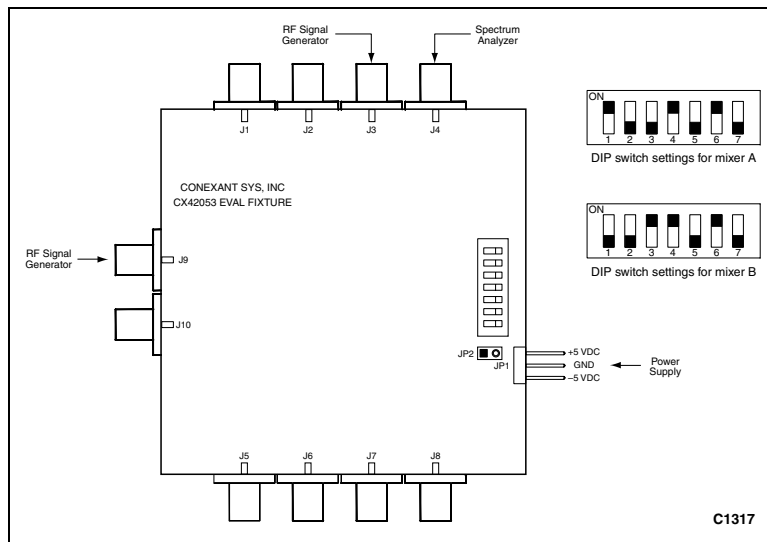

Figure 13. CX42053 Evaluation Board Mixer Testing Configuration

4. Connect a signal generator to the Mixer A input port (J3). Set the generator to the desired RF frequency at a power level of 0 dBm, but do not enable.
5. Connect a spectrum analyzer to the output port of Mixer A (J4).
6. Enable the power supply by turning switches #1 and #4 ON.
7. Enable LO1 by turning switch #6 ON.
8. Enable the LO signal, then enable the RF signal and take measurements.
9. Repeat steps 4 through 8 for mixer B, but use switches #3 and #4 to enable the power supply. If LO2 is desired, turn switch #6 OFF and connect the LO signal generator to the LO2 input port (J10).

Caution: *If any of the input signals exceed the rated maximum values, the CX42053 Evaluation Board can be permanently damaged.*

Package Dimensions

Figure 14 shows the package dimensions for the 24-pin CX42053 PQFP and Figure 15 provides the tape and reel dimensions.

Package and Handling Information

Since the device package is sensitive to moisture absorption, it is baked and vacuum packed before shipping. Instructions on the shipping container label regarding exposure to moisture

after the container seal is broken must be followed. Otherwise, problems related to moisture absorption may occur when the part is subjected to high temperature during solder assembly.

If the part is attached in a reflow oven, the temperature ramp rate should not exceed 10 °C per second. Maximum temperature should not exceed 225 °C and the time spent at a temperature that exceeds 210 °C should be limited to less than 10 seconds. If the part is manually attached, precaution should be taken to ensure that the part is not subjected to a temperature that exceeds 300 °C for more than 10 seconds.

Care must be taken when attaching this product, whether it is done manually or in a production solder reflow environment. For additional details on both attachment techniques, precautions, and recommended handling procedures, refer to the Conexant document *Solder Reflow Application Note*, document number 101536.

Production quantities of this product are shipped in a standard tape and reel format. For packaging details, refer to the Conexant document *Tape and Reel Information Application Note*, document number 101568.

Electro-Static Discharge (ESD) Sensitivity

The CX42053 is a static-sensitive electronic device. Do not operate or store near strong electrostatic fields. Take proper ESD precautions.

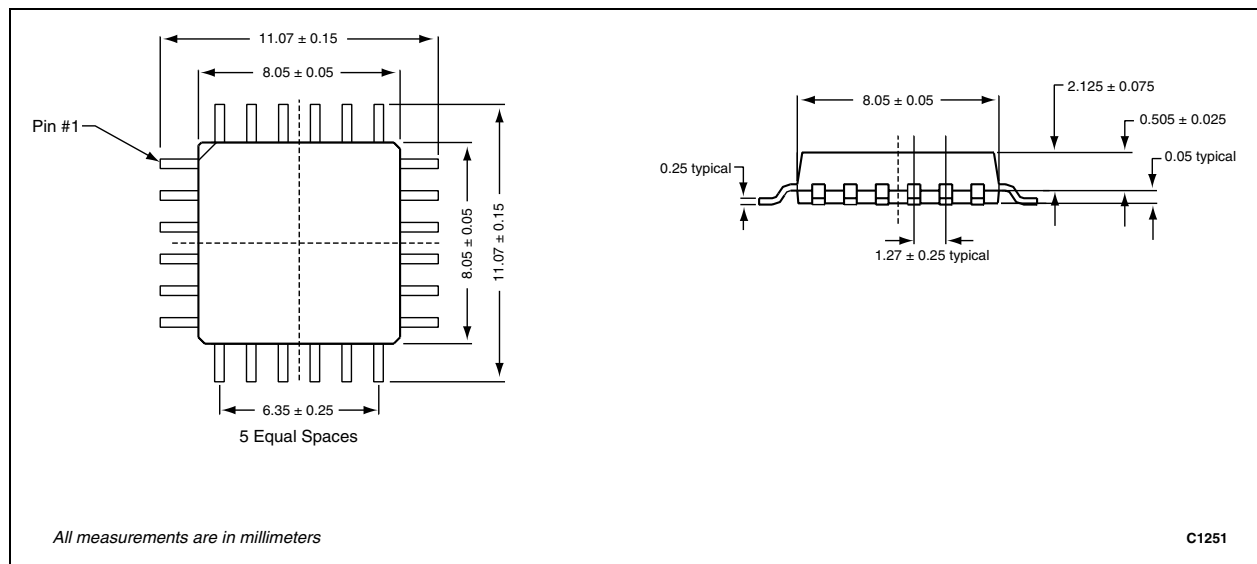

Figure 14. CX42053 24-Pin PQFP Package Dimension Drawing

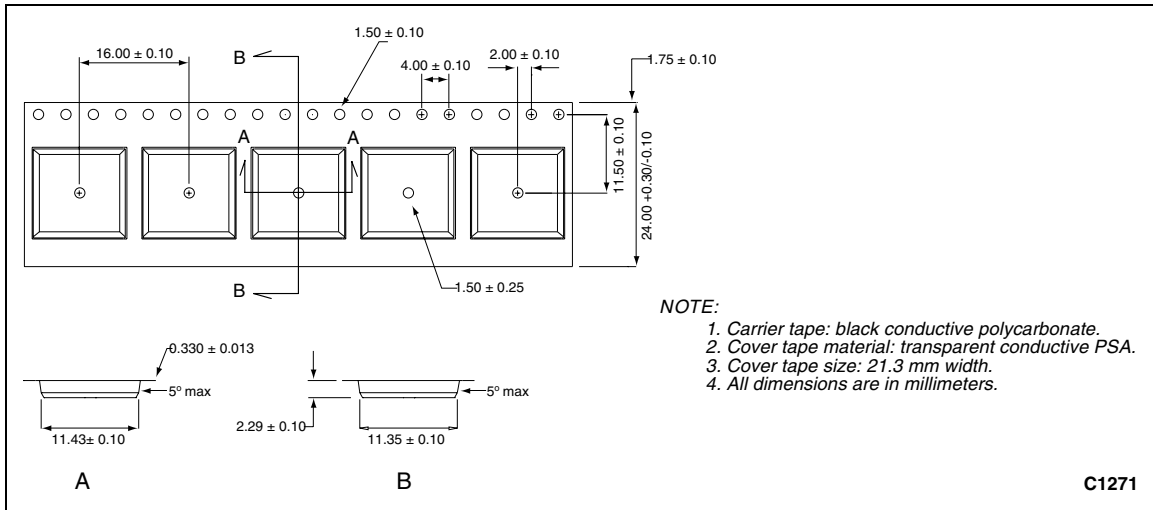

Figure 15. CX42053 24-Pin PQFP Tape and Reel Dimensions

Ordering Information

Model Name	Ordering Part Number	Evaluation Kit Part Number
CX42053 700-1000 MHz Receiver Front End/Downconverter	CX42053-11	TW11-D222

© 2002, Conexant Systems, Inc. All Rights Reserved.

Information in this document is provided in connection with Conexant Systems, Inc. ("Conexant") products. These materials are provided by Conexant as a service to its customers and may be used for informational purposes only. Conexant assumes no responsibility for errors or omissions in these materials. Conexant may make changes to specifications and product descriptions at any time, without notice. Conexant makes no commitment to update the information and shall have no responsibility whatsoever for conflicts or incompatibilities arising from future changes to its specifications and product descriptions.

No license, express or implied, by estoppel or otherwise, to any intellectual property rights is granted by this document. Except as provided in Conexant's Terms and Conditions of Sale for such products, Conexant assumes no liability whatsoever.

THESE MATERIALS ARE PROVIDED "AS IS" WITHOUT WARRANTY OF ANY KIND, EITHER EXPRESS OR IMPLIED, RELATING TO SALE AND/OR USE OF CONEXANT PRODUCTS INCLUDING LIABILITY OR WARRANTIES RELATING TO FITNESS FOR A PARTICULAR PURPOSE, CONSEQUENTIAL OR INCIDENTAL DAMAGES, MERCHANTABILITY, OR INFRINGEMENT OF ANY PATENT, COPYRIGHT OR OTHER INTELLECTUAL PROPERTY RIGHT. CONEXANT FURTHER DOES NOT WARRANT THE ACCURACY OR COMPLETENESS OF THE INFORMATION, TEXT, GRAPHICS OR OTHER ITEMS CONTAINED WITHIN THESE MATERIALS. CONEXANT SHALL NOT BE LIABLE FOR ANY SPECIAL, INDIRECT, INCIDENTAL, OR CONSEQUENTIAL DAMAGES, INCLUDING WITHOUT LIMITATION, LOST REVENUES OR LOST PROFITS, WHICH MAY RESULT FROM THE USE OF THESE MATERIALS.

Conexant products are not intended for use in medical, lifesaving or life sustaining applications. Conexant customers using or selling Conexant products for use in such applications do so at their own risk and agree to fully indemnify Conexant for any damages resulting from such improper use or sale.

The following are trademarks of Conexant Systems, Inc.: Conexant™, the Conexant C symbol, and "What's Next in Communications Technologies"™. Product names or services listed in this publication are for identification purposes only, and may be trademarks of third parties. Third-party brands and names are the property of their respective owners.

Additional information, posted at www.conexant.com, is incorporated by reference.

Reader Response: Conexant strives to produce quality documentation and welcomes your feedback. Please send comments and suggestions to tech.pubs@conexant.com. For technical questions, contact your local Conexant sales office or field applications engineer.

www.conexant.com

General Information:

U.S. and Canada: (800) 854-8099

International: (949) 483-6996

Headquarters – Newport Beach

4311 Jamboree Rd.

Newport Beach, CA 92660-3007



CONEXANT™

What's next in communications technologies