

SYNCHRONOUS DRAM MODULE

MT5LSDT472A

For the latest data sheet revisions, please refer to the Micron
Web site: www.micron.com/mti/msp/html/datasheet.html

FEATURES

- PC100-compliant; includes CONCURRENT AUTO PRECHARGE
- JEDEC-standard 168-pin, dual in-line memory module (DIMM)
- Utilizes 100 MHz and 125 MHz SDRAM components
- Nonbuffered
- 32MB (4 Meg x 72)
- Single +3.3V ±0.3V power supply
- Fully synchronous; all signals registered on positive edge of system clock
- Internal pipelined operation; column address can be changed every clock cycle
- Internal SDRAM banks for hiding row access/precharge
- Programmable burst lengths: 1, 2, 4, 8 or full page
- Auto Precharge and Auto Refresh Modes
- Self Refresh Mode
- 64ms, 4,096-cycle refresh
- LVTTTL-compatible inputs and outputs
- Serial presence-detect (SPD)
- Two-clock WRITE recovery (t_{WR}) version; one-clock t_{WR} not supported

OPTIONS

- Package
168-pin DIMM (gold) G
- Frequency/CAS Latency
100 MHz/CL = 3 (8ns, 125 MHz SDRAMs) -10C
100 MHz/CL = 3 (8ns, 125 MHz SDRAMs) -10B
66 MHz/CL = 2 (10ns, 100 MHz SDRAMs) -662
- Component Revision Designator
Alpha character Factory Defined
- Printed Circuit Board Revision Designator
Numeric character Factory Defined

MARKING

KEY SDRAM COMPONENT TIMING PARAMETERS

MODULE MARKING	SPEED GRADE	CAS LATENCY	ACCESS TIME	SETUP TIME	HOLD TIME
-10B/-10C	-8B/-8C	3	6ns	2ns	1ns
-662	-10	2	9ns	3ns	1ns

NOTE: Pin symbols in parentheses are not used on these modules but may be used for other modules in this product family. They are for reference only.

PIN ASSIGNMENT (Front View)

168-Pin DIMM

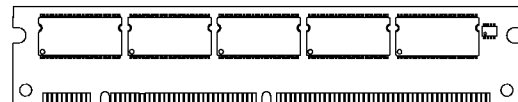

PIN	SYMBOL	PIN	SYMBOL	PIN	SYMBOL	PIN	SYMBOL
1	Vss	43	Vss	85	Vss	127	Vss
2	DQ0	44	DNU	86	DQ32	128	CKE0
3	DQ1	45	S2#	87	DQ33	129	NC (S3#)
4	DQ2	46	DQMB2	88	DQ34	130	DQMB6
5	DQ3	47	DQMB3	89	DQ35	131	DQMB7
6	VDD	48	DNU	90	VDD	132	NC (A13)
7	DQ4	49	VDD	91	DQ36	133	VDD
8	DQ5	50	NC	92	DQ37	134	NC
9	DQ6	51	NC	93	DQ38	135	NC
10	DQ7	52	CB2	94	DQ39	136	CB6
11	DQ8	53	CB3	95	DQ40	137	CB7
12	Vss	54	Vss	96	Vss	138	Vss
13	DQ9	55	DQ16	97	DQ41	139	DQ48
14	DQ10	56	DQ17	98	DQ42	140	DQ49
15	DQ11	57	DQ18	99	DQ43	141	DQ50
16	DQ12	58	DQ19	100	DQ44	142	DQ51
17	DQ13	59	VDD	101	DQ45	143	VDD
18	VDD	60	DQ20	102	VDD	144	DQ52
19	DQ14	61	NC	103	DQ46	145	NC
20	DQ15	62	NC	104	DQ47	146	NC
21	CB0	63	NC (CKE1)	105	CB4	147	NC
22	CB1	64	Vss	106	CB5	148	Vss
23	Vss	65	DQ21	107	Vss	149	DQ53
24	NC	66	DQ22	108	NC	150	DQ54
25	NC	67	DQ23	109	NC	151	DQ55
26	VDD	68	Vss	110	VDD	152	Vss
27	WE#	69	DQ24	111	CAS#	153	DQ56
28	DQMB0	70	DQ25	112	DQMB4	154	DQ57
29	DQMB1	71	DQ26	113	DQMB5	155	DQ58
30	SO#	72	DQ27	114	NC (S1#)	156	DQ59
31	DNU	73	VDD	115	RAS#	157	VDD
32	Vss	74	DQ28	116	Vss	158	DQ60
33	A0	75	DQ29	117	A1	159	DQ61
34	A2	76	DQ30	118	A3	160	DQ62
35	A4	77	DQ31	119	A5	161	DQ63
36	A6	78	Vss	120	A7	162	Vss
37	A8	79	CK2	121	A9	163	NC (CK3)
38	A10	80	NC	122	BA0	164	NC
39	BA1	81	NC/WP*	123	A11	165	SA0
40	VDD	82	SDA	124	VDD	166	SA1
41	VDD	83	SCL	125	NC (CK1)	167	SA2
42	CK0	84	VDD	126	NC (A12)	168	VDD

*WP applies to -10B/-10C versions only

PART NUMBERS

PART NUMBER	CONFIGURATION	SYSTEM BUS SPEED
MT5LSDT472AG-10C	4 Meg x 72	100 MHz
MT5LSDT472AG-10B	4 Meg x 72	100 MHz
MT5LSDT472AG-662	4 Meg x 72	66 MHz

NOTE: All part numbers end with a two-place code (not shown), designating component and PCB revisions. Consult factory for current revision codes. Example: MT5LSDT472AG-10CB1.

GENERAL DESCRIPTION

The MT5LSDT472A is a high-speed CMOS, dynamic random-access, 32MB memory organized in a x72 configuration. This module uses internally configured quad-bank SDRAMs with a synchronous interface (all signals are registered on the positive edge of the clock signals CK0, CK2).

Read and write accesses to the SDRAM module are burst oriented; accesses start at a selected location and continue for a programmed number of locations in a programmed sequence. Accesses begin with the registration of an ACTIVE command, which is then followed by a READ or WRITE command. The address bits registered coincident with the ACTIVE command are used to select the bank and row to be accessed (BA0, BA1 select the bank, A0-A11 select the row). The address bits registered coincident with the

READ or WRITE command are used to select the starting column location for the burst access.

The module provides for programmable READ or WRITE burst lengths of 1, 2, 4 or 8 locations, or the full page, with a burst terminate option. An AUTO PRECHARGE function may be enabled to provide a self-timed row precharge that is initiated at the end of the burst sequence.

The module uses an internal pipelined architecture to achieve high-speed operation. This architecture is compatible with the 2n rule of prefetch architectures, but it also allows the column address to be changed on every clock cycle to achieve a high-speed, fully random access. Precharging one bank while accessing one of the other three banks will hide the precharge cycles and provide seamless, high-speed, random-access operation.

The module is designed to operate in 3.3V, low-power memory systems. An auto refresh mode is provided, along with a power-saving, power-down mode. All inputs and outputs are LVTTTL-compatible.

SDRAM modules offer substantial advances in DRAM operating performance, including the ability to synchronously burst data at a high data rate with automatic column-address generation, the ability to interleave between internal banks in order to hide precharge time and the capability to randomly change column addresses on each clock cycle during a burst access. For more information regarding the SDRAM operation, refer to the 64Mb: x4, x8, x16 SDRAM data sheet.

**FUNCTIONAL BLOCK DIAGRAM
MT5LSDT472A (32MB)**

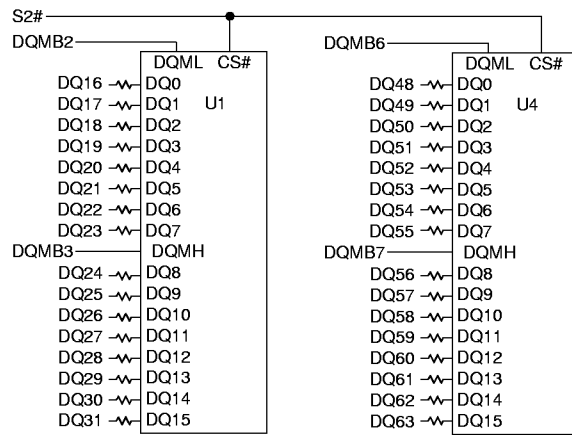
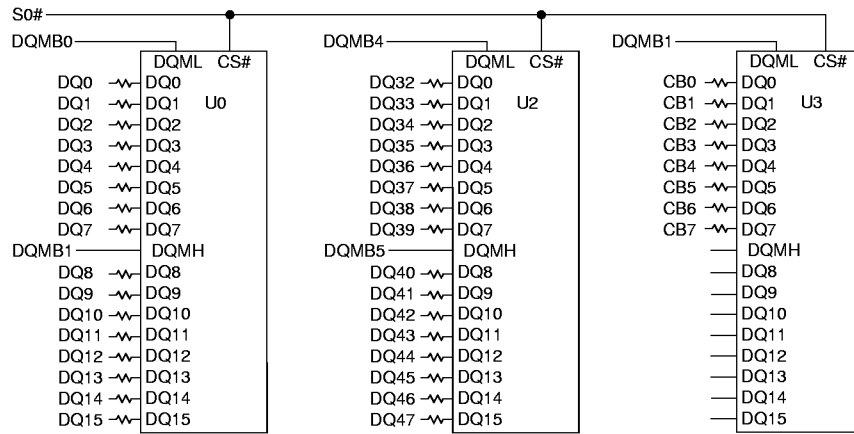

RAS# → RAS#: SDRAMs U0-U4
 CAS# → CAS#: SDRAMs U0-U4
 CE# → CE#: SDRAMs U0-U4
 WE# → WE#: SDRAMs U0-U4
 A0-A11 → A0-A11: SDRAMs U0-U4
 BA0-1 → BA0-1: SDRAMs U0-U4

V_{DD} → SDRAMs U0-U4
 V_{SS} → SDRAMs U0-U4

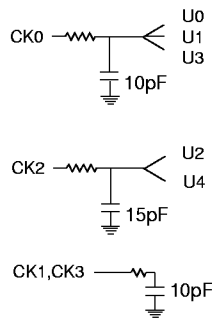
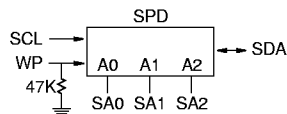

NOTE: All resistor values are 10 ohms.

U0-U4 = MT48LC4M16A2TG SDRAMs

PIN DESCRIPTIONS

PIN NUMBERS	SYMBOL	TYPE	DESCRIPTION
115, 111, 27	RAS#, CAS#, WE#	Input	Command Inputs: RAS#, CAS# and WE# (along with S0#, S2#) define the command being entered.
42, 79	CK0, CK2	Input	Clock: CK0, CK2 are driven by the system clock. All SDRAM input signals are sampled on the positive edge of CK. CK also increments the internal burst counter and controls the output registers.
128	CKE0	Input	Clock Enable: CKE0 activates (HIGH) and deactivates (LOW) the CK0, CK2 signals. Deactivating the clock provides PRECHARGE POWER-DOWN and SELF REFRESH operation (all banks idle), ACTIVE POWER-DOWN (row ACTIVE in any bank), or CLOCK SUSPEND operation (burst access in progress). CKE0 is synchronous except after the device enters power-down and self refresh modes, where CKE0 becomes asynchronous until after exiting the same mode. The input buffers, including CK0, CK2, are disabled during power-down and self refresh modes, providing low standby power.
30, 45	S0#, S2#	Input	Chip Select: S0# and S2# enable (registered LOW) and disable (registered HIGH) the command decoder. All commands are masked when S0# and S2# are registered HIGH. S0# and S2# are considered part of the command code.
28-29, 46-47, 112-113, 130-131	DQMB0-DQMB7	Input	Input/Output Mask: DQMB is an input mask signal for write accesses and an output enable signal for read accesses. Input data is masked when DQMB is sampled HIGH during a WRITE cycle. The output buffers are placed in a High-Z state (two-clock latency) when DQMB is sampled HIGH during a READ cycle.
39, 122	BA1, BA0	Input	Bank Address: BA0 and BA1 define to which bank the ACTIVE, READ, WRITE or PRECHARGE command is being applied.
33-38, 117-121, 123	A0-A11	Input	Address Inputs: A0-A11 are sampled during the ACTIVE command (row-address A0-A11) and READ/WRITE command (column-address A0-A7, with A10 defining AUTO PRECHARGE) to select one location out of the memory array in the respective bank. A10 is sampled during a PRECHARGE command to determine if all banks are to be precharged (A10 HIGH) or bank selected by BA0, BA1 (LOW). The address inputs also provide the op-code during a LOAD MODE REGISTER command.
2-5, 7-11, 13-17, 19-20, 55-58, 60, 65-67, 69-72, 74-77, 86-89, 91-95, 97-101, 103-104, 139-142, 144, 149-151, 153-156, 158-161	DQ0-DQ63	Input/Output	Data I/O: Data bus.

PIN DESCRIPTIONS (continued)

PIN NUMBERS	SYMBOL	TYPE	DESCRIPTION
21, 22, 52, 53, 105, 106 136, 137	CB0-CB7	Input/ Output	Check Bits.
6, 18, 26, 40, 41, 49, 59, 73, 84, 90, 102, 110, 124, 133, 143, 157, 168	V _{DD}	Supply	Power Supply: +3.3V ±0.3V.
1, 12, 23, 32, 43, 54, 64, 68, 78, 85, 96, 107, 116, 127, 138, 148, 152, 162	V _{SS}	Supply	Ground.
81	WP	Input	Write Protect: Serial presence-detect hardware write protect. Applies to -10B/-10C versions only.
82	SDA	Input/Output	Serial Presence-Detect Data: SDA is a bidirectional pin used to transfer addresses and data into and data out of the presence-detect portion of the module.
83	SCL	Input	Serial Clock for Presence-Detect: SCL is used to synchronize the presence-detect data transfer to and from the module.
165-167	SA0-SA2	Input	Presence-Detect Address Inputs: These pins are used to configure the presence-detect device.
31, 44, 48	DNU	–	Do Not Use: These pins are not connected on this module but are assigned pins on the compatible DRAM version.

SERIAL PRESENCE-DETECT OPERATION

This module incorporates serial presence-detect (SPD). The SPD function is implemented using a 2,048-bit EEPROM. This nonvolatile storage device contains 256 bytes. The first 128 bytes can be programmed by Micron to identify the module type and various SDRAM organization and timing parameters. The remaining 128 bytes of storage are available for use by the customer. System READ/WRITE operations between the master (system logic) and the slave EEPROM device (DIMM) occur via a standard IIC bus using the DIMM's SCL (clock) and SDA (data) signals, together with SA(2:0), which provide eight unique DIMM/EEPROM addresses.

SPD CLOCK AND DATA CONVENTIONS

Data states on the SDA line can change only during SCL LOW. SDA state changes during SCL HIGH are reserved for indicating start and stop conditions (Figures 1 and 2).

SPD START CONDITION

All commands are preceded by the start condition, which is a HIGH-to-LOW transition of SDA when SCL is HIGH. The SPD device continuously monitors the SDA and SCL lines for the start condition and will not respond to any command until this condition has been met.

SPD STOP CONDITION

All communications are terminated by a stop condition, which is a LOW-to-HIGH transition of SDA when SCL is HIGH. The stop condition is also used to place the SPD device into standby power mode.

SPD ACKNOWLEDGE

Acknowledge is a software convention used to indicate successful data transfers. The transmitting device, either master or slave, will release the bus after transmitting eight bits. During the ninth clock cycle, the receiver will pull the SDA line LOW to acknowledge that it received the eight bits of data (Figure 3).

The SPD device will always respond with an acknowledge after recognition of a start condition and its slave address. If both the device and a WRITE operation have been selected, the SPD device will respond with an acknowledge after the receipt of each subsequent eight bit word. In the read mode the SPD device will transmit eight bits of data, release the SDA line and monitor the line for an acknowledge. If an acknowledge is detected and no stop condition is generated by the master, the slave will continue to transmit data. If an acknowledge is not detected, the slave will terminate further data transmissions and await the stop condition to return to standby power mode.

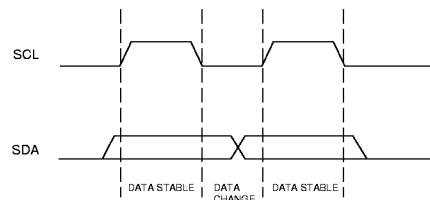

**Figure 1
DATA VALIDITY**

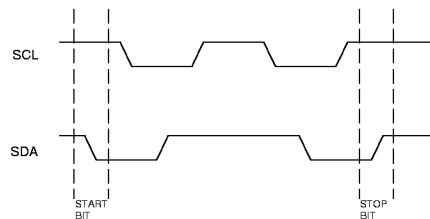

**Figure 2
DEFINITION OF START AND STOP**

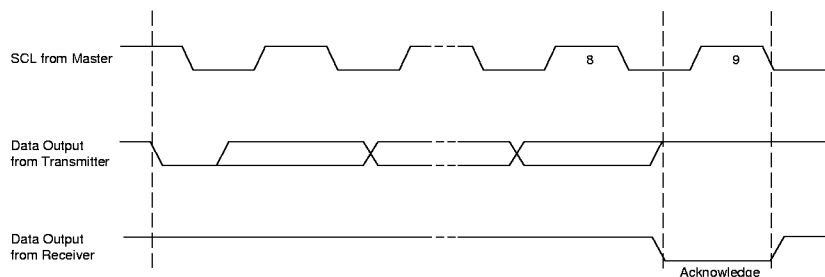

**Figure 3
ACKNOWLEDGE RESPONSE FROM RECEIVER**

SERIAL PRESENCE-DETECT MATRIX

BYTE	DESCRIPTION	ENTRY (VERSION)	SYMBOL	BIT7	BIT6	BIT5	BIT4	BIT3	BIT2	BIT1	BIT0	HEX
0	NUMBER OF BYTES USED BY MICRON	128		1	0	0	0	0	0	0	0	80
1	TOTAL NUMBER OF SPD MEMORY BYTES	256		0	0	0	0	1	0	0	0	08
2	MEMORY TYPE	SDRAM		0	0	0	0	0	1	0	0	04
3	NUMBER OF ROW ADDRESSES	12		0	0	0	0	1	1	0	0	0C
4	NUMBER OF COLUMN ADDRESSES	8		0	0	0	0	1	0	0	0	08
5	NUMBER OF BANKS	1		0	0	0	0	0	0	0	1	01
6	MODULE DATA WIDTH	72		0	1	0	0	0	0	0	0	48
7	MODULE DATA WIDTH (continued)	0		0	0	0	0	0	0	0	0	00
8	MODULE VOLTAGE INTERFACE LEVELS	LVTTL		0	0	0	0	0	0	0	1	01
9	SDRAM CYCLE TIME (CAS LATENCY = 3)	8 (-10B/C) 10 (-662)	^t CK	1 1	0 0	0 1	0 0	0 0	0 0	0 0	0 0	80 A0
10	SDRAM ACCESS FROM CLOCK (CAS LATENCY = 3)	6 (-10B/C) 7 (-662)	^t AC	0 0	1 1	1 1	0 1	0 0	0 0	0 0	0 0	60 70
11	MODULE CONFIGURATION TYPE	ECC		0	0	0	0	0	0	0	0	02
12	REFRESH RATE/TYPE	15.6µs/SELF		1	0	0	0	0	0	0	0	80
13	SDRAM WIDTH (PRIMARY SDRAM)	16		0	0	0	1	0	0	0	0	10
14	ERROR-CHECKING SDRAM DATA WIDTH	16		0	0	0	1	0	0	0	0	10
15	MINIMUM CLOCK DELAY FROM BACK-TO-BACK RANDOM COLUMN ADDRESSES	1	^t CCD	0	0	0	0	0	0	0	1	01
16	BURST LENGTHS SUPPORTED	1, 2, 4, 8, PAGE		1	0	0	0	1	1	1	1	8F
17	NUMBER OF BANKS ON SDRAM DEVICE	4		0	0	0	0	0	1	0	0	04
18	CAS LATENCIES SUPPORTED	2, 3		0	0	0	0	0	1	1	0	06
19	CS LATENCY	0		0	0	0	0	0	0	0	1	01
20	WE LATENCY	0		0	0	0	0	0	0	0	1	01
21	SDRAM MODULE ATTRIBUTES	NONBUFFERED		0	0	0	0	0	0	0	0	00
22	SDRAM DEVICE ATTRIBUTES: GENERAL	0E		0	0	0	0	1	1	1	0	0E
23	SDRAM CYCLE TIME (CAS LATENCY = 2)	12 (-10B/C) 15 (-662)	^t CK	1 1	1 1	0 1	0 1	0 0	0 0	0 0	0 0	C0 F0
24	SDRAM ACCESS FROM CLK (CAS LATENCY = 2)	9	^t AC	1	0	0	1	0	0	0	0	90
25	SDRAM CYCLE TIME (CAS LATENCY = 1)	-	^t CK	0	0	0	0	0	0	0	0	00
26	SDRAM ACCESS FROM CLK (CAS LATENCY = 1)	-	^t AC	0	0	0	0	0	0	0	0	00
27	MINIMUM ROW PRECHARGE TIME	20 (-10C) 24 (-10B) 30 (-662)	^t RP	0 0 0	0 0 0	0 0 0	1 1 1	0 1 1	1 0 1	0 0 1	0 0 0	14 18 1E
28	MINIMUM ROW ACTIVE TO ROW ACTIVE	20	^t RRD	0	0	0	1	0	1	0	0	14
29	MINIMUM RAS# TO CAS# DELAY	20 (-10B/C) 30 (-662)	^t RCD	0 0	0 0	0 0	1 1	0 1	1 1	0 1	0 0	14 1E
30	MINIMUM RAS# PULSE WIDTH	50 (-10B/C) 60 (-662)	^t RAS	0 0	0 0	1 1	1 1	0 1	0 1	1 0	0 0	32 3C
31	MODULE BANK DENSITY	32MB		0	0	0	0	1	0	0	0	08
32	COMMAND AND ADDRESS SETUP TIME	2 (-10B/C) 3 (-662)	^t AS, ^t CMS	0 0	0 0	1 1	0 1	0 0	0 0	0 0	0 0	20 30

NOTE: 1. "1"/"0": Serial Data, "driven to HIGH"/"driven to LOW."

SERIAL PRESENCE-DETECT MATRIX (continued)

BYTE	DESCRIPTION	ENTRY (VERSION)	SYMBOL	BIT7	BIT6	BIT5	BIT4	BIT3	BIT2	BIT1	BIT0	HEX
33	COMMAND AND ADDRESS HOLD TIME	1 (-10B/C/-662)	^t AH, ^t CMH	0	0	0	1	0	0	0	0	10
34	DATA SIGNAL INPUT SETUP TIME	2 (-10B/C) 3 (-662)	^t DS	0 0	0 0	1 1	0 1	0 0	0 0	0 0	0 0	20 30
35	DATA SIGNAL INPUT HOLD TIME	1 (-10B/C/-662)	^t DH	0	0	0	1	0	0	0	0	10
36-61	RESERVED			0	0	0	0	0	0	0	0	00
62	SPD REVISION	1.2 (-10B/C/-662)		0	0	0	1	0	0	1	0	12
63	CHECKSUM FOR BYTES 0-62	-10C -10B -662		0 0 1	1 1 1	0 0 1	0 1 0	1 0 1	1 0 1	1 0 0	0 0 0	4E 52 EC
64	MANUFACTURER'S JEDEC ID CODE	MICRON		0	0	1	0	1	1	0	0	2C
65-71	MANUFACTURER'S JEDEC ID CODE (CONT.)			1	1	1	1	1	1	1	1	FF
72	MANUFACTURING LOCATION			0 0 0 0 0 0	0 0 0 0 0 0	0 0 0 0 0 0	0 0 0 0 0 0	0 0 0 1 0 1	0 0 1 0 1 1	0 1 1 0 1 0	01 02 03 04 05 06	
73-90	MODULE PART NUMBER (ASCII)			x	x	x	x	x	x	x	x	x
91	PCB IDENTIFICATION CODE	1 2 3 4		0 0 0 0	0 0 0 0	0 0 0 0	0 0 0 0	0 0 0 0	0 0 0 1	0 1 1 0	1 0 1 0	01 02 03 04
92	IDENTIFICATION CODE (CONT.)	0		0	0	0	0	0	0	0	0	00
93	YEAR OF MANUFACTURE IN BCD			x	x	x	x	x	x	x	x	x
94	WEEK OF MANUFACTURE IN BCD			x	x	x	x	x	x	x	x	x
95-98	MODULE SERIAL NUMBER			x	x	x	x	x	x	x	x	x
99-125	MANUFACTURER-SPECIFIC DATA (RSVD)			-	-	-	-	-	-	-	-	-
126	SYSTEM FREQUENCY	100 MHz (-10B/C) 66 MHz (-662)		0 0	1 1	1 1	0 0	0 0	1 1	0 1	0 0	64 66
127	SDRAM COMPONENT AND CLOCK DETAIL	-10B/C -662		1 1	0 0	1 1	0 0	1 1	1 1	0 1	1 1	AD AF

NOTE: 1. "1"/"0": Serial Data, "driven to HIGH"/"driven to LOW."
2. x = Variable Data.

COMMANDS

Truth Table 1 provides a general reference of available commands. For a more detailed description of commands and operations, refer to the 64Mb: x4, x8, x16 SDRAM data sheet.

TRUTH TABLE 1 – Commands and DQMB Operation

(Notes: 1)

NAME (FUNCTION)	CS#	RAS#	CAS#	WE#	DQMB	ADDR	DQs	NOTES
COMMAND INHIBIT (NOP)	H	X	X	X	X	X	X	
NO OPERATION (NOP)	L	H	H	H	X	X	X	
ACTIVE (Select bank and activate row)	L	L	H	H	X	Bank/Row	X	3
READ (Select bank and column, and start READ burst)	L	H	L	H	X	Bank/Col	X	4
WRITE (Select bank and column, and start WRITE burst)	L	H	L	L	X	Bank/Col	Valid	4
BURST TERMINATE	L	H	H	L	X	X	Active	
PRECHARGE (Deactivate row in bank or banks)	L	L	H	L	X	Code	X	5
AUTO REFRESH or SELF REFRESH (Enter self refresh mode)	L	L	L	H	X	X	X	6, 7
LOAD MODE REGISTER	L	L	L	L	X	Op-code	X	2
Write Enable/Output Enable	–	–	–	–	L	–	Active	8
Write Inhibit/Output High-Z	–	–	–	–	H	–	High-Z	8

- NOTE:**
1. CKE is HIGH for all commands shown except SELF REFRESH.
 2. A0-A11 define the op-code written to the Mode Register.
 3. A0-A11 provide row address, and BA0, BA1 determine which bank is made active.
 4. A0-A7 provide column address; A10 HIGH enables the auto precharge feature (nonpersistent), while A10 LOW disables the auto precharge feature; BA0, BA1 determine which bank is being read from or written to.
 5. A10 LOW: BA0, BA1 determine which bank is being precharged. A10 HIGH: all banks are precharged and BA0, BA1 are "Don't Care."
 6. This command is AUTO REFRESH if CKE is HIGH, SELF REFRESH if CKE is LOW.
 7. Internal refresh counter controls row addressing; all inputs and I/Os are "Don't Care" except for CKE.
 8. Activates or deactivates the DQs during WRITES (zero-clock delay) and READs (two-clock delay).

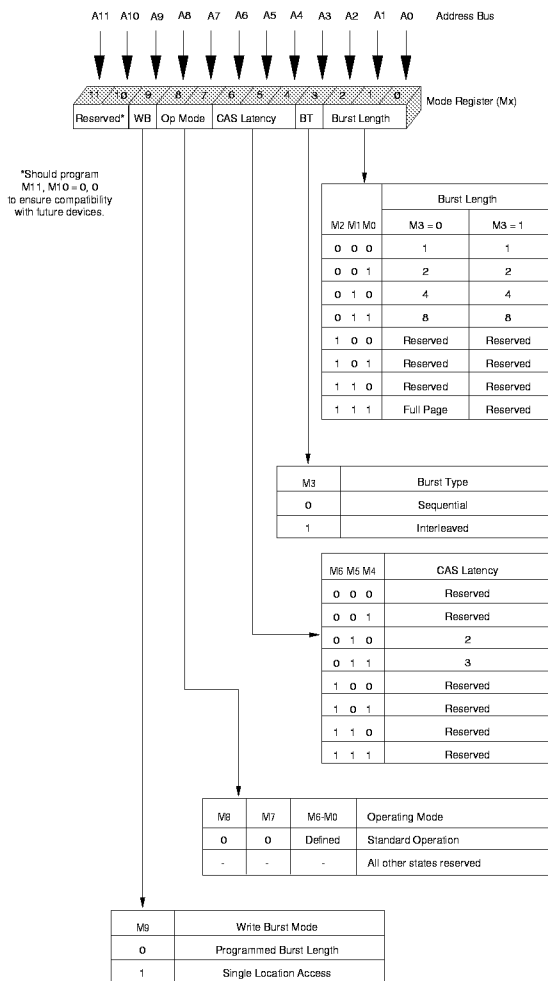

**Figure 1
MODE REGISTER DEFINITION**

**Table 1
BURST DEFINITION**

Burst Length	Starting Column Address:	Order of Accesses Within a Burst	
		Type = Sequential	Type = Interleaved
2	A0		
	0	0-1	0-1
	1	1-0	1-0
4	A1 A0		
	0 0	0-1-2-3	0-1-2-3
	0 1	1-2-3-0	1-0-3-2
	1 0	2-3-0-1	2-3-0-1
	1 1	3-0-1-2	3-2-1-0
8	A2 A1 A0		
	0 0 0	0-1-2-3-4-5-6-7	0-1-2-3-4-5-6-7
	0 0 1	1-2-3-4-5-6-7-0	1-0-3-2-5-4-7-6
	0 1 0	2-3-4-5-6-7-0-1	2-3-0-1-6-7-4-5
	0 1 1	3-4-5-6-7-0-1-2	3-2-1-0-7-6-5-4
	1 0 0	4-5-6-7-0-1-2-3	4-5-6-7-0-1-2-3
	1 0 1	5-6-7-0-1-2-3-4	5-4-7-6-1-0-3-2
1 1 0	6-7-0-1-2-3-4-5	6-7-4-5-2-3-0-1	
1 1 1	7-0-1-2-3-4-5-6	7-6-5-4-3-2-1-0	
Full Page (y)	n = A0-A7 (location 0-y)	Cn, Cn + 1, Cn + 2 Cn + 3, Cn + 4... ...Cn - 1, Cn...	Not supported

- NOTE:**
- For full-page accesses: y = 256.
 - For a burst length of two, A1-A7 select the block-of-two burst; A0 selects the starting column within the block.
 - For a burst length of four, A2-A7 select the block-of-four burst; A0-A1 select the starting column within the block.
 - For a burst length of eight, A3-A7 select the block-of-eight burst; A0-A2 select the starting column within the block.
 - For a full-page burst, the full row is selected, and A0-A7 select the starting column.
 - Whenever a boundary of the block is reached within a given sequence above, the following access wraps within the block.
 - For a burst length of one, A0-A7 select the unique column to be accessed, and Mode Register bit M3 is ignored.

ABSOLUTE MAXIMUM RATINGS*

Voltage on V_{DD} Supply Relative to V_{SS} -1V to +4.6V
 Voltage on Inputs, NC or I/O Pins
 Relative to V_{SS} -1V to +4.6V
 Operating Temperature, T_A (ambient) 0°C to +70°C
 Storage Temperature (plastic) -55°C to +125°C
 Power Dissipation 5W

*Stresses greater than those listed under “Absolute Maximum Ratings” may cause permanent damage to the device. This is a stress rating only, and functional operation of the device at these or any other conditions above those indicated in the operational sections of this specification is not implied. Exposure to absolute maximum rating conditions for extended periods may affect reliability.

DC ELECTRICAL CHARACTERISTICS AND OPERATING CONDITIONS

(Notes: 1, 6) (V_{DD} = +3.3V ±0.3V)

PARAMETER/CONDITION	SYMBOL	MIN	MAX	UNITS	NOTES
SUPPLY VOLTAGE	V _{DD}	3	3.6	V	
INPUT HIGH VOLTAGE: Logic 1; All inputs	V _{IH}	2	V _{DD} + 0.3	V	23
INPUT LOW VOLTAGE: Logic 0; All inputs	V _{IL}	-0.5	0.8	V	23
INPUT LEAKAGE CURRENT: Any input 0V ≤ V _{IN} ≤ V _{DD} (All other pins not under test = 0V)	DQMB0, DQMB2-DQMB7	I _{I1}	-5	5	μA
	CK2, S2#, DQMB1	I _{I2}	-10	10	μA
	CK0, S0#	I _{I3}	-15	15	μA
	CKE0, RAS#, CAS#, A0-A11, BA0-BA1, WE#	I _{I4}	-25	25	μA
OUTPUT LEAKAGE CURRENT: DQs are disabled; 0V ≤ V _{OUT} ≤ V _{DD}	I _{OZ}	-5	5	μA	
OUTPUT LEVELS: Output High Voltage (I _{OUT} = -4mA) Output Low Voltage (I _{OUT} = 4mA)	V _{OH}	2.4	-	V	
	V _{OL}	-	0.4	V	

I_{DD} SPECIFICATIONS AND CONDITIONS

(Notes: 1, 6, 11, 13) (V_{DD} = +3.3V ±0.3V)

PARAMETER/CONDITION	SYMBOL	MAX		UNITS	NOTES	
		-10B/-10C	-662			
OPERATING CURRENT: Active Mode; Burst = 2; READ or WRITE; t _{RC} = t _{RC} (MIN); CAS latency = 3; t _{CK} = 10ns (15ns for -662)	I _{DD1}	475	450	mA	3, 18, 19	
STANDBY CURRENT: Power-Down Mode; t _{CK} = 10ns (15ns for -662); CKE = LOW; All banks idle	I _{DD2}	10	15	mA		
STANDBY CURRENT: Active Mode; S0#, S2# = HIGH; t _{CK} = 10ns (15ns for -662); CKE = HIGH; All banks active after t _{RCD} met; No accesses in progress	I _{DD3}	175	150	mA	3, 12, 19	
OPERATING CURRENT: Burst Mode; Continuous burst; READ or WRITE; t _{CK} = 10ns (15ns for -662); All banks active; CAS latency = 3	I _{DD4}	650	525	mA	3, 18, 19	
AUTO REFRESH CURRENT: CKE = HIGH; S0#, S2# = HIGH; t _{CK} = 10ns (15ns for -662)	t _{RC} = t _{RC} (MIN); CL = 3	I _{DD5}	1,050	950	mA	3, 12, 18, 19
	t _{RC} = 15.625μs; CL = 3	I _{DD6}	175	150	mA	
SELF REFRESH CURRENT: CKE ≤ 0.2V	I _{DD7}	5	7.5	mA	4	

CAPACITANCE

PARAMETER	SYMBOL	MIN	MAX	UNITS	NOTES
Input Capacitance: A0-A11, BA0, BA1, RAS#, CAS#, WE#, CKE0	C _{I1}	15	26	pF	2
Input Capacitance: CK2, S2#, DQMB1	C _{I2}	6	10	pF	2
Input Capacitance: CK0, S0#	C _{I3}	9	15	pF	2
Input Capacitance: DQMB0#, DQMB2#-DQMB7#	C _{I4}	4	7	pF	2
Input Capacitance: SCL, SA0-SA2	C _{I5}	–	6	pF	2
Input/Output Capacitance: DQ0-DQ63, CB0-CB7, SDA	C _{I0}	6	9	pF	2

SDRAM COMPONENT* AC ELECTRICAL CHARACTERISTICS

(Notes: 5, 6, 8, 9, 11)

AC CHARACTERISTICS			-10C		-10B		-662			
PARAMETER		SYMBOL	MIN	MAX	MIN	MAX	MIN	MAX	UNITS	NOTES
Access time from CLK (pos. edge)	CL = 3	^t AC		6		6		7	ns	
	CL = 2	^t AC		9		9		9	ns	28
Address hold time		^t AH	1		1		1		ns	
Address setup time		^t AS	2		2		3		ns	
CLK high-level width		^t CH	3		3		3.5		ns	
CLK low-level width		^t CL	3		3		3.5		ns	
Clock cycle time	CL = 3	^t CK	8		8		10		ns	24
	CL = 2	^t CK	12		12		15		ns	24, 28
CKE hold time		^t CKH	1		1		1		ns	
CKE setup time		^t CKS	2		2		3		ns	
CS#, RAS#, CAS#, WE#, DQM hold time		^t CMH	1		1		1		ns	
CS#, RAS#, CAS#, WE#, DQM setup time		^t CMS	2		2		3		ns	
Data-in hold time		^t DH	1		1		1		ns	
Data-in setup time		^t DS	2		2		3		ns	
Data-out high-impedance time	CL = 3	^t HZ		6		6		8	ns	10
	CL = 2	^t HZ		7		7		10	ns	10
Data-out low-impedance time		^t LZ	1		1		2		ns	
Data-out hold time		^t OH	3		3		3		ns	
ACTIVE to PRECHARGE command		^t RAS	50	120,000	50	120,000	60	120,000	ns	
AUTO REFRESH, ACTIVE command period		^t RC	70		80		90		ns	28
ACTIVE to READ or WRITE delay		^t RCD	20		20		30		ns	28
Refresh period (4,096 cycles)		^t REF		64		64		64	ms	
PRECHARGE command period		^t RP	20		24		30		ns	28
ACTIVE bank A to ACTIVE bank B command		^t RRD	20		20		20		ns	
Transition time		^t T	0.3	1.2	0.3	1.2	1	1.2	ns	7
WRITE recovery time		^t WR	1 CLK + 8ns		1 CLK + 8ns		1 CLK + 8ns		–	25
			15		15		15		ns	26
Exit SELF REFRESH to ACTIVE command		^t XSR	80		80		90		ns	20

*Specifications for the SDRAM components used on the module.

AC FUNCTIONAL CHARACTERISTICS

(Notes: 5, 6, 7, 8, 9, 11)

PARAMETER	SYMBOL	-10C	-10B	-662	UNITS	NOTES	
READ/WRITE command to READ/WRITE command	^t CCD	1	1	1	^t CK	17	
CKE to clock disable or power-down entry mode	^t CKED	1	1	1	^t CK	14	
CKE to clock enable or power-down exit setup mode	^t PED	1	1	1	^t CK	14	
DQM to input data delay	^t DQD	0	0	0	^t CK	17	
DQM to data mask during WRITES	^t DQM	0	0	0	^t CK	17	
DQM to data high-impedance during READs	^t DQZ	2	2	2	^t CK	17	
WRITE command to input data delay	^t DWD	0	0	0	^t CK	17	
Data-in to ACTIVE command	^t DAL	4	5	4	^t CK	15, 21	
Data-in to PRECHARGE command	^t DPL	2	2	2	^t CK	16, 21	
Last data-in to burst STOP command	^t BDL	1	1	1	^t CK	17	
Last data-in to new READ/WRITE command	^t CDL	1	1	1	^t CK	17	
Last data-in to PRECHARGE command	^t RDL	2	2	2	^t CK	16, 21	
LOAD MODE REGISTER command to ACTIVE or REFRESH command	^t MRD	2	2	2	^t CK	27	
Data-out to high-impedance from PRECHARGE command	CL = 3	^t ROH	3	3	3	^t CK	17
	CL = 2	^t ROH	2	2	2	^t CK	17

SDRAM COMPONENT* ELECTRICAL TIMING CHARACTERISTICS BETWEEN -8 SPEED OPTIONS

(Notes: 5, 6, 8, 9, 11)

AC CHARACTERISTICS			-8E		-8D		-8C		-8B		-8A			
PARAMETER	SYM	MIN	MAX	MIN	MAX	MIN	MAX	MIN	MAX	MIN	MAX	UNITS	NOTES	
Access time from CLK (pos. edge)	CL = 3	^t AC	6	6	6	6	6	6	6	6	6	ns	28	
	CL = 2	^t AC	6	7	7	9	9	9	9	9	9	ns	28	
	CL = 1	^t AC	27	27	27	27	27	27	27	27	27	ns	28	
Clock cycle time	CL = 3	^t CK	8	8	8	8	8	8	8	8	8	ns	28	
	CL = 2	^t CK	10	10	12	12	12	12	12	12	12	ns	28	
	CL = 1	^t CK	30	30	30	30	30	30	30	30	30	ns	28	
ACTIVE to READ or WRITE delay	^t RCD	20	20	20	20	20	20	20	24	24	24	ns	28	
PRECHARGE command period	^t RP	20	20	20	20	24	24	24	24	24	24	ns	28	
AUTO REFRESH, ACTIVE command period	^t RC	70	70	70	70	80	80	80	80	80	80	ns	28	
WRITE recovery time	^t WR	2	2	2	2	2	2	2	2	2	2	^t CK	21	
100 MHz Speed Reference (CL- ^t RCD- ^t RP)			2-2-2	2-2-2	2-2-2	3-2-2	3-2-2	3-2-3	3-2-3	3-3-3	3-3-3	CLKs		

*Specifications for the SDRAM components used on the module.

SERIAL PRESENCE-DETECT EEPROM DC OPERATING CONDITIONS

(Notes: 1) ($V_{DD} = +3.3V \pm 0.3V$)

PARAMETER/CONDITION	SYMBOL	MIN	MAX	UNITS	NOTES
SUPPLY VOLTAGE	V_{DD}	3	3.6	V	
INPUT HIGH VOLTAGE: Logic 1; All inputs	V_{IH}	$V_{DD} \times 0.7$	$V_{DD} + 0.5$	V	
INPUT LOW VOLTAGE: Logic 0; All inputs	V_{IL}	-1	$V_{DD} \times 0.3$	V	
OUTPUT LOW VOLTAGE: $I_{OUT} = 3mA$	V_{OL}	-	0.4	V	
INPUT LEAKAGE CURRENT: $V_{IN} = GND$ to V_{DD}	I_{LI}	-	10	μA	
OUTPUT LEAKAGE CURRENT: $V_{OUT} = GND$ to V_{DD}	I_{LO}	-	10	μA	
STANDBY CURRENT: SCL = SDA = $V_{DD} - 0.3V$; All other inputs = GND or $3.3V + 10\%$	I_{SB}	-	30	μA	
POWER SUPPLY CURRENT: SCL clock frequency = 100 KHz	I_{DD}	-	2	mA	

SERIAL PRESENCE-DETECT EEPROM AC OPERATING CONDITIONS

(Notes: 1) ($V_{DD} = +3.3V \pm 0.3V$)

PARAMETER/CONDITION	SYMBOL	MIN	MAX	UNITS	NOTES
SCL LOW to SDA data-out valid	t_{AA}	0.3	3.5	μs	
Time the bus must be free before a new transition can start	t_{BUF}	4.7		μs	
Data-out hold time	t_{DH}	300		ns	
SDA and SCL fall time	t_F		300	ns	
Data-in hold time	$t_{HD:DAT}$	0		μs	
Start condition hold time	$t_{HD:STA}$	4		μs	
Clock HIGH period	t_{HIGH}	4		μs	
Noise suppression time constant at SCL, SDA inputs	t_I		100	ns	
Clock LOW period	t_{LOW}	4.7		μs	
SDA and SCL rise time	t_R		1	μs	
SCL clock frequency	t_{SCL}		100	KHz	
Data-in setup time	$t_{SU:DAT}$	250		ns	
Start condition setup time	$t_{SU:STA}$	4.7		μs	
Stop condition setup time	$t_{SU:STO}$	4.7		μs	
WRITE cycle time	t_{WRC}		10	ms	22

NOTES

1. All voltages referenced to V_{SS}.
2. This parameter is sampled. V_{DD} = +3.3V; f = 1 MHz.
3. I_{DD} is dependent on output loading and cycle rates. Specified values are obtained with minimum cycle time and the outputs open.
4. Enables on-chip refresh and address counters.
5. The minimum specifications are used only to indicate cycle time at which proper operation over the full temperature range (0°C ≤ T_A ≤ 70°C) is ensured.
6. An initial pause of 100μs is required after power-up, followed by two AUTO REFRESH commands, before proper device operation is ensured. The two AUTO REFRESH command wake-ups should be repeated any time the t_{REF} refresh requirement is exceeded.
7. AC characteristics assume t_T = 1 ns.
8. In addition to meeting the transition rate specification, the clock and CKE must transit between V_{IH} and V_{IL} (or between V_{IL} and V_{IH}) in a monotonic manner.
9. Outputs measured at 1.5V with equivalent load:

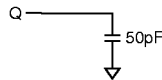

10. t_{HZ} defines the time at which the output achieves the open circuit condition; it is not a reference to V_{OH} or V_{OL}. The last valid data element will meet t_{OH} before going High-Z.
11. AC timing and I_{DD} tests have V_{IL} = 0V and V_{IH} = 3V, with timing referenced to 1.5V crossover point.
12. Other input signals are allowed to transition no more than once in any 30ns period (20ns on -10B/-10C) and are otherwise at valid V_{IH} or V_{IL} levels.
13. I_{DD} specifications are tested after the device is properly initialized.
14. Timing actually specified by t_{CKS}; clock(s) specified as a reference only at minimum cycle rate.
15. Timing actually specified by t_{WR} plus t_{RP}; clock(s) specified as a reference only at minimum cycle rate.

16. Timing actually specified by t_{WR}.
17. Required clocks are specified by JEDEC functionality and are not dependent on any timing parameter.
18. The I_{DD} current will decrease as the CAS latency is reduced. This is due to the fact that the maximum cycle rate is slower as the CAS latency is reduced.
19. Address transitions average one transition every 30ns (20ns on -10B/-10C).
20. CLK must be toggled a minimum of two times during this period.
21. Based on t_{CK} = 100 MHz for -10B/-10C and 66 MHz for -662.
22. The SPD EEPROM WRITE cycle time (t_{WRC}) is the time from a valid stop condition of a WRITE sequence to the end of the EEPROM internal erase/program cycle. During the WRITE cycle, the EEPROM bus interface circuit is disabled, SDA remains HIGH due to pull-up resistor, and the EEPROM does not respond to its slave address.
23. V_{IH} overshoot: V_{IH} (MAX) = V_{DD} + 2V for a pulse width ≤ 10ns, and the pulse width cannot be greater than one third of the cycle rate. V_{IL} undershoot: V_{IL} (MIN) = -2V for a pulse width ≤ 10ns, and the pulse width cannot be greater than one third of the cycle rate.
24. The clock frequency must remain constant during access or precharge states (READ, WRITE, including t_{WR}, and PRECHARGE commands). CKE may be used to reduce the data rate.
25. Auto precharge mode only. The precharge timing budget (t_{RP}) begins 8ns after the first clock delay, after the last WRITE is executed.
26. Precharge mode only.
27. JEDEC and PC100 specify three clocks.
28. These five parameters vary between speed grades and define the differences between the -8 SDRAM speeds: -8A, -8B, -8C, -8D and -8E. All other -8 timing parameters remain constant.

SPD EEPROM

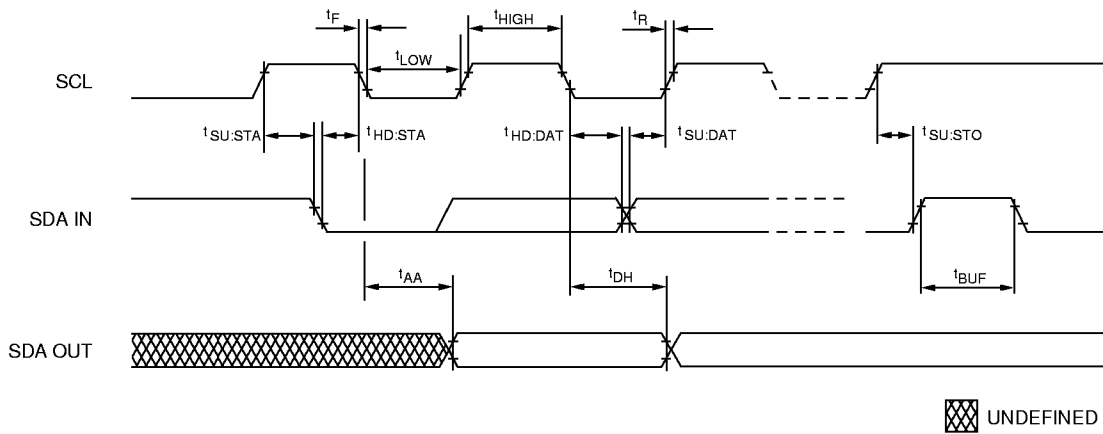

 UNDEFINED

**SERIAL PRESENCE-DETECT EEPROM
TIMING PARAMETERS**

SYMBOL	MIN	MAX	UNITS
t_{AA}	0.3	3.5	μ S
t_{BUF}	4.7		μ S
t_{DH}	300		ns
t_F		300	ns
$t_{HD:DAT}$	0		μ S
$t_{HD:STA}$	4		μ S

SYMBOL	MIN	MAX	UNITS
t_{HIGH}	4		μ S
t_{LOW}	4.7		μ S
t_R		1	μ S
$t_{SU:DAT}$	250		ns
$t_{SU:STA}$	4.7		μ S
$t_{SU:STO}$	4.7		μ S

168-PIN DIMM

FRONT VIEW

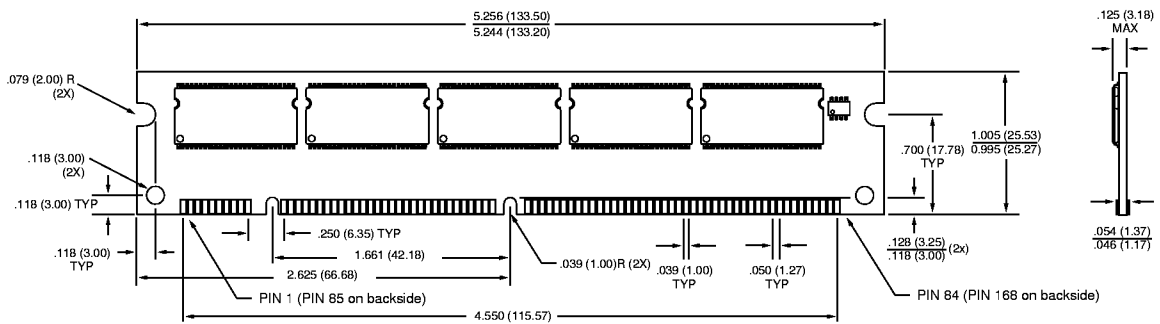

NOTE: 1. All dimensions in inches (millimeters) $\frac{\text{MAX}}{\text{MIN}}$ or typical where noted.