



DS0025C Two Phase MOS Clock Driver

General Description

The DS0025C is a monolithic, low cost, two phase MOS clock driver that is designed to be driven by TTL line drivers or buffers such as the DS8830 or DM7440. Two input coupling capacitors are used to perform the level shift from TTL to MOS logic levels. Optimum performance in turn-off delay and fall time are obtained when the output pulse is logically controlled by the input. However, output pulse width may be set by selection of the input capacitor eliminating the need for tight input pulse control.

Features

- 8-lead TO-5 or 8-lead or 14-lead dual-in-line package
- High Output Voltage Swings—up to 25V
- High Output Current Drive Capability—up to 1.5A
- Rep. Rate: 1.0 MHz into > 1000 pF
- Driven by DS8830, DM7440
- "Zero" Quiescent Power

Connection Diagrams

Metal Can Package

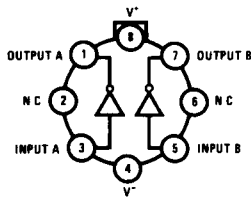

Note: Pin 4 connected to case.

Top View

Order Number DS0025CH
See NS Package Number H08C

TL/F/5852-1

Dual-In-Line Package

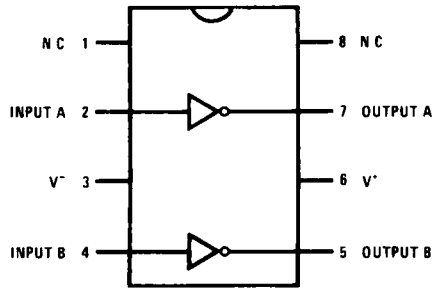

Top View

Order Number DS0025CJ-8
or DS0025CN
See NS Package Number J08A or N08E

TL/F/5852-2

Dual-In-Line Package

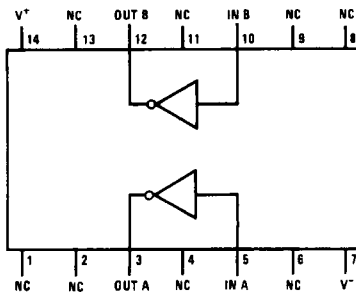

Top View

Order Number DS0025CJ
See NS Package Number J14A

TL/F/5852-3

Absolute Maximum Ratings (Note 1)

If Military/Aerospace specified devices are required, please contact the National Semiconductor Sales Office/Distributors for availability and specifications.

(V+ - V-) Voltage Differential	25V
Input Current	100 mA
Peak Output Current	1.5A
Storage Temperature	-65°C to +150°C
Operating Temperature	0°C to +85°C
Lead Temperature (Soldering, 10 sec)	300°C

Recommended Operating Conditions

V+ - V- Differential Voltage	20V
Temperature	0
Maximum Power Dissipation* at 25°C	Max
8-Pin Cavity Package	1150 mW
14-Pin Cavity Package	1410 mW
Molded Package	1080 mW
Metal Can (TO-5) Package	670 mW

* Derate 8-pin cavity package 7.8 mW/°C above 25°C; derate 14-pin cavity package 9.5 mW/°C above 25°C; derate molded package 8.7 mW/°C above 25°C; derate metal can (TO-5) package 4.5 mW/°C above 25°C.

Electrical Characteristics (Notes 2 and 3) See test circuit.

Symbol	Parameter	Conditions	Min	Typ	Max	Units	
t _{d ON}	Turn-On Delay Time	C _{IN} = 0.001 μF, R _{IN} = 0Ω, C _L = 0.001 μF		15	30	ns	
t _{RISE}	Rise Time	C _{IN} = 0.001 μF, R _{IN} = 0Ω, C _L = 0.001 μF		25	50	ns	
t _{d OFF}	Turn-Off Delay Time	C _{IN} = 0.001 μF, R _{IN} = 0Ω, C _L = 0.001 μF (Note 4)		30	60	ns	
t _{FALL}	Fall Time	C _{IN} = 0.001 μF, R _{IN} = 0Ω, C _L = 0.001 μF	(Note 4)	60	90	120	ns
			(Note 5)	100	150	250	ns
PW	Pulse Width (50% to 50%)	C _{IN} = 0.001 μF, R _{IN} = 0Ω, C _L = 0.001 μF (Note 5)		500		ns	
V _{O+}	Positive Output Voltage Swing	V _{IN} = 0V, I _{OUT} = -1 mA	V+ - 1.0	V+ - 0.7V		V	
V _{O-}	Negative Output Voltage Swing	I _{IN} = 10 mA, I _{OUT} = 1 mA		V- + 0.7V	V- + 1.5V	V	

Note 1: "Absolute Maximum Ratings" are those values beyond which the safety of the device cannot be guaranteed. Except for "Operating Temperature Range" they are not meant to imply that the devices should be operated at these limits. The table of "Electrical Characteristics" provides conditions for actual device operation.

Note 2: Unless otherwise specified min/max limits apply across the 0°C to 70°C range for the DS0025C.

Note 3: All currents into device pins shown as positive, out of device pins as negative, all voltages referenced to ground unless otherwise noted. All values shown as max or min on absolute value basis.

Note 4: Parameter values apply for clock pulse width determined by input pulse width.

Note 5: Parameter values for input width greater than output clock pulse width.

Timing Diagram

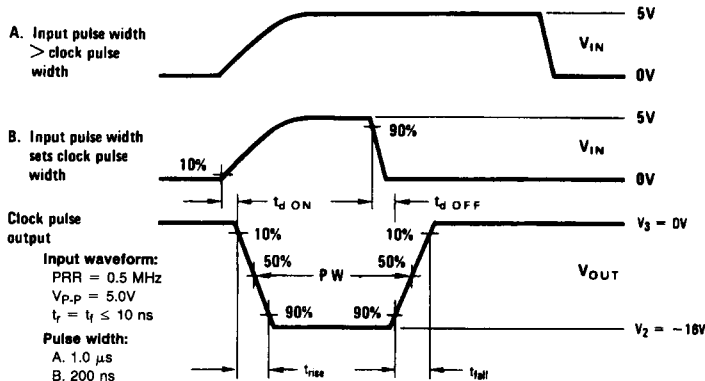

TL/F/5852-5

Typical Application

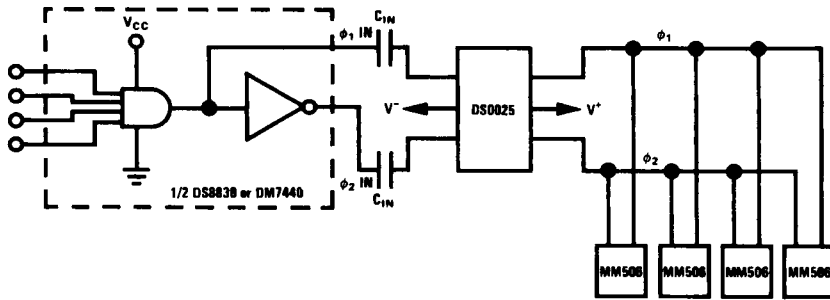

TL/F/5852-4

AC Test Circuit

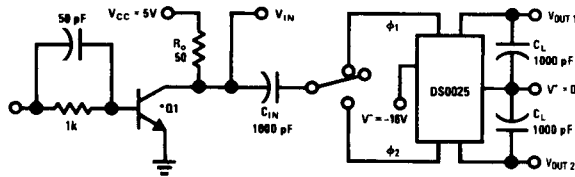

TL/F/5852-6

*Q1 is selected high speed NPN switching transistor.

Typical Performance

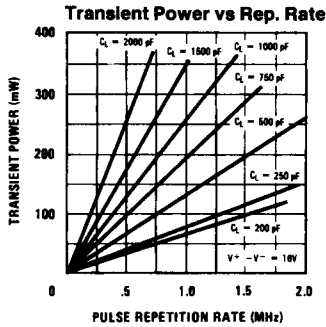

TL/F/5852-7

$$P_{AC} = (V^+ - V^-)^2 (IC_L)$$

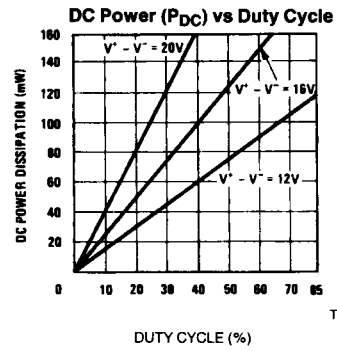

TL/F/5852-8

$$P_{DC} = \frac{(V^+ - V^-)^2 (DC)}{1k}$$

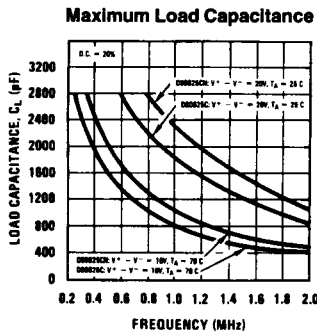

TL/F/5852-9

$$C_L < \frac{(P_{MAX})(1k) - (V^+ - V^-)^2 (DC)}{(f)(1k)(V^+ - V^-)^2} < \frac{(t_{pk})(t_r)}{V^+ - V^-}$$

Output PW Controlled by C1IN

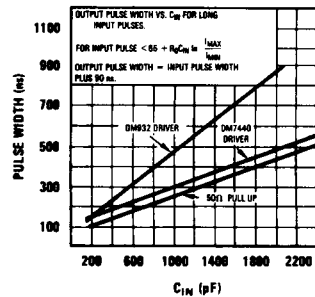

TL/F/5852-10

IMAX = Peak Current delivered by driver

$$I_{MIN} = \frac{V_{BE}}{R_I} = \frac{0.6}{1k}$$

Applications Information

Circuit Operation

Input current forced into the base of Q_1 through the coupling capacitor C_{IN} causes Q_1 to be driven into saturation, swinging the output to $V^- + V_{CE(sat)} + V_{Diode}$.

When the input current has decayed, or has been switched, such that Q_1 turns off, Q_2 receives base drive through R_2 , turning Q_2 on. This supplies current to the load and the output swings positive to $V^+ - V_{BE}$.

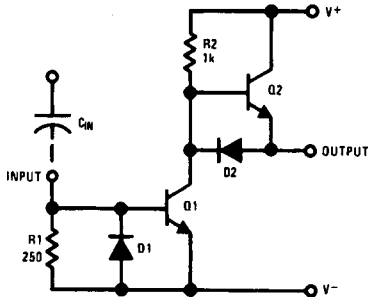

TL/F/5852-11

FIGURE 1. DS0025 Schematic (One-Half Circuit)

It may be noted that Q_1 must switch off before Q_2 begins to supply current, hence high internal transient currents from V^- to V^+ cannot occur.

Fan-Out Calculation

The drive capability of the DS0025 is a function of system requirements, i.e. speed, ambient temperature, voltage swing, drive circuitry, and stray wiring capacity.

The following equations cover the necessary calculations to enable the fan-out to be calculated for any system condition.

Transient Current

The maximum peak output current of the DS0025 is given as 1.5A. Average transient current required from the driver can be calculated from:

$$I = \frac{C_L (V^+ - V^-)}{t_r} \quad (1)$$

Typical rise times into 1000 pF load is 25 ns. For $V^+ - V^- = 20V$, $I = 0.8A$.

Transient Output Power

The average transient power (P_{AC}) dissipated, is equal to the energy needed to charge and discharge the output capacitive load (C_L) multiplied by the frequency of operation (f).

$$P_{AC} = C_L \times (V^+ - V^-)^2 \times f \quad (2)$$

For $V^+ - V^- = 20V$, $f = 1.0$ MHz, $C_L = 1000$ pF, $P_{AC} = 400$ mW.

Internal Power

"0" State Negligible (<3 mW)

"1" State

$$P_{int} = \frac{(V^+ - V^-)^2}{R_2} \times \text{Duty Cycle} \quad (3)$$

$$= 80 \text{ mW for } V^+ - V^- = 20V, \text{ DC} = 20\%$$

Package Power Dissipation

Total average power = transient output power + internal power.

Example Calculation

How many MM506 shift registers can be driven by a DS0025CN driver at 1 MHz using a clock pulse width of 200 ns, rise time 30-50 ns and 16V amplitude over the temperature range 0°-70°C?

Power Dissipation:

At 70°C the DS0025CN can dissipate 870 mW when soldered into printed circuit board.

Transient Peak Current Limitation:

From equation (1), it can be seen that at 16V and 30 ns, the maximum load that can be driven is limited to 2800 pF.

Average Internal Power:

Equation (3), gives an average power of 50 mW at 16V and a 20% duty cycle.

For one-half of the DS0025C, 870 mW ÷ 2 can be dissipated.

435 mW = 50 mW + transient output power.

385 mW = transient output power.

Using equation (2) at 16V, 1 MHz and 350 mW, each half of the DS0025CN can drive a 1367 pF load. This is less than the load imposed by the transient current limitation of equation (1) and so a maximum load of 1367 pF would prevail.

From the data sheet for the MM506, the average clock pulse load is 80 pF. Therefore the number of devices driven is 1367/80 or 17 registers.

For further information please refer to National Semiconductors Application Note AN-76.