

UT54ACS164245S/SE

RadHard Schmitt CMOS 16-bit Bidirectional MultiPurpose Transceiver Datasheet



December 2004
www.aeroflex.com/radhard

FEATURES

- Voltage translation
 - 5V bus to 3.3V bus
 - 3.3V bus to 5V bus
- Cold sparing
 - 1MΩ minimum input impedance power-off
- 0.6μm Commercial RadHard™ CMOS
 - Total dose: 100K rad(Si)
 - Single Event Latchup immune
- High speed, low power consumption
- Schmitt trigger inputs to filter noisy signals
- Available QML Q or V processes
- Standard Microcircuit Drawing 5962-98580
- Package:
 - 48-lead flatpack, 25 mil pitch (.390 x .640)

DESCRIPTION

The 16-bit wide UT54ACS164245S MultiPurpose transceiver is built using UTMC's Commercial RadHard™ epitaxial CMOS technology and is ideal for space applications. This high speed, low power UT54ACS164245S transceiver is designed to perform multiple functions including: asynchronous two-way communication, signal buffering, voltage translation, and cold sparing. With V_{DD} equal to zero volts, the UT54ACS164245S outputs and inputs present a minimum impedance of 1MΩ making it ideal for "cold spare" applications. Balanced outputs and low "on" output impedance make the UT54ACS164245S well suited for driving high capacitance loads and low impedance backplanes. The UT54ACS164245S enables system designers to interface 3.3 volt CMOS compatible components with 5 volt CMOS components. For voltage translation, the A port interfaces with the 3.3 volt bus; the B port interfaces with the 5 volt bus. The direction control (\overline{DIRx}) controls the direction of data flow. The output enable (\overline{OEx}) overrides the direction control and disables both ports. These signals can be driven from either port A or B. The direction and output enable controls operate these devices as either two independent 8-bit transceivers or one 16-bit transceiver.

LOGIC SYMBOL

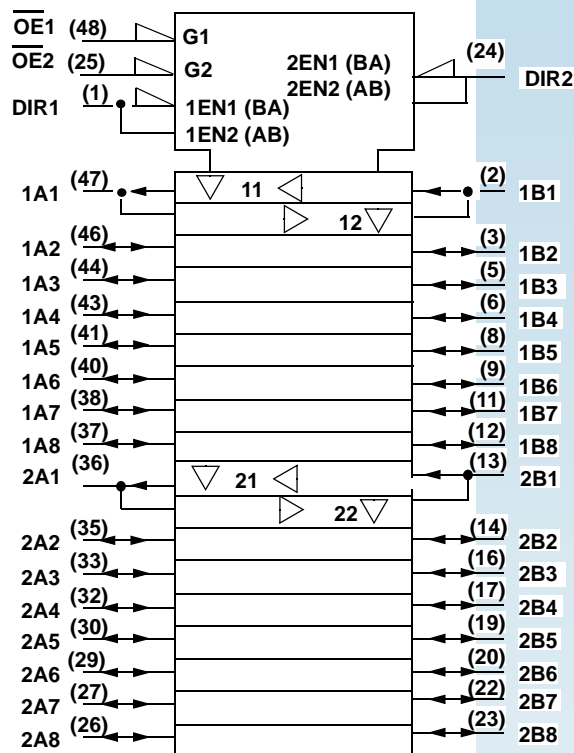

PIN DESCRIPTION

Pin Names	Description
\overline{OEx}	Output Enable Input (Active Low)
\overline{DIRx}	Direction Control Inputs
xAx	Side A Inputs or 3-State Outputs (3.3V Port)
xBx	Side B Inputs or 3-State Outputs (5V Port)

FUNCTION TABLE

ENABLE \overline{OEx}	DIRECTION \overline{DIRx}	OPERATION
L	L	B Data To A Bus
L	H	A Data To B Bus
H	X	Isolation

PINOUTS

**48-Lead Flatpack
Top View**

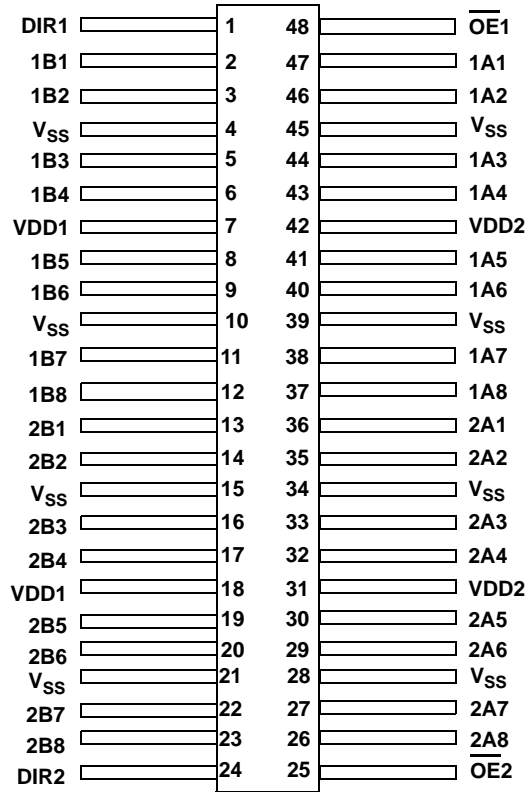

POWER TABLE¹

Port B	Port A	OPERATION
5 Volts	3.3 Volts	Voltage Translator
5 Volts	5 Volts	Non Translating
3.3 Volts	3.3 Volts	Non Translating
V _{SS}	V _{SS}	Cold Spare
V _{SS}	3.3V or 5V	Port B Cold Spare

NOTE:

1. V_{DD2} cannot be tied to V_{SS} while power is applied to V_{DD1}.

Control signals DIRx and \overline{OEx} are 5 volt tolerant inputs. When V_{DD2} is at 3.3 volts, either 3.3 or 5 volt CMOS logic levels can be applied to all control inputs. For proper operation connect power to all V_{DD} and ground all V_{SS} pins (i.e., no floating V_{DD} or V_{SS} input pins). Tie unused inputs to V_{SS}. If V_{DD1} and V_{DD2} are not powered up together, then V_{DD2} should be powered up first for proper control of \overline{OE} and DIR. Until V_{DD2} reaches 2.75V ± 5%, control of the outputs by \overline{OE} and DIR cannot be guaranteed. During operation of the part, after power up, insure V_{DD1} ≥ V_{DD2}. Tie unused inputs to V_{SS}.

LOGIC DIAGRAM

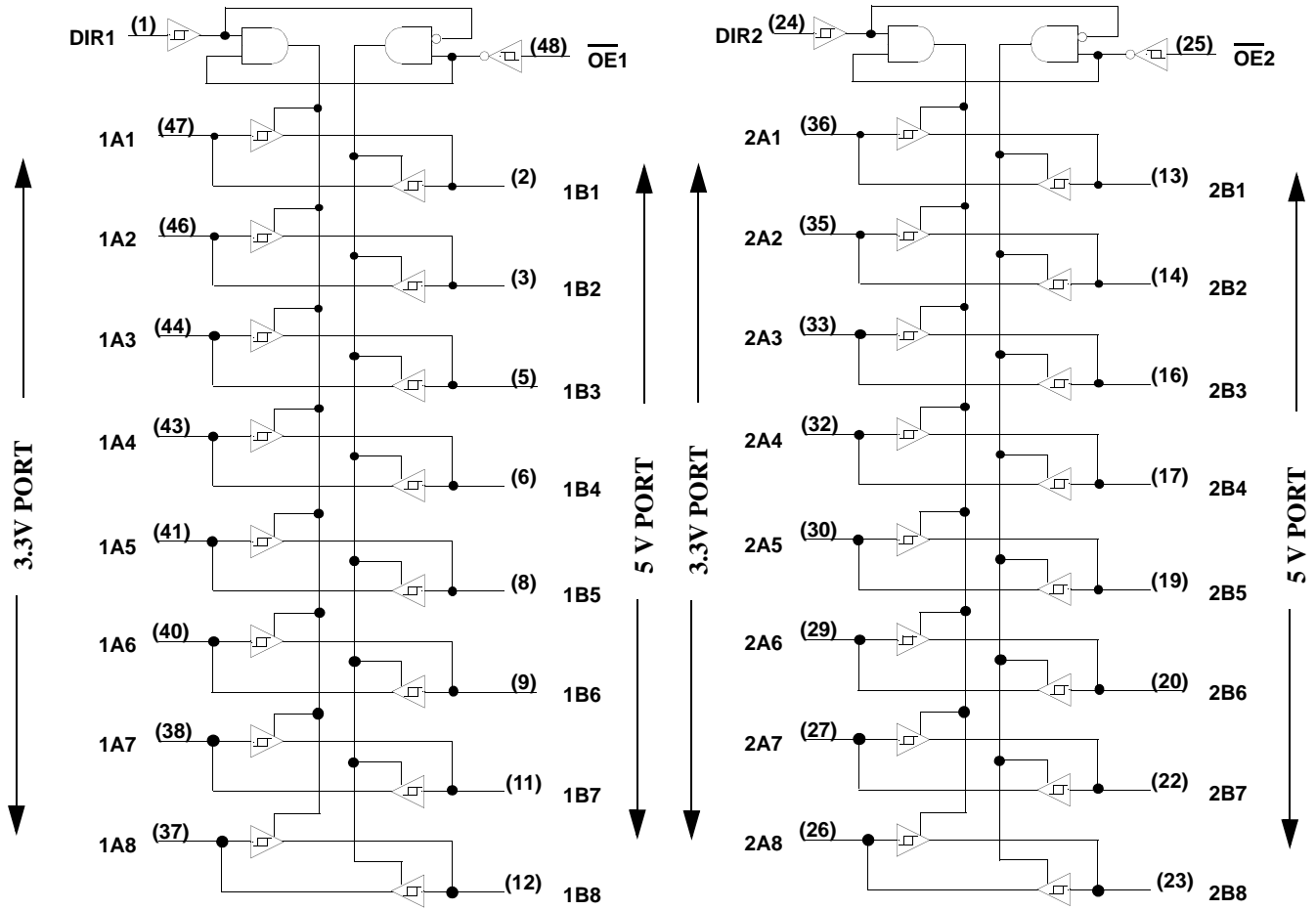

RADIATION HARDNESS SPECIFICATIONS ¹

PARAMETER	LIMIT	UNITS
Total Dose	1.0E5	rad(Si)
SEL Latchup	>120	MeV-cm ² /mg
Neutron Fluence ²	1.0E14	n/cm ²

Notes:

1. Logic will not latchup during radiation exposure within the limits defined in the table.
2. Not tested, inherent of CMOS technology.

ABSOLUTE MAXIMUM RATINGS¹

SYMBOL	PARAMETER	LIMIT (Mil only)	UNITS
V _{I/O} (Port B) ²	Voltage any pin during operation	-.3 to V _{DD1} +.3	V
V _{I/O} (Port A) ²	Voltage any pin during operation	-.3 to V _{DD2} +.3	
V _{DD1}	Supply voltage	-0.3 to 6.0	V
V _{DD2}	Supply voltage	-0.3 to 6.0	V
T _{STG}	Storage Temperature range	-65 to +150	°C
T _J	Maximum junction temperature	+175	°C
Θ _{JC}	Thermal resistance junction to case	20	°C/W
I _I	DC input current	±10	mA
P _D	Maximum power dissipation	1	W

Note:

1. Stresses outside the listed absolute maximum ratings may cause permanent damage to the device. This is a stress rating only, functional operation of the device at these or any other conditions beyond limits indicated in the operational sections is not recommended. Exposure to absolute maximum rating conditions for extended periods may affect device reliability and performance.
2. For cold spare mode (V_{DD} = V_{SS}), V_{I/O} may be -0.3V to the maximum recommended operating V_{DD} + 0.3V.

DUAL SUPPLY OPERATING CONDITIONS

SYMBOL	PARAMETER	LIMIT	UNITS
V _{DD1}	Supply voltage	3.0 to 3.6 or 4.5 to 5.5	V
V _{DD2}	Supply voltage	3.0 to 3.6 or 4.5 to 5.5	V
V _{IN} (Port B)	Input voltage any pin	0 to V _{DD1}	V
V _{IN} (Port A)	Input voltage any pin	0 to V _{DD2}	V
T _C	Temperature range	-55 to + 125	°C

DC ELECTRICAL CHARACTERISTICS¹(-55°C < T_C < +125°C) (T_C = -55°C to +125°C for "C" screening and -40°C to +125°C for "W" screening)

SYMBOL	PARAMETER	CONDITION	MIN	MAX	UNIT
V _{T+}	Schmitt Trigger, positive going threshold ²	V _{DD} from 3.00 to 5.5		.7V _{DD}	V
V _{T-}	Schmitt Trigger, negative going threshold ²	V _{DD} from 3.00 to 5.5	.3V _{DD}		V
V _{H1}	Schmitt Trigger range of hysteresis ¹⁰	V _{DD} from 4.5 to 5.5	0.6		V
V _{H2}	Schmitt Trigger range of hysteresis ¹⁰	V _{DD} from 3.00 to 3.6	0.4		V
I _{IN}	Input leakage current ¹⁰	V _{DD} from 3.6 to 5.5 V _{IN} = V _{DD} or V _{SS}	-1	3	μA
I _{OZ}	Three-state output leakage current ¹⁰	V _{DD} from 3.6 to 5.5 V _{IN} = V _{DD} or V _{SS}	-1	3	μA
I _{CS}	Cold sparing leakage current ³	V _{IN} = 5.5 V _{DD} = V _{SS}	-1	5	μA
I _{OS1}	Short-circuit output current ^{6, 11}	V _O = V _{DD} or V _{SS} V _{DD} from 4.5 to 5.5	-200	200	mA
I _{OS2}	Short-circuit output current ^{6, 11}	V _O = V _{DD} or V _{SS} V _{DD} from 3.00 to 3.6	-100	100	mA
V _{OL1}	Low-level output voltage ^{4, 10}	I _{OL} = 8mA I _{OL} = 100μA V _{DD} = 4.5		0.4 0.2	V
V _{OL2}	Low-level output voltage ^{4, 10}	I _{OL} = 8mA I _{OL} = 100μA V _{DD} = 3.00		0.5 0.2	V
V _{OH1}	High-level output voltage ^{4, 10}	I _{OH} = -8mA I _{OH} = -100μA V _{DD} = 4.5	V _{DD} - 0.7 V _{DD} - 0.2		V
V _{OH2}	High-level output voltage ^{4, 10}	I _{OH} = -8mA I _{OH} = -100μA V _{DD} = 3.00	V _{DD} - 0.9 V _{DD} - 0.2		V

P_{total1}	Power dissipation ^{5,7,8}	$C_L = 50\text{pF}$ V_{DD} from 4.5 to 5.5		2.0	mW/ MHz
P_{total2}	Power dissipation ^{5,7,8}	$C_L = 50\text{pF}$ V_{DD} from 3.00 to 3.6		1.5	mW/ MHz
I_{DD}	Standby Supply Current V_{DD1} or V_{DD2} Pre-Rad 25°C Pre-Rad -55°C to +125°C Post-Rad 25°C	$V_{IN} = V_{DD}$ or V_{SS} $V_{DD} = 5.5$ $\overline{OE} = V_{DD}$ $\overline{OE} = V_{DD}$ $\overline{OE} = V_{DD}$		10 100 500	μA μA μA
C_{IN}	Input capacitance ⁹	$f = 1\text{MHz @ } 0\text{V}$ V_{DD} from 3.00 to 5.5		15	pF
C_{OUT}	Output capacitance ⁹	$f = 1\text{MHz @ } 0\text{V}$ V_{DD} from 3.00 to 5.5		15	pF

Notes:

1. All specifications valid for radiation dose $\leq 1\text{E}5$ rad(Si) per MIL-STD-883, Method 1019.
2. Functional tests are conducted in accordance with MIL-STD-883 with the following input test conditions: $V_{IH} = V_{IH}(\text{min}) + 20\%$, $- 0\%$; $V_{IL} = V_{IL}(\text{max}) + 0\%$, $- 50\%$, as specified herein, for TTL, CMOS, or Schmitt compatible inputs. Devices may be tested using any input voltage within the above specified range, but are guaranteed to $V_{IH}(\text{min})$ and $V_{IL}(\text{max})$.
3. All combinations of $\overline{OE}x$ and $\text{DIR}x$
4. Per MIL-PRF-38535, for current density $\leq 5.0\text{E}5$ amps/cm², the maximum product of load capacitance (per output buffer) times frequency should not exceed 3,765 pF-MHz.
5. Guaranteed by characterization.
6. Not more than one output may be shorted at a time for maximum duration of one second.
7. Power does not include power contribution of any CMOS output sink current.
8. Power dissipation specified per switching output.
9. Capacitance measured for initial qualification and when design changes may affect the value. Capacitance is measured between the designated terminal and V_{SS} at frequency of 1MHz and a signal amplitude of 50mV rms maximum.
10. Guaranteed; tested on a sample of pins per device.
11. Supplied as a design limit, but not guaranteed or tested.

AC ELECTRICAL CHARACTERISTICS¹ (Port B = 5 Volt, Port A = 3.3 Volt)

(V_{DD1} = 5V ±10%; V_{DD2} = 3.00V to 3.6V, -55°C < T_C < +125°C) (T_C = -55°C to +125°C for "C" screening and -40°C to +125°C for "W" screening)

SYMBOL	PARAMETER	MIN	MAX	MIN	MAX	UNIT
		UT54ACS164245S		UT54ACS164245SE		
t _{PLH}	Propagation delay Data to Bus	1	20	3.5	11	ns
t _{PHL}	Propagation delay Data to Bus	1	20	3.5	11	ns
t _{PZL}	Output enable time $\overline{OE}x$ to Bus	1	18	2.5	16	ns
t _{PZH}	Output enable time $\overline{OE}x$ to Bus	1	18	2.5	16	ns
t _{PLZ}	Output disable time $\overline{OE}x$ to Bus high impedance	1	20	2.5	16	ns
t _{PHZ}	Output disable time $\overline{OE}x$ to Bus high impedance	1	20	2.5	16	ns
t _{PZL} ²	Output enable time DIRx to Bus	1	18	1	18	ns
t _{PZH} ²	Output enable time DIRx to Bus	1	18	1	18	ns
t _{PLZ} ²	Output disable time DIRx to Bus high impedance	1	20	1	20	ns
t _{PHZ} ²	Output disable time DIRx to Bus high impedance	1	20	1	20	ns
t _{SKEW} ³	Skew between outputs			-	600	ps
t _{DSKEW} ⁴	Differential skew between outputs			-	1.5	ns

Notes:

1. All specifications valid for radiation dose ≤ 1E5 rad(Si) per MIL-STD-883, Method 1019.
2. DIRx to bus times are guaranteed by design, but not tested. $\overline{OE}x$ to bus times are tested
3. Output skew is defined as a comparison of any two output transitions high-to-low vs. high-to-low and low-to-high vs low-to-high.
4. Differential skew is defined as a comparison of any two output transitions high-to-low vs. low-to-high and low-to-high vs high-to low.

Propagation Delay

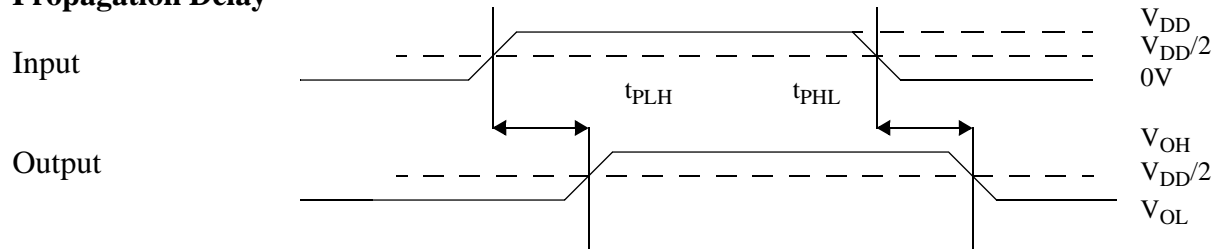

Enable Disable Times

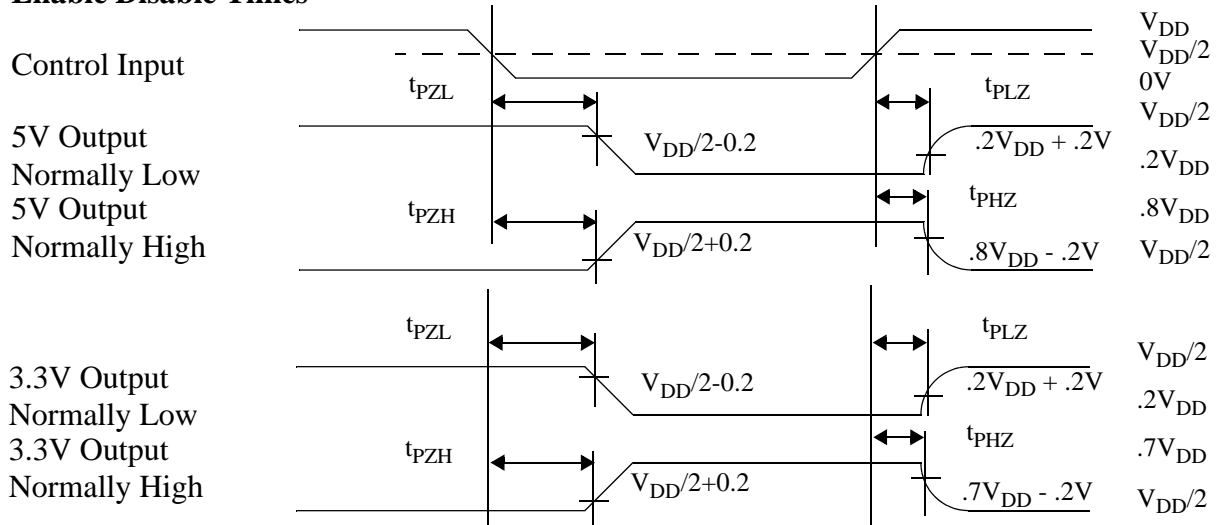

AC ELECTRICAL CHARACTERISTICS¹ (Port A = Port B, 5 Volt Operation)

(V_{DD1} = 5V ±10%; V_{DD2} = 5.0V ±10%, -55°C < T_C < +125°C)

SYMBOL	PARAMETER	MIN	MAX	MIN	MAX	UNIT
		UT54ACS164245S		UT54ACS164245SE		
t _{PLH}	Propagation delay Data to Bus	1	15	3.5	9	ns
t _{PHL}	Propagation delay Data to Bus	1	15	3.5	9	ns
t _{PZL}	Output enable time $\overline{OE}x$ to Bus	1	12	3	9	ns
t _{PZH}	Output enable time $\overline{OE}x$ to Bus	1	12	3	9	ns
t _{PLZ}	Output disable time $\overline{OE}x$ to Bus high impedance	1	15	3	9	ns
t _{PHZ}	Output disable time $\overline{OE}x$ to Bus high impedance	1	15	3	9	ns
t _{PZL} ²	Output enable time DIRx to Bus	1	12	1	12	ns
t _{PZH} ²	Output enable time DIRx to Bus	1	12	1	12	ns
t _{PLZ} ²	Output disable time DIRx to Bus high impedance	1	15	1	15	ns
t _{PHZ} ²	Output disable time DIRx to Bus high impedance	1	15	1	15	ns
t _{SKEW} ³	Skew between outputs			-	600	ps
t _{DSKEW} ⁴	Differential skew between outputs			-	1.5	ns

Notes:

1. All specifications valid for radiation dose ≤ 1E5 rad(Si) per MIL-STD-883, Method 1019.
2. DIRx to bus times are guaranteed by design, but not tested. $\overline{OE}x$ to bus times are tested
3. Output skew is defined as a comparison of any two output transitions high-to-low vs. high-to-low and low-to-high vs low-to-high.
4. Differential skew is defined as a comparison of any two output transitions high-to-low vs. low-to-high and low-to-high vs high-to low.

Propagation Delay

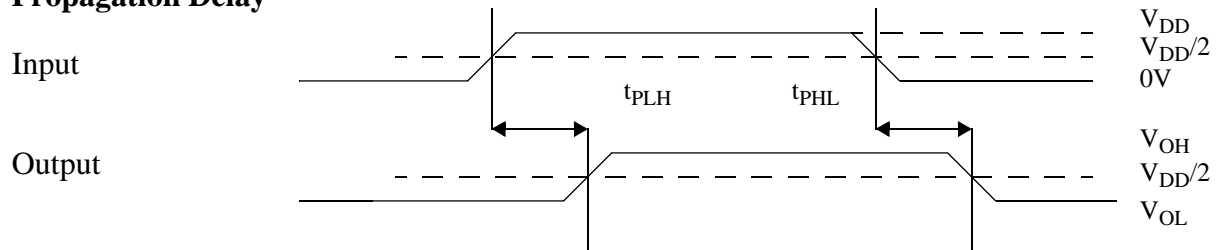

Enable Disable Times

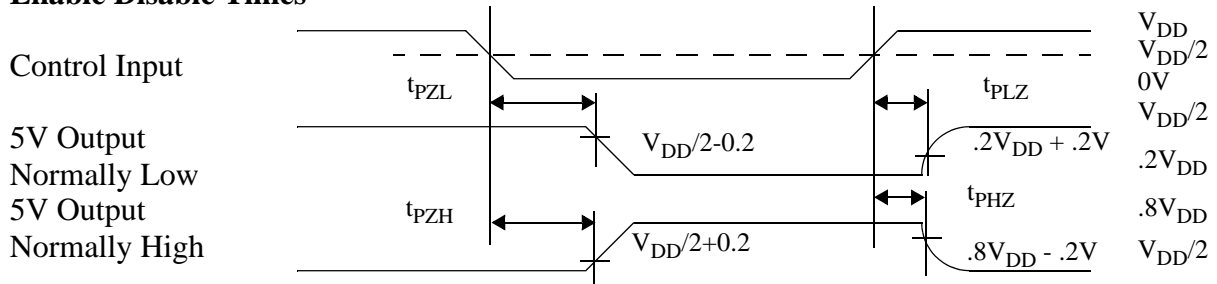

Propagation Delay

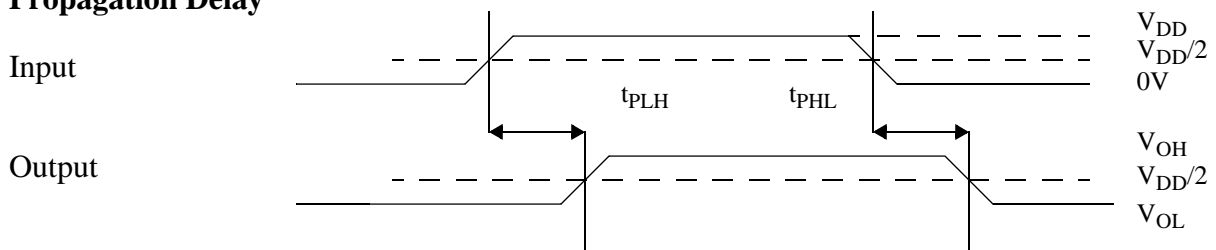

Enable Disable Times

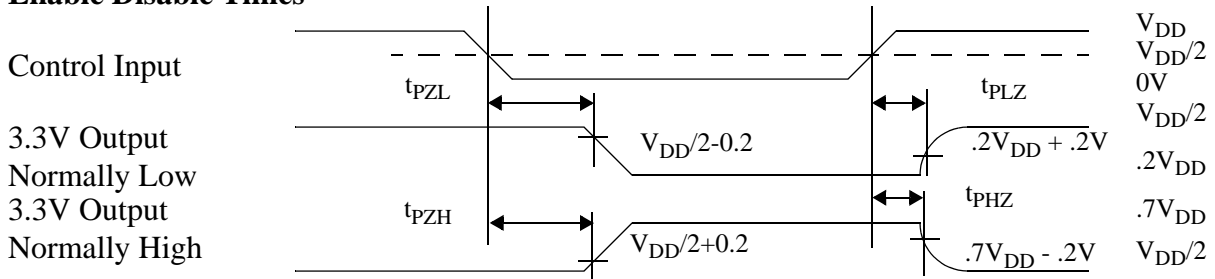

AC ELECTRICAL CHARACTERISTICS¹ (Port A = Port B, 3.3 Volt Operation)

(V_{DD1} = 3.00V to 3.6V; V_{DD2} = 3.00V to 3.6V, -55°C < T_C < +125°C)

SYMBOL	PARAMETER	MIN	MAX	MIN	MAX	UNIT
		UT54ACS164245S		UT54ACS164245SE		
t _{PLH}	Propagation delay Data to Bus	1	20	3.5	11	ns
t _{PHL}	Propagation delay Data to Bus	1	20	3.5	11	ns
t _{PZL}	Output enable time $\overline{\text{OEx}}$ to Bus	1	18	2.5	16	ns
t _{PZH}	Output enable time $\overline{\text{OEx}}$ to Bus	1	18	2.5	16	ns
t _{PLZ}	Output disable time $\overline{\text{OEx}}$ to Bus high impedance	1	20	2.5	16	ns
t _{PHZ}	Output disable time $\overline{\text{OEx}}$ to Bus high impedance	1	20	2.5	16	ns
t _{PZL} ²	Output enable time DIRx to Bus	1	18	1	18	ns
t _{PZH} ²	Output enable time DIRx to Bus	1	18	1	18	ns
t _{PLZ} ²	Output disable time DIRx to Bus high impedance	1	20	1	20	ns
t _{PHZ} ²	Output disable time DIRx to Bus high impedance	1	20	1	20	ns
t _{SKEW} ³	Skew between outputs				600	ps
t _{DSKEW} ⁴	Differential skew between outputs				1.5	ns

Notes:

1. All specifications valid for radiation dose ≤ 1E5 rad(Si) per MIL-STD-883, Method 1019.
2. DIRx to bus times are guaranteed by design, but not tested. OEx to bus times are tested.
3. Output skew is defined as a comparison of any two output transitions high-to-low vs. high-to-low and low-to-high vs low-to-high.
4. Differential skew is defined as a comparison of any two output transitions high-to-low vs. low-to-high and low-to-high vs high-to low.

PACKAGE

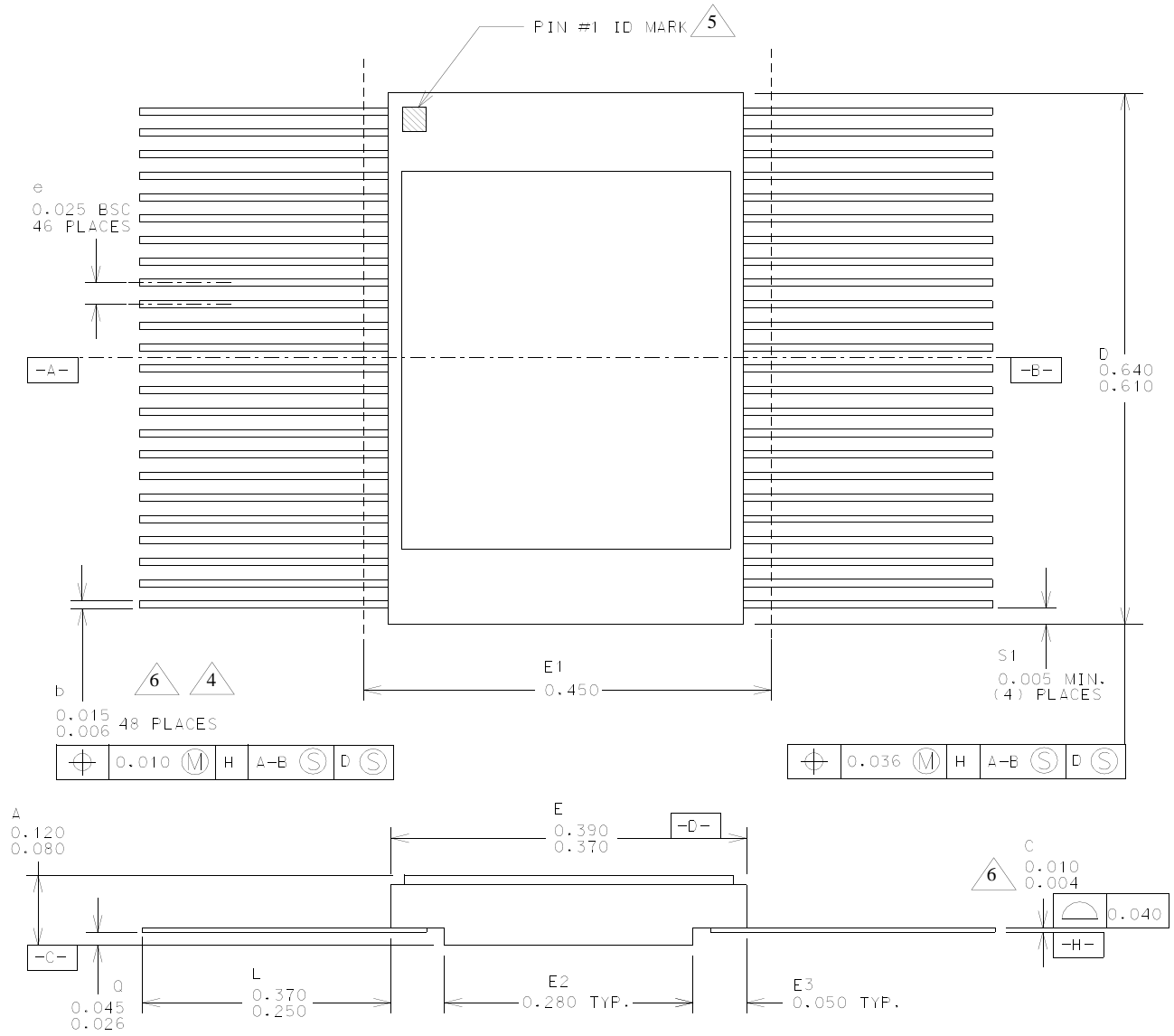

1. All exposed metalized areas are gold plated over electroplated nickel per MIL-PRF-38535.
2. The lid is electrically connected to VSS.
3. Lead finishes are in accordance with MIL-PRF-38535.
4. Lead position and colanarity are not measured.
5. ID mark symbol is vendor option.
6. With solder, increase maximum by 0.003.

Figure 1. 48-Lead Flatpack

ORDERING INFORMATION

UT54ACS164245S: SMD

5962 R 98580 ** * * *

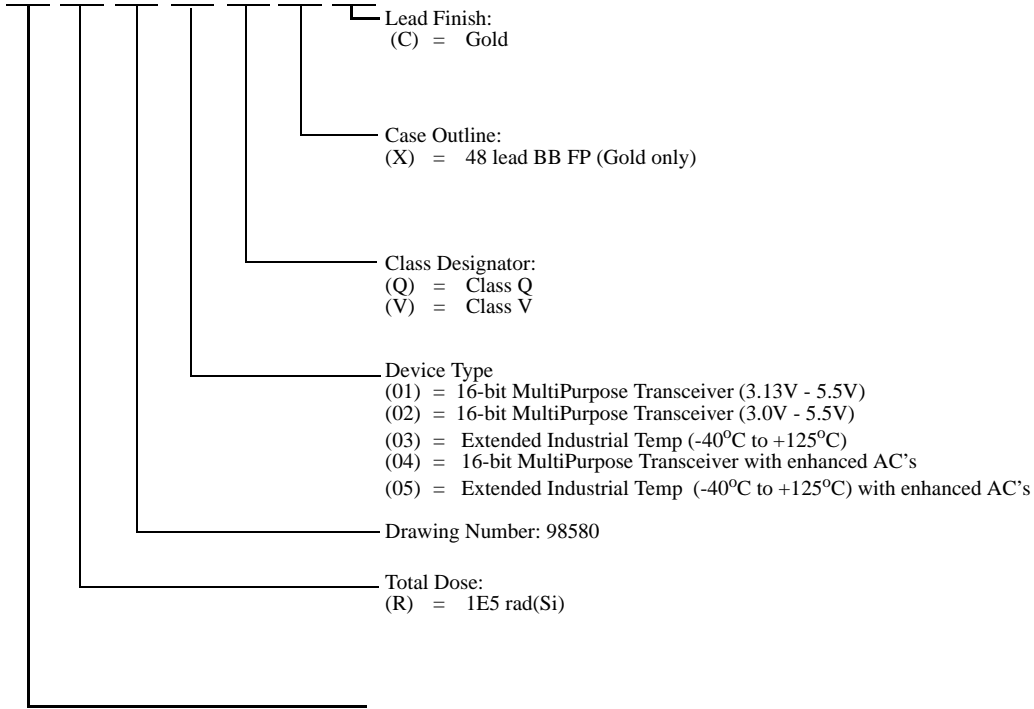

Federal Stock Class Designator: No options

Notes:

1. Total dose radiation must be specified when ordering. QML Q and QML V not available without radiation hardening.

Notes:

1. Military Temperature Range flow per UTMC Manufacturing Flows Document. Devices are tested -55C, room temp, and 125C. Radiation neither tested nor guaranteed.
2. Prototype flow per UTMC Manufacturing Flows Document Tested at 25C only. Lead finish is gold only.
3. **Extended Industrial Temperature Range Flow per UTMC Manufacturing Flows Document. Devices are tested at -40°C, room temp, and +125°C. Radiation is neither tested nor guaranteed**

UT54ACS164245S

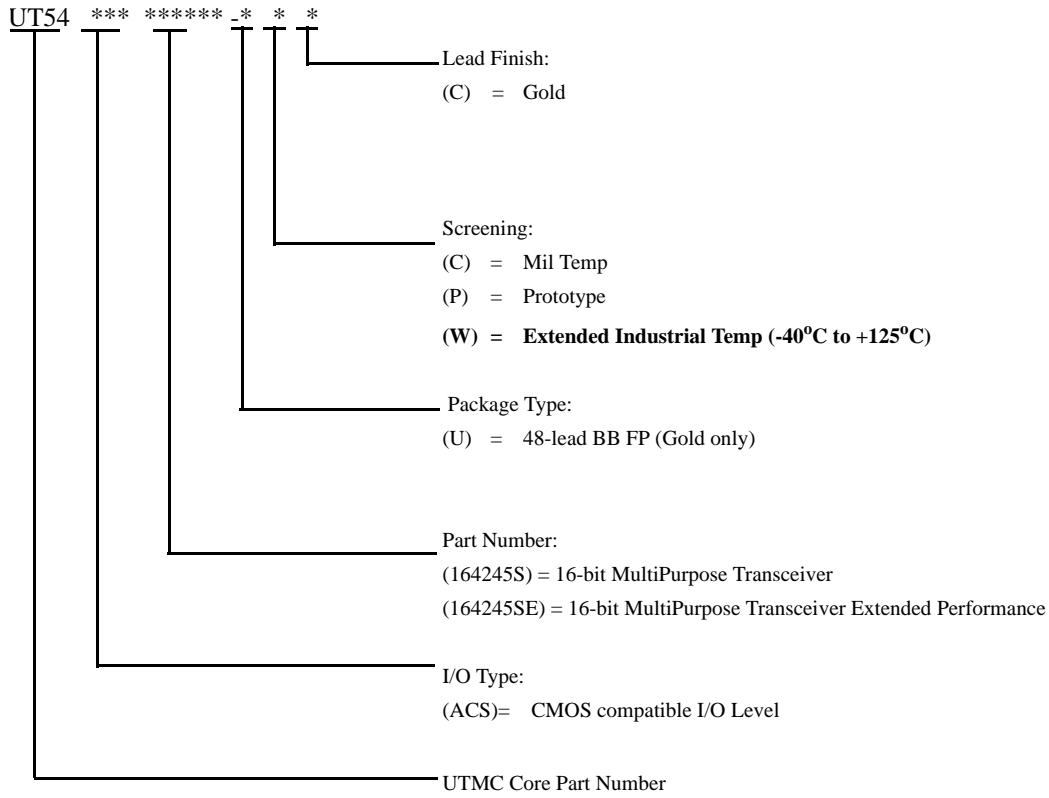

COLORADO

Toll Free: 800-645-8862
Fax: 719-594-8468

INTERNATIONAL

Tel: 805-778-9229
Fax: 805-778-1980

NORTHEAST

Tel: 603-888-3975
Fax: 603-888-4585

SE AND MID-ATLANTIC

Tel: 321-951-4164
Fax: 321-951-4254

WEST COAST

Tel: 949-362-2260
Fax: 949-362-2266

CENTRAL

Tel: 719-594-8017
Fax: 719-594-8468

www.aeroflex.com info-ams@aeroflex.com

Aeroflex Colorado Springs, Inc. reserves the right to make changes to any products and services herein at any time without notice. Consult Aeroflex or an authorized sales representative to verify that the information in this data sheet is current before using this product. Aeroflex does not assume any responsibility or liability arising out of the application or use of any product or service described herein, except as expressly agreed to in writing by Aeroflex; nor does the purchase, lease, or use of a product or service from Aeroflex convey a license under any patent rights, copyrights, trademark rights, or any other of the intellectual rights of Aeroflex or of third parties.



Our passion for performance is defined by three attributes represented by these three icons: solution-minded, performance-driven and customer-focused