

# J384-Series Specifications (MIL-PRF-38534)



**8.89L x 7.37W x 4.32H (mm)**

PDI Model J384 series is a high reliability product designed, processed and tested in our Middleton facility and certified to MIL-PRF-38534H. This “J-Lead” product with hybrid assembly design and construction provides for superior long term reliability. Standard and custom frequencies are available and make this product ideal for Aerospace, Military, Avionic, Medical, and any other application requiring MIL-PRF-38534 certified content.

ex) **J384-T-25000X-O-C-D-3-R-X\***

\* - for standard or assigned for customization.

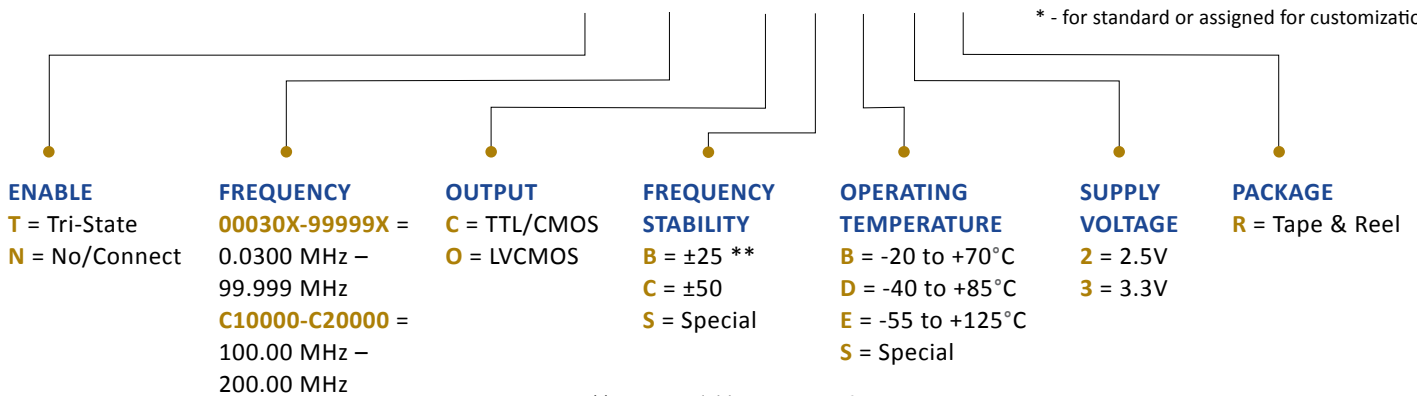

\*\* - Not available -55 to +125°C

Parameter		Units		
		3.3	2.5	V
Frequency Range*1		0.030000 to 200.000000		MHz
Frequency Stability*1	All Causes (Maximum) *2	Per Option		ppm
Temperature Range*1	Operating	Per Option		°C
	Storage	-55 to +125		°C
Supply Current (Maximum)	0.030000 to 23.999999 MHz	15	15	mA
	24.000000 to 49.999999 MHz	20	20	
	50.000000 to 69.999999 MHz	30	30	
	70.000000 to 200.000000 MHz	45	45	
Output Load		Per Option		
Duty Cycle (at 50% Vcc)		15pF/10 TTL Gates		
		40% to 60% (45% to 55% Option)		
Rise/Fall Times (Maximum)	Rise Time (10% to 90% Vcc)	8	7	ns
	Fall Time (90% to 10% Vcc)	8	7	
Start up Time (Maximum)		10		ms
Output Voltage Levels	High (Minimum)	90		% Vcc
	Low (Maximum)	10		
Pin 1 (Tri-State) (Option)	High (See below) or Open	Enable		
	Low (See below)*3	Disable		
	High Value (Minimum)	80		% Vcc
	Low Value (Maximum)*3	20		% Vcc
	Disable Current (Maximum)*3	10		uA
	Enable Delay Time (Maximum)	10		ms
	Disable Delay Time (Maximum)	150		ns

\*1 - Not all Frequency/Temperature/Voltage combinations are available.

\*2 - Inclusive of Tolerance @25°C, Operating Temperature, Supply Voltage, Load, Aging, Shock and Vibration.

\*3 - Internal crystal oscillation halted.

MIL-PRF-38534H , Class H Device Screening

Test or Inspection	MIL-STD-883		Requirement	Reference Paragraph
	Method	Condition		
Preseal Burn-In	1030		Optional	C.5.3
Non-Destructive Bond Pull	2023		Optional	C.5.4
Internal Visual	2017		100%	C.5.5
Temperature Cycling	1010	C , 10 Cycles	100%	C.5.6
Mechanical Shock or Constant Acceleration	2002 or 2001	B , (Y1 direction only) 3,000 G's (Y1 direction only)	100%	C.5.6
PIND	2020		Optional	C.5.7
Pre-Burn-In Electrical Test	IAW applicable device specification		Optional	C.5.8
Burn-In	1015		100%	C.5.9
Final Electrical Test	IAW applicable device specification		100%	C.5.10
Seal (Fine and Gross)	1014		100%	C.5.11
Radiographic	2012		Optional	C.5.12
External Visual Screen	2009		100%	C.5.13

# J384-Series 8.89 x 7.37 x 4.32 (mm)

## PACKAGE DIMENSIONS

Tolerance:  $\pm 0.008$  [.20mm] (Unless otherwise specified)

PIN	CONNECTION
1	Tri-State or No Connect
2	Ground/Case
3	Output
4	Supply Voltage

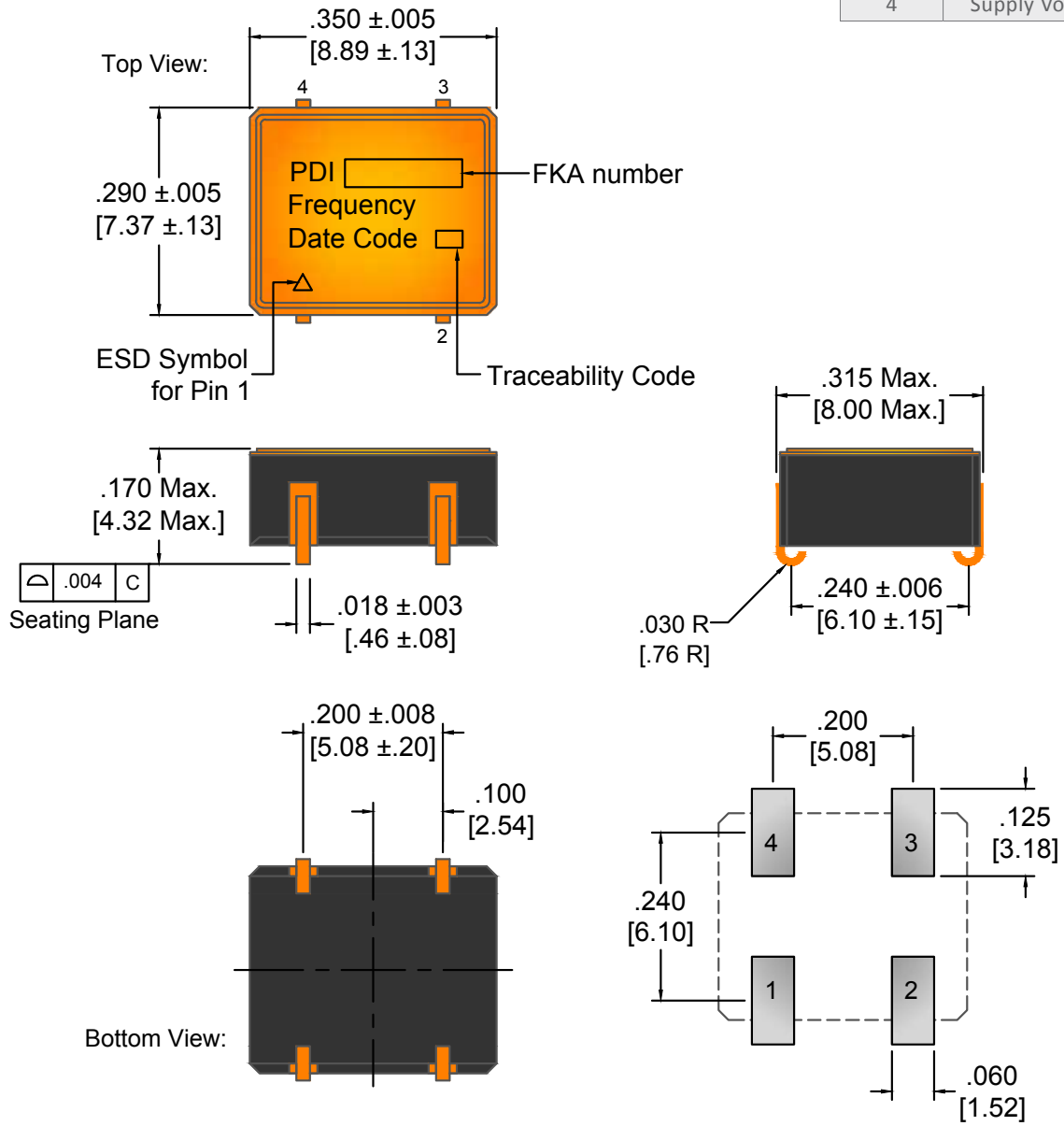

**NOTES:**

Other options are available, please consult factory.  
 All product is supplied RoHS and REACH compliant.  
 Product can be supplied on Tape and Reel, on reels of 1,000 units.  
 Specifications subject to change without notice, last updated 4/1/13.

# JL384-Series 8.89 x 7.37 x 4.32 (mm)

1. Material: Black Conductive Polystyrene or equivalent.
2. 10 Sprocket Hole pitch cumulative tolerance of  $\pm 0.008$ .
3. Camber in compliance with EIA 481.
4. Empty pockets: Trailing end (Minimum) 200 mm. and Leading end (Minimum) 400 mm.
5. Pocket position relative to sprocket hole measured as true position of pocket, not pocket hole.

