



Insulated Gate Bipolar Transistor

Features

- ❑ Low voltage drop at high currents
- ❑ Optimized for use with the Supertex SR03x Inductorless Off-Line Switcher
- ❑ Industry standard TO-252 (D-Pak) package
- ❑ 700V breakdown voltage rating

Applications

- ❑ White goods
- ❑ Small appliances
- ❑ Lighting controls
- ❑ Motor drives
- ❑ Meter readers
- ❑ Small off-line power supplies

Description

The Supertex GN2470 is a 700V, 3.5 amp insulated gate bipolar transistor (IGBT) that combines the positive aspects of both BJTs and MOSFETs.

The GN2470 IGBT has lower on-state voltage drop with high blocking voltage capabilities and features many desirable properties including a MOS input gate, low conduction voltage drop at high currents.

The GN2470 is designed to work with the Supertex SR03x inductorless dual output off-line regulators. See the SR03x datasheet for details.

Typical Application

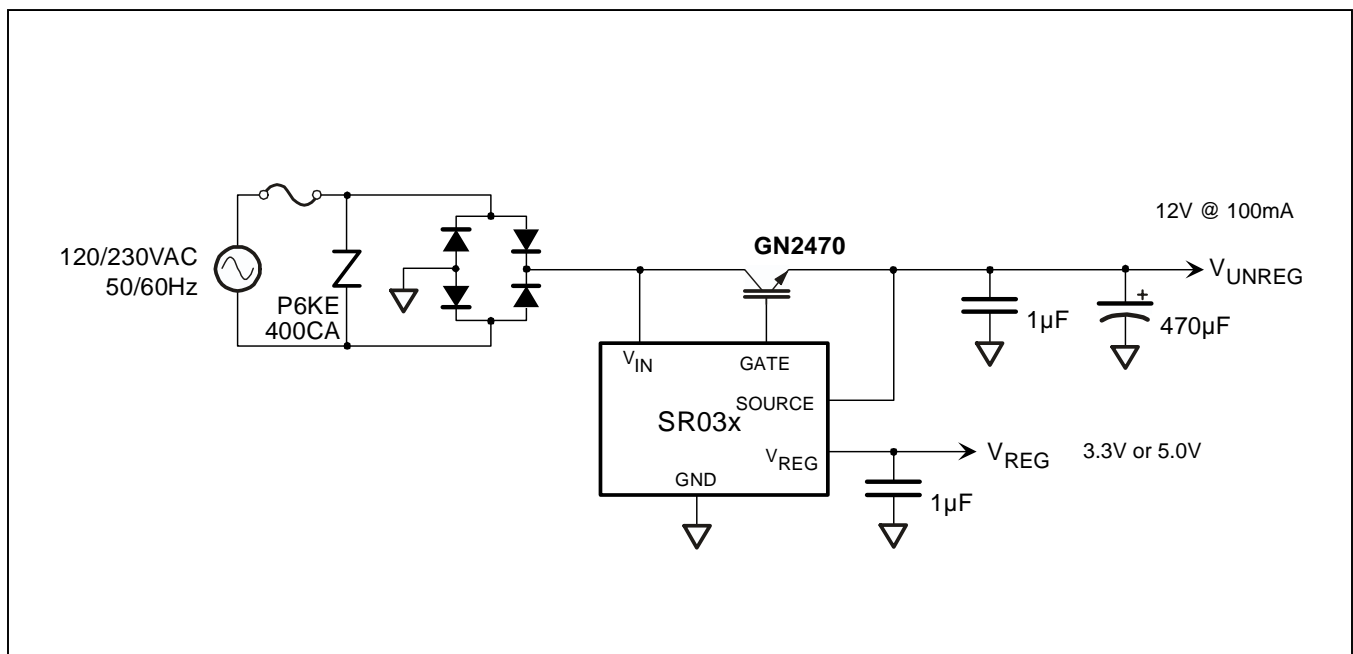

B042204

Ordering Information

Device	Package Options
	D-Pak*
GN2470	GN2470K4

* Only available in 2000 piece Tape & Reel

Absolute Maximum Ratings

Collector-to-Emitter Voltage	700V
Gate-to-Emitter Voltage	+/-20V
Operating Junction and Storage Temperature Range T_J and T_{STG}	-55°C to +150°C
Soldering Temperature*	300°C

*Distance if 1.6mm from case for 10 seconds.

Package Option

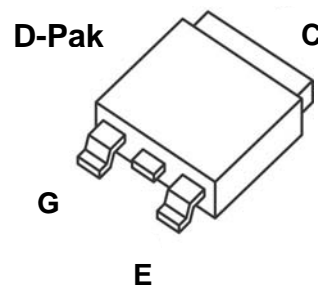

*Distance of 1.6mm from case for 10 seconds.

Thermal Characteristics

Package	Ic (continuous)	Ic (pulsed)	Power Dissipation @ $T_A = 25^\circ\text{C}$	θ_{ja} °C/W	θ_{jc} °C/W
D-Pak	1.0A	3.5A	2.5W	60*	10

*When mounted on FR4 board, 25mm x 25mm x 1.57mm

Electrical Characteristics (at $T_A=25^\circ\text{C}$, unless otherwise specified)

Symbol	Parameter	Min	Typ	Max	Units	Conditions
BV_{CES}	Collector-Emitter Breakdown Voltage	700	-	-	V	$V_{GE} = 0V, I_C = 250\mu\text{A}$
BV_{ECS}	Emitter-Collector Breakdown Voltage	-6	-10		V	$V_{GE} = 0V, I_C = 1\text{mA}$
$V_{GE(th)}$	Gate Threshold voltage	1.5	-	3.5	V	$V_{CE} = V_{GE}, I_C = 1\text{mA}$
V_{CE}	Collector-Emitter Voltage Drop	-	4.5	5.0	V	$I_C = 3A, V_{GE} = 13V$
g_{fe}	Forward Transconductance	0.5	0.8	-	mho	$V_{CE} = 25V, I_C = 2A$
I_{CES}	Zero Gate Voltage Collector Current	-	-	100	μA	$V_{GE} = 0V, V_{CE} = 600V$
I_{GES}	Gate-Emitter Leakage Current	-	-	± 100	nA	$V_{GE} = \pm 20V, V_{CE} = 0V$
$I_{C(on)}$	On-State Collector Current	3.0	4.0	-	A	$V_{GE} = 10V, V_{CE} = 25V$
$t_{d(on)}$	Turn-on delay time	-	8.0	15.0	ns	$V_{CC} = 25V$ $R_{GEN} = 25\Omega$ $R_L = 11\Omega$
t_r	Rise time	-	400	600	ns	
$t_{d(off)}$	Turn-off delay time	-	20	50	ns	
t_f	Fall Time	-	7000	12000	ns	
C_{ies}	Input Capacitance	-	100	150	pF	$V_{CE} = 25V$ $V_{GE} = 0V$ $f = 1\text{MHz}$
C_{oes}	Output Capacitance	-	12	25	pF	

C_{res}	Reverse Transfer Capacitance	-	2	5	pF	
-----------	------------------------------	---	---	---	----	--

Switching Waveforms and Test Circuit

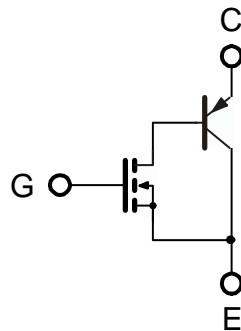
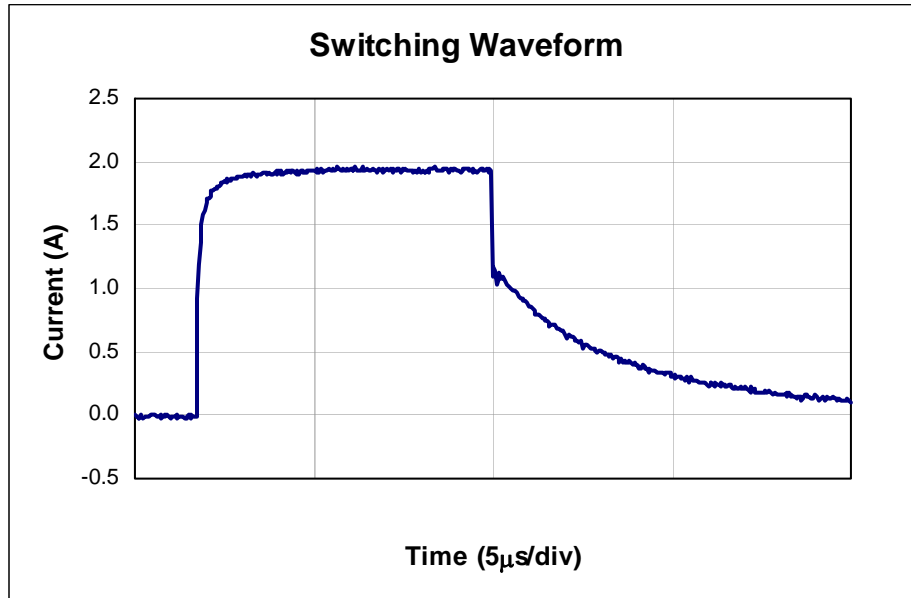
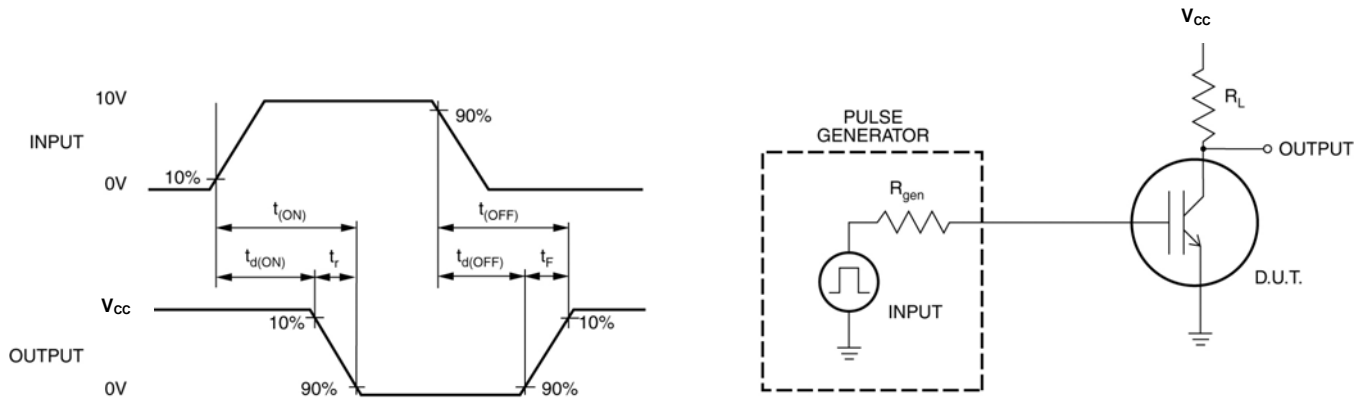

Equivalent Circuit

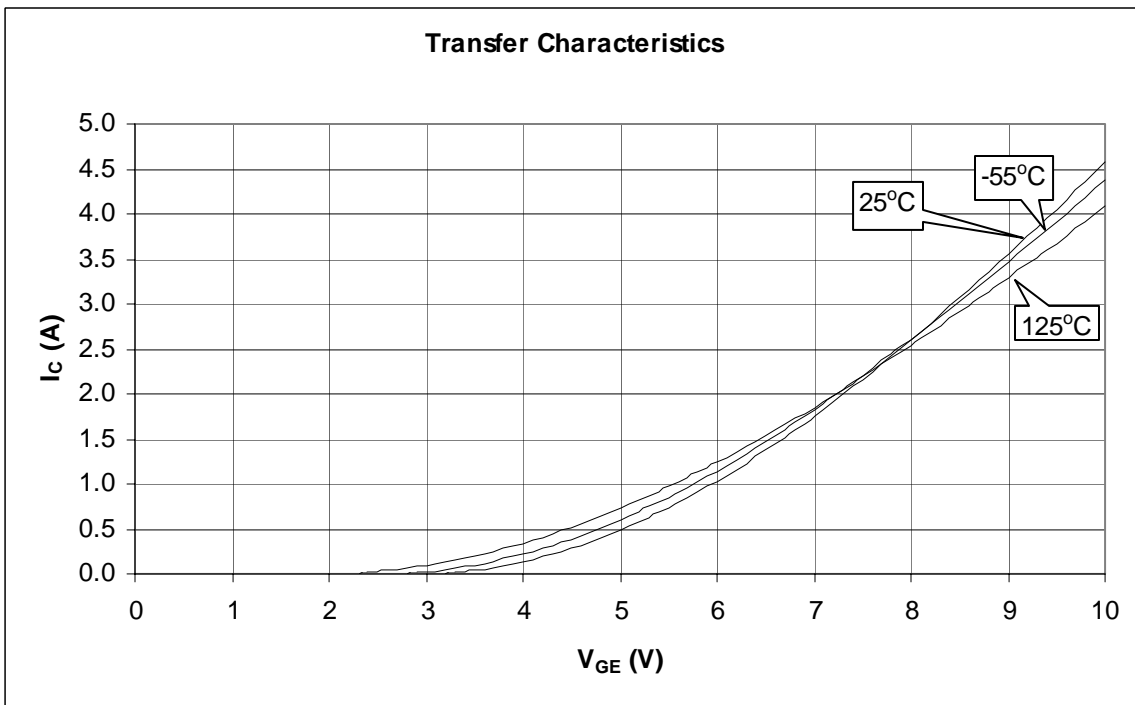
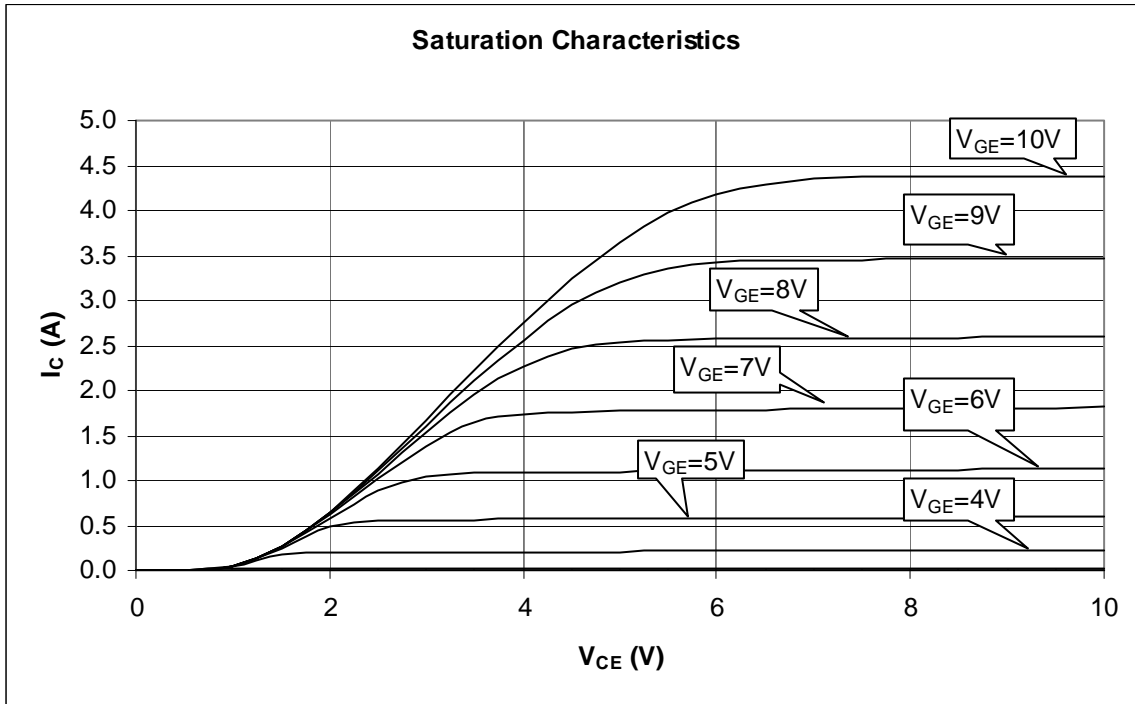

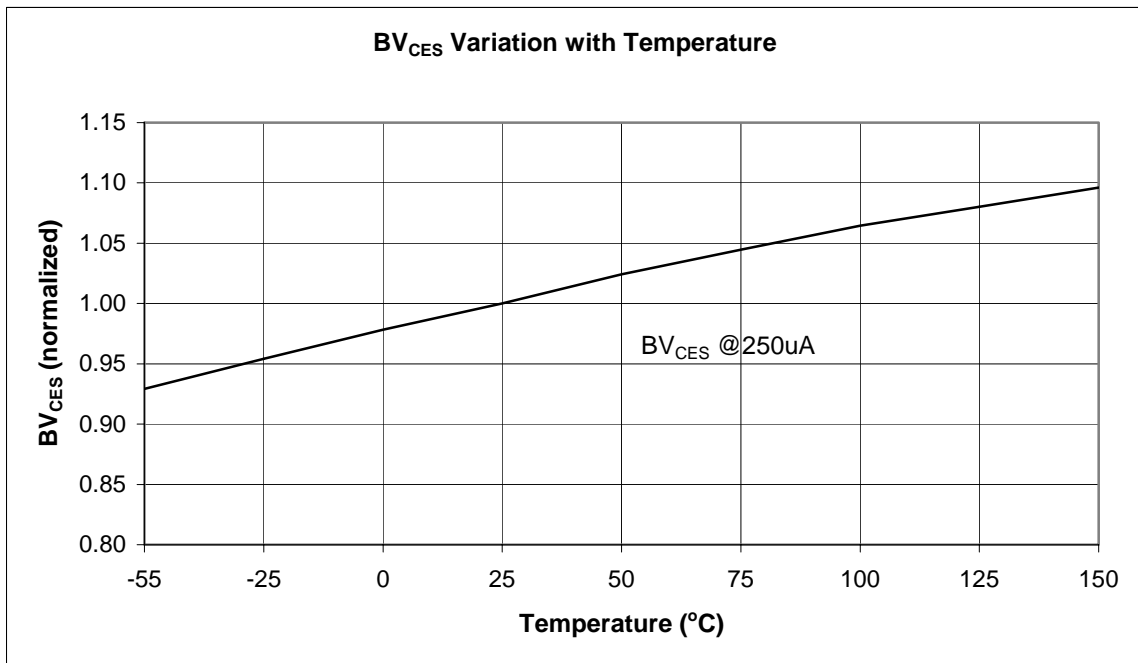
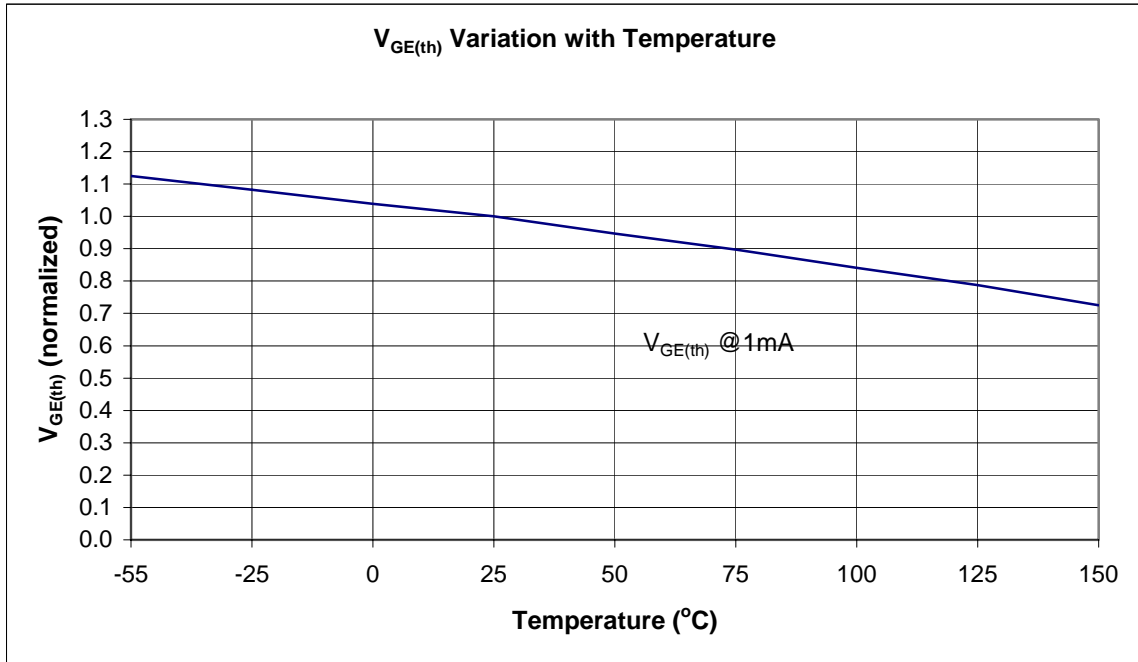

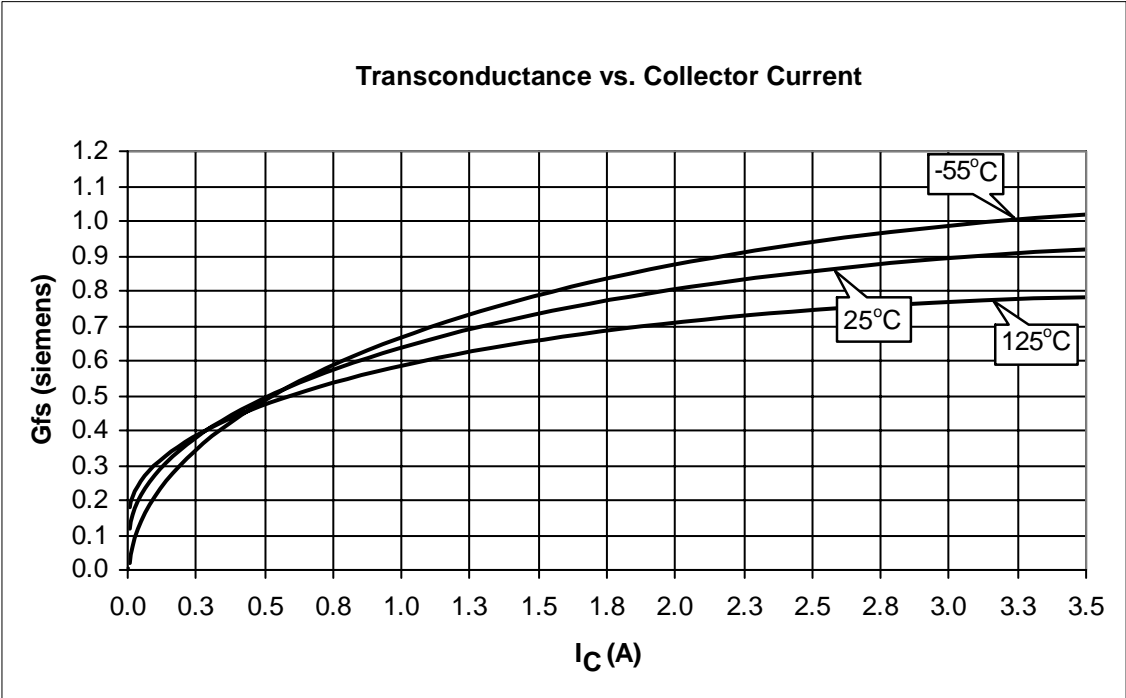

Application

Using the GN2470 IGBT in place of a MOSFET improves the performance of SR03x-based power supplies.

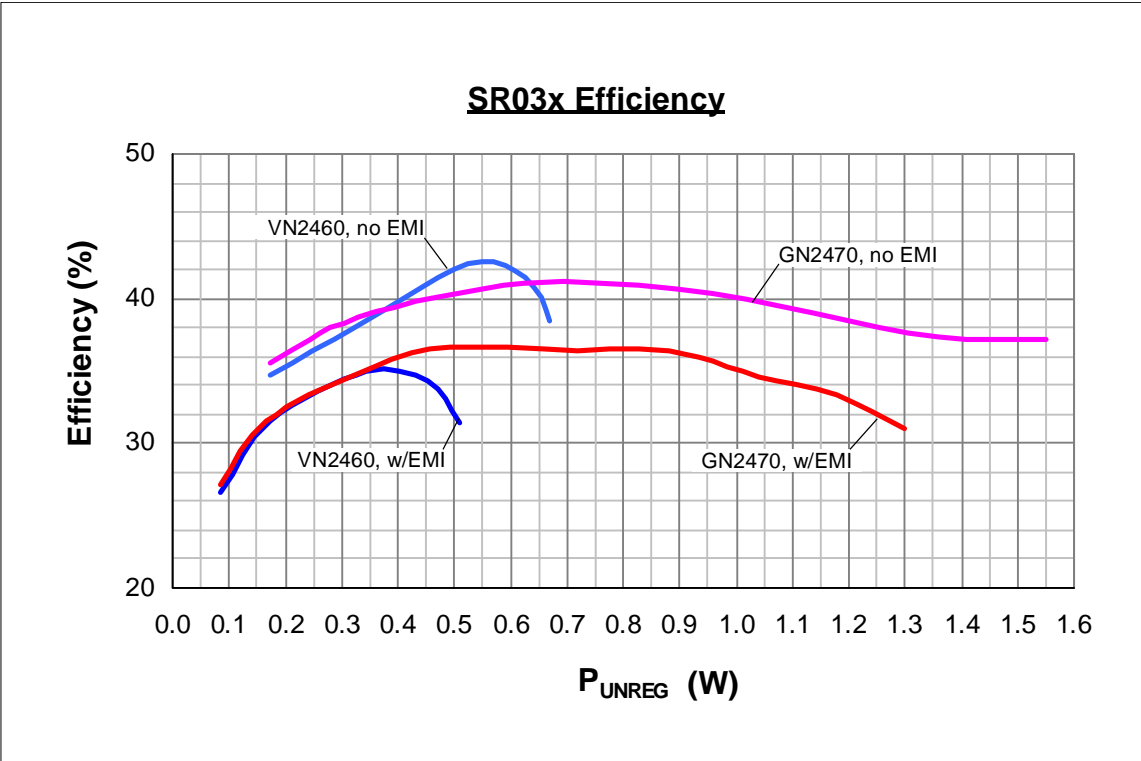

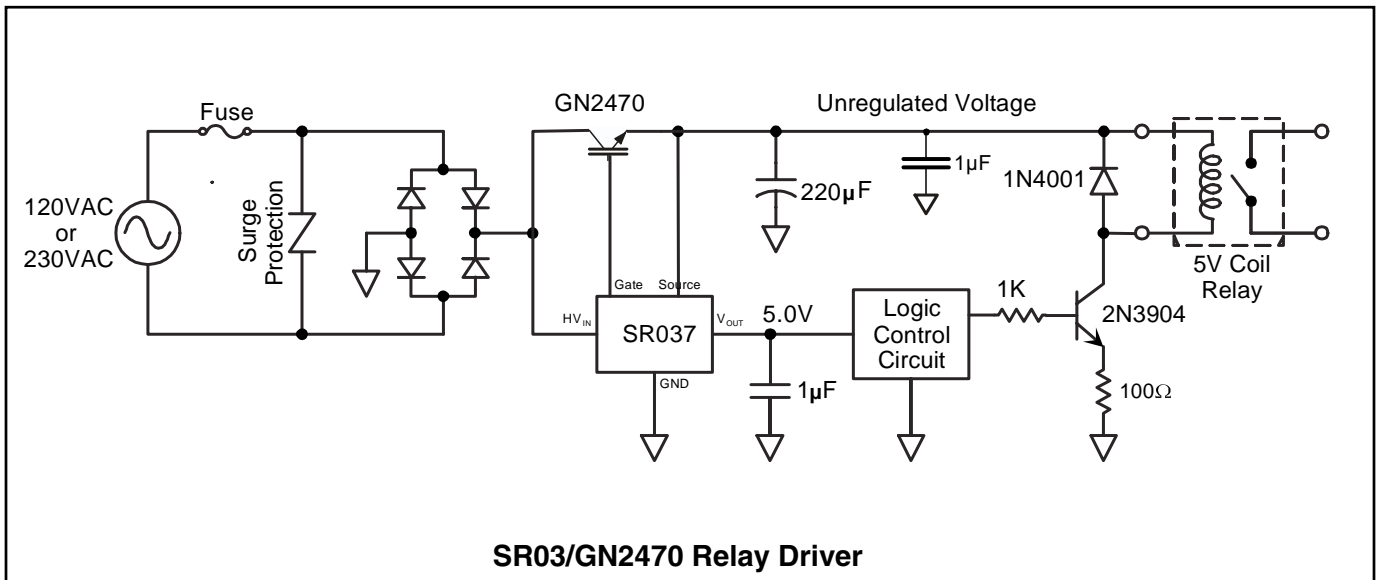
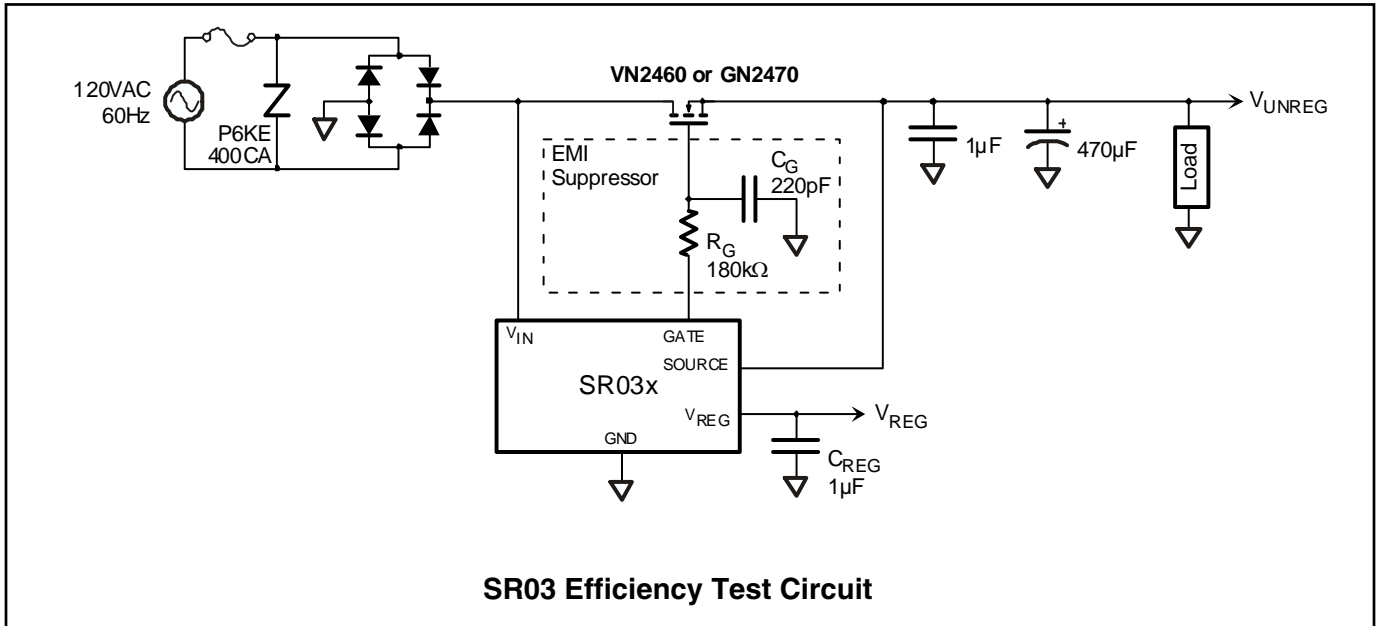

Supertex Inc. does not recommend the use of its products in life support applications and will not knowingly sell its products for use in such applications unless it receives an adequate "products liability indemnification insurance agreement." Supertex does not assume responsibility for use of devices described and limits its liability to the replacement of devices determined to be defective due to workmanship. No responsibility is assumed for possible omissions or inaccuracies. Circuitry and specifications are subject to change without notice. For the latest product specifications, refer to the Supertex website: <http://www.supertex.com>. For complete liability information on all Supertex products, refer to the most current databook or to the Legal/Disclaimer page on the Supertex website.