

Features

- Bi-Directional Power MOSFET Output Stage
- Extremely Low Output Leakage
- Optical Isolation
- Available to W and Y Mil-R-28750C Screening
- QPL Approved to DESC Drawing 89116

Applications

- Instrumentation
- Medical Electronics
- Process Controls
- Robotics
- Automatic Test Equipment
- Automotive
- Programmable Controllers, etc.

Description

The CT-100 series of bi-directional solid-state relays offer high current and low leakage for high performance switching. These relays are packaged in a low profile 6-pin mini-dip metal package. The operation and the electrical parameters are rated over the full military temperature range.

Back to back MOSFET outputs offer extremely low offset voltage and low On Resistance. Three versions are available to accommodate a wide range of switching applications. Optical coupling provides a high degree of isolation from inputs to outputs.

The CT-100 series of relays are manufactured using state of the art hybrid circuit technology to insure high reliability and low life cycle cost for critical applications.

Additional options of On Resistance and Output Voltage are available to meet specific application needs.



Relay Types

Part No.	Current	Voltage
CT-101 89116-006	1.0 Amp	80 Vdc
CT-102 89116-002	600 mA	180 Vdc
CT-103 89116-004	350 mA	350 Vdc

Pin Connections

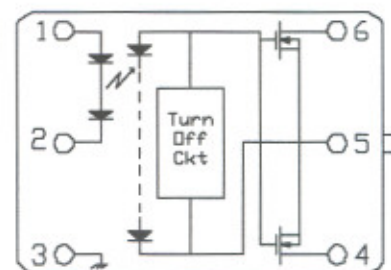

Inputs
1, 2

Outputs
4, 5, 6

Case
3

Electrical Specifications (-55° TO 120° AMBIENT TEMPERATURE UNLESS OTHERWISE NOTED)		CT-101		CT-102		CT-103		
OUTPUT (LOAD) SPECIFICATIONS Bi-Directional and AC Configurations (Pin 4 to Pin 6) (See Note 2)		Min	Max	Min	Max	Min	Max	Units
Continuous Load Current (See Fig. 4)			± 1.0		± 0.5		± 0.35	A _{dc}
Leakage Current @ V Load = max. operating voltage	-55°C < T _A < 25°C		± 200		± 200		± 200	nA _{dc}
	25°C < T _A < 120°C		± 20		± 20		± 20	uA _{dc}
Output Voltage Drop			± 0.75		± 1.0		± 2.4	V _{dc}
Continuous Operating Load Voltage			± 80		± 180		± 350	V _{dc}
Transient Blocking Voltage (5 S max.)			± 90		± 180		± 360	V _{dc}
ON Resistance R _{on} (on) at T _J = 25°C I Load = 100 mA _{dc} (See Fig. 4)			0.4		1.0		7.2	Ohms
Turn-On Time @ I _{in} = 25 mA (See Fig. 2 and 3)			800		800		500	us
Turn-Off Time (See Fig. 2)			500		500		500	us
Load Surge Current (See Note 3)			± 3.5		± 1.75		± 0.875	A _{dc}
dv/dt			100		100		100	V/us
Output Capacitance at 25 V _{dc} , 1 MHz			325		250		100	pF
DC Offset Voltage			100		100		100	uV
OUTPUT (LOAD) SPECIFICATIONS DC Configuration (Pins 4 and 6 connected together to Pin 5) (See Note 2)		Min	Max	Min	Max	Min	Max	Units
Continuous Load Current (See Fig. 4)			2.0		1.0		0.5	A _{dc}
Leakage Current @ V Load = max. operating voltage	-55°C < T _A < 25°C		400		400		400	nA _{dc}
	25°C < T _A < 120°C		40		40		40	uA _{dc}
Output Voltage Drop			0.4		0.5		1.8	V _{dc}
Continuous Operating Load Voltage			80		180		350	V _{dc}
Transient Blocking Voltage (5 S max.)			90		180		360	V _{dc}
ON Resistance R _{on} (on) at T _J = 25°C I Load = 100 mA _{dc} (See Fig. 4)			0.1		0.25		1.8	Ohms
Turn-On Time @ I _{in} = 25 mA (See Fig. 2 and ST 3)			800		800		500	us
Turn-Off Time (See Fig. 3)			500		500		500	us
dv/dt			7.0		3.5		1.75	A _{dc}
Output Capacitance at 25 V _{dc} , 1 MHz		100		100		100		V/us
DC Offset Voltage			650		500		200	pF
OUTPUT (LOAD) SPECIFICATIONS Alt Configurations		Min	Max	Min	Max	Min	Max	Units
Input to Output Capacitance			5		5			pF
Insulation Resistance @ 500 V _{dc}		10°		10°		10°		Ohms
Dielectric Strength		500		500		500		V _{ac}
Output Junction Temperature @ I Load = max. rated current		125		125		125		°C
Maximum Junction Temperature T _J (max)			150		150		150	°C
Thermal Resistance Junction to Ambient θ_{JA}			110		110		110	°C/W
Thermal Resistance Junction to Case θ_{JC}			20		20		20	°C/W

INPUT (CONTROL) CHARACTERISTICS (SEE NOTE 1)		MIN	TYP	MAX	UNITS
RATED INPUT CURRENT			25		mA _{dc}
INPUT VOLTAGE DROP AT 25 mA				3.25	V _{dc}
Continuous Input	-55°C < T _A < 105°C	10		50	mA _{dc}
	105°C < T _A < 120°C	10		25	mA _{dc}
Reverse Voltage Protection				-5	V _{dc}
Input Current (Guaranteed On)		10			mA
Input Current (Guaranteed Off)				10	mA
Turn-Off Voltage				1.5	V _{dc}

ENVIRONMENTAL SPECIFICATIONS		
Temperature Range	Operating	-55°C + 120°C
	Storage	-55°C + 125°C
Vibration		100g, 10 to 3000 Hz
Constant Acceleration		5000 g.
Shock		1500 g, 0.5 ms pulse

Output Configurations

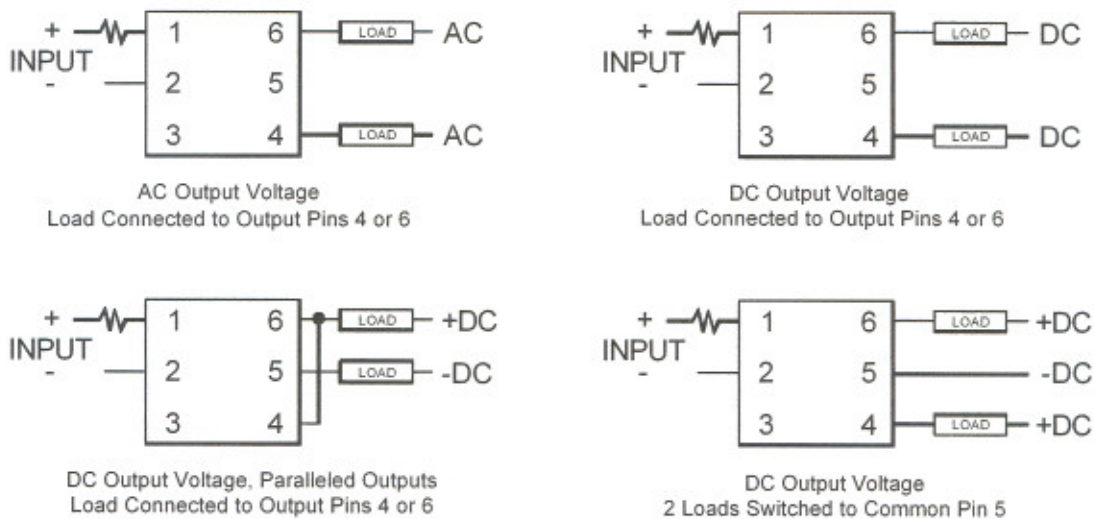

Figure 1

Output Switching Times

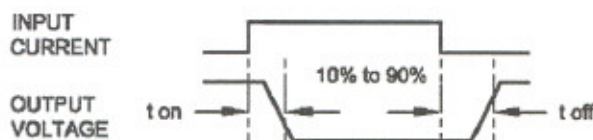

Figure 2

Input Current vs Turn-On Time

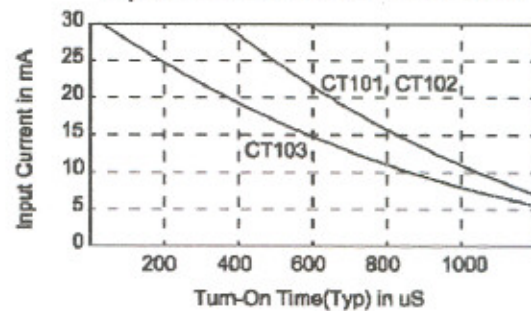

Figure 3

Load Current vs Operating Temperature

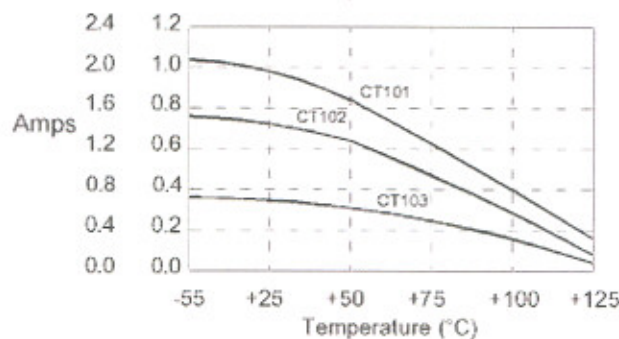
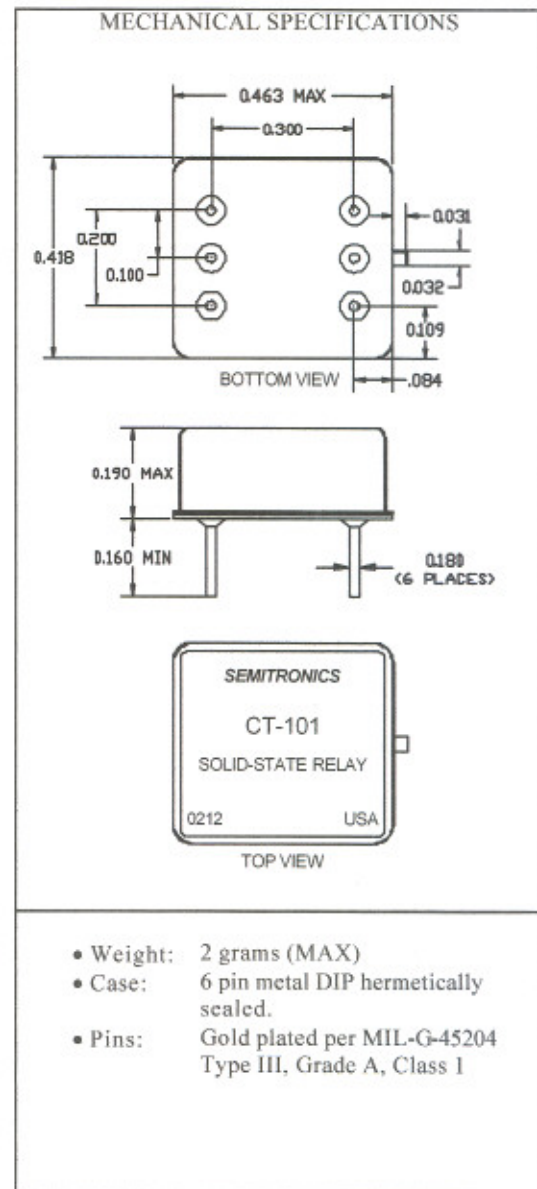
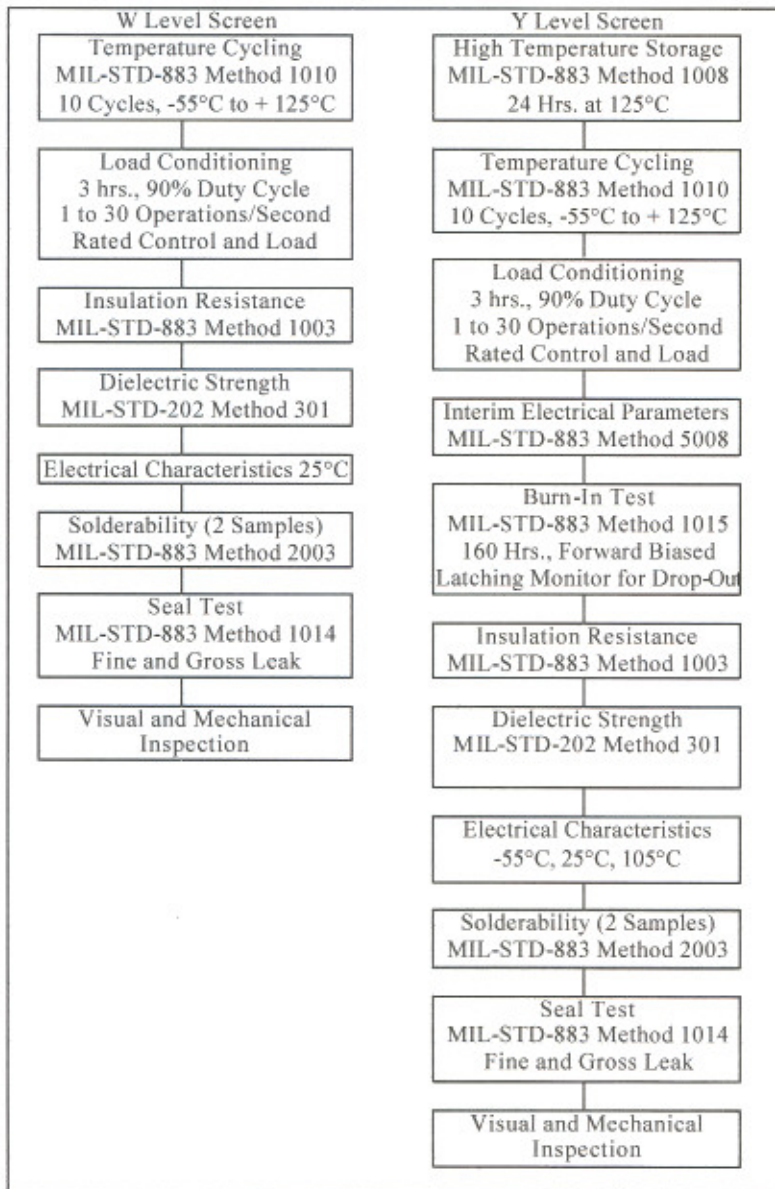

Figure 4



NOTES

- Series resistor required limiting input current to 50 mA max.
- The rated input current is 25 mA for all tests unless otherwise specified.
- Surge current is specified for 25°C, 10 cycles maximum at a 1 Hz repetition rate with 10% duty cycle and 0.1 s. duration.
- Relays may drive loads connected to either positive or negative referenced power supply lines. Inductive loads must be diode suppressed.
- ON resistance of each pole is 1/2 of the ON resistance in the bi-directional configuration. Low side switching can only be accommodated by this configuration.
- Continuous load current is rated under the condition of still air.
- Maximum leakage current for junction temperatures above 60°C can be determined by this formula:

$$IL (\text{leak}) \leq 2 \times 10^{(T_j/30)} \text{ (in nA)}$$