

Single/Dual/Triple E3/DS3/STS-1 Line Interface Unit

Data Sheet

CX28331/CX28332/CX28333 (-1x)

Revision History

Revision	Level	Date	Description
A	—	2/2003	Initial Release [Document number 28333-DSH-001-A] Updated LBO to 450 feet Incorporated Errata #500371A Removed CX2833i-3x information (see prior document) Removed EVM, IBIS, and JAT Appendices Fixed description of transmit AIS during loopback operations Added loopback diagrams Updated PCB design considerations Added power sequencing requirements General corrections

© 2002, 2003 Mindspeed Technologies™, a Conexant business
All Rights Reserved.

Information in this document is provided in connection with Mindspeed Technologies ("Mindspeed") products. These materials are provided by Mindspeed as a service to its customers and may be used for informational purposes only. Mindspeed assumes no responsibility for errors or omissions in these materials. Mindspeed may make changes to specifications and product descriptions at any time, without notice. Mindspeed makes no commitment to update the information and shall have no responsibility whatsoever for conflicts or incompatibilities arising from future changes to its specifications and product descriptions.

No license, express or implied, by estoppel or otherwise, to any intellectual property rights is granted by this document. Except as provided in Mindspeed's Terms and Conditions of Sale for such products, Mindspeed assumes no liability whatsoever.

THESE MATERIALS ARE PROVIDED "AS IS" WITHOUT WARRANTY OF ANY KIND, EITHER EXPRESS OR IMPLIED, RELATING TO SALE AND/OR USE OF MINDSPEED PRODUCTS INCLUDING LIABILITY OR WARRANTIES RELATING TO FITNESS FOR A PARTICULAR PURPOSE, CONSEQUENTIAL OR INCIDENTAL DAMAGES, MERCHANTABILITY, OR INFRINGEMENT OF ANY PATENT, COPYRIGHT OR OTHER INTELLECTUAL PROPERTY RIGHT. MINDSPEED FURTHER DOES NOT WARRANT THE ACCURACY OR COMPLETENESS OF THE INFORMATION, TEXT, GRAPHICS OR OTHER ITEMS CONTAINED WITHIN THESE MATERIALS. MINDSPEED SHALL NOT BE LIABLE FOR ANY SPECIAL, INDIRECT, INCIDENTAL, OR CONSEQUENTIAL DAMAGES, INCLUDING WITHOUT LIMITATION, LOST REVENUES OR LOST PROFITS, WHICH MAY RESULT FROM THE USE OF THESE MATERIALS.

Mindspeed products are not intended for use in medical, lifesaving or life sustaining applications. Mindspeed customers using or selling Mindspeed products for use in such applications do so at their own risk and agree to fully indemnify Mindspeed for any damages resulting from such improper use or sale.

The following are trademarks of Conexant Systems, Inc.: Mindspeed Technologies™, the Mindspeed™ logo, and "Build It First"™. Product names or services listed in this publication are for identification purposes only, and may be trademarks of third parties. Third-party brands and names are the property of their respective owners.

For additional disclaimer information, please consult Mindspeed Technologies Legal Information posted at www.mindspeed.com which is incorporated by reference.

CX28331/CX28332/CX28333 (-1x)

Single/Dual/Triple E3/DS3/STS-1 Line Interface Unit

The CX28333 is a three-channel, DS3/E3/STS-1, fully integrated Line Interface Unit (LIU) device. It is configured via external pins and does not require a microprocessor interface. Each channel has an independent receive equalizer requiring no user configuration. Additionally, each channel has a programmable transmit pulse shaper that can be set to ensure that the transmit pulse meets the pulse mask requirement for the digital cross-connect. The CX28332 is a dual-channel, and the CX28331 is a single-channel LIU with performance identical to the CX28333.

The CX28333 gives the user new economies of scale in concentrator applications where three DS3 or STS-1 channels are concentrated into a single STS-3 channel.

Each line interface is reduced to 1:1 coupling transformers, terminating resistors, and a capacitor.

NOTE: In this document, "i" is used to represent the number of channels:
i = 1 (CX28331), i = 2 (CX28332), and i = 3 (CX28333).

Functional Block Diagram

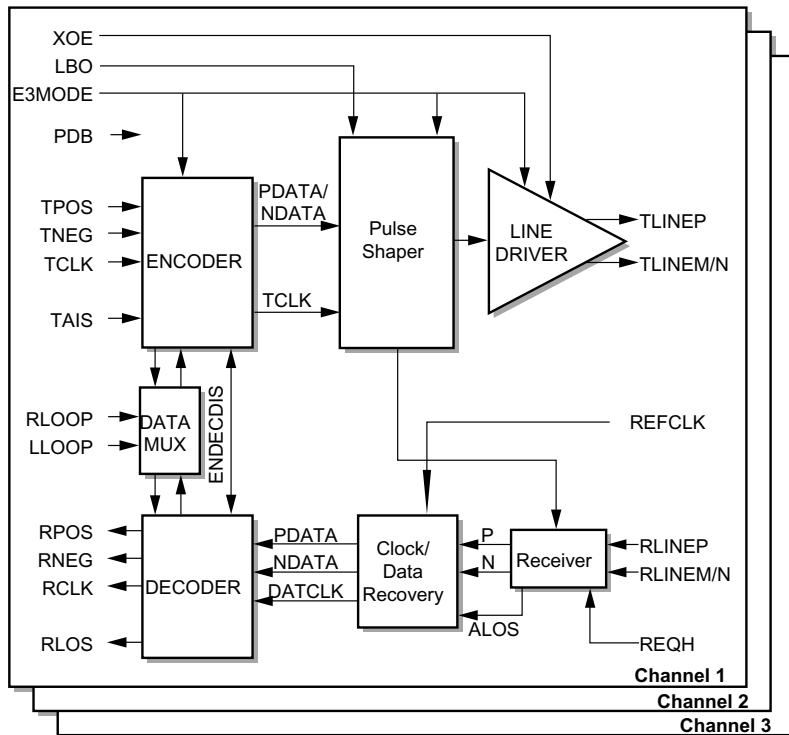

Distinguishing Features

- Programmable pulse shaper to meet cross-connect pulse masks (ANSI T1.102-1993)
- Meets jitter tolerance and jitter generation specifications of Bellcore GR499, GR253 and ETSI TBR24
- Alarms for coding violation and loss of signal
- Full diagnostic loopback capability
- Uses a minimum of external components
- Compliant with ITU-G.703 and ETSI TBR24
- Independent power down mode per channel
- Easily interfaced to the DS3/E3 Framer IC (CX28342/3/4/6/8 and CN8330)
- Selectable B3ZS/HDB3 encoding/decoding

Physical Characteristics

- 80-pin ETQFP package
- Single 3.3 V power supply
- 1 W maximum power dissipation (CX28333)
- - 40 °C to +85 °C temperature range
- 5 V-tolerant pins
- TTL digital pins

Applications

- Digital Cross-Connect Systems
- Routers
- ATM Switches
- Channelized Line Aggregation Units
- Test Equipment
- Channel Service Units
- Multiplexers

CX28333EVM

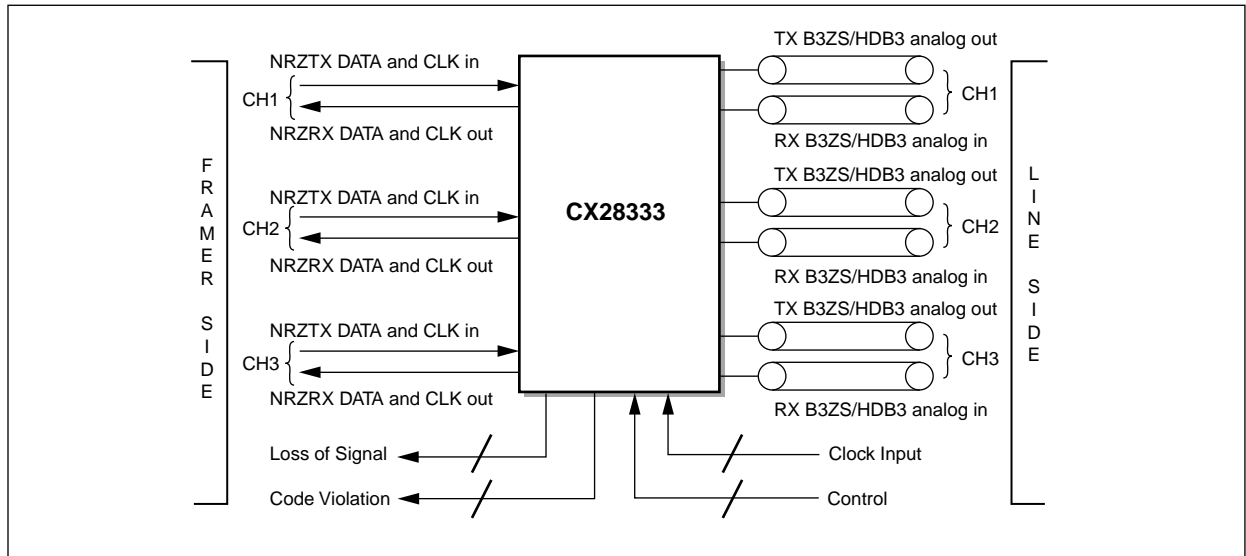

100985_002

Ordering Information

Model Number	Package	Description	Operating Temperature
CX28331-1x	80-Pin ETQFP	Single-channel LIU	-40 °C to +85 °C
CX28332-1x	80-Pin ETQFP	Dual-channel LIU	-40 °C to +85 °C
CX28333-1x	80-Pin ETQFP	Triple-channel LIU	-40 °C to +85 °C

Table of Contents

Table of Contents	v
List of Figures	vii
List of Tables	ix
1.0 Pin Description	1-1
1.1 Pin Assignments	1-1
2.0 Functional Description	2-1
2.1 Overview	2-1
2.2 Transmitter	2-3
2.2.1 AMI B3ZS/HDB3 Encoder	2-3
2.2.2 Pulse Shaper	2-3
2.2.3 Line Driver	2-4
2.2.3.1 Transmit Pulse Mask Templates	2-5
2.2.4 Alarm Indication Signal (AIS) Generator	2-8
2.2.5 Jitter Generation (Intrinsic)	2-8
2.3 Receiver	2-9
2.3.1 Receive Sensitivity	2-9
2.3.2 AGC/VGA Block	2-9
2.3.3 Receive Equalizer	2-9
2.3.4 The PLL Clock Recovery Circuit	2-10
2.3.5 Loss Of Signal (LOS) Detector	2-10
2.3.6 B3ZS/HDB3 Decoder With Bipolar Violation Detector	2-10
2.3.7 Data Squelching	2-11
2.4 Jitter Tolerance	2-11
2.4.1 Jitter Transfer	2-13
2.5 Additional CX2833i Functions	2-14
2.5.1 Bias Generator	2-14
2.5.2 Power-On Reset (POR)	2-14
2.5.3 Loopback Multiplexers (MUXes)	2-14
2.6 Mechanical Specifications	2-17

2.7	Electrical Characteristics	2-18
2.7.1	Absolute Maximum Ratings	2-18
2.7.2	ESD Ratings	2-19
2.7.3	Recommended Operating Conditions	2-19
2.8	DC Characteristics	2-20
2.9	AC Characteristics	2-21
3.0	Applications	3-1
3.1	PCB Design Considerations for the CX2833i	3-1
3.1.1	Power Supply and Ground Plane	3-1
3.1.2	Component Placement	3-1
3.1.2.1	RBIAS Resistor	3-1
3.1.2.2	VGG Decoupling	3-2
3.1.2.3	Termination Resistors and Capacitors	3-2
3.1.3	Impedance Matching	3-2
3.1.4	Other Passive Parts	3-2
3.1.5	IBIS Models	3-2
3.1.6	Recommended Vendors	3-3
Appendix A: Applicable Standards		A-1
Appendix B: Exposed Thin Quad Flat (ETQFP) Pack		B-1
B.1	Introduction	B-2
B.2	Package Thermal Characterization	B-3
B.2.1	Heat Removal Path	B-3
B.2.2	Thermal Lands	B-3
B.2.3	PCB Design	B-5
B.2.4	Thermal Test Structure	B-6
B.2.4.1	Test Environment	B-6
B.2.4.2	Thermal Test Boards	B-6
B.2.5	Package Thermal Performance	B-7
B.2.5.1	Calculation Guidelines	B-7
B.2.5.2	Package Thermal Resistance	B-7
B.3	Solder Stencil Determination	B-9
B.4	Solder Reflow Profile	B-9
Appendix C: Power Sequencing		C-1

List of Figures

Figure 1-1.	CX28331-1x Pin Diagram	1-2
Figure 1-2.	CX28332-1x Pin Diagram	1-3
Figure 1-3.	CX28333-1x Pin Diagram	1-4
Figure 2-1.	Typical Application Of Single CX2833i Channel	2-2
Figure 2-2.	Pulse Shaper	2-3
Figure 2-3.	Pulse Measurement Points	2-4
Figure 2-4.	Transmit Pulse Mask for DS3 Rates	2-5
Figure 2-5.	Transmit Pulse Mask for STS-1 Rates	2-6
Figure 2-6.	Transmit Pulse Mask for E3 Rate	2-7
Figure 2-7.	AIS Signal	2-8
Figure 2-8.	Minimum Jitter Tolerance Requirement	2-12
Figure 2-9.	Maximum Jitter Transfer Curve Requirement	2-13
Figure 2-10.	Remote Loopback Diagram	2-15
Figure 2-11.	Local Loopback Diagram	2-16
Figure 2-12.	CX2833i-1x Mechanical Drawing (80-Pin)—Dimensions	2-17
Figure 2-13.	Timing Diagram	2-22
Figure 3-1.	DS3/E3 Application Diagram	3-4
Figure B-1.	Schematic Representation of the Package Components	B-2
Figure B-2.	Package and PCB Land Configuration	B-3
Figure B-3.	Internal Structure for a Two-Layer PCB	B-5
Figure B-4.	Internal Structure For a Six-Layer PCB	B-5
Figure B-5.	Test Performance Structure (A = 100 mm, B = 100 mm, L _P = 1.40 mm, L _B = 1.60 mm)	B-6
Figure B-6.	Package Thermal Resistance as a Function of Airflow Velocity for a 48-ETQFP Package	B-7
Figure B-7.	Package Thermal Resistance as a Function of Airflow Velocity for an 64 ETQFP	B-8
Figure B-8.	Package Thermal Resistance as a Function of Airflow Velocity for an 80 ETQFP	B-8
Figure B-9.	Typical IR Reflow Profile for Eutectic Sn63:Pb37	B-10
Figure B-10.	Typical Forced Convection Reflow Profile for Eutectic Sn63:Pb37	B-11
Figure C-1.	Power -up sequence of VGG and VDD	C-1
Figure C-2.	Power-down sequence of VGG and VDD	C-1

List of Tables

Table 1-1.	CX2833i-1x Pin Definitions	1-5
Table 2-1.	DS3 Transmit Template Specifications	2-5
Table 2-2.	STS-1 Transmit Template Specifications	2-6
Table 2-3.	RLOS Threshold Settings	2-10
Table 2-4.	Absolute Maximum Ratings	2-18
Table 2-5.	ESD Ratings	2-19
Table 2-6.	Recommended Operating Conditions	2-19
Table 2-7.	DC Characteristics	2-20
Table 2-8.	AC Characteristics (Logic Timing)	2-21
Table B-1.	Dimensional Parameters (mm)	B-4
Table B-2.	Specification for a Two-Layer Test Board	B-6
Table B-3.	Specification for a Four-Layer Test Board	B-6
Table B-4.	Specification for Delco Thermal Test Chips	B-7
Table B-5.	Test Conditions	B-8

1.0 Pin Description

1.1 Pin Assignments

Figures 1-1 (CX28331-1x), 1-2 (CX28332-1x), and 1-3 (CX28333-1x) illustrate pin assignments for the 80-pin Exposed Thin Quad Flat Package (ETQFP). See Table 1-1 for the CX2833i-1x pin descriptions.

The input/output (I/O) column is coded as follows:

I = Input
O = Output
I/O = Bidirectional
P = Power

NOTE: All digital inputs and outputs contain 75 k Ω pull-down resistors.

When a channel is disabled (i.e., the $\overline{\text{PDx}}$ pin is tied low or not connected), all receive and transmit analog circuitry powers down. Analog inputs (RLINE) are ignored and analog outputs (TLINE) are high impedance. Digital inputs of a powered-down channel are still active, but ignored. Overall noise on the device can be lowered by not driving the digital inputs of a powered-down channel.

NOTE: When power is disconnected from the device, TLINE pins are low impedance to ground if driven by more than one forward-bias diode voltage (0.7 V) below ground. Additionally, driving TLINE, a forward-bias diode voltage above the VGG pin, creates a low impedance path from the TLINE pin to the VGG pin. Otherwise, the TLINE pins are high impedance.

Figure 1-1. CX28331-1x Pin Diagram

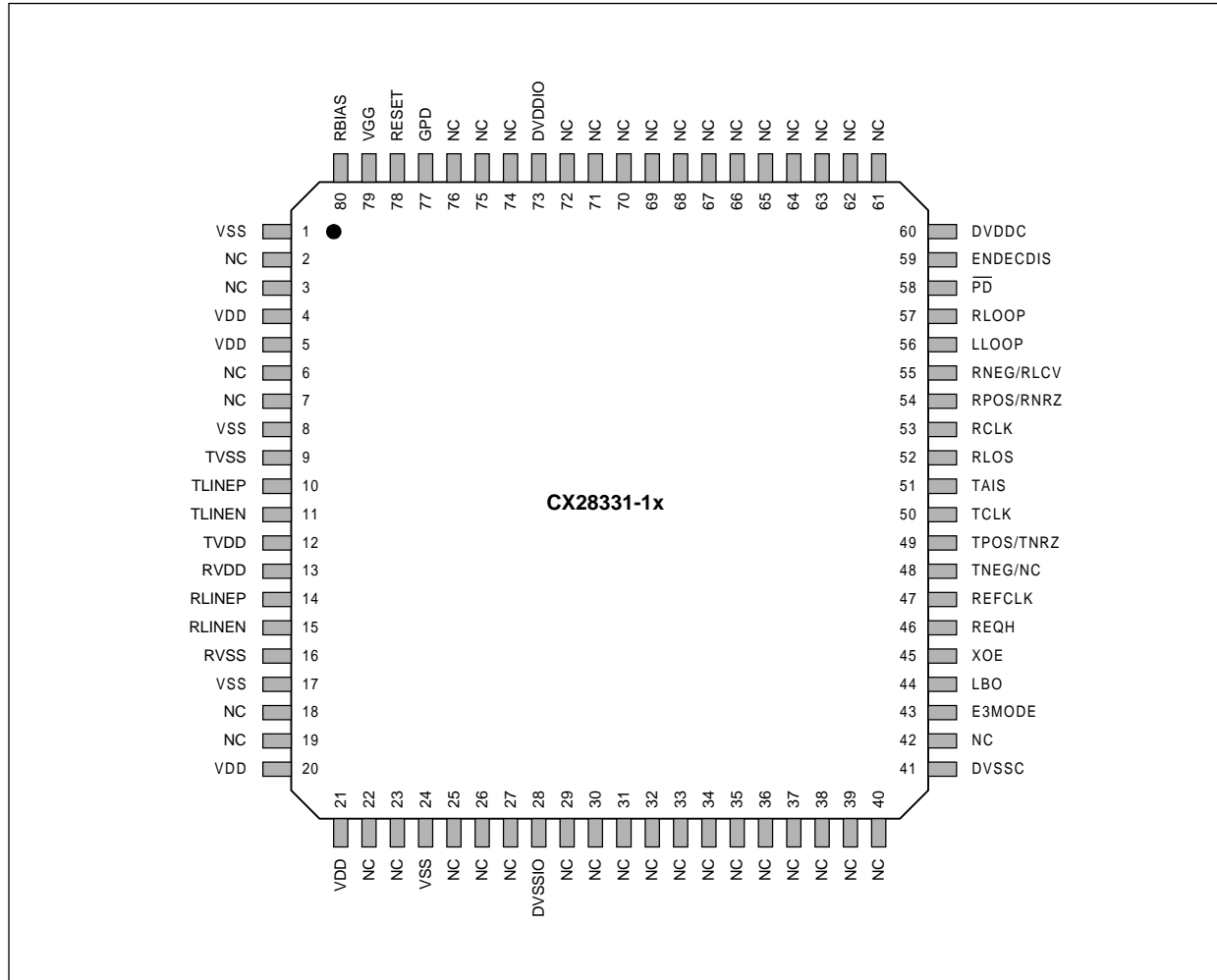

100985_003

Figure 1-2. CX28332-1x Pin Diagram

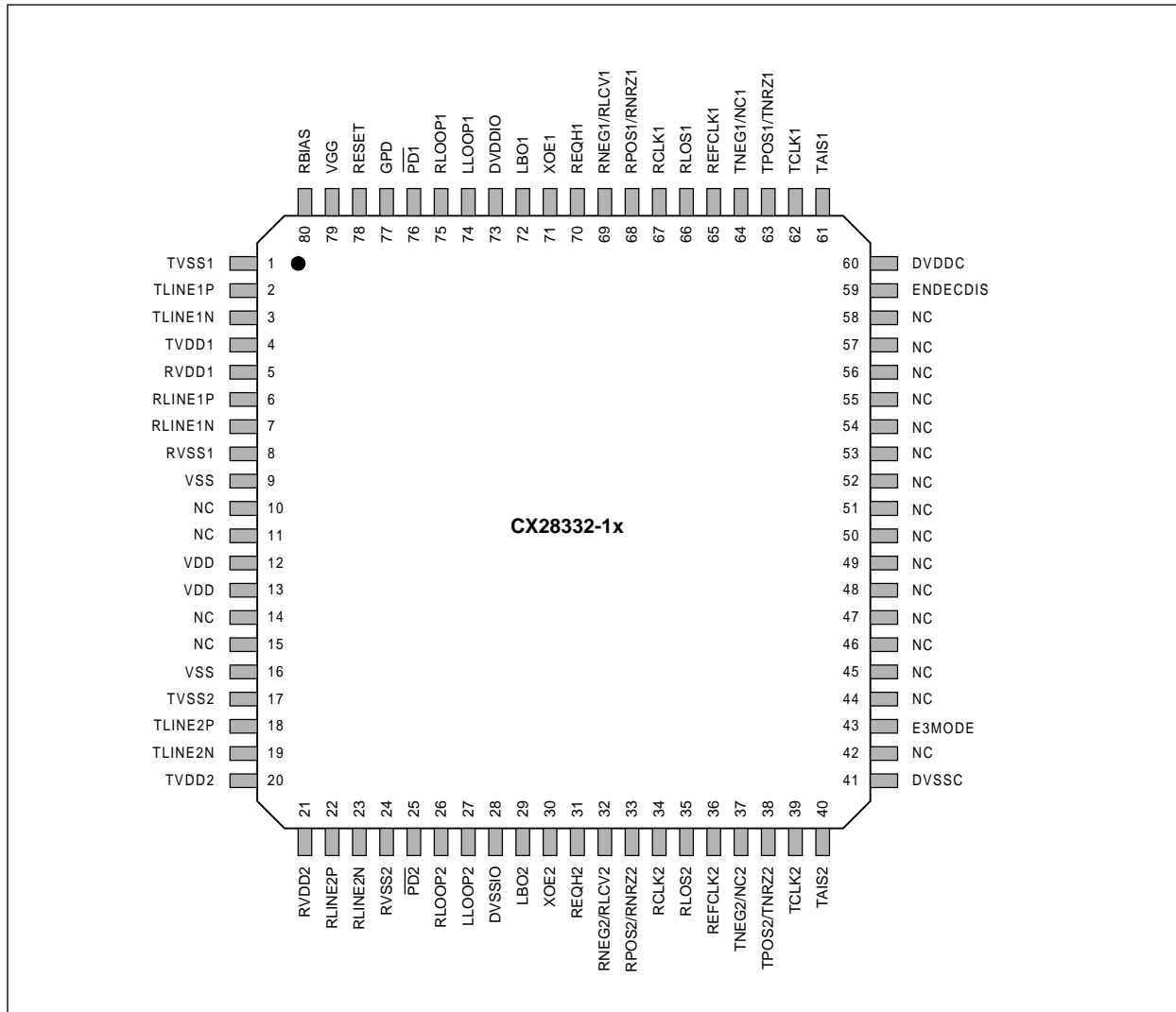

100985_004

Figure 1-3. CX28333-1x Pin Diagram

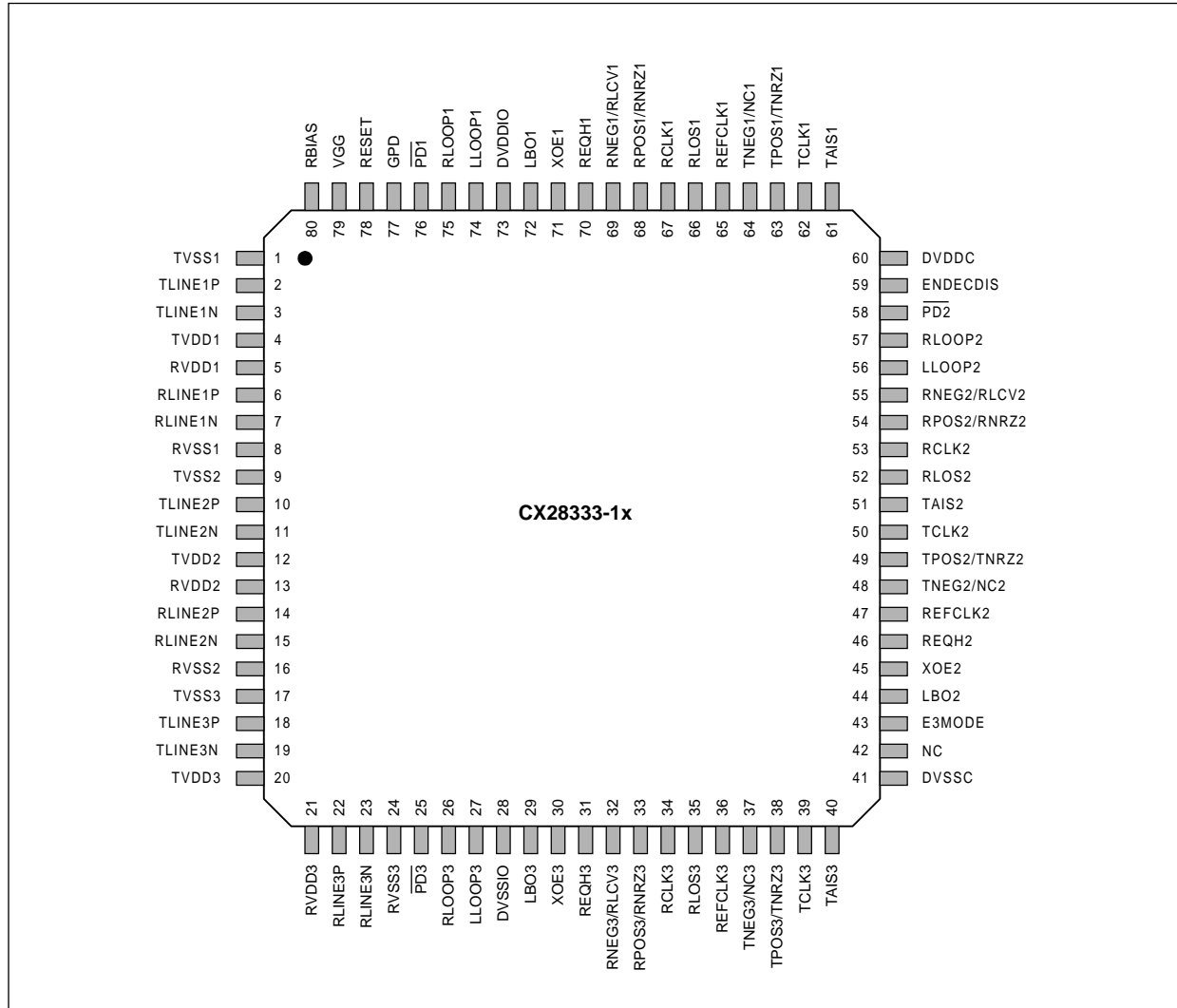

100985_005

Table 1-1. CX2833i-1x Pin Definitions (1 of 7)

Pin #			Signal Name	Description	I/O/P	Notes	
CX28331-1x	CX28332-1x	CX28333-1x					
Coaxial Line Pins							
14	—	—	RLINEP	Ch1 positive receive data	I	Differential inputs for each channel from its respective receive coax line. The RX expects balanced differential inputs, usually achieved using a 1:1 transformer. The inputs are internally DC biased to 1.9 V.	
—	6	6	RLINE1P				
15	—	—	RLINEN	Ch1 negative receive data	I		
—	7	7	RLINE1N				
—	22	14	RLINE2P	Ch2 positive receive data	I		
—	23	15	RLINE2N	Ch2 negative receive data	I		
—	—	22	RLINE3P	Ch3 positive receive data	I		
—	—	23	RLINE3N	Ch3 negative receive data	I		
10	—	—	TLINEP	Ch1 positive transmit data	O		Differential, coax-driver balanced outputs for pulse-shaped AMI B3ZS/HDB3 encoded waveforms for each channel. These pins should be connected to the primary side of the 1:1 transformer through two backmatch resistors, refer to Figure 3-1 .
—	2	2	TLINE1P				
11	—	—	TLINEN	Ch1 negative transmit data	O		
—	3	3	TLINE1N				
—	18	10	TLINE2P	Ch2 positive transmit data	O		
—	19	11	TLINE2N	Ch2 negative transmit data	O		
—	—	18	TLINE3P	Ch3 positive transmit data	O		
—	—	19	TLINE3N	Ch3 negative transmit data	O		

Table 1-1. CX2833i-1x Pin Definitions (2 of 7)

Pin #			Signal Name	Description	I/O/P	Notes
CX28331-1x	CX28332-1x	CX28333-1x				
Digital Data Pins						
54	—	—	RPOS/ RNRZ	Ch1 receive Positive rail or NRZ data	0	Resynchronized receive data intended to be strobed out by the corresponding RCLK. When ENDECDIS = 1, these outputs are positive and negative AMI data (RPOS and RNEG).
—	68	68	RPOS1/ RNRZ1			
55	—	—	RNEG/ RLCV	Ch1 receive Negative rail or line code violation	0	When ENDECDIS = 0, these outputs are decoded NRZ data (RNRZ) and line code violation (RLCV). A line code violation is indicated when RLCV = 1.
—	69	69	RNEG1/ RLCV1			
—	33	54	RPOS2/ RNRZ2	Ch2 receive Positive rail or NRZ data	0	See notes on the ENDECDIS pin in the Control Signals section.
—	32	55	RNEG2/ RLCV2	Ch2 receive Negative rail or line code violation	0	
—	—	33	RPOS3/ RNRZ3	Ch3 receive Positive rail or NRZ data	0	
—	—	32	RNEG3/ RLCV3	Ch3 receive Negative rail or line code violation	0	
53	—	—	RCLK	Receive clock Ch1	0	Recovered clock for each channel receiver, intended for strobing the corresponding RDAT into the following framer or logic.
—	67	67	RCLK1			
—	34	53	RCLK2	Receive clock Ch2	0	
—	—	34	RCLK3	Receive clock Ch3	0	
49	—	—	TPOS/ TNRZ	Ch1 transmit Positive rail or NRZ data	I	Synchronized transmit data intended to be strobed in by the corresponding TCLK.
—	63	63	TPOS1/ TNRZ1			
48	—	—	TNEG/ NC	Ch1 transmit Negative rail or no connect data	I	When ENDECDIS = 1, these inputs are expected to be positive and negative AMI data (TPOS and TNEG).
—	64	64	TNEG1/ NC1			
—	38	49	TPOS2/ TNRZ2	Ch2 transmit Positive or NRZ data	I	When ENDECDIS = 0, these inputs are expected to be uncoded NRZ data (TNRZ) and no connects (NC).
—	37	48	TNEG2/ NC2	Ch2 transmit Negative rail or no connect data	I	
—	—	38	TPOS3/ TNRZ3	Ch3 transmit Positive or NRZ data	I	See notes on the ENDECDIS pin in the Control Signals section.
—	—	37	TNEG3/ NC3	Ch3 transmit Negative rail or no connect data	I	

Table 1-1. CX2833i-1x Pin Definitions (3 of 7)

Pin #			Signal Name	Description	I/O/P	Notes	
CX28331-1x	CX28332-1x	CX28333-1x					
50	—	—	TCLK	Transmit clock Ch1	I	Transmit bit clock input for strobing with transmit data into the CX2833i.	
—	62	62	TCLK1				
—	39	50	TCLK2				Transmit clock Ch2
—	—	39	TCLK3				Transmit clock Ch3
52	—	—	RLOS	Loss of signal Ch1	0	Loss Of Signal (LOS) indication for each channel, as determined by insufficient pulse density. Signal loss detected when RLOS = 1. Loss of Signal is asserted and deasserted under conditions discussed in section 2.3.5	
—	66	66	RLOS1				
—	35	52	RLOS2				Loss of signal Ch2
—	—	35	RLOS3	Loss of signal Ch3	0		
Control Signals							
59	59	59	ENDECDIS	Encoder/decoder disable (for all channels)	I	1 = Dual rail pulse coded data format. Input transmit data pins TPOS, TNRZ, TNEG and NC are interpreted as TPOS and TNEG (encoded positive and negative rail data). Output receive data pins RPOS and RNRZ, and RNEG and RLCV are interpreted as RPOS and RNEG, with RPOS having a positive pulse in place of every positive AMI pulse and RNEG having a negative pulse in place of every negative AMI pulse. 0 = NRZ format. Transmit data pins TPOS and TNEG are interpreted as TNRZ and NC (not connected). Receive data pins RPOS and RNEG are interpreted as RNRZ and RLCV. In this mode, all line code violations are reported as active high on RLCV.	
51	—	—	TAIS	Transmit Ch1 AIS mode enable	I	Transmission of Alarm Indication Signal (AIS) for a given channel. Replace transmit data with AIS signal. The AMI form of AIS supported is alternating 1s. (+1, -1, +1, -1, +1, ...) AIS will overwrite data during local loopback. 1 = AIS mode enabled 0 = AIS mode disabled	
—	61	61	TAIS1				
—	40	51	TAIS2				Transmit Ch2 AIS mode enable
—	—	40	TAIS3	Transmit Ch3 AIS mode enable	I		

Table 1-1. CX2833i-1x Pin Definitions (4 of 7)

Pin #			Signal Name	Description	I/O/P	Notes
CX28331-1x	CX28332-1x	CX28333-1x				
43	43	43	E3MODE	E3MODE	I	When the pin is set to high, it enables the E3 mode on all channels, instead of the DS3/STS-1 mode. This also changes the pulse shaper to E3 mode and overrides all LBO pins. It also changes the encoder/decoder from B3ZS mode to HDB3 mode. 1 = E3 mode 0 = DS3/STS-1 mode
44	—	—	LBO	Transmit line Ch1 build-out mode	I	Line build-out mode per channel, based on the length of cable on the transmit side of the cross-connect block. This bit is overridden and the pulse shaper is disabled (no pulse shaping) if E3MODE = 1. 1 = Inserts line build-out into the transmit channel. Usually used when the transmit cable is less than 450 feet in length. 0 = Line build-out bypassed (not inserted). Usually used when the transmit cable is greater than 450 feet in length.
—	72	72	LBO1			
—	29	44	LBO2	Transmit line Ch2 build-out mode	I	
—	—	29	LBO3	Transmit line Ch3 build-out mode	I	
56	—	—	LLOOP	Local loopback enable Ch1	I	
—	74	74	LLOOP1			
—	27	56	LLOOP2	Local loopback enable Ch2	I	
—	—	27	LLOOP3	Local loopback enable Ch3	I	
57	—	—	RLOOP	Remote loopback enable Ch1	I	
—	75	75	RLOOP1			
—	26	57	RLOOP2	Remote loopback enable Ch2	I	
—	—	26	RLOOP3	Remote loopback enable Ch3	I	
45	—	—	XOE	Transmit output enable Ch1	I	Transmit output enable per channel. 1 = transmit line output driver enabled 0 = transmit output driver set to high impedance state
—	71	71	XOE1			
—	30	45	XOE2	Transmit output enable Ch2	I	
—	—	30	XOE3	Transmit output enable Ch3	I	

Table 1-1. CX2833i-1x Pin Definitions (5 of 7)

Pin #			Signal Name	Description	I/O/P	Notes
CX28331-1x	CX28332-1x	CX28333-1x				
46	—	—	REQH	Ch1 Receive High EQ Gain Enable	I	The equalizer in the CX2833i has two gain settings. The higher gain setting is designed to optimally equalize a nominally-shaped (meets the pulse template), pulse-driven DS3 or STS-1 waveform that is driven through 0–900 feet of cable. Square-shaped pulses such as E3 or DS3-HIGH require less high-frequency gain and should use the low EQ gain setting. REQH = 1 high EQ gain (DS3/STS-1 modes) REQH = 0 low EQ gain (E3/DS3 Square Modes)
—	70	70	REQH1			
—	31	46	REQH2	Ch2 Receive High EQ Gain Enable		
—	—	31	REQH3	Ch3 Receive High EQ Gain Enable	I	
Power/Ground						
12	—	—	TVDD	TX power Ch1	P	Power pins for transmit circuitry per channel (3.3 V).
—	4	4	TVDD1			
—	20	12	TVDD2	TX power Ch2	P	
—	—	20	TVDD3	TX power Ch3	P	
9	—	—	TVSS	TX ground Ch1	P	Ground pins for transmit circuitry per channel.
—	1	1	TVSS1			
—	17	9	TVSS2	TX ground Ch2	P	
—	—	17	TVSS3	TX ground Ch3	P	
13	—	—	RVDD	RX power Ch1	P	Power pins for receive circuitry per channel (3.3 V). Connect to 3.3 V power.
—	5	5	RVDD1			
—	21	13	RVDD2	RX power Ch2	P	
—	—	21	RVDD3	RX power Ch3	P	
16	—	—	RVSS	RX ground Ch1	P	Ground pins for receive circuitry per channel. Connect to ground.
—	8	8	RVSS1			
—	24	16	RVSS2	RX ground Ch2	P	
—	—	24	RVSS3	RX ground Ch3	P	
60	60	60	DVDDC	Digital core power	P	Digital core power for all channels (3.3 V).
41	41	41	DVSSC	Digital core ground	P	Digital core ground for all channels.
79	79	79	VGG	5 V/3.3 V ESD pin ⁽¹⁾	P	5 V supply for 5 V-tolerant, digital pad ESD diodes. No static power is drawn from pin.
73	73	73	DVDDIO	Digital I/O power	P	Connect to 3.3 V digital power.
28	28	28	DVSSIO	Digital ground	P	Digital ground.

Table 1-1. CX2833i-1x Pin Definitions (6 of 7)

Pin #			Signal Name	Description	I/O/P	Notes
CX28331-1x	CX28332-1x	CX28333-1x				
4, 5, 20, 21	12, 13	—	VDD	Power	P	Connect to 3.3 V power.
1, 8, 17, 24	9, 16	—	VSS	Ground	P	Connect to ground.
Miscellaneous						
58	—	—	$\overline{\text{PD}}$	Power down for Ch1	I	Power down transceiver channel 0 = Power down channel (off) 1 = Channel active (on) Note: A special power-down mode exists when all three PDBs are set low. This special mode shuts off the entire chip (including biasing). This is useful for static I _{dd} testing.
—	76	76	$\overline{\text{PD1}}$			
—	25	58	$\overline{\text{PD2}}$	Power down for Ch2	I	
—	—	25	$\overline{\text{PD3}}$	Power down for Ch3	I	
47	—	—	REFCLK	Reference clock for Ch1	I	Reference clock from off-chip. This clock should be set to one of the following with all rates = ± 20 ppm tolerance: <ul style="list-style-type: none"> • E3 rate (34.368 MHz) • DS3 rate (44.736 MHz) • STS-1 rate (51.84 MHz) The clock rate should correspond to the mode of operation that has been chosen for the channel. See Section 2.5.2 , Power-On Reset, about the valid clock available during power-up.
—	65	65	REFCLK1			
—	36	47	REFCLK2	Reference clock for Ch2	I	
—	—	36	REFCLK3	Reference clock for Ch3	I	
80	80	80	RBIAS	Bias resistor	0	A 12.1 k Ω \pm 1% resistor tied from this pin to ground provides the current reference to the entire chip. ⁽²⁾
78	78	78	Reset	Reset	I	Asynchronous reset (reset entire device). Active-high input.
77	77	77	GPD	Global Power Down	I	Power down (Static I _{dd} testing). 0 = Power down disable 1 = Power down active Global Power Down (GPD), when deasserted, places the device in a reset condition. See Section 2.5.2 , Power-On Reset.

Table 1-1. CX2833i-1x Pin Definitions (7 of 7)

Pin #			Signal Name	Description	I/O/P	Notes
CX28331-1x	CX28332-1x	CX28333-1x				
2, 3, 6, 7, 18, 19, 22, 23, 25, 26, 27, 29, 30, 31, 32, 33, 34, 35, 36, 37, 38, 39, 40, 42, 61, 62, 63, 64, 65, 66, 67, 68, 69, 70, 71, 72, 74, 75, 76	10, 11, 14, 15, 42, 44–58	42	NC	No connect	—	Not connected.
<p>NOTE(S):</p> <p>(1) This pin should be connected to 3.3 V in an all-3.3 V design.</p> <p>(2) Placing a capacitor from this pin to ground may result in instabilities.</p> <p>3. All digital input pins contain a 75 kΩ pull-down resistor from input to DVSS.</p>						

2.0 Functional Description

2.1 Overview

The CX28333 is a triple E3/DS3/STS-1 Line Interface Unit (LIU). It is the physical layer interface between the data framer (or other terminal-side equipment) and the electrical cable used for data transmission.

The CX28333 LIU consists of three independent data transceivers that can operate over type 734/728 coaxial cable at the rates of 34.368 Mbps (E3), 44.736 Mbps (DS3), and 51.84 Mbps (STS-1). The transmit side takes an NRZ or already-encoded dual rail input and encodes it into AMI B3ZS (for DS3/STS-1) or HDB3 (for E3) analog waveforms to be transmitted over 75 Ω coaxial cable. The receiver side takes in the attenuated and distorted analog receive signal and equalizes, slices, and resynchronizes the signal before decoding it to the NRZ output or sending out a non-decoded dual rail.

CX28331 and CX28332 are single- and dual-E3/DS3/STS-1 LIUs, respectively. In all respects, their performance and features are identical to the CX28333.

The architecture of the CX28333i includes the following internal functions for each channel:

Transmitter:

- AMI B3ZS/HDB3 encoder
- pulse shaper
- line driver
- Alarm Indication Signal (AIS) insertion

Receiver:

- receive sensitivity
- Automatic Gain Control (AGC)
- receive equalizer
- Clock Recovery circuit
- Loss Of Signal (LOS) detector
- B3ZS/HDB3 decoder with bipolar violation detector
- data squelching

Additional Functions:

- bias generator
- power-on reset
- loopback MUXes

In addition, each channel has the ability to perform remote and local loopbacks. Figure 2-1. illustrates a typical application using the CX2833i in a channel.

External pins are provided to configure the various line rates and formats for each channel.

The CX2833i is used as a data transceiver over a coaxial cable that is up to 900 feet long (or up to 450 feet from the DSX) in an on-premise environment within any public or private networks which use these data rates.

Figure 2-1. Typical Application Of Single CX2833i Channel

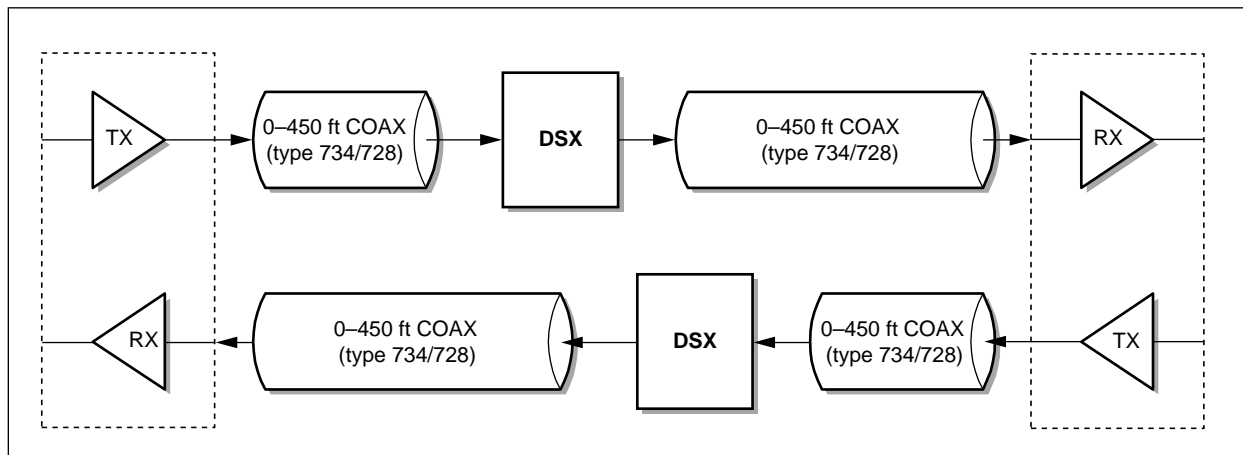

2.2 Transmitter

This section describes the detailed operation of the various blocks in the CX2833i transmitter.

2.2.1 AMI B3ZS/HDB3 Encoder

The ENDECDIS and E3MODE pins configure the encoder mode.

When ENDECDIS = 0, the encoder is receiving non-encoded Nonreturn to Zero (NRZ) data on the TNRZ (TPOS) pin alone, and the NC (no connect) (TNEG) pin is ignored.

Data is encoded into a representation of a three-level B3ZS (E3MODE = 0) or HDB3 (E3MODE = 1) signal before going on to the pulse shaper in the form of two binary signals representing the positive and negative three-level pulses.

When ENDECDIS = 1, the encoder is disabled. The encoder passes already-encoded data over TPOS (TNRZ) and TNEG (NC) to the pulse shaper.

The transmit digital data is clocked into the chip via a rising TCLK edge, which must be equal to the symbol rate (line rate). A small delay added to the data provides a certain amount of negative data hold time.

2.2.2 Pulse Shaper

The pulse shaper converts the two digital (clocked) positive and negative pulses into a single analog three-level Alternate Mark Inversion (AMI) pulse. The pulses are in Return to Zero (RZ) format, meaning that all positive and negative pulses have a duration of the first half of the symbol period.

For the E3 rate (E3MODE = 1), the AMI pulse is a full-amplitude, square-shaped pulse with very little slope.

Figure 2-2. Pulse Shaper

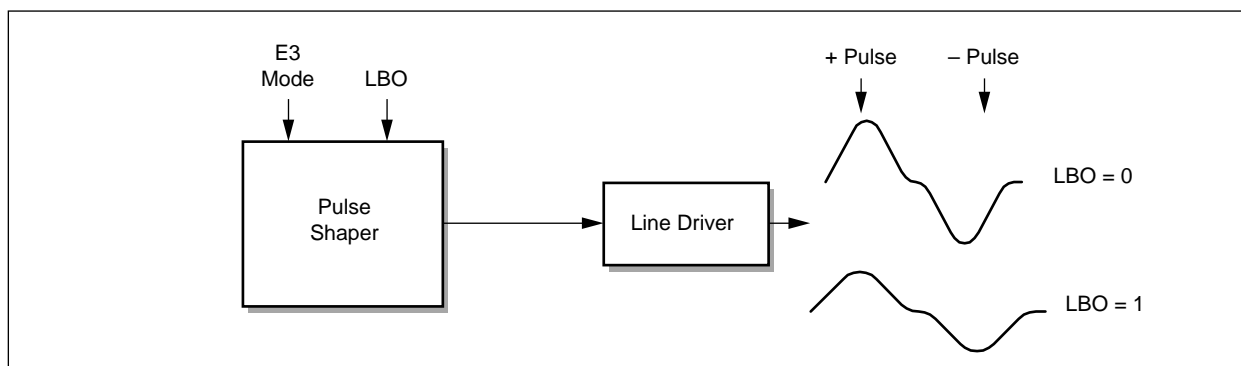

500020_010

For DS3/STS-1 rates, a pulse-shaper block is used to shape the transmit waveform and reduce its high-frequency energy content. This ensures that the transmit pulse template is met at the cross-connect block, which follows 0–450 feet of transmit-side coaxial cable.

2.2.3 Line Driver

The differential line driver takes the filtered transmit waveform, increases it to the proper level, and drives it into the transmit magnetics. The two external discrete back-matching resistors (31.6Ω) aid in line matching. The driver is presented with an approximately 150Ω differential load. Driver gain accounts for the 6 dB gain loss in the back-matching resistors.

Figure 2-3. illustrates the Pulse/Power template measurement points for the various data rates.

Figure 2-3. Pulse Measurement Points

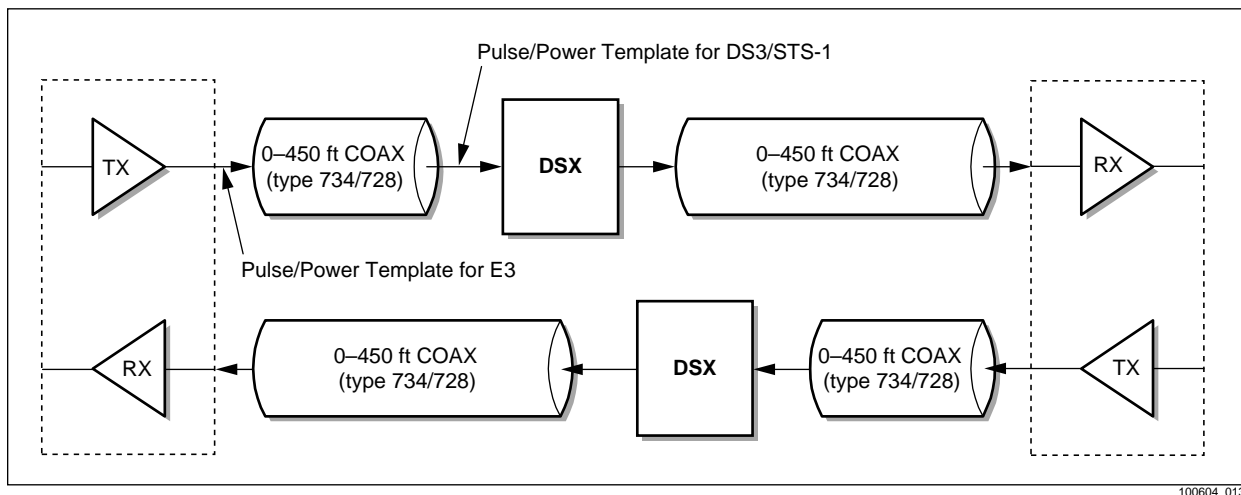

2.2.3.1 Transmit Pulse Mask Templates

The Transmit Pulse Mask characteristics of the CX2833i device are designed so that the transmitted output meets the Pulse Shape mask specified in *ITU-T Recommendation G.703*.

Figure 2-4. Transmit Pulse Mask for DS3 Rates

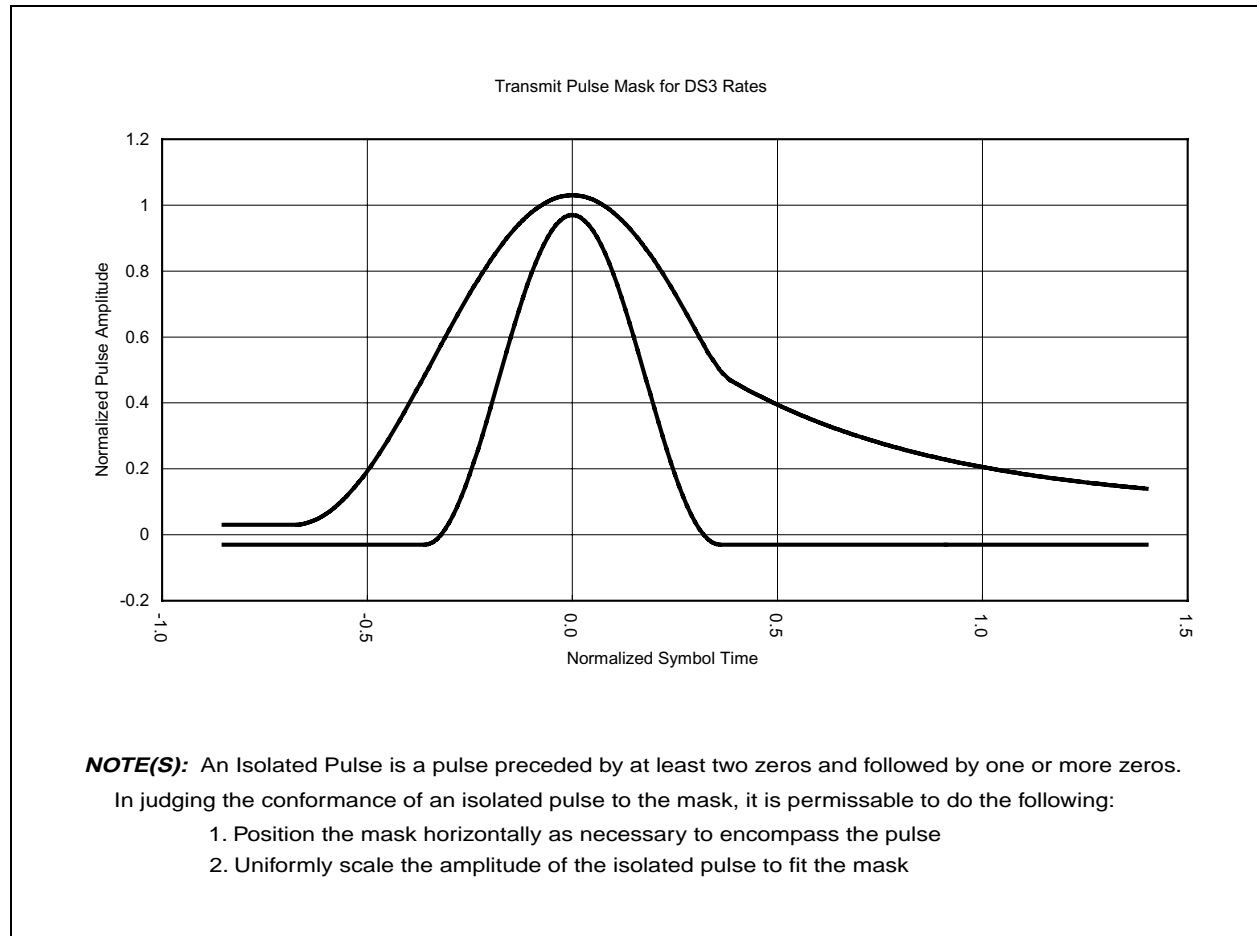
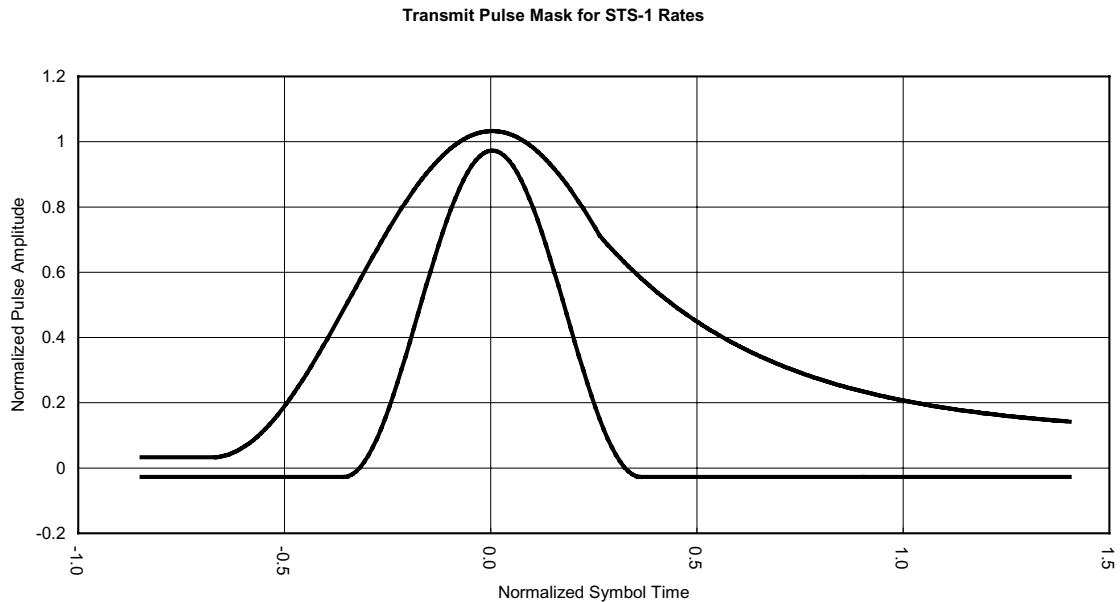

Table 2-1. DS3 Transmit Template Specifications

Time Axis Range (UI) ⁽¹⁾	Normalized Amplitude Equation
Upper Curve	
$-0.85 \leq T \leq -0.68$	0.03
$-0.68 \leq T \leq 0.36$	$0.03 + 0.5 \{1 + \sin [(\pi / 2)(1 + T / 0.34)]\}$
$0.36 \leq T \leq 1.4$	$0.08 + 0.407 e^{-1.84(T - 0.36)}$
Lower Curve	
$-0.85 \leq T \leq -0.36$	-0.03
$-0.36 \leq T \leq 0.36$	$-0.03 + 0.5 \{1 + \sin [(\pi / 2)(1 + T / 0.18)]\}$
$0.36 \leq T \leq 1.4$	-0.03
NOTE(S):	
⁽¹⁾ UI = 1 / (System Clock Frequency)	

Figure 2-5. Transmit Pulse Mask for STS-1 Rates



NOTE(S): An Isolated Pulse is a pulse preceded by at least two zeros and followed by one or more zeros.

In judging the conformance of an isolated pulse to the mask, it is permissible to do the following:

1. Position the mask horizontally as necessary to encompass the pulse
2. Uniformly scale the amplitude of the isolated pulse to fit the mask

Table 2-2. STS-1 Transmit Template Specifications

Time Axis Range (UI) ⁽¹⁾	Normalized Amplitude Equation
Upper Curve	
$-0.85 \leq T \leq -0.68$	0.03
$-0.68 \leq T \leq 0.26$	$0.03 + 0.5 \{1 + \sin[(\pi / 2)(1 + T / 0.34)]\}$
$0.26 \leq T \leq 1.4$	$0.1 + 0.61 e^{-2.4(T - 0.26)}$
Lower Curve	
$-0.85 \leq T \leq -0.36$	-0.03
$-0.36 \leq T \leq 0.36$	$-0.03 + 0.5 \{1 + \sin[(\pi / 2)(1 + T / 0.18)]\}$
$0.36 \leq T \leq 1.4$	-0.03
NOTE(S):	
⁽¹⁾ UI = 1 / (System Clock Frequency)	

Figure 2-6. Transmit Pulse Mask for E3 Rate

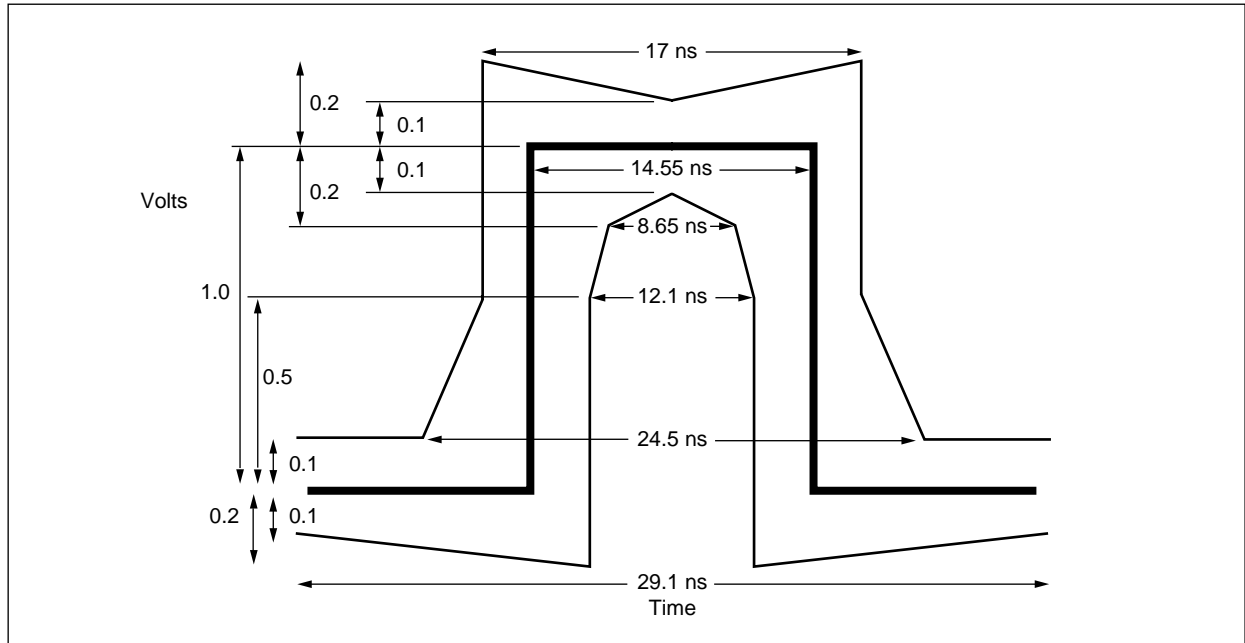

500118a_1

2.2.4 Alarm Indication Signal (AIS) Generator

When TAIS is asserted, an AIS replaces the transmit data at TPOS and TNEG. The E3 type of AIS signal (all 1s) is supported. In three-level signal form, this is a continuously alternating positive and negative pulse stream, as if the transmit data were a continuous string of logical 1s. [Figure 2-7](#) illustrates the AIS signal.

The TAIS pin has the same data latency as the TX data pins and can be used to replace single symbols within a data stream. When the encoder is disabled (ENDECDIS = 1), the TAIS mode maintains the proper phase, based upon the polarity of the last 1 received.

The transmit AIS generator overwrites data during local loopback operation, it does not affect remote loopback operation.

Figure 2-7. AIS Signal

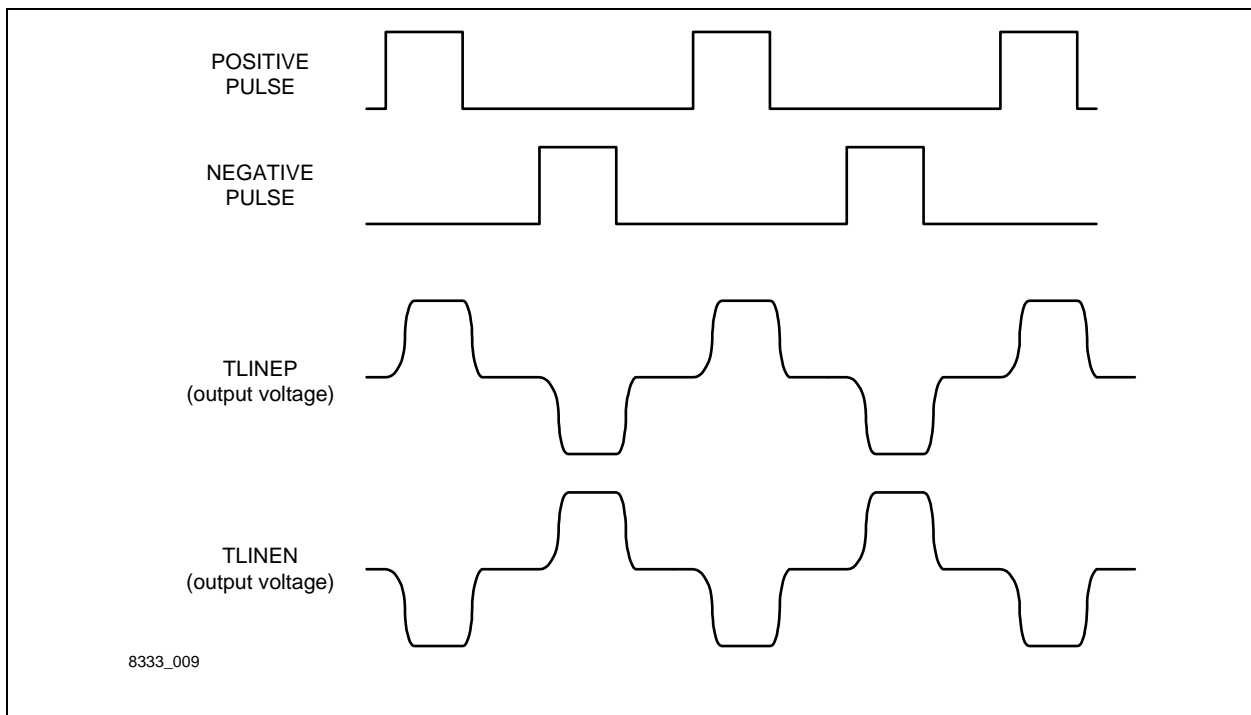

2.2.5 Jitter Generation (Intrinsic)

The CX2833i device meets the jitter generation requirements for various rates with large margins, with the condition that the input transmit clock (TCLK) is jitter-free. Data rates and jitter generation requirements are defined in the following documents:

- E3 rate—*ETSI TBR24, ITU-T G.823 (Section 3.1.2)*
- DS3 rate—*Bellcore GR499, AT&T Accunet TR54014, ITU-T G.824*
- STS-1 rate—*Bellcore GR253*

2.3 Receiver

This section describes the detailed operation of the various blocks in the CX2833i receiver.

2.3.1 Receive Sensitivity

The receiver recovers data from the coaxial cable that is attenuated due to the frequency-dependent characteristics of the cable. In addition, the receiver compensates for the flat loss (across all frequencies) in the various electrical components and the variation in transmitted signal power.

The CX2833i device is able to recover data that has been attenuated by a maximum of 900 feet of coax having characteristics and attenuation consistent with *ANSI T1.102-1993*, Annex C, Figure C.2. This approximates the characteristics of AT&T type 734/728 cable; almost the same attenuation characteristic is achieved by one-half the length of AT&T type 735 cable.

2.3.2 AGC/VGA Block

The Variable Gain Amplifier (VGA) receives the AMI input signal from the coaxial cable. The VGA supplies flat gain (independent of frequency) to make up for various flat losses in the transmission channel and for loss at one-half the symbol rate that cannot be made up by the equalizer. The VGA gain is controlled by a feedback loop which senses the amplitude of the equalizer output, acting to servo this amplitude for optimal slicing.

2.3.3 Receive Equalizer

The receive equalizer receives the differential signal from a VGA and boosts the high frequency content of the signal to reduce intersymbol interference (ISI) to the point that correct decisions can be made by the slicer with a minimum of jitter in the recovered data.

The REQH pin when set high (REQH = 1) boosts the amount of equalization in the receive side of the LIU. DS3/STS-1 pulses require a greater amount of equalization than standard E3 pulses. REQH is therefore normally set high (REQH = 1) for standard DS3/STS-1 pulses.

For cases where a square-shaped DS3/STS-1 pulse (that does not meet the DS3/STS-1 standards) is transmitted to the receiver REQH can be set low (REQH = 0).

In E3 mode, the REQH pin should always be set low (REQH = 0) to prevent over-equalization.

2.3.4 The PLL Clock Recovery Circuit

The clock recovery circuit (RX PLL) extracts the embedded clock from the sliced data and provides this clock and the retimed data to the decoder (data mode). Upon startup (after the internal reset is deasserted), the RX PLL uses a reference clock (REFCLK) and a phase-frequency detector to lock to the correct data rate (reference mode). During reference mode, the data outputs are squelched (set to 0). The RX PLL is kept in reference mode until a valid input is detected.

2.3.5 Loss Of Signal (LOS) Detector

The RLOS detector circuitry consists of two functional blocks: the analog section and the digital. The analog section consists of high-speed, low-offset comparators used for amplitude qualification. The digital block qualifies the pulse stream 1s density and zero run length.

Table 2-3. RLOS Threshold Settings

Action	Min (mV)	Typical (mV)	Max (mV)
RLOS Cleared	—	55	125
RLOS Declared	18	20	—

The digital block asserts RLOS when no valid pulses (per the analog section described above) have been received for 128 REFCLKs. The digital block clears the RLOS when the valid pulse density exceeds 20.3% with less than 64 consecutive zeros during an 128-symbol period.

2.3.6 B3ZS/HDB3 Decoder With Bipolar Violation Detector

In the CX2833i device, when ENDECDIS = 0 (encoder/decoder enabled), the decoder takes the output from the clock recovery circuit and decodes the data (HDB3 or B3ZS) into a single retimed NRZ data signal. The data signal is then sent out of the CX2833i over the RNRZ (RPOS) pin. Any detected Line Code Violations (LCV) are sent out over the corresponding RLCV (RNEG) pin. The RLCV pin is asserted for one symbol period at the time the violation appears on the RX output pin (RNRZ).

The following shows data sequence criteria for LCV; violations are indicated in bold text. A valid bipolar pulse is indicated by a B. A bipolar violation (non-alternating positive or negative) pulse is indicated by a V.

- Excessive zeros: 0, 0, 0, **0** (HDB3) or 0, 0, **0** (B3ZS). These violations are passed on as 0 data on the RNRZ pin.
- Bipolar violation: B, 0, **V** (i.e., +1, 0, +1 or -1, 0, -1 for HDB3) B, **V** (B3ZS and HDB3). These violations are passed on as 1 data on the RNRZ pin.
- Coding violation: 0, 0, **V** (HDB3) or 0, **V** (B3ZS) with an even number of Bs since the last valid 0 substitution V (follows coding rule). These violations are passed on as 0 data on the RNRZ pin.

The even/odd counter (used to count the number of Bs between Vs) will count a bipolar violation as a B. A coding violation or a valid 0 substitution resets the counter.

When ENDECDIS = 1, the decoder is disabled, and the retimed slicer outputs are sent out over RPOS (RNRZ) and RNEG (RLCV) pins. These outputs are then decoded by the Framer or other downstream device. Line code violations are not detected in this mode of operation. The decoder is configurable for either:

- E3 mode using HDB3 coding (E3MODE = 1)
- DS3/STS-1 mode using B3ZS coding (E3MODE = 0)

The receiver digital data outputs are centered on the rising edge of RCLK (see [Section 2.9](#)).

2.3.7 Data Squelching

A counter in the receiver keeps track of the number of consecutive symbol periods without a valid data pulse. When 128 or more 0s in a row are counted, the receiver assumes that it has lost the signal and resets itself to try and regain the signal. While the receiver is reacquiring the signal, the clock recovery block locks to the reference clock and the data squelching is achieved by forcing the data bits to zero. The data squelching is true in both NRZ and dual rail mode. When the input signal has been properly amplified and equalized, the clock recovery PLL will then switch to the incoming data.

2.4 Jitter Tolerance

The CX2833i receiver is able to tolerate a specified amount of high-frequency jitter in the received signal while providing error-free operation (generally defined as a bit error rate of less than 10^{-9}). The specifications (illustrated in [Figure 2-9](#).) for jitter tolerance are discussed in the following documents:

- E3 rate – *ITU-T G.823* and *ETSI TBR24* contain frequency masks for input jitter tolerance.

NOTE: To meet jitter transfer requirements for loop-timed operation, an external jitter attenuator is required. The jitter attenuator lessens jitter from the receive clock.

- DS3 rate – *Bellcore GR499* specifies jitter tolerance frequency masks for Category I and Category II interfaces.
- STS-1 rate – *Bellcore GR253* specifies a jitter tolerance. It is noted that the STS-1 jitter tolerance differs from DS3 requirements only for Category II interfaces.

Figure 2-8. Minimum Jitter Tolerance Requirement

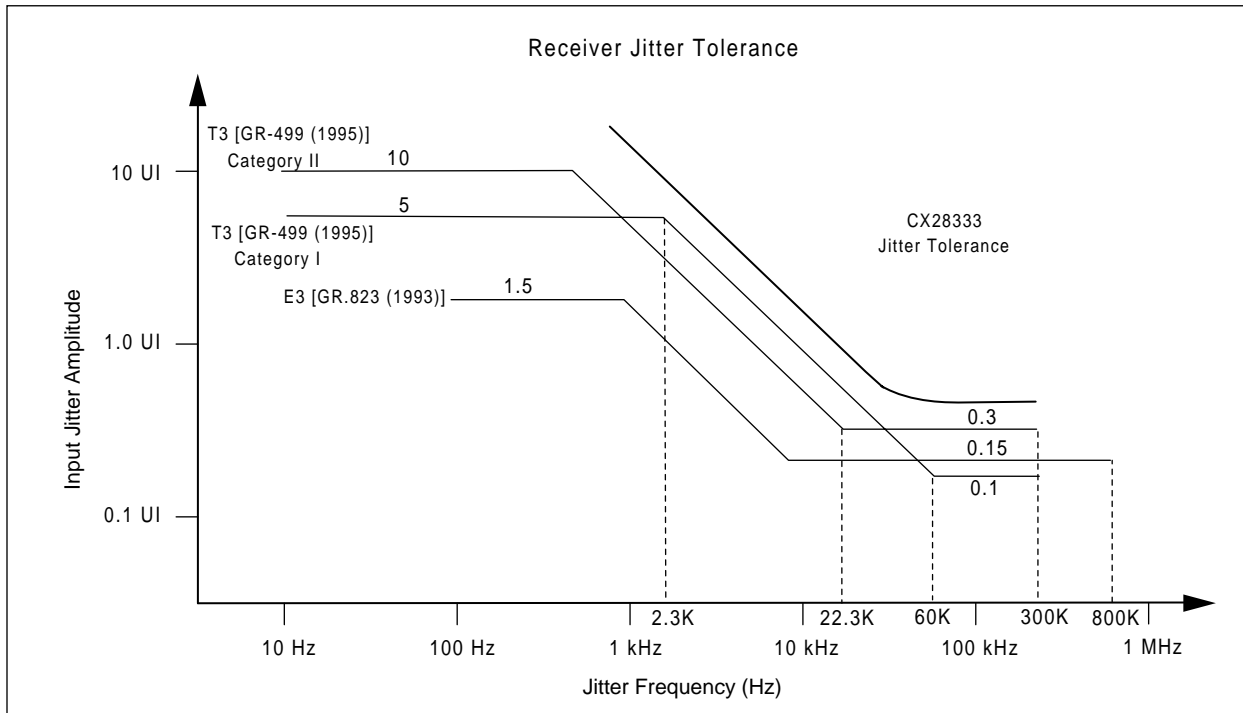

100604_014

2.4.1 Jitter Transfer

The receiver must meet certain jitter transfer specifications between the input and output jitter as a function of frequency. These specifications are only intended to be met with the use of a jitter attenuator. Because the CX2833i does not contain a jitter attenuator, one will have to be supplied externally. For reference purposes, the specifications are discussed in the following documents and shown in [Figure 2-9](#).

E3 rate—Assume the same as DS3.

DS3 rate—Bellcore *GR499*, section 7.3.2 and Figures 7-3, 7-4, and 7-5, defines and describes DS3 jitter transfer.

STS-1 rate—Bellcore *GR253*, section 5.6.2.1, defines and describes jitter transfer for the STS-1 rate.

Figure 2-9. Maximum Jitter Transfer Curve Requirement

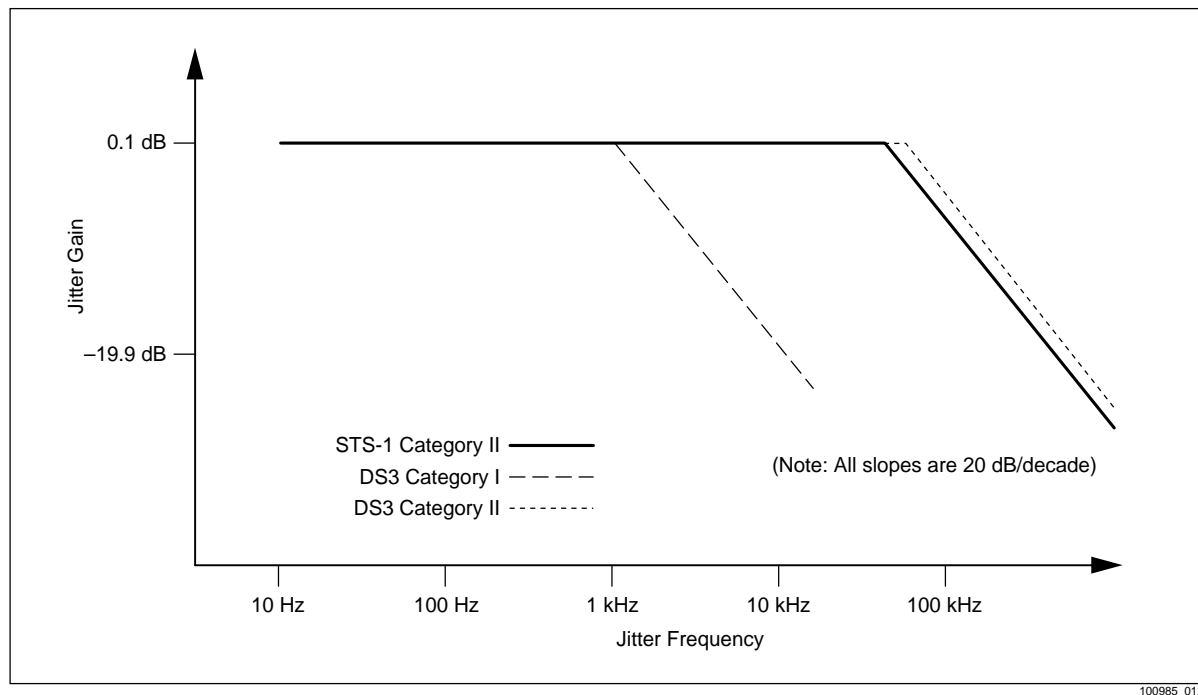

2.5 Additional CX2833i Functions

2.5.1 Bias Generator

To achieve good isolation between the channels, each channel utilizes an independent power and ground to both transmit and receive. Additionally, each channel has its own band gap voltage reference. Because only one external resistor for current generation exists, only one band gap voltage can be used. The band gap from Ch1 has been chosen for this task.

The 12.1 k Ω external resistor from pin RBIAS to ground, is specified to have a tolerance of $\pm 1\%$. This helps to keep tighter control on power dissipation and circuit performance.

NOTE: Capacitance should be kept to a minimum on the RBIAS pin.

2.5.2 Power-On Reset (POR)

If the system cannot guarantee a valid REFCLK frequency input during the POR cycle, the CX2833i devices require assertion (active-high input pulse width, 1 μ s minimum) of the external reset signal (RESET, Pin 78 [80-pin package], Pin 97 [100-pin package]). Valid operation frequencies are DS3 (44.768 MHz ± 20 ppm), E3 (34.368 MHz ± 20 ppm), and STS-1 (51.84 MHz ± 20 ppm). Please refer to the *CX28331/2/3 Evaluation Module User Guide* for crystal oscillator specifications and vendor listings.

A POR circuit is provided in the CX2833i device to initialize all resettable digital logic and analog control lines. The POR circuit uses a fixed RC timer ($\sim 1 \mu$ s) to deassert itself when the power supply voltage reaches a minimum level (~ 2 V). When the minimum supply voltage is reached (see [Table 2-6](#)), the REFCLK input is counted for 128 clocks before the internal reset is deasserted. At this time, the receiver block attempts to frequency lock ($\pm 5\%$ tolerance) onto a valid incoming REFCLK input. After frequency lock is achieved, the receiver attempts to phase lock onto the valid RLINE receive signal.

NOTE: If a valid REFCLK input is not present when POR releases the internal reset, the receiver block may be unable to lock to the RLINE receive signal. It is common for some crystal oscillator types oscillate at a lower fundamental frequency if the crystal oscillator supply has not reached its minimum operation voltage.

2.5.3 Loopback Multiplexers (MUXes)

Two loopback MUXes per channel in the CX2833i allow for local loopback (terminal or framer side), remote loopback (cable side), or both. The RLOS signal monitors the RX cable inputs irrespective of any loopback.

In remote loopback, set by asserting pin RLOOP high, the receive data (retimed after clock recovery but not decoded) loops back into the pulse shaper in place of the transmit data. Additionally, this data is sent out the RPOS, RNEG, and RCLK pins.

In local loopback, set by asserting pin LLOOP, the transmit data loops back immediately from the encoder output to the decoder input in place of the received data. Additionally, this data is sent out the TLINEP and TLINEM/N pins.

Figures 2-10 and 2-11 illustrate remote and local loopback flow.

NOTE: Transmit AIS operation overwrites data with an all 1's pattern during local loopback, it does not affect remote loopback operation.

Figure 2-10. Remote Loopback Diagram

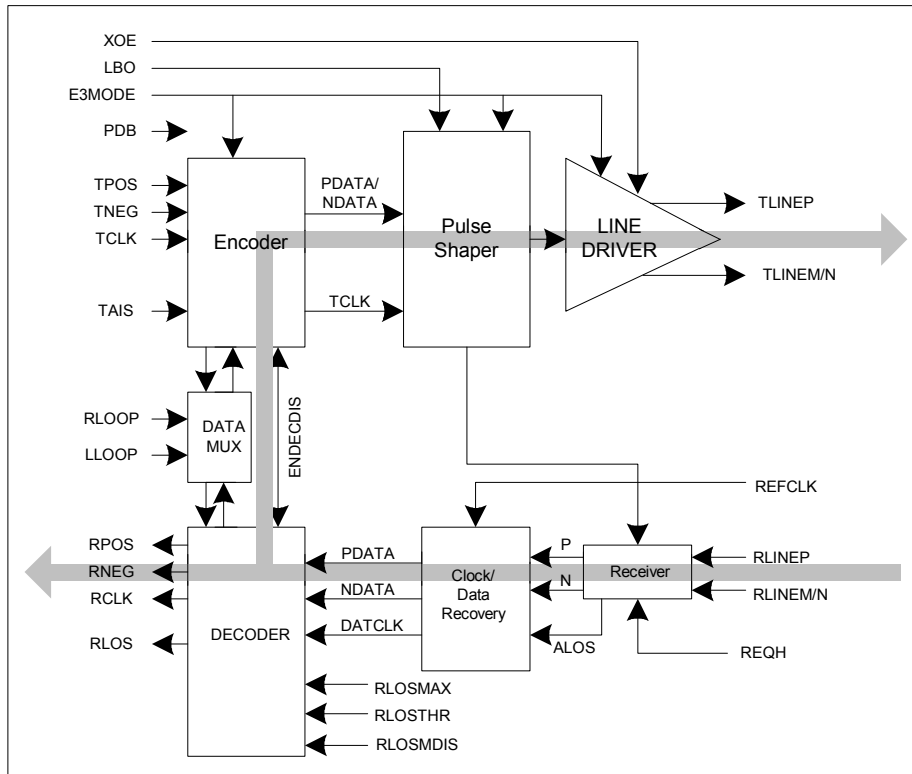
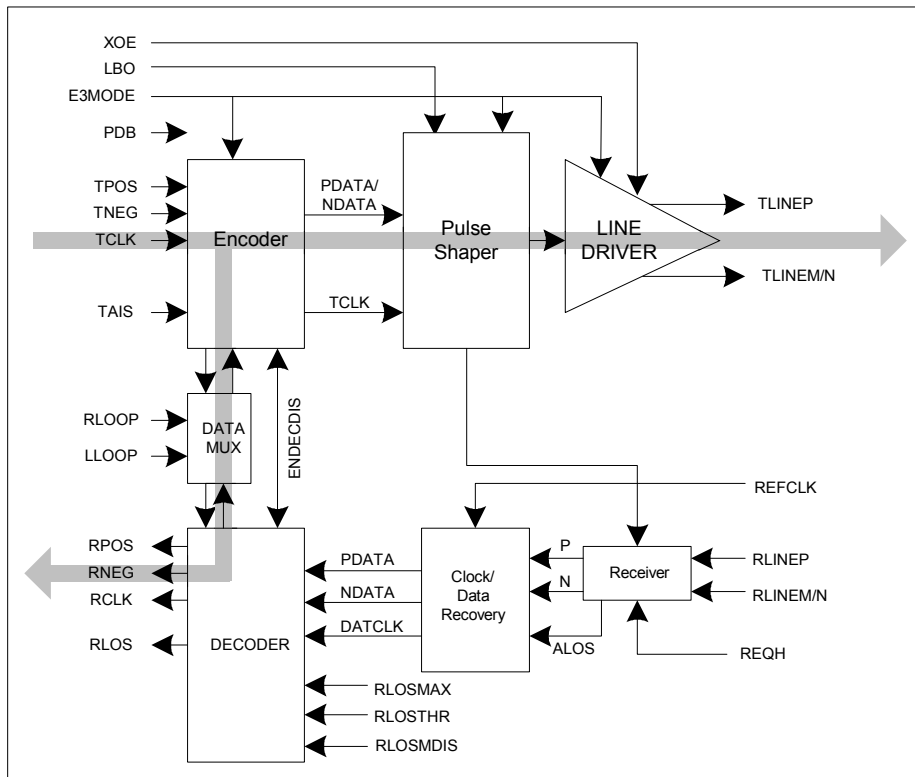
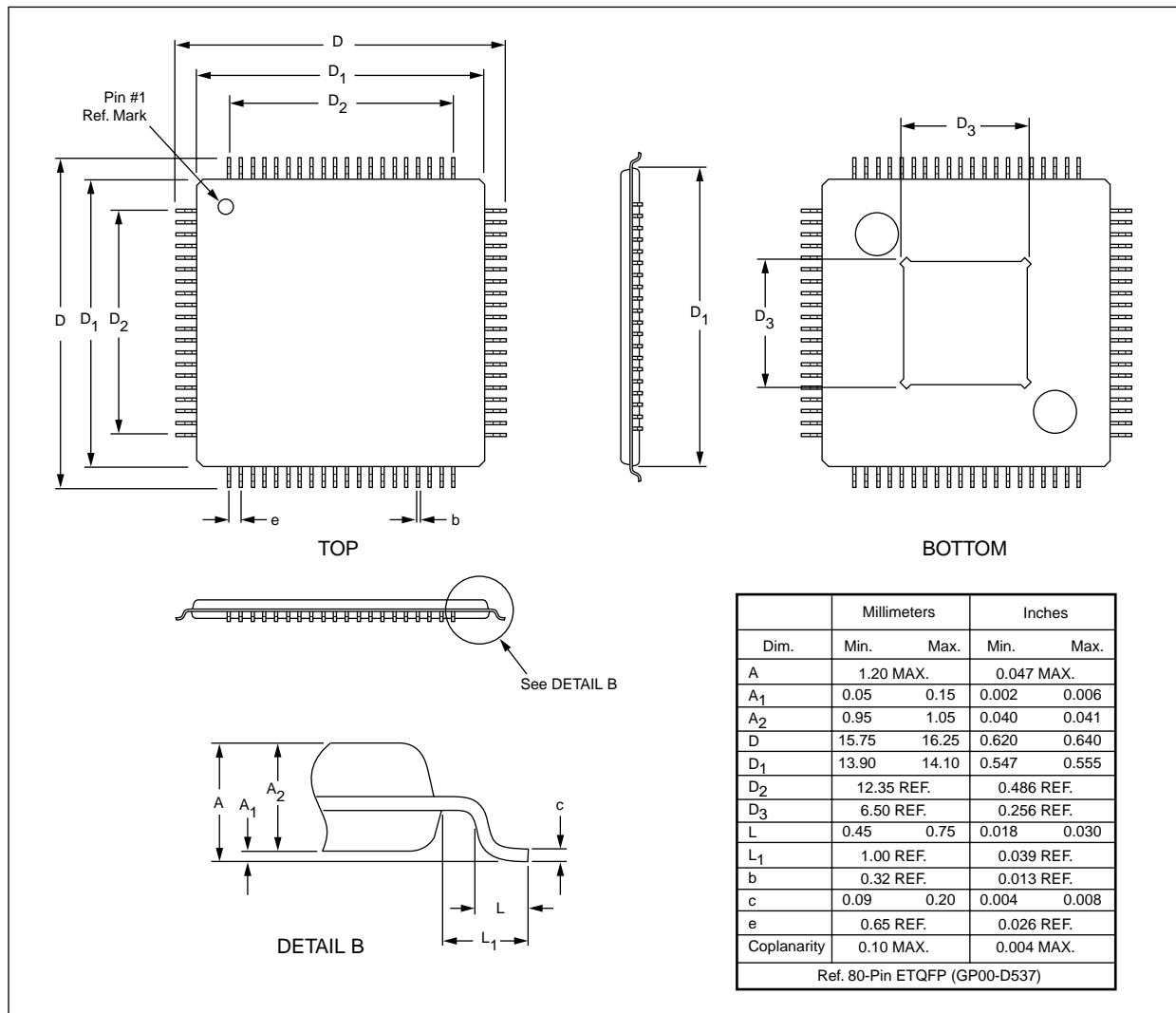

Figure 2-11. Local Loopback Diagram



2.6 Mechanical Specifications

Figure 2-12. CX28331-1x Mechanical Drawing (80-Pin)—Dimensions



100985_008

2.7 Electrical Characteristics

2.7.1 Absolute Maximum Ratings

Table 2-4. Absolute Maximum Ratings

Symbol	Parameter	Min	Max	Unit
DVDDC/ RVDD/ TVDD/ VDD/ VGG	Power Supply Voltage	-0.3	6	V
V_I	Voltage on Any Signal Pin	-1.0	VGG + 0.3 V	V
T_{ST}	Storage Temperature	-40	125	°C
T_{VSOL}	Vapor Phase Soldering Temperature (1 min.)	—	220	°C
θ_{JA}	Thermal Resistance (Still air, socketed)	—	40	°C/W
θ_{JA}	Thermal Resistance (Still air, soldered)	—	24	°C/W
θ_{Jc}	—	—	7.40	°C/W
FIT	Failures in time @ 89,000 device hours, temperature of 55 °C, 0 failures.	—	313	fits
<p>NOTE(S):</p> <p>1. Stresses above those listed as absolute maximum ratings may cause permanent damage to the device. This is a stress rating only, and functional operation of the device at these or any other conditions beyond those indicated in the other sections of this document is not implied. Exposure to absolute maximum rating conditions for extended periods may affect device reliability.</p>				

2.7.2 ESD Ratings

Testing Method—The devices were subjected to ESD events at the rated voltage with both positive and negative polarities relative to each other pin or supply domain on the device. The given pin was then curve-traced to detect leaky or shorted ESD diodes. The criterion for passing is 3 devices that withstand voltage without any leaky pins or functional failures.

Table 2-5. ESD Ratings

Model	Required Minimum	Observed
Human Body	1,000 V	2,000 V
Machine	100 V	200 V
Charged Device	400 V	700 V

2.7.3 Recommended Operating Conditions

Table 2-6 specifies various operating conditions, power supplies, and the bias resistor.

Table 2-6. Recommended Operating Conditions

Parameter	Conditions	Min	Nom	Max	Unit
Power supply voltage (±5%)	DVDDC, RVDD, TVDD, VDD	3.135	3.3	3.465	V
ESD voltage ^(1, 2)	VGG	3.135	5	5.5	V
External bias resistor	Pin RBIAS to GND; ±1%	11.98	12.1	12.22	kΩ
<p>NOTE(S):</p> <p>(1) With 5 V logic input, VGG should be tied to 5 V. With 3.3 V logic input, VGG should be tied to 3.3 V. VGG must be equal or greater than power supply voltage.</p> <p>(2) When VGG is operated at 5V, sequence VGG to DVDDC, RVDD, TVDD, and VDD as discussed in Appendix C.</p>					

2.8 DC Characteristics

Table 2-7. DC Characteristics

Parameter	Conditions	Min	Nom	Max	Unit
V_{ih} high threshold	Digital inputs (Logic 1)	2.0	—	VGG + 0.3	V
V_{il} low threshold	Digital inputs (Logic 0)	-0.3	—	0.8	V
V_{oh} high threshold	Digital outputs, $I_{oh} = -4$ mA	2.4	—	—	V
V_{ol} low threshold	Digital outputs, $I_{ol} = 4$ mA	—	—	0.4	V
I_{LEAK} (digital inputs and outputs)	0 V ≤ digital V_{in} ≤ VGG	-10	—	200	μA
I_{LEAK} (analog inputs and outputs: RLINExP, RLINExM, TLINExP, TLINExM)	—	-270	—	270	μA
Input capacitance	—	—	—	10	pF
Load capacitance	Digital outputs	—	—	15	pF
R_{Line}/T_{Line} capacitance	Maximum load	—	—	50	pF
Power Dissipation					
Power dissipation CX28333 (-1x)	Total chip ⁽³⁾	—	0.83	1.0	W
Power dissipation (CX28332)	Total chip	—	—	0.8	W
Power dissipation (CX28331)	Total chip	—	—	.450	W
NOTE(S):					
1. The digital inputs of CX2833i are TTL 5 V compliant when VGG = 5V. These inputs are diode protected to the VGG pin. Additionally, all of the CX2833i digital inputs contain 75 kΩ pull-down resistors.					
2. The digital outputs of CX2833i are also TTL 5 V compliant when VGG = 5V. However, these outputs do not drive to 5 V, nor do they accept 5 V external pull-ups.					
3. Measured while transmitting and receiving all-1s pattern.					

2.9 AC Characteristics

Table 2-8. AC Characteristics (Logic Timing)

Parameter	Conditions	Min	Nom	Max	Unit
Tosym, Tisym RCLK and TCLK	E3 (34.368 MHz) DS-3 (44.736 MHz) STS-1 (51.84 MHz)	—	29.10 22.35 19.29	—	ns ns ns
Clock Duty Cycle	Towidth/Tosym, RCLK	45	—	55	%
	Tiwidth/Tisym, TCLK	40	—	60	%
	Tiwidth/Tisym, REFCLK	40	—	60	%
Todelay	—	—	—	3	ns
Tisetaup	TPOS/TNRZ, TNEG, TAIS	4	—	—	ns
Tihold	TPOS/TNRZ, TNEG, TAIS	0	—	—	ns
<p>NOTE(S):</p> <ol style="list-style-type: none"> 1. The description applies to the DS3, E3, and STS-1 clock rates and other parameters such as pulse width, set-up time, hold time, and duty cycle. 2. The timing diagram, illustrated in Figure 2-13., describes the logical relationship between various clock and data signals, and parameter values. 3. Todelay is measure with a 10–15 pF loading characteristic. 					

Figure 2-13. Timing Diagram

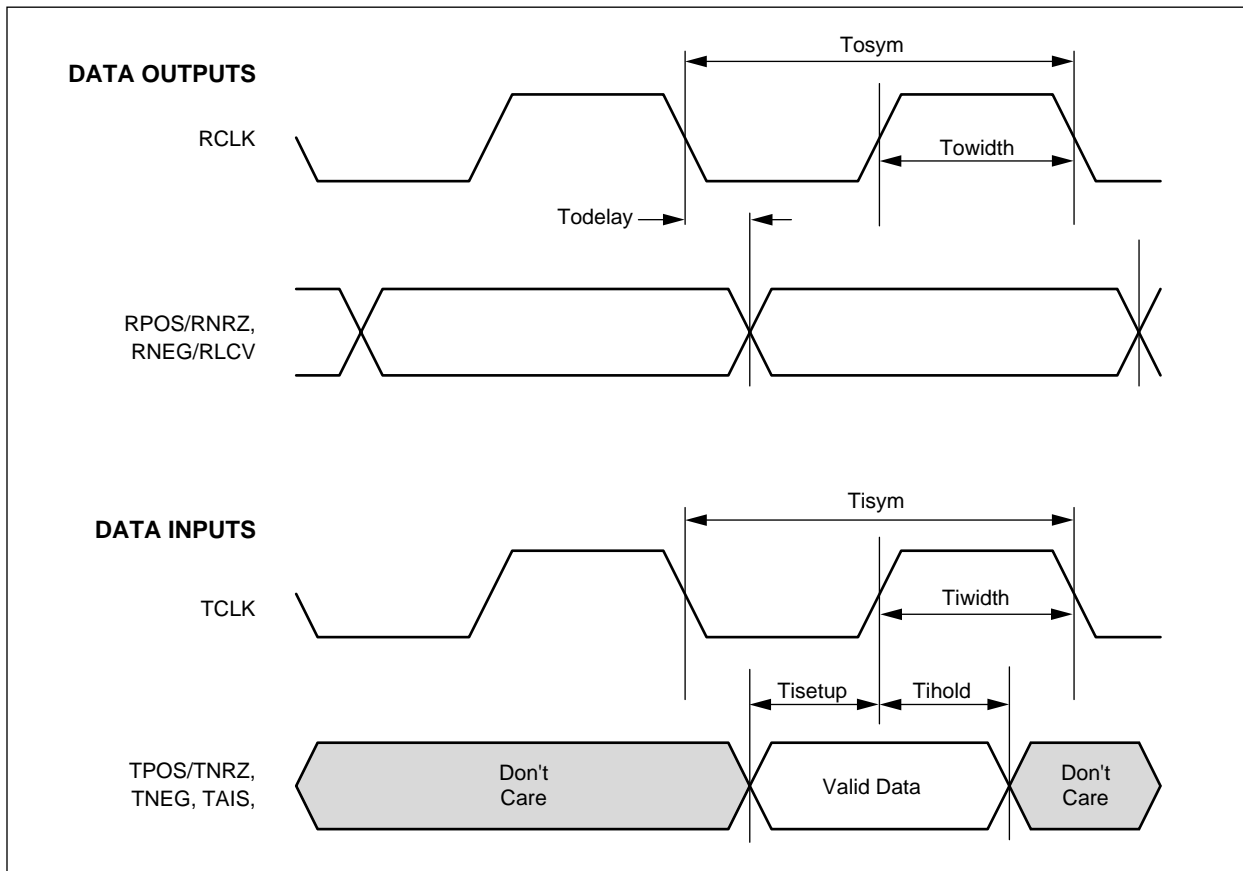

100604_016

3.0 Applications

The CX28331/CX28332/CX28333 can be used in a variety of applications.

Figure 3-1 illustrates an example of three DS3 lines being terminated by the CX28333. The data and clock are extracted and passed on to the framer chip for further data manipulation and user interface.

It is important to employ high-frequency design techniques for the printed board layout.

3.1 PCB Design Considerations for the CX2833i

The CX28333 device is a mixed signal triple-port LIU device operating at frequencies up to 51.84 MHz. This calls for a careful design of the PCB layout.

Some design considerations are outlined below.

3.1.1 Power Supply and Ground Plane

A single power plane with bulk capacitors (typically 10 μf) distributed throughout the board will mitigate most power rail-related voltage transients. A bulk capacitor should also be placed where the power enters the board. It is recommended that decoupling capacitors be routed directly to each of the power pins. It is recommended that 0.1 μf , 0.01 μf , and 0.001 μf decoupling capacitors be used. All three values are not required on each pin, but values should be dispersed uniformly to filter different frequencies of noise. 10 μf tantalum capacitors should be placed on all four corners of the chip.

A continuous ground plane is the best way to minimize ground impedance. Most ground noise is produced by the return currents and power supply transients during switching. This effect is minimized by reducing the ground plane impedance.

3.1.2 Component Placement

- 3.1.2.1 RBIAS Resistor** It is important to keep the RBAIS pins quiet, as any noise coupled to these pins affect the internal references. The RBIAS resistors should be placed as close as possible to the RBAIS pins and no digital signals should be routed near the pins or the resistors. It is recommended to guard the pin, resistor, and traces with ground vias.

3.1.2.2 VGG Decoupling It is recommended that the VGG pin be decoupled with a 0.1 μf , 0.01 μF and 0.001 μf capacitors. These capacitors should be placed close to the VGG pin.

3.1.2.3 Termination Resistors and Capacitors The termination resistors and capacitors on the receive RLINE pins should be placed as close the receiver input on the chip as possible. The series resistors for the transmit TLINE pins should also be placed as close to the transmitter output pins as possible, but are less of a priority then the RLINE.

3.1.3 Impedance Matching

It is critical that both the transmit and receive traces around the transformers and the matching resistors be kept to a minimum length and that the trace impedance be matched to 75 ohms.

The transmit signals between the device and the transformer should be routed 75 ohm differentially. The transmit signals should be routed single ended between the transformer and the BNC connector.

The receive signals should be routed differentially between the transformers and either differentially or single ended from the transformers to the BNC connectors, depending on the application. If the application requires ground termination it is recommended that the signals be routed single ended. If the application does not require ground termination, then the signals can be routed differentially.

To route signals differentially, the signal pair (positive and negative) should be 75 ohm coupled and should be surrounded by solid power/ground planes (buried strip line) or be coupled to a power/ground plane (microstrip). Buried strip line is recommended for internal layers while microstrip line is used for signals routed on surface layers. There should be no discontinuity in the planes during the path of the signal traces.

Single ended signals should be 75 ohm coupled between power/ground planes for inner layers or 75 ohm coupled to a power/ground plane on the outer layers. There should be no discontinuities in the power/ground planes over the trace path.

Impedance discontinuities occur when a signal passes through vias and travels between layers. It is recommended to minimize the number of vias and layers that the transmit/receive signals travel through in the design.

3.1.4 Other Passive Parts

Mindspeed recommends the use of 1:1 transformers for coupling the BNC connectors to the device. The CX28333 uses six Pulse T3001 transformer devices to handle the 3 Tx and 3 Rx channels.

It is recommended that a 220 μF tantalum capacitor be used where the power enters the board.

3.1.5 IBIS Models

IBIS (Input/Output Buffer Interface Specification) models for the CX28331/CX28332/CX28333-1x are available from Mindspeed's web site (www.mindspeed.com).

3.1.6 Recommended Vendors

	Product: Transformers	Product: Crystals
America	Pulse	Crystek Corp.
Address:	Corporate Office 12220 World Trade Drive San Diego, CA 92128	12730 Commonwealth Drive Fort Myers, FL 33913
Telo:	858-674-8100	800-237-3061
Fax:	858-674-8262	941-561-1025
		Telo:
		Fax:
		E-mail:
		Web site:
		www.crystek.com
Northern Asia	Pulse	
	3F-4, No. 81, Sec. 1 Hsin Tai Wu Road Hsi-Chih Tapei Hsien, Taiwan R.O.C.	
Telo:	886-2-26980228 886-2-26980948	
Northern Europe	Pulse	
	1S2 Huxley Road The Surrey Research Park Guildford, Surrey GU2 5RE United Kingdom	
Telo:	44-1483-401700	
Fax:	44-1483-401701	

Figure 3-1. DS3/E3 Application Diagram

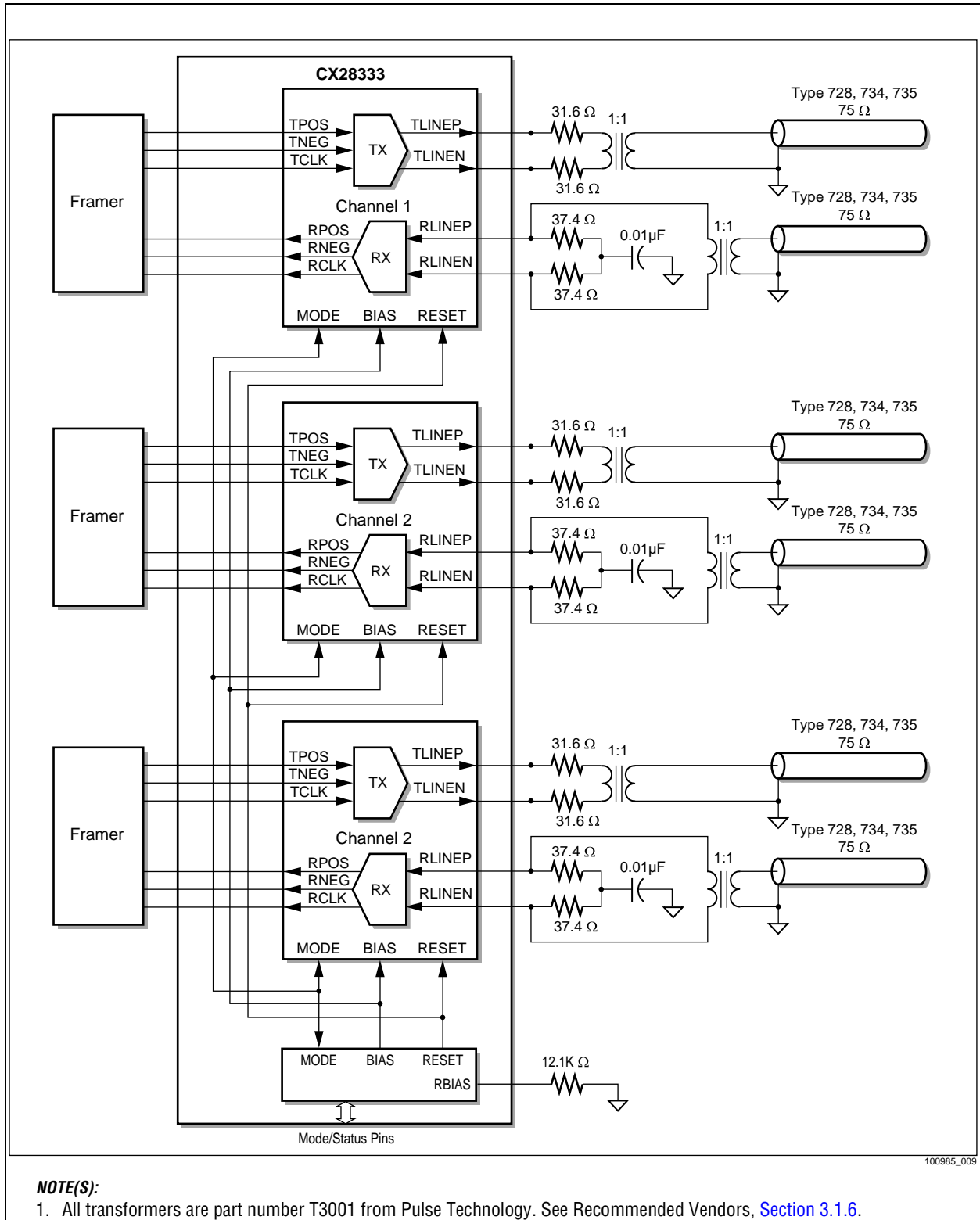

Appendix A: Applicable Standards

The applicable standards documents are as follows:

- *ANSI T1.102-1993* (DS3 and STS-1 standard)
- *ANSI T1.404a-1996* (DS3 metallic interface)
- *ITU Recommendation G.703* (DS3 and E3 standard)
- *ITU Recommendation G.823 and G.824* (jitter and wander)
- *Bellcore GR499*, Issue 1, 12/89 (formerly *TR-TSY-000499*) (DS3 and STS-1 requirements)
- *Bellcore GR253*, Issue 2, 12/91 (formerly *TA-NWT-000253*) (STS-1 Requirements and Jitter)
- *Bellcore TR-TSY-000191*, Issue 1, 5/86 (AIS and LOS)
- *ETSI TBR24 and TBR25* (E3 terminal equipment interface)
- *ETSI ETS 300 686 and ETS 300 687* (E3 standard)
- *AT&T Technical Reference TR54014*, May 1992 (Accunet Interface Specification for DS-3 jitter only)
- *ETSI ETS 300 687*, 1996, “Business Telecommunications; 34 Mbps Digital Leased Lines (D34U and D34S); Connection Characteristics”
- *ETSI ETS 300 686*, 1996, “Business Telecommunication; 34 Mbps and 140 Mbps digital Leased Lines (D34U, D34S, D140U, and D140S); Network Interface presentation”
- *ANSI T1.102-1993*, “Digital Hierarchy—Electrical Interfaces”
- *ANSI T1.107-1995*, “Digital Hierarchy—Formats Specification”
- *ANSI T1.231-1997*, Draft, “Digital Hierarchy—Layer 1 In-Service Digital Transmission Performance Monitoring”
- *ANSI T1.231-1993*, “Digital Hierarchy—Layer 1 In-Service Digital Transmission Performance Monitoring”
- *ANSI T1.404-1994*, “Network-to-Customer Installation—DS3 Metallic Interface Specification”
- *Bellcore GR-499-CORE*, Issue 1, December 1995, “Transport Systems Generic Requirements (TSGR): Common Requirements”
- *Bellcore GR-253-CORE*, Issue 2, December 1995, “SONET Transport Systems: Common Generic Criteria”
- *ITU Recommendation G.703*, 1991, “Physical/Electrical Characteristics of Hierarchical Digital Interfaces”
- *ITU Recommendation G.823*, 1993, “The Control of Jitter and Wander Within Digital Networks Which are Based on the 2,048 kbps Hierarchy”
- *ITU Recommendation O.151*, 1992, “Error Performance Measuring Equipment Operating at the Primary Rate and Above”
- *ETSI TBR 24*, 1997, “Business Telecommunication; 34 Mbps Digital Unstructured and Structured Lease Lines; Attachment Requirements for Terminal Equipment Interface”

Appendix B: Exposed Thin Quad Flat (ETQFP) Pack

NOTE: Mindspeed recommends that the exposed paddle on the CX2833i-1x be soldered to the ground side of the PCB for reasons described below. Do not route PCB traces or vias under the exposed paddle area of the CX2833i-1x device.

The Exposed Thin Quad Flat Pack (ETQFP) package provides greater design flexibility and increased thermal efficiency, while using a standard size IC package. The exposed pad improves performance by permitting higher clock speeds, more compact systems, and a more aggressive design criteria. ETQFP thermal performance is better than standard packages; however, to make optimum use of the thermal efficiencies designed into the ETQFP, the PCB must be designed with this package in mind. The following sections of this document provide more information regarding the thermal performance and PCB design for Mindspeed ETQFPs.

B.1 Introduction

The ETQFP is implemented using a standard epoxy-resin package mold compound. The integrated circuit die is attached to the lead-frame die pad with a thermally conductive epoxy. The leadframe is designed with a deep downset of the die attach pad so it will be exposed on the bottom surface of the package after mold. This provides an extremely low thermal resistance between the IC junction and the exterior of the surface.

The die pad's external surface can be attached to the PCB using standard solder reflow techniques. This allows efficient attachment to the board, and permits the board structure to be used as a heat sink for the IC. Using thermal vias, the lead frame die pad can be attached to a ground plane or special heat sink structure designed into the PCB. [Figure B-1](#) illustrates the schematic of the package components.

Figure B-1. Schematic Representation of the Package Components

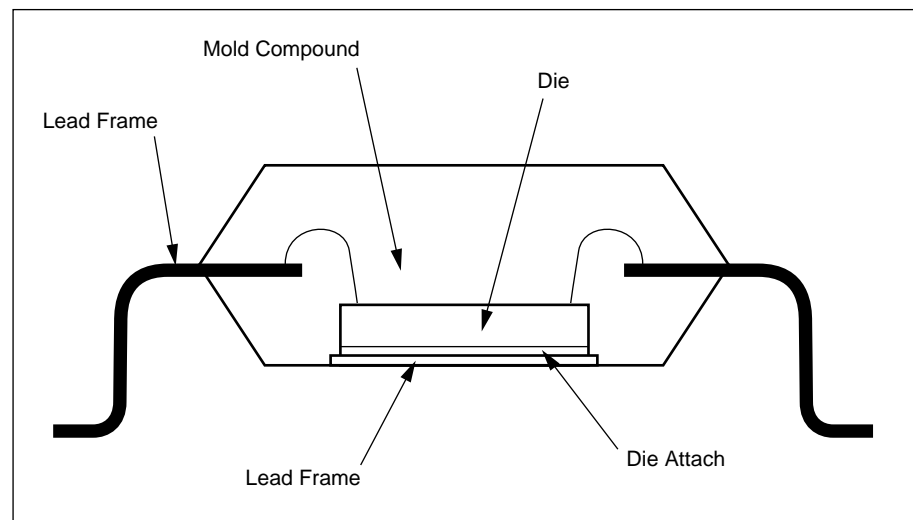

B.2 Package Thermal Characterization

B.2.1 Heat Removal Path

The internal heat removal path is designed to transfer heat from the top surface of the die to the die pad and then directly to the Printed Circuit Board (PCB) through a center solder pad. The PCB must have features designed to remove heat from the package efficiently. At a minimum, there must be an area of solder-tinned copper underneath the ETQFP, called a thermal land. Heat is transferred from the thermal land to the environment through thermal vias designed within the PCB structure.

B.2.2 Thermal Lands

A thermal land is required on the surface of the PCB directly under the body of the exposed package. During normal surface mount reflow, the exposed pad on the underside of the package will be soldered to this thermal land creating an efficient thermal path. The size of the thermal path is as large as needed to dissipate the required heat.

For double-sided PCBs having no internal layers, the surface layers must be used to remove heat. [Figure B-2](#) illustrates a sample package detail, including the required solder mask and thermal land pattern for an EQTFP. The designer may consider external means of heat conduction, such as attaching the copper planes to a convenient chassis member or other hardware convection.

Figure B-2. Package and PCB Land Configuration

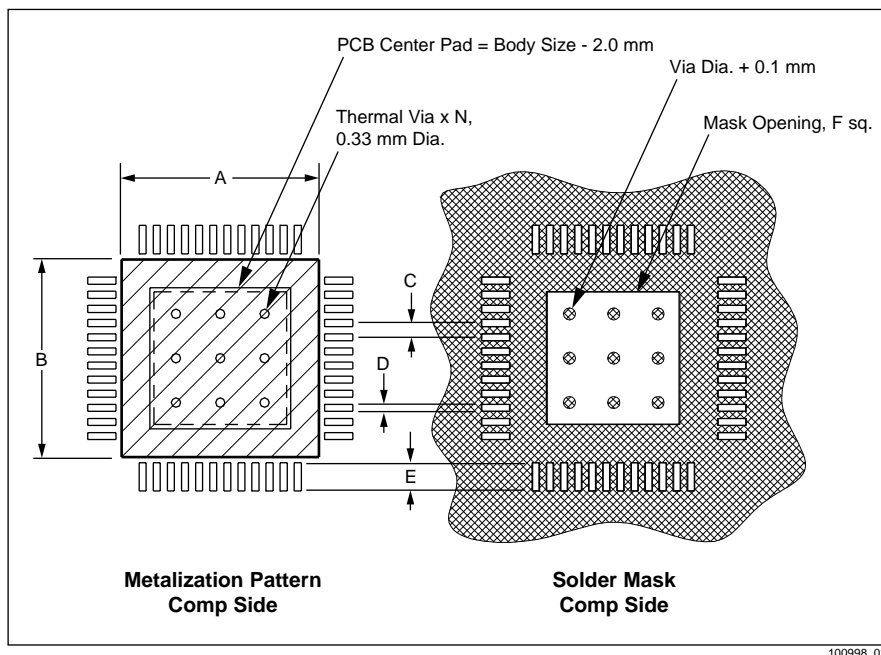

B.2 Package Thermal Characterization*Single/Dual/Triple E3/DS3/STS-1 Line Interface Unit*

An array of 0.33 mm diameter thermal vias plated with 1 oz. copper must be placed on the pad and shorted to the PCB's ground plane. If the plating thickness in the exposed region of the center pad is not sufficient to effectively plug the barrel of the via when plated, use solder mask to cap the vias; the mask diameter should have a dimension equal to the via diameter + 0.1 mm minimum. This prevents the solder from wicking through the thermal via, potentially creating a solder void in the region between the package bottom and the center pad on the surface of the PCB. [Table B-1](#) lists the dimensions for the entire ETQFP package family.

Table B-1. Dimensional Parameters (mm)

Package Type	A	B	C	D	E	F	N ⁽¹⁾
48-lead ETQFP	5.40	5.40	0.50	0.25	1.00	4.70 sq.	3 x 3; 9
80-lead ETQFP	14.40	14.40	0.65	0.35	1.00	6.50 sq.	7 x 7; 49
100-lead ETQFP	14.40	14.40	0.50	0.25	1.00	8.00 sq.	7 x 7; 49

NOTE(S):
⁽¹⁾ N represents the total number of thermal vias to be placed evenly across the entire PCB center pad. In the case of the 48-lead ETQFP, all thermal vias are located within the exposed region of the center pad.

B.2.3 PCB Design

Thermal vias are the primary method of heat transfer from the PCB thermal land to the internal copper planes or to other heat removal sinks. The number, size, and construction of the vias is important in obtaining the best package thermal performance and package/PCB assembly. Thermal performance analysis indicates there is a point of diminishing returns where additional vias will not improve heat transfer through the board.

The PCB internal structure plays a very important role in package thermal performance. Figures B-3 and B-4 illustrate the PCB structure for a two- and six-layer design, respectively. PCB designs with more than two layers should have all thermal vias connected to the ground plane.

Figure B-3. Internal Structure for a Two-Layer PCB

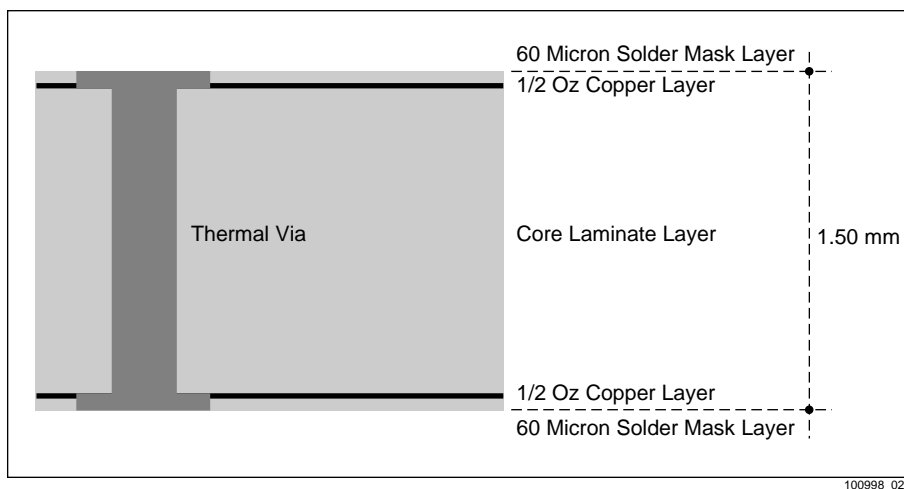
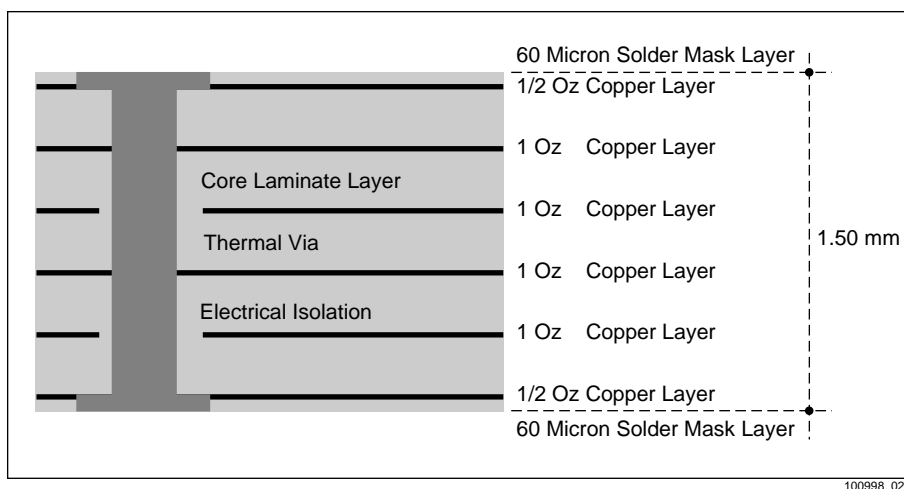

Figure B-4. Internal Structure For a Six-Layer PCB



B.2.4 Thermal Test Structure

B.2.4.1 Test Environment Package thermal performance has been tested following JEDEC standards. The ETQFP package is mounted at the center of a 100 mm × 100 mm, six layer test board and is tested under different air flow velocities. [Figure B-5](#) illustrates the system configuration.

Figure B-5. Test Performance Structure ($A = 100\text{ mm}$, $B = 100\text{ mm}$, $L_P = 1.40\text{ mm}$, $L_B = 1.60\text{ mm}$)

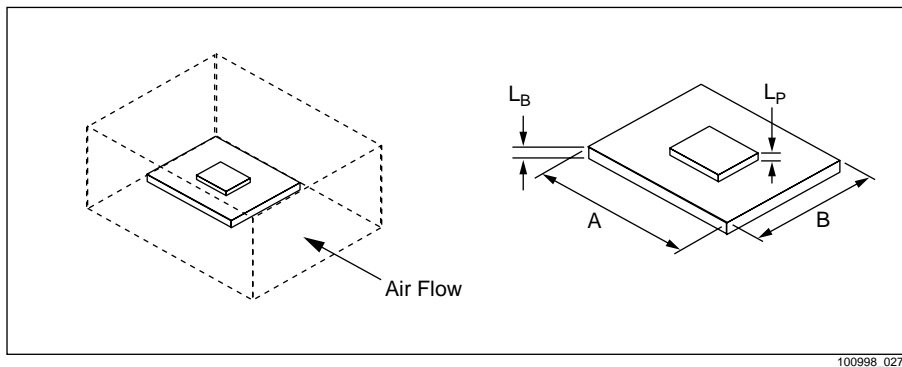

B.2.4.2 Thermal Test Boards Two different test boards have been used to evaluate package thermal performance for both worst and best conditions. [Table B-2](#) lists specifications of these test boards.

Table B-2. Specification for a Two-Layer Test Board

Drawing Number TR03-T1	
Substrate Material	FR-4
Thickness	1.6 mm
Stackup (signal layers, Cu planes)	1S0P
Cu Coverage (signal layer—top/bottom)	10%
Cu Coverage (power/ground layer)	100%
Inner Cu Thickness (spec)	35 x 3.5

Table B-3. Specification for a Four-Layer Test Board

Drawing Number TR03-T2	
Substrate Material	FR-4
Thickness	1.6 mm
Stackup (signal layers, Cu planes)	1S2P
Cu Coverage (signal layer—top/bottom)	10%
Cu Coverage (power/ground layer)	100%
Inner Cu Thickness (spec)	35 x 3.5

B.2.5 Package Thermal Performance

B.2.5.1 Calculation Guidelines

Maximum junction temperature can be calculated as:

$$T_j = P \times \theta_{ja} + T_a$$

Where:

θ_{ja} = Equivalent Package Thermal Resistance (C/W)

T_j = Maximum Junction Temperature (C)

T_a = Ambient Temperature (C)

P = Package Total Power Dissipation Value (W)

B.2.5.2 Package Thermal Resistance

Delco thermal test chips are used to estimate package thermal performance. [Table B-4](#) lists thermal die specifications.

Table B-4. Specification for Delco Thermal Test Chips

Dimensions	3.81 mm x 3.81 mm	6.35 mm x 6.35 mm	7.8 mm x 7.8 mm
Thickness	0.33 mm	0.45 mm	0.5 mm

[Figure B-6](#) illustrates package thermal resistance as a function of airflow velocity for a 48-pin ETQFP package using two different test boards, specified in [Tables B-2](#) and [B-3](#), and a prediction for a six-layer PCB design. [Figures B-7](#) and [B-8](#) illustrates the similar information for a 64- and 80-pin ETQFP package. [Table B-5](#) lists the test condition for each package type.

Figure B-6. Package Thermal Resistance as a Function of Airflow Velocity for a 48-ETQFP Package

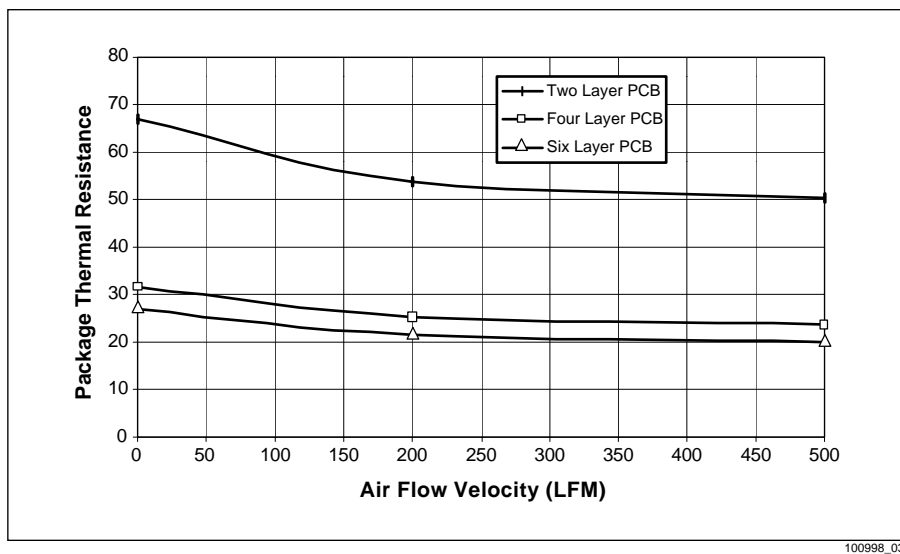

Table B-5 lists the test conditions for Figures B-6 through B-8.

Table B-5. Test Conditions

Package Type:	48 EQTFP	64 ETQFP	80 ETQFP
Body Size	7 mm x 7 mm	10 mm x 10 mm	14 mm x 14 mm
Die Size	3.81 mm x 3.81 mm	6.35 mm x 6.35 mm	7.8 mm x 7.8 mm
Die Pad Size	5 mm x 5 mm	7.50 mm x 7.50 mm	9.50 mm x 9.50 mm

Figure B-7. Package Thermal Resistance as a Function of Airflow Velocity for an 64 ETQFP

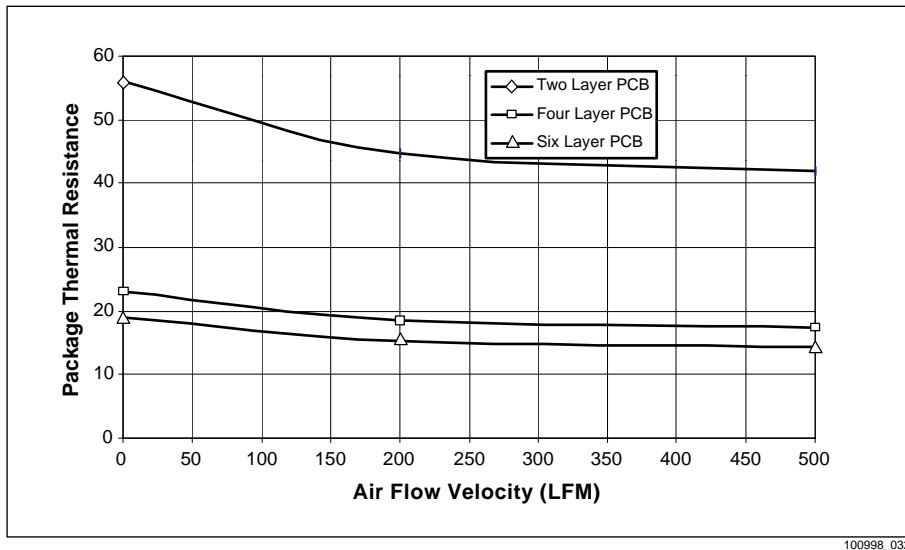
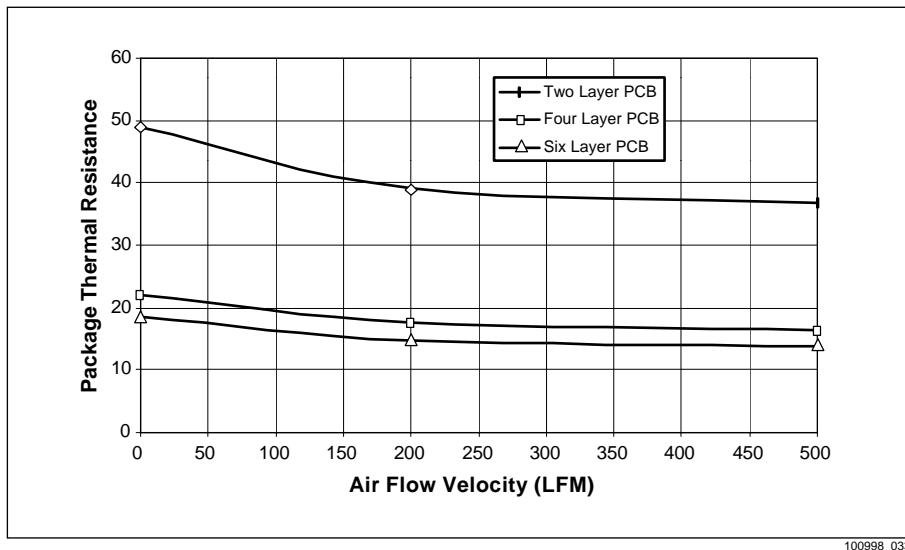

Figure B-8. Package Thermal Resistance as a Function of Airflow Velocity for an 80 ETQFP



B.3 Solder Stencil Determination

Use the thickest possible solder mask, consistent with the components being assembled to the PWB surface mount process. A standoff height of 2.0–4.2 mils provides good solder joints for both the leads and the center pad. This is achieved using a stencil thickness of 5, 6, or 7 mils.

B.4 Solder Reflow Profile

The ETQFP uses the standard TQFP reflow profile because the ETQFP package construction does not add thermal mass. There is minimal additional thermal load due to the increased solder area between the exposed die pad on the package and the center pad on the PCB. [Figures B-9](#) and [B-10](#) illustrate typical IR reflow profiles for Sn63:Pb37 solder in the cases of natural convection and forced convection ovens.

Figure B-9. Typical IR Reflow Profile for Eutectic Sn63:Pb37

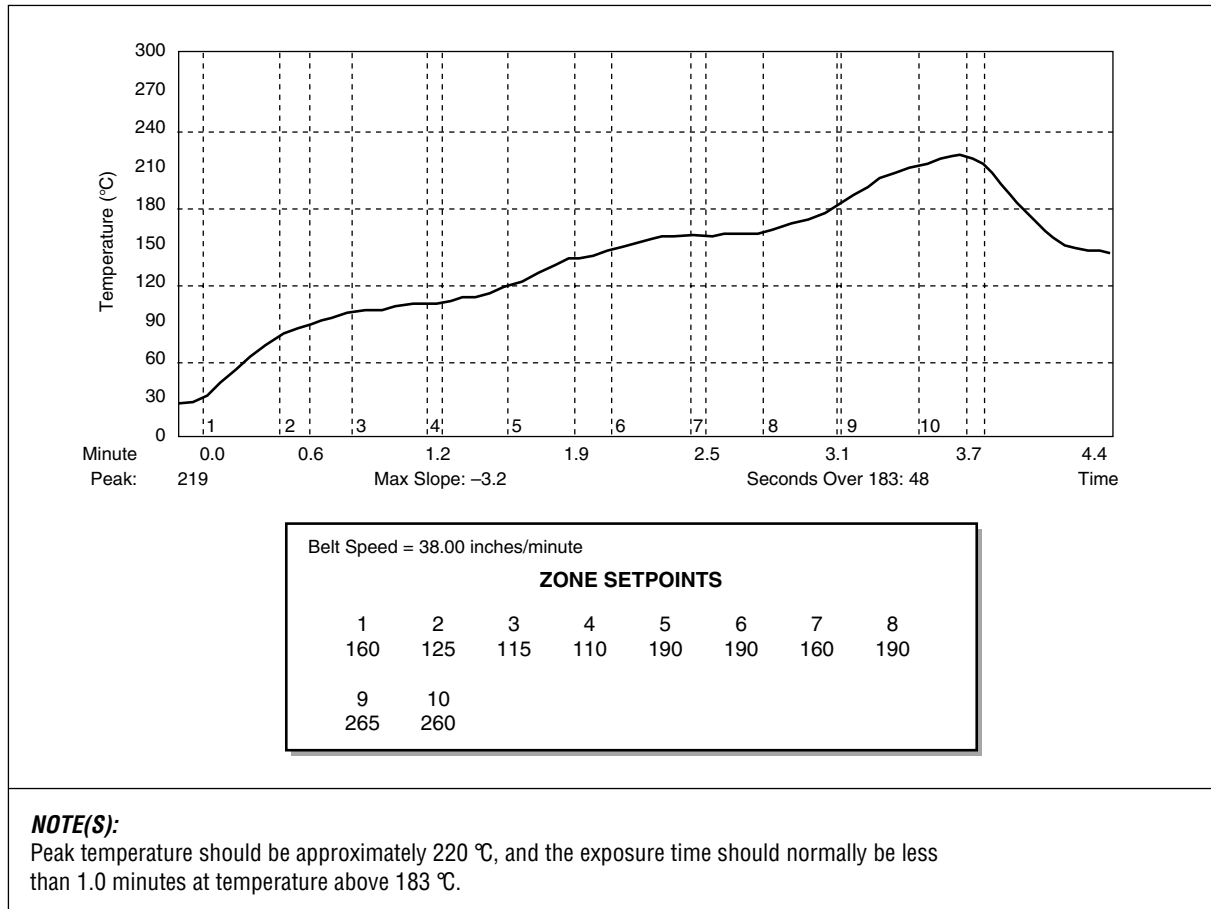

100998_025

Figure B-10. Typical Forced Convection Reflow Profile for Eutectic Sn63:Pb37

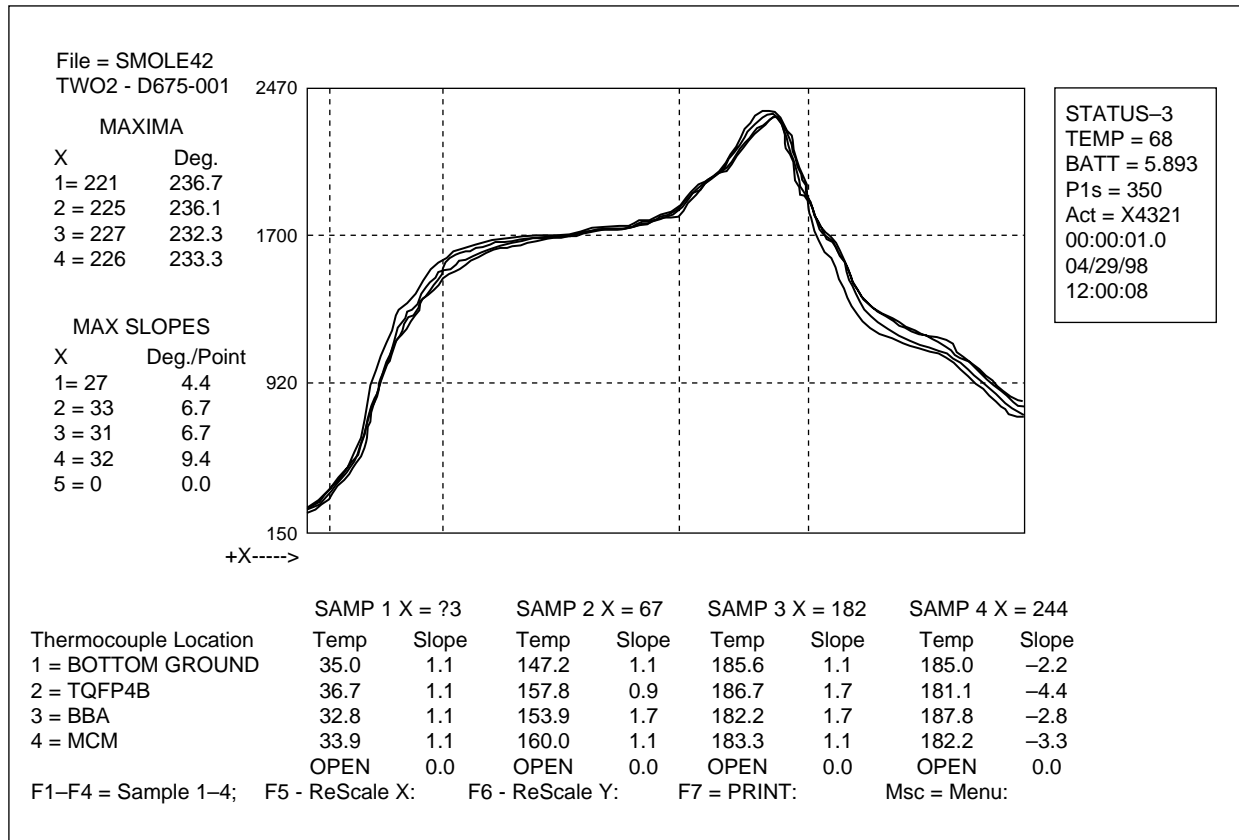

100998_026

Peak temperature should be approximately 235 °C, and the exposure time should normally be less than 1.2 minutes at temperature above 183 °C. Belt Speed = 30 inches/minute (top and bottom setting), FAN SPEED = 2500 RPM, NITROGEN LEVEL = 1200 SCFH.

ZONE 1 = 185 °C	ZONE 2 = 185 °C	ZONE 3 = 175 °C	ZONE 4 = 175 °C
ZONE 5 = 180 °C	ZONE 6 = 190 °C	ZONE 7 = 230 °C	ZONE 8 = 270 °C

Appendix C: Power Sequencing

When VGG is operated at 5V, use the power-up and power-down sequencing between VGG and VDD (DVDDC, RVDD, TVDD, VDD) as described in the diagrams below (See note below).

NOTE: VGG can exceed VDD by up to 5V ($\pm 10\%$) for short durations of less than 10 ms. VGG must never be less than VDD by more than 0.5V.

Figure C-1. Power-up sequence of VGG and VDD.

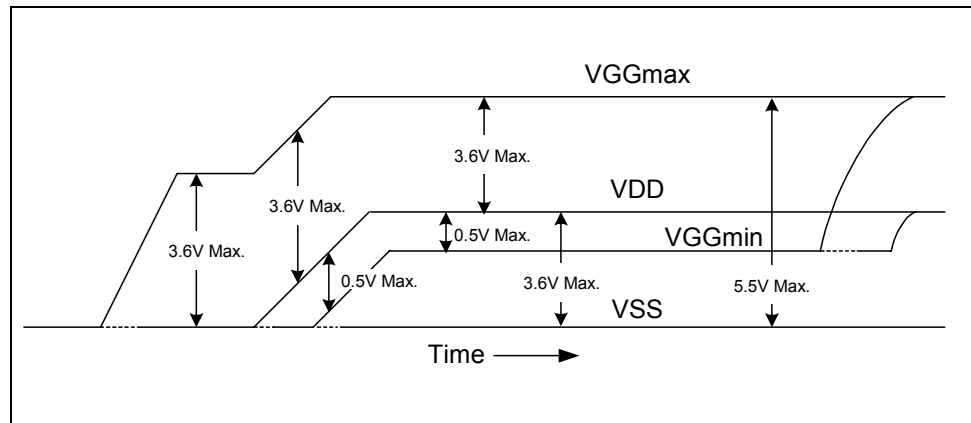
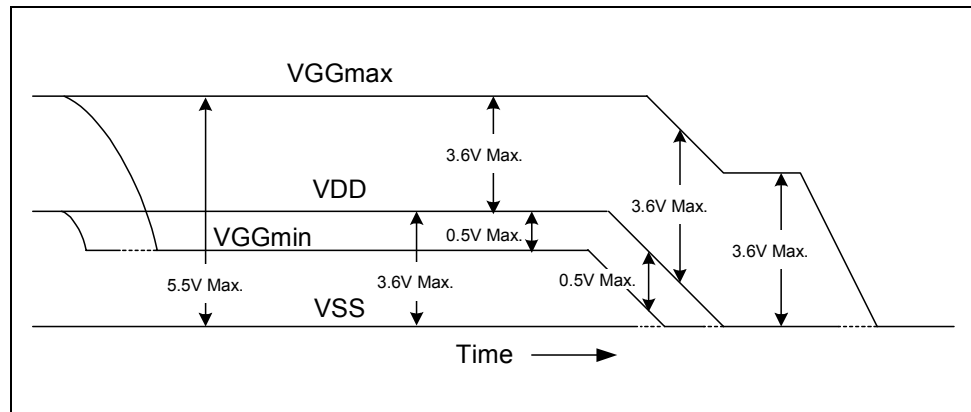

Figure C-2. Power-down sequence of VGG and VDD.



MINDSPEED™

www.mindspeed.com

General Information:
U.S. and Canada: (800) 854-8099
International: (949) 483-6996
Headquarters - Newport Beach
4311 Jamboree Rd. P.O. Box C
Newport Beach, CA. 92658-8902