

THIS DRAWING IS UNPUBLISHED. RELEASED FOR PUBLICATION
 © COPYRIGHT 19 BY AMP INCORPORATED. ALL INTERNATIONAL RIGHTS RESERVED.

LOC	DIST	P	F	ZONE	LTR	REVISIONS	DATE	APPD
AG	55				AF	DESCRIPTION		
						OBSOLETE -2 & -5 PER 0440-0129-96	7-30-97	RT

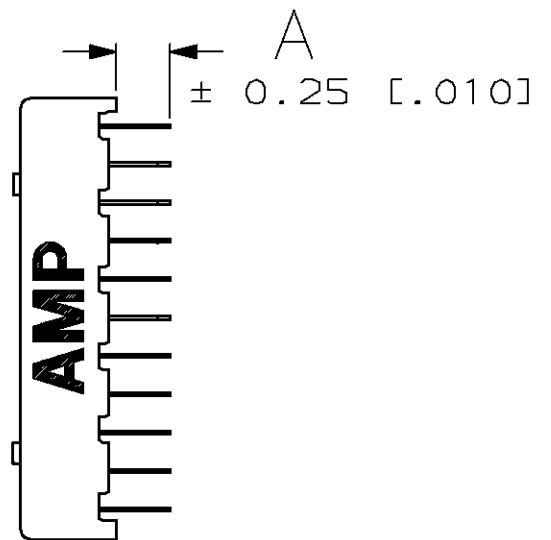

- 1 CONTACT PLATING: 0.00076 [0.000030] MIN GOLD OVER 0.00127 [0.000050] MIN NICKEL IN CONTACT AREA, 0.00381 [0.000150] MIN TIN-LEAD OVER 0.00127 [0.000050] MIN NICKEL IN SOLDER TAIL AREA.
- 2 FOR ROBOTIC ASSEMBLY, MINIMUM HOLE SIZE MUST BE INCREASED, CONSULT AMP ENGINEER.
- 3. SEE SHEET 2 FOR HOLE PATTERNS.

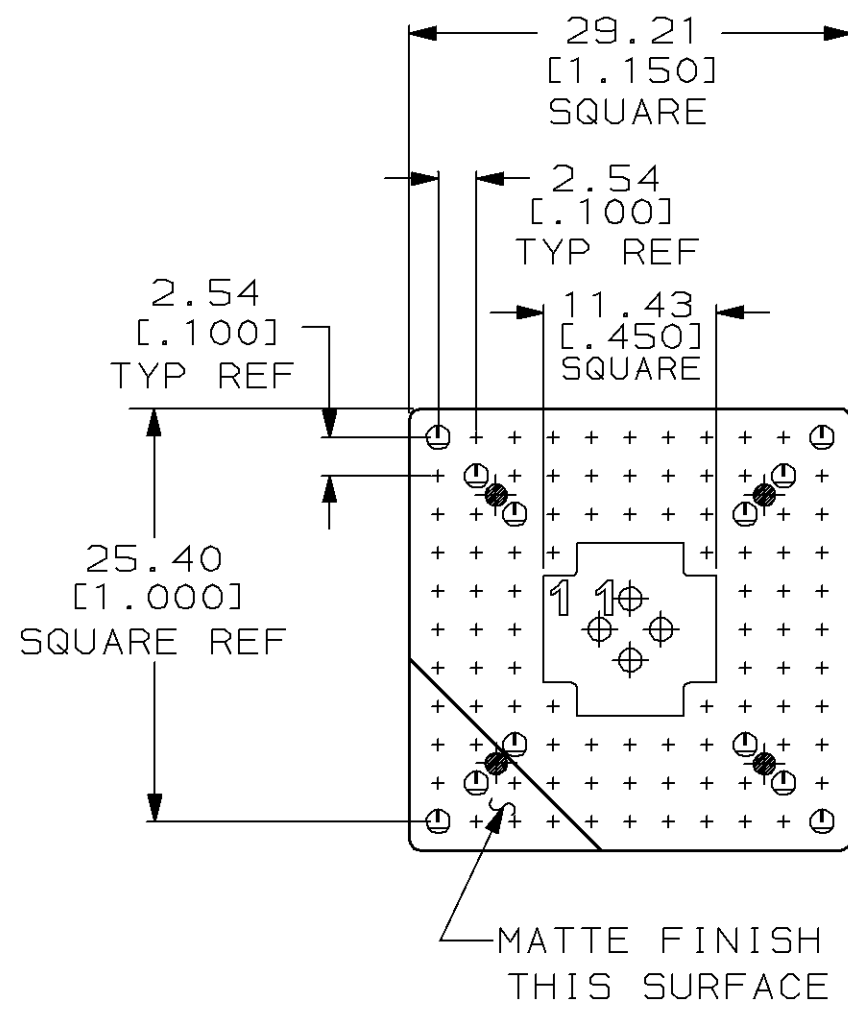
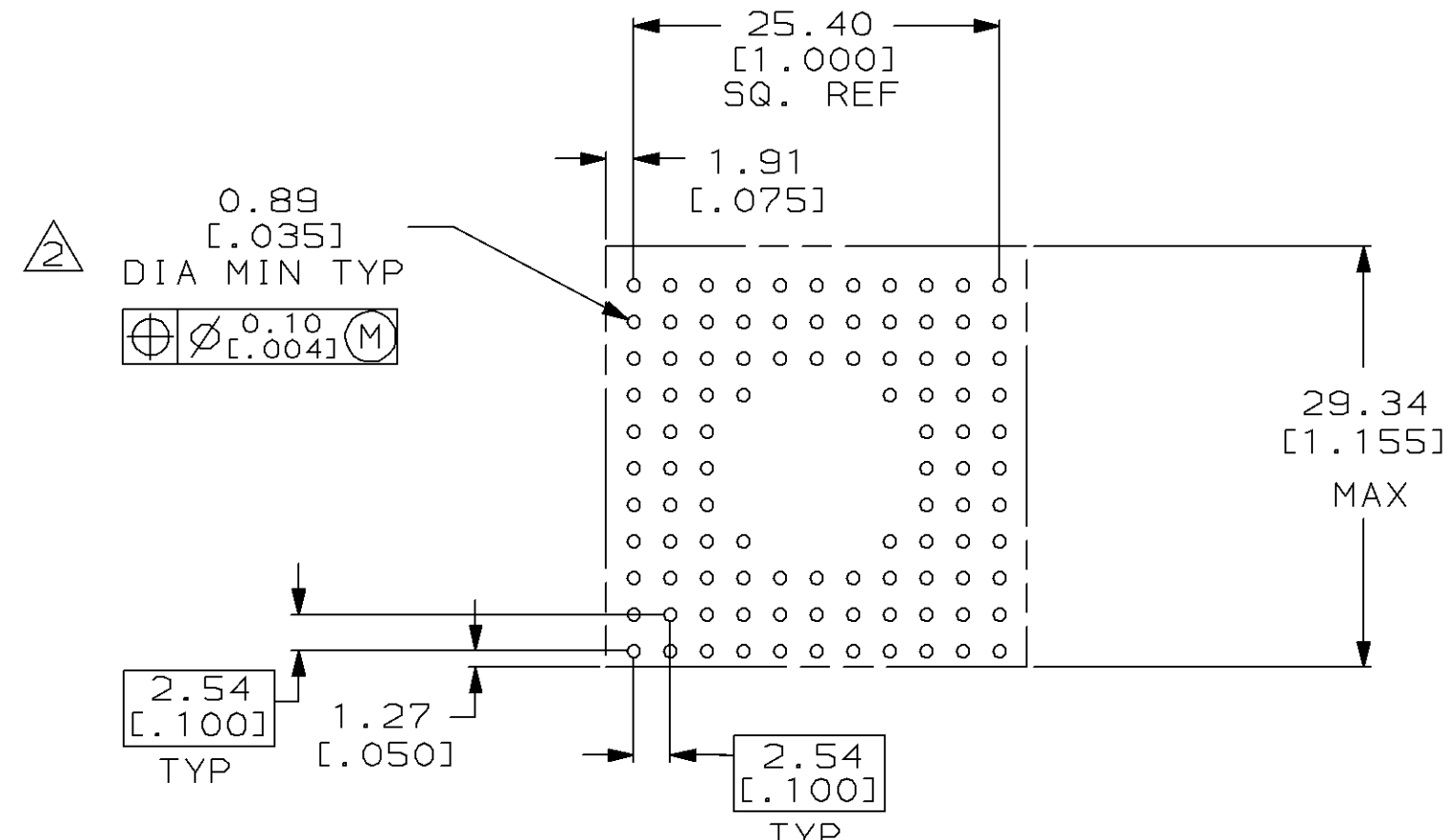

RECOMMENDED P.C. BOARD PATTERN

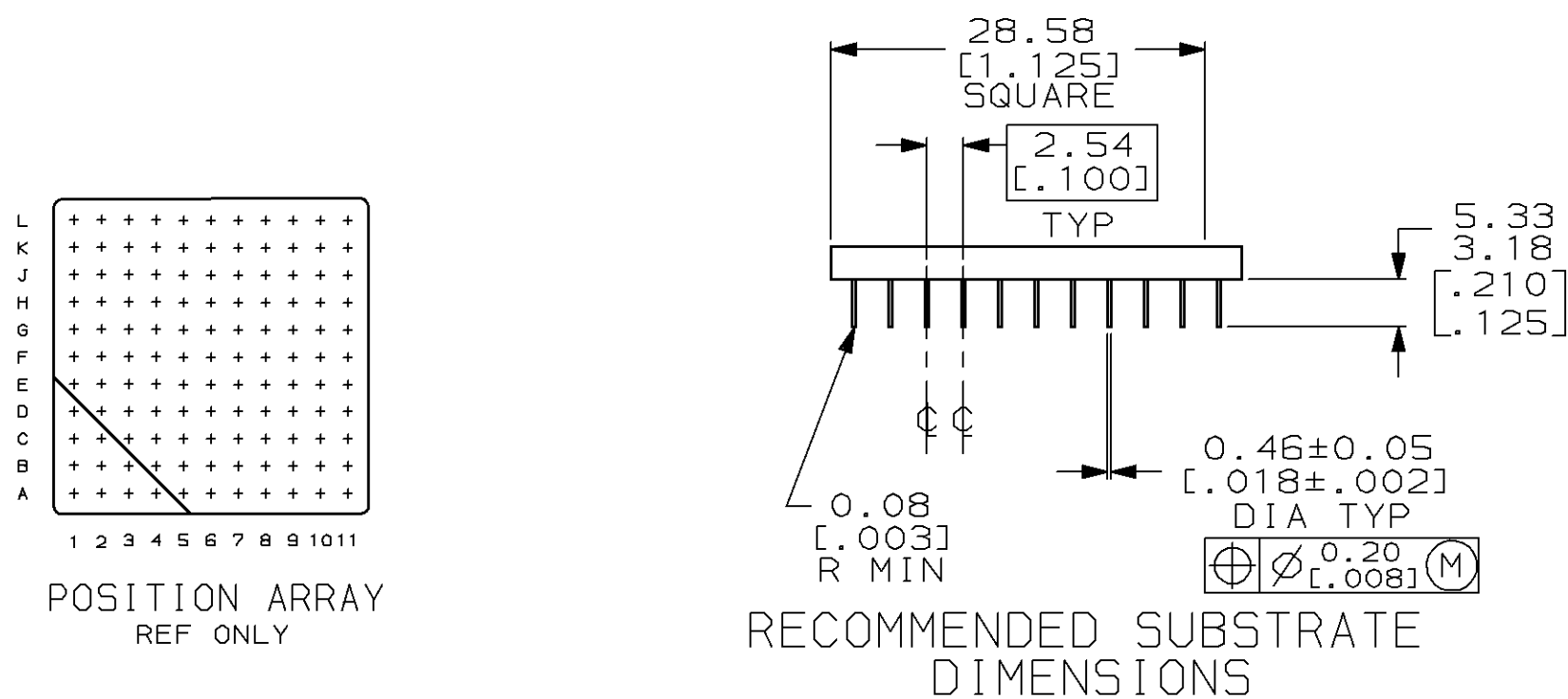
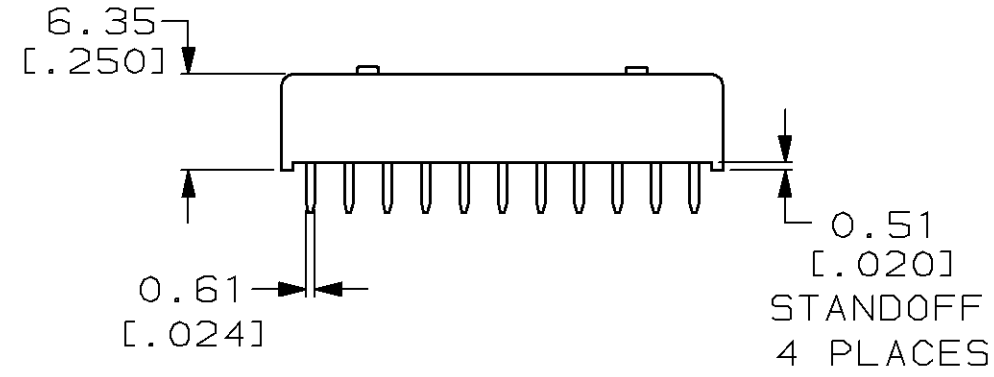

RECOMMENDED SUBSTRATE DIMENSIONS

OBSOLETE	2.79 [0.110]	97 POSITION	1-55271-5
OBSOLETE	2.79 [0.110]	100 POSITION	1-55271-4
OBSOLETE	2.79 [0.110]	73 POSITION	1-55271-3
OBSOLETE	2.79 [0.110]	96 POSITION	1-55271-2
OBSOLETE	4.32 [0.170]	68 POSITION	1-55271-1
OBSOLETE	2.79 [0.110]	72 POSITION	1-55271-0
OBSOLETE	2.79 [0.110]	121 POSITION	55271-9
SUSPD BY 55631-1			
OBSOLETE	3.56 [0.140]	85 POSITION	55271-6
OBSOLETE	2.79 [0.110]	69 POSITION	55271-5
OBSOLETE	2.79 [0.110]	68 POSITION	55271-4
OBSOLETE	2.79 [0.110]	85 POSITION	55271-3
OBSOLETE	2.79 [0.110]	84 POSITION	55271-2
OBSOLETE	2.79 [0.110]	65 POSITION	55271-1

SPECIAL FEATURE LEGEND

- + -STANDARD CAVITY, 0.76 DIA X 45° COUNTERSINK [0.030]
- ⊕ - 1.42 DIA X 0.47 HIGH BOSS [0.056] [0.0185]
- ⊖ - 1.52 DIA X 1.08 DP (COUNTERBORE) [0.060] [0.0425]

DO NOT SCALE PRINT. UNLESS SPECIFIED DIMENSIONS IN MM [INCHES] TOLERANCES ON: 2 PLC DEC ± - 3 PLC DEC ± 0.20 [0.008] ANGLES ± -	DR K.SALMON 12-8-89	AMP INCORPORATED Harrisburg, Pa. 17105	NAME SOCKET, LIF PGA, PREMIUM 11 X 11
	CHK R.MILLER 12-8-89		
MATERIAL HOUSING: 94V-0 POLYESTER CONTACTS: 0.20 [0.008] THK BeCu	APPD T.KINROSS 12-18-89	SIZE C 00779	DRAWING NO 55271
FINISH	APPLICATION SPEC -	SCALE 2:1	SHEET 1 OF 2

THIS DRAWING IS UNPUBLISHED. RELEASED FOR PUBLICATION, 19
 © COPYRIGHT 19 BY AMP INCORPORATED, HARRISBURG, PA. ALL INTERNATIONAL RIGHTS RESERVED. AMP PRODUCTS MAY BE COVERED BY U.S. AND FOREIGN PATENTS AND/OR PATENTS PENDING.

LOC	DIST	P	F	REVISIONS			DATE	APPROVED
AG	55			ZONE	LTR	DESCRIPTION		
					AF	SEE SHEET 1	-	-

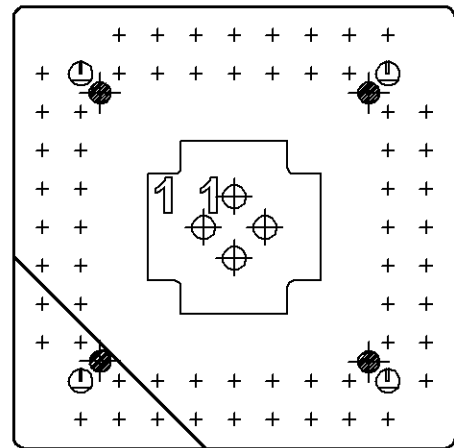

55271-1
65 POSITION

OBSOLETE

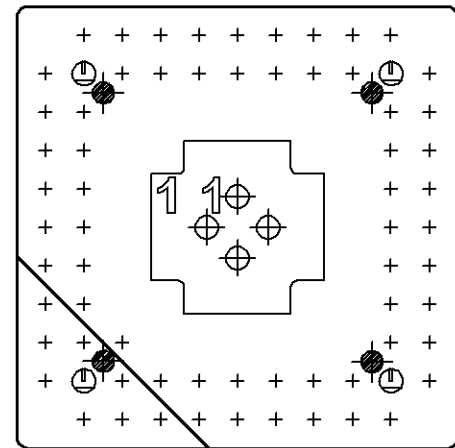

55271-5
69 POSITION

OBSOLETE

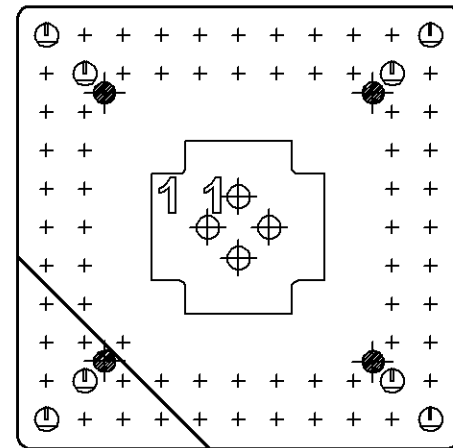

1-55271-3
73 POSITION

OBSOLETE

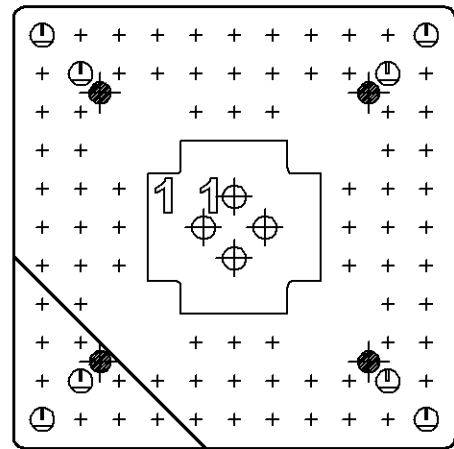

55271-2
84 POSITION

OBSOLETE

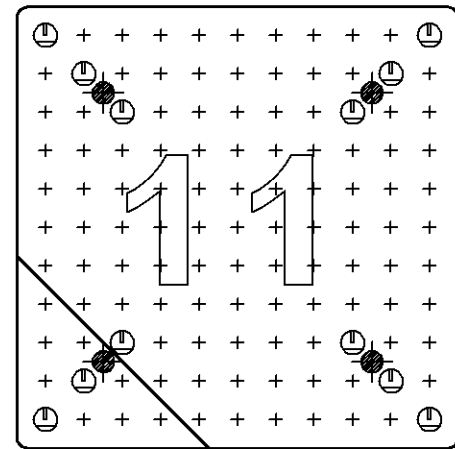

55271-9
121 POSITION

OBSOLETE

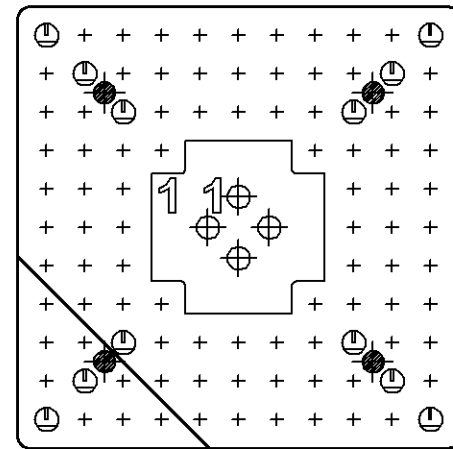

OBSOLETE 1-55271-4
100 POSITION

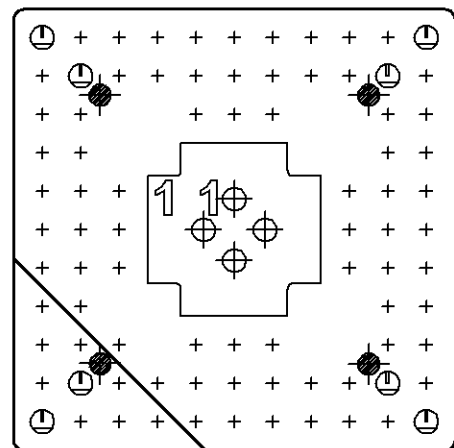

55271-3,-6
85 POSITION

OBSOLETE

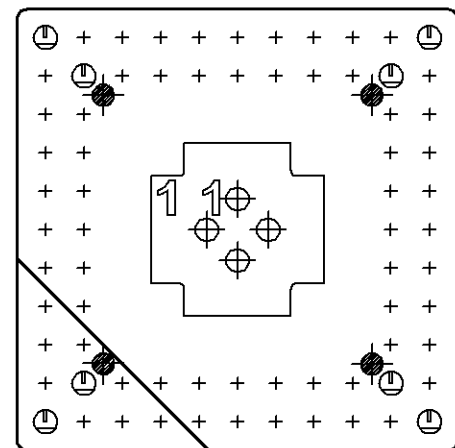

1-55271-0
72 POSITION

OBSOLETE

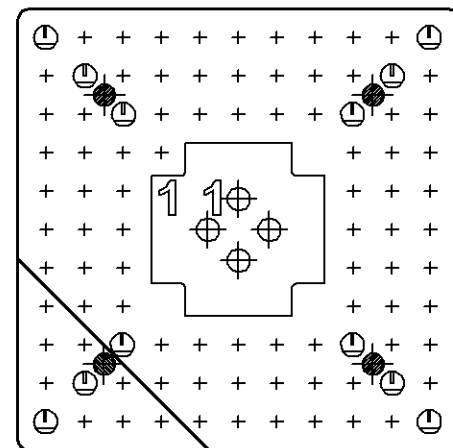

1-55271-5
97 POSITION

OBSOLETE

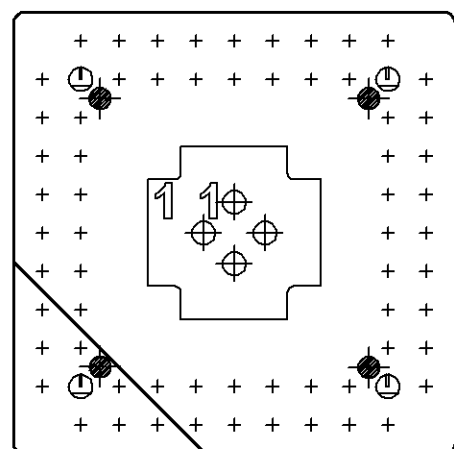

55271-4, 1--1
68 POSITION

OBSOLETE

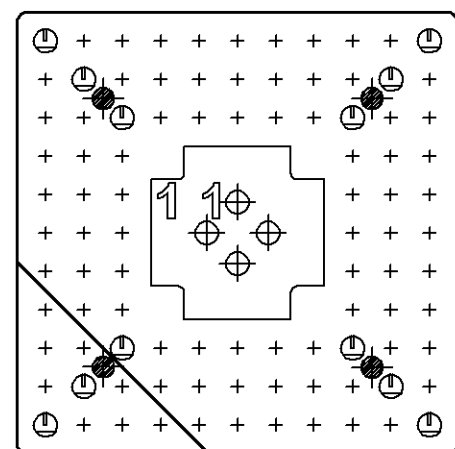

1-55271-2
96 POSITION

OBSOLETE

UNLESS OTHERWISE SPECIFIED DIMENSIONS IN MM [INCHES] TOLERANCES ON :		DR K.SALMON	12-8-89	PART NO	
2 PL DEC ± -		CHK R.MILLER	12-8-89	AMP INCORPORATED Harrisburg, Pa. 17105	
3 PL DEC ± -		APPD T.KINROSS	12-18-89	NAME	
ANGLES ± -		APPD -	-	SOCKET, LIF PGA, PREMIUM	
MATERIAL	_____	PRODUCT SPEC	-	SIZE	FSCM NO
FINISH	_____	APPLICATION SPEC	-	C	00779
		WEIGHT	-	DRAWING NO	55271
				SCALE	2:1
				SHEET	2 OF 2