

CONSUMER MICROCIRCUITS LTD

PRODUCT INFORMATION

FX205 Tone Encoder

Publication D/205/3 August 1990

**Obsolete Product
- For Information Only -**

FUNCTIONAL SCHEMATIC

FX 205 FX 205P TONE ENCODERS

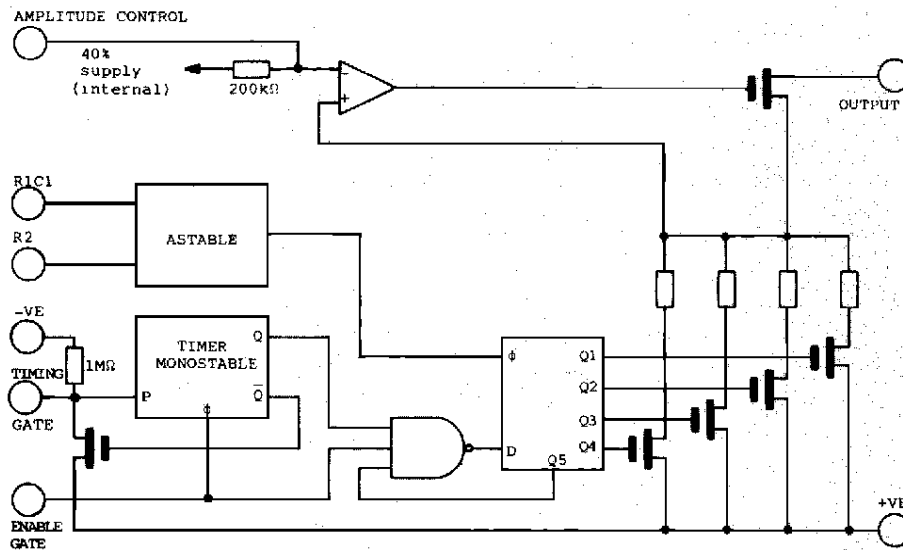

Fig. 1

FEATURES

- PSEUDO-SINEWAVE OUTPUT
- WIDE FREQUENCY RANGE
- OPTIONAL TIMED TONE BURST
- CHOICE OF PACKAGE STYLES
- ADJUSTABLE OUTPUT AMPLITUDE
- CONVERTS EXTERNAL INPUT PULSES TO SINEWAVE OUTPUT

DESCRIPTION

The FX205 and FX205P are monolithic pseudo-sinewave generators. The FX205 is encapsulated in a hermetically sealed metal can and the FX205P is packaged in a plastic D.I.L.

The circuits have an extensive range of applications encompassing telecommunications, control systems and alarm or supervisory signalling.

The output tone frequency is adjustable between 30Hz and 5kHz by using an external resistor and capacitor (R1 and C1) as illustrated in Fig. 2. Figures 4 and 5 show the component value of R1, for given values of C1 required to generate any frequency in the range. R2 is fixed at 10k ohms. The output frequency, f_o , can be obtained from

$$f_o = \frac{1}{5.6 (R_2 + 2R_1)C_1} \text{ Hertz}$$

Where R1 and R2 are expressed in megohms C1 is in microfarads and the value 5.6 is a constant of the device and is subject to a tolerance of $\pm 10\%$.

The output frequency can range from d.c. to 50kHz by providing external clock pulses to the R1 C1 pin. The input clock must be eight times the required output frequency.

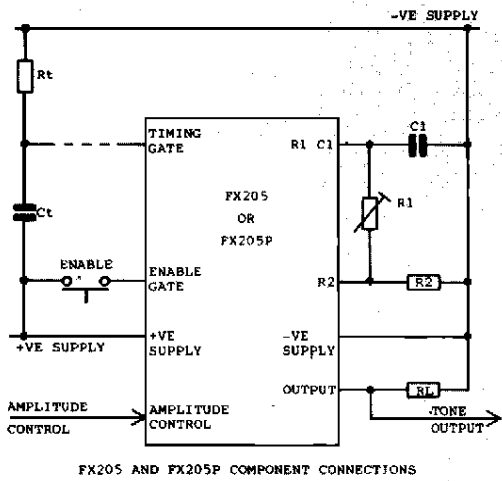

Fig. 2

The FX205 and FX205P will generate an output for the period of time that the Enable Gate input is held positive. Optionally a resistor (R_t) and capacitor (C_t) can be provided as shown on Fig. 2. This ensures that the output is generated for a minimum duration given by

$$T = 0.7 R_t C_t \text{ seconds}$$

where R_t is expressed in megohms, C_t is in microfarads, and 0.7 is a device constant (tolerance $\pm 5\%$).

The monostable is not retriggerable and a further timed period can only be initiated after completion of the original burst. Should the Enable input be held positive for longer than time T the device will continue generating a tone until disabled.

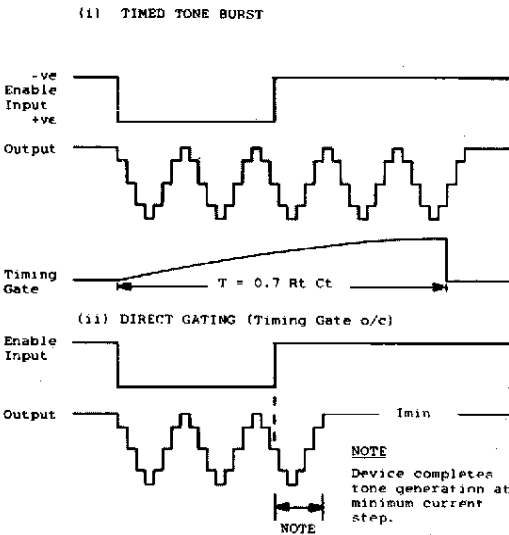

Fig. 3

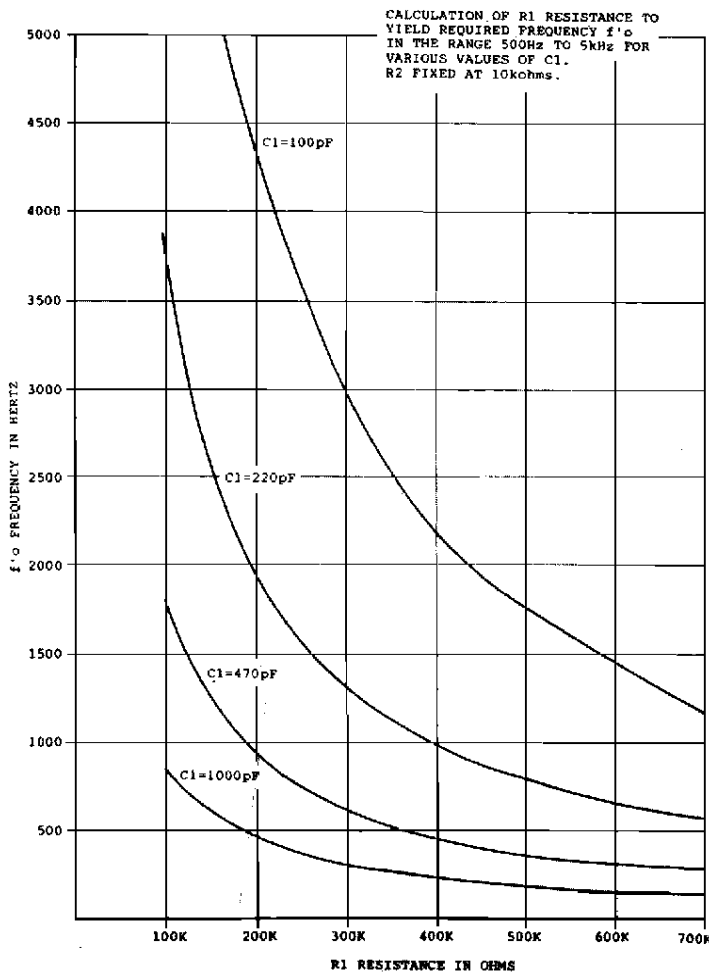

Fig. 4

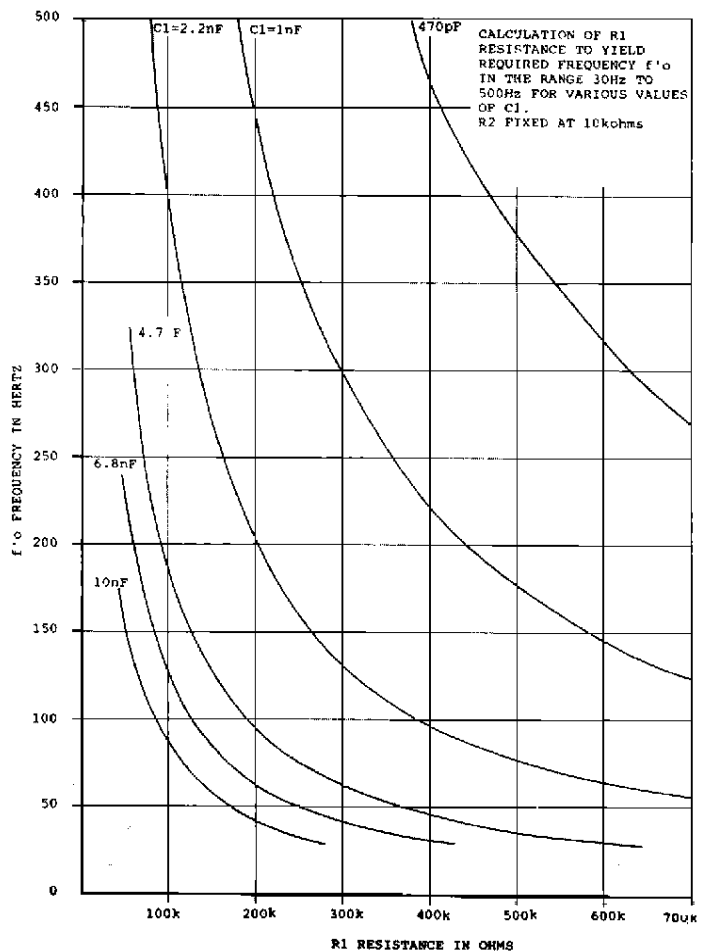

Fig. 5

MULTI-TONE OUTPUT USING A MASTER CLOCK AND PROGRAMMABLE DIVIDERS.

$$V_{out} = iR_L (S_{in1}t + S_{in2}t + S_{in3}t)$$

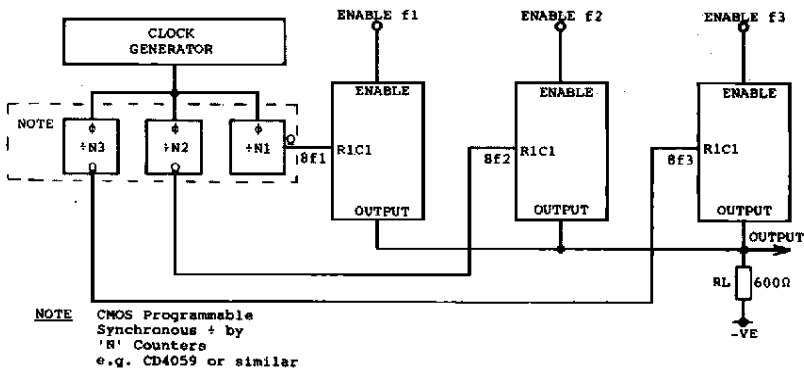
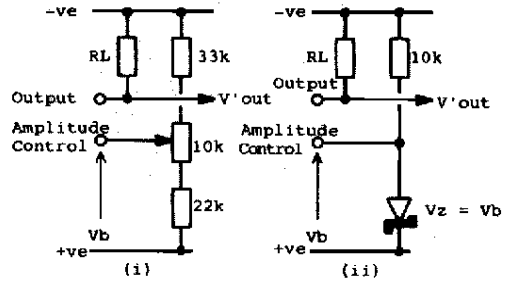

Fig. 6

EXTERNAL AMPLITUDE CONTROL



$$V'_{out} = \frac{V_b}{6800} \times R_L \text{ V.r.m.s.}$$

where R_L is in ohms
and 6800 is a device constant
(subject to $\pm 20\%$ tolerance)

Fig. 7

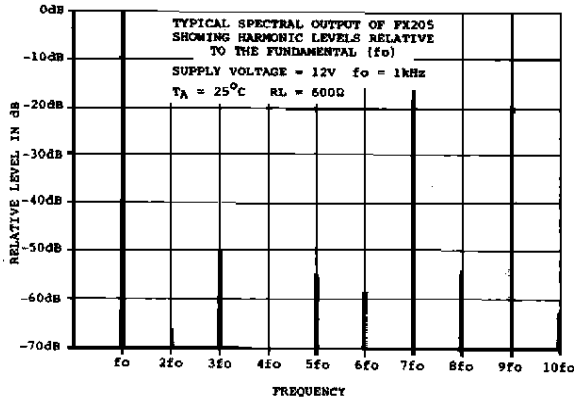

Fig. 8

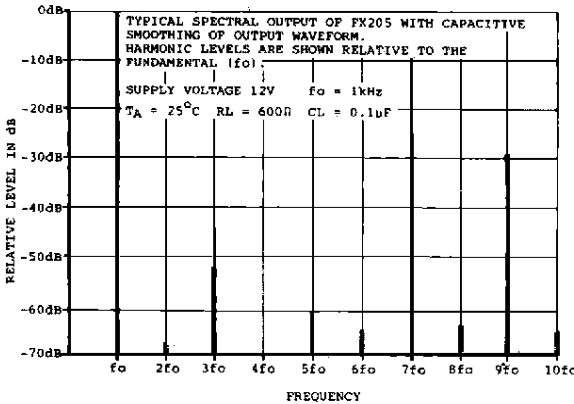
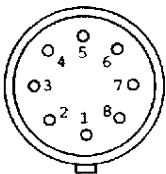

Fig. 9

The output is generated in the form of sinusoidally weighted current steps. A typical output spectrum is shown in Fig.8, while Fig. 9 shows the effect on the harmonic content of a capacitor in parallel to R_L . Multiple tones can be mixed by connecting outputs to a common load resistor as shown in Fig. 6. The circuit is designed to always start and end tone generation at the minimum current step (i.e. most negative output voltage as shown in Fig. 3).

The output voltage can be adjusted over a range of $\pm 35\%$ from the nominal level by applying a voltage (V_b) to the Amplitude Control input as shown in Fig. 7. V_b can range from 25% to 55% of the supply voltage (internal bias is 40% nominally).

FX205 PIN CONFIGURATION



1. R1 C1
2. -VE Supply
3. Output
4. Amplitude Control
5. +VE Supply
6. Timing Gate
7. Enable Gate
8. R2

View on pins

Note: Pin 5 is internally connected to the case.

Fig. 10

FX205P PIN CONFIGURATION

(TOP VIEW)

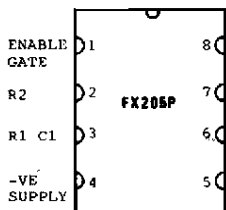

Fig. 11

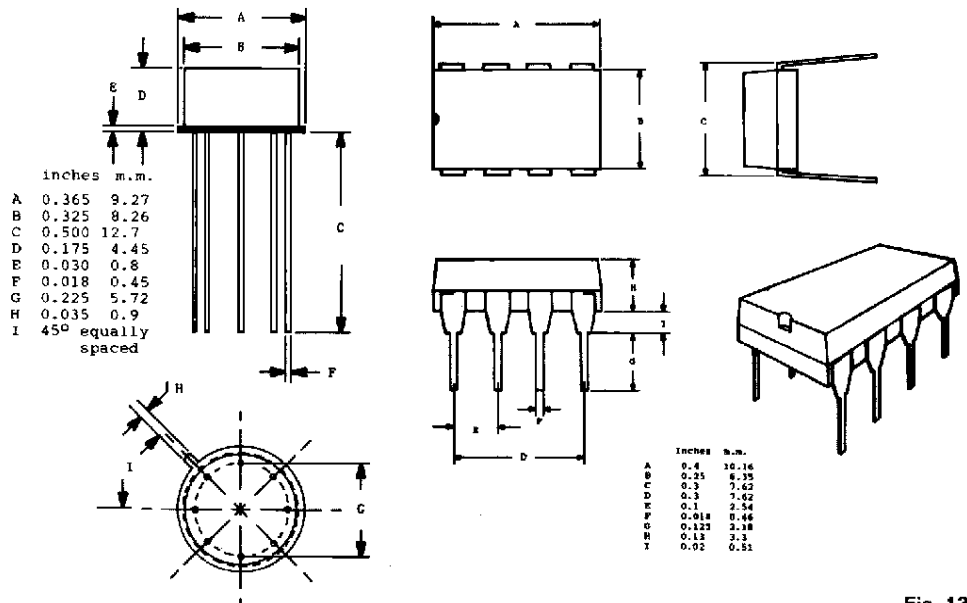

Fig. 13

SPECIFICATION

MAXIMUM RATINGS. Exceeding maximum rating may result in device damage.

Maximum Voltage between any pin and +ve supply		-20v to +0.3v
Operating Temperature Range	FX205	-30°C to +85°C
	FX205P	-10°C to +60°C
Storage Temperature Range	FX205	-55°C to +125°C
	FX205P	-40°C to + 85°C
Device Dissipation at 85°C at 60°C	FX205	200mW
	FX205P	120mW

OPERATING CHARACTERISTICS

Unless otherwise stated Supply Voltage = 12v T'amb = 25°C
Output Frequency ≤ 3kHz

SYMBOL	CHARACTERISTICS	MIN.	TYP.	MAX.	UNITS
Vs	Supply Voltage (+ve supply = 0v)	-10	-12	-15	V
Is	Supply Current (no load current)		7		mA
fo	Output Frequency Range (determined by R1, C1 & R2)	30		5k	Hz
fo	Output Frequency Range (determined by external clock)	0		50k	Hz
Δfo	Frequency Variation per 1% change in Vs		0.06		%
Δfo	Frequency Variation per 1°C change in temperature		0.015		%
	Pulse Width of External Clock	1.25			μs
Vo	Output Voltage (RL = 600Ω, Amplitude Control Pin o/c)		550		mV r.m.s.
ΔVo	Output Amplitude adjustment range (Vb applied to Amplitude Control Pin)		±35		%
	Input Level to Enable Device			-1.5	V
	Input Level to Disable Device	-9			V
	Enable Input Pulse width	10			μs
	Input Impedance of Enable Input		100k		Ω
	Value of R1	47k		1M	Ω
	Value of R2		10k		Ω
	Value of RL		600	1k	Ω
	Value of Rt	100k		10M	Ω
	Value of C1	0.1		10	nF
	Value of Ct	0.1		1500	nF
T	Period of Timed Tone Burst (T = 0.7 Rt Ct)	1/fo		10	s

CML does not assume any responsibility for the use of any circuitry described. No circuit patent licences are implied and CML reserves the right at any time without notice to change the said circuitry.