

Low Power, Low EMI, TFT-LCD Column Driver with RSDS Inputs, 64 Grayshades, and 384 Outputs for XGA/SXGA Applications

General Description

The FPD33584 Column Driver is a direct drive, 64 gray level, 384 output, TFT-LCD column driver with an RSDS® data interface. It provides the capability to display 262,144 colors (18-bit color) with a large dynamic output range for twisted nematic applications. When used in a bank with other FPD33584 column drivers, the FPD33584 can support XGA (8 drivers) or SXGA (10 drivers) applications. Output voltages are gamma corrected to provide a direct mapping between digital video and LCD panel brightness. The 85MHz operating frequency allows the FPD33584 to meet the requirement of high refresh rate applications (i.e. XGA monitors with a 75Hz refresh rate).

An RSDS (Reduced Swing Differential Signaling) interface is used between the timing controller and the column driver to minimize EMI and reduce power.

Features

- RSDS (Reduced Swing Differential Signaling) data bus for low power, reduced EMI and small PCB foot print
- 85MHz maximum operating frequency at $V_{DD1}=3.0V$ (70MHz at $V_{DD1}=2.7V$)
- Pin compatible with Samsung S6C0666
- Ideal for XGA and SXGA applications
- Supports notebook and monitor applications
- Smart Charge Conservation for low power consumption
- 64 Gray levels per color (18-bit color)
- Supports both Dot and N-Line inversion
- Four externally programmable gamma curves
- Low offset, High voltage outputs for high contrast in a large range of display panel applications
- Optional, high current, repair amplifiers

System Diagram

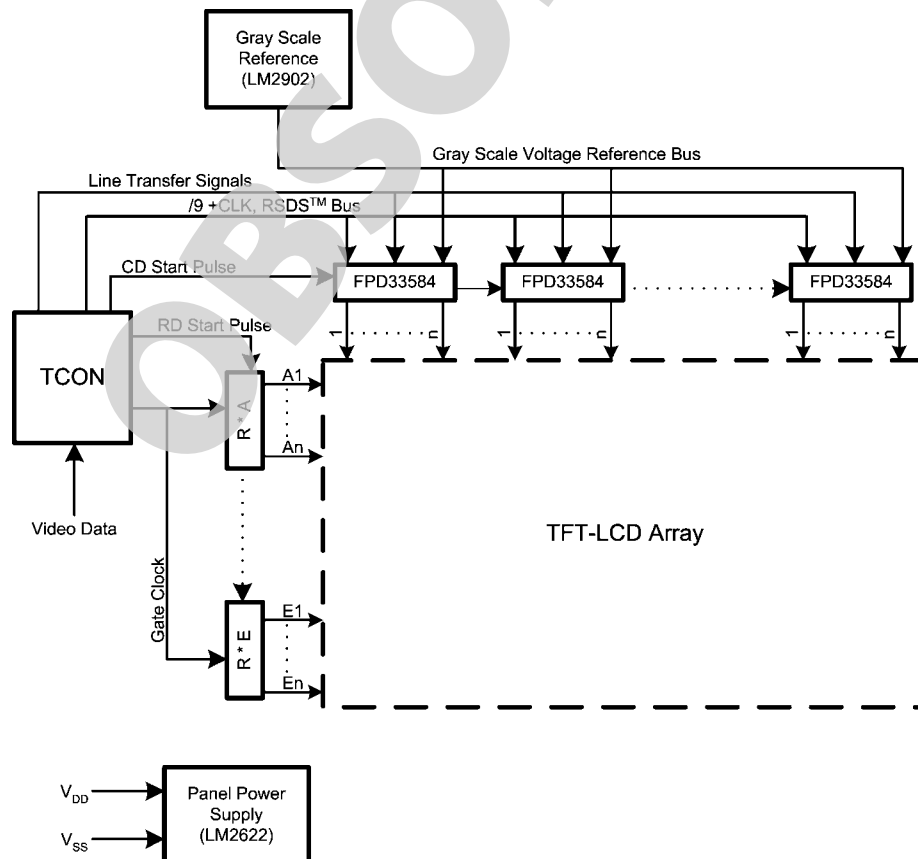

RSDS® is a registered trademark of National Semiconductor Corporation.

20043201

Absolute Maximum Ratings (Note 1)

Analog Supply, (V_{DD2}) (Note 2)	-0.3V to +11.5V
Logic Supply, (V_{DD1}) (Note 2)	-0.3V to +5.0V
Low-Polarity RDAC Reference Voltages, (V_{GMA6} to V_{GMA5}) (Note 2)	-0.3V to $0.5V_{DD2}$
High-Polarity RDAC Reference Voltages, (V_{GMA1} to V_{GMA5}) (Note 2)	$0.5V_{DD2} - 1.0V$ to $V_{DD2} + 0.3V$
RDAC Current (All Gamma Voltage Taps), (I_{GMA} to I_{GMA10})	-2.5mA to 2.5mA
Input Voltage (Digital Logic), (V_{IN}) (Note 2)	-0.3V to $V_{DD1} + 0.3V$
Output Voltage, (V_{OUT}) (Note 2)	-0.3V to $V_{DD2} + 0.3V$

Output Current (Analog), (I_{OUT})	-7mA to +7mA
Storage Temperature Range, (T_S)	-55°C to +125°C

Note 1: "Absolute Maximum Ratings" are those values beyond which the safety of the device cannot be guaranteed. They are not meant to imply that the devices should be operated at these limits. The table of "Electrical Characteristics" specifies conditions of device operation.

Note 2: Absolute voltages referenced to $V_{SS1} = V_{SS2} = 0.0V$.

Recommended Operating Conditions

	Min	Typ	Max	Units
Logic Supply Voltage (V_{DD1})	2.7	3.3	3.6	V
Supply Voltage (V_{DD2})	7.5		10.5	V
Operating Temperature (T_A)	-10	+25	+70	°C

DC Electrical Characteristics

Digital Electrical Characteristics

Symbol	Parameter	Conditions	Min	Typ	Max	Units
V_{IH}	Logic Input High Voltage		$0.7 V_{DD1}$			V
V_{IL}	Logic Input Low Voltage				$0.3 V_{DD1}$	V
V_{OH}	Logic Output High Voltage	$I_{OH} = -0.5mA$	$V_{DD1} - 0.5$			V
V_{OL}	Logic Output Low Voltage	$I_{OL} = 0.5mA$			0.5	V
I_{DD1}	Logic Current	(Note 3)		8.0	12.0	mA
I_{IH}	Input Leakage	$V_{DD1} = 3.6V, V_{IN} = 3.6V$	-1		1	μA
I_{IL}	Input Leakage	$V_{DD1} = 3.6V, V_{IN} = 0V$	-1		1	μA
C_{IN}	Input Capacitance	All logic pins		2		pF

Note 3: CLK frequency = 67MHz, $V_{DD1} = 3.3V$, $V_{SS1} = V_{SS2} = 0.0V$, line time = 18μs, data = all 1's for 4 lines followed by all 0's for 4 lines.

RSDS Characteristics

Symbol	Parameter	Conditions	Min	Typ	Max	Units
$V_{IH_{RSDS}}$	RSDS High Input Voltage	$V_{CM_{RSDS}} = 1.2V$ (Note 4) see Figure 1	100	200		mV
$V_{IL_{RSDS}}$	RSDS Low Input Voltage	$V_{CM_{RSDS}} = 1.2V$ (Note 4) see Figure 1		-200	-100	mV
$V_{CM_{RSDS}}$	RSDS Common Mode Input Voltage Range	$V_{IH_{RSDS}} = +100mV, V_{IL_{RSDS}} = -100mV$ (Note 5) see Figure 1	$V_{SS1} + 0.1$		$V_{DD1} - 1.3$	V
IDL	RSDS Input Leakage Current	DxxP, DxxN, CLKP, CLKN	-10		10	μA

Note 4: $V_{CM_{RSDS}} = (V_{CLKP} + V_{CLKN})/2$ or $(V_{DxxP} + V_{DxxN})/2$.

Note 5: $V_{IH_{RSDS}}$ and $V_{IL_{RSDS}}$ are referenced to $V_{CM_{RSDS}}$.

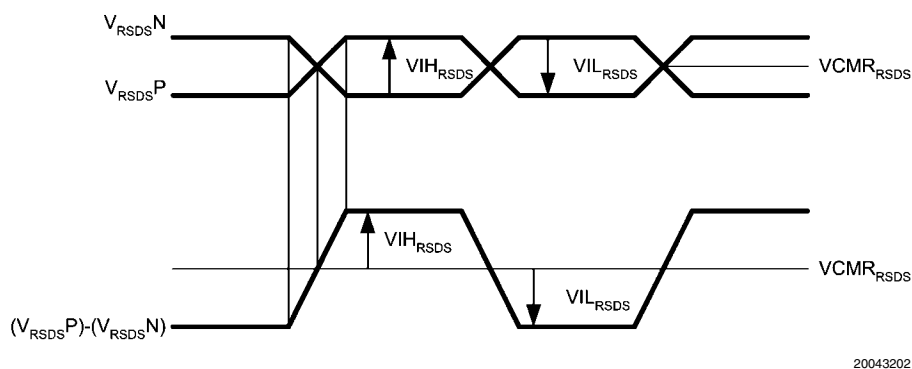

FIGURE 1. RSDS Signal Definition

Analog Electrical Characteristics

Symbol	Parameter	Conditions	Min	Typ	Max	Units
I_{DD2}	Supply Current Consumption	(Note 6)		5.0	12.0	mA
V_{GMA1}	Upper RDAC High Side Input	(Note 7)	$V_{DD2}/2 + 0.2$		$V_{DD2} - 0.2$	V
V_{GMA5}	Upper RDAC Low Side Input	(Note 7)	$V_{DD2}/2 + 0.2$		$V_{DD2} - 0.2$	V
V_{GMA6}	Lower RDAC High Side Input	(Note 7)	0.2		$V_{DD2}/2 - 0.2$	V
V_{GMA10}	Lower RDAC Low Side Input	(Note 7)	0.2		$V_{DD2}/2 - 0.2$	V
C_{LOAD}	Output Capacitive Load		30		150	pF
V_{OUT}	Output Voltage Range		$V_{SS2} + 0.2$		$V_{DD2} - 0.2$	V
R_{DAC}	RDAC References (V_{GMA1} to V_{GMA5} and V_{GMA6} to V_{GMA10})	each	12.0	15.0	18.0	k Ω
V_{pperr}	Output Peak to Peak Error (gray levels 0 through 58)	$V_{GMA1} = V_{DD2} - TBDV$ $V_{GMA10} = V_{SS2} + TBDV$		± 3	± 12	mV
	Output Peak to Peak Error (gray levels 59 through 63)	(Note 8)		± 5	± 25	mV
$V_{parterr}$	Output Part to Part Error	(Note 9)			± 5	mV
$I_{OUT RP}$	Repair Buffer Output Current	(Note 10)	± 2	± 3		mA

Note 6: $V_{DD2} = 10V$, $V_{DD1} = 3.3V$, $f_{CLK} = 67MHz$, line time = $18\mu sec$, data = maximum output swing (GMA1 to GMA10), [TIME1, TIME0] = [0, 1] (charge sharing of 32 clock cycles)

Note 7: The following relationship must be maintained between the reference voltages: $V_{DD2} > V_{GMA1} > V_{GMA2} > V_{GMA3} > V_{GMA4} > V_{GMA5} > V_{GMA6} > V_{GMA7} > V_{GMA8} > V_{GMA9} > V_{GMA10} > V_{SS2}$

Note 8: V_{pperr} is meant to reflect the error in peak-to-peak output voltage for each gray level when the output swings from the high value V_{Hxx} to the low value V_{Lxx} . This parameter applies to every output on the die. The typical value represents one standard deviation from ideal based on tester data. The maximum value is a constraint of the test environment, not the performance of the part.

Note 9: $V_{parterr}$ is meant to guarantee the part-to-part output variation. The average of all outputs at gray level 32 is compared to a nominal gray level 32 value. The difference is $V_{parterr}$.

Note 10: Current into device pins is defined as positive. Current out of device pins is defined as negative. $|V_{OUT} - V_{IN}| > 500mV$.

AC Electrical Characteristics

Digital AC Characteristics

Symbol	Parameter	Conditions	Min	Typ	Max	Units
PW_{CLK}	Clock Period	$V_{DD1} = 2.7$ to $3.0V$	14			ns
PW_{CLK}	Clock Period	$V_{DD1} = 3.0$ to $3.6V$	11.7			ns
$PW_{CLK(L)}$	Low Clock Pulse Width		40%		60%	PW_{CLK}
$PW_{CLK(H)}$	High Clock Pulse Width		40%		60%	PW_{CLK}
t_{setup1}	RSDS Data Setup Time		2			ns
t_{hold1}	RSDS Data Hold Time		0			ns
t_{setup2}	ENIOx Setup Time		2			ns
t_{hold2}	ENIOx Hold Time		2			ns
t_{PLH1}	Start Pulse Fall Delay	$C_{LINE} = 15$ pF			8	ns
PW_{DIO}	ENIOx Pulse Width		1		2	PW_{CLK}
PW_{CLK1}	LOAD Pulse Width		$5 T_{CLK}$		$5\mu s$	
t_{LDT}	Last Clock to LOAD Delay		1			PW_{CLK}
t_{DENSU}	LOAD to First ENIO Setup		2			PW_{CLK}
$t_{POL-CLK1}$	POL-CLK1 Time		14			ns

Analog AC Characteristics

Supplies: $V_{SS1} = V_{SS2} = 0.0V$, $V_{DD1} = 3.3V$, $V_{DD2} = +10.0V$.

Symbol	Parameter	Conditions	Min	Typ	Max	Units
$t_{settle\ 90\%}$	Output Settling Time to 90% of Final Value	Figure 2 (Note 11)			6	μs
$t_{6-bit\ accy}$	Output Settling Time to 6-bit accuracy	Figure 2 (Note 11)			10	μs
$t_{RP\ 90\%}$	Repair Line Output Settling Time to 90% of Final Value	$C_{LOAD} = 150$ pF, (Note 11)			6	μs
$t_{RP\ 6-bit\ accy}$	Repair Line Output Settling Time to 6-bit accuracy	$C_{LOAD} = 150$ pF, (Note 11)			10	μs

Note 11: $V_{GMA1} = 9.8V$, $V_{GMA10} = 0.2V$, $V_{GMA5} = 5.2V$, $V_{GMA6} = 4.8V$, [TIME0, TIME1] = [0,1].

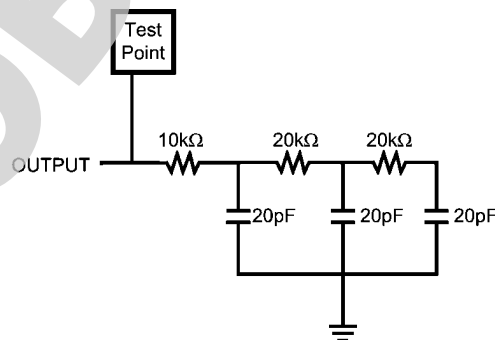

20043211

FIGURE 2. Test Circuit for Output Settling Time Measurements

Timing Diagrams

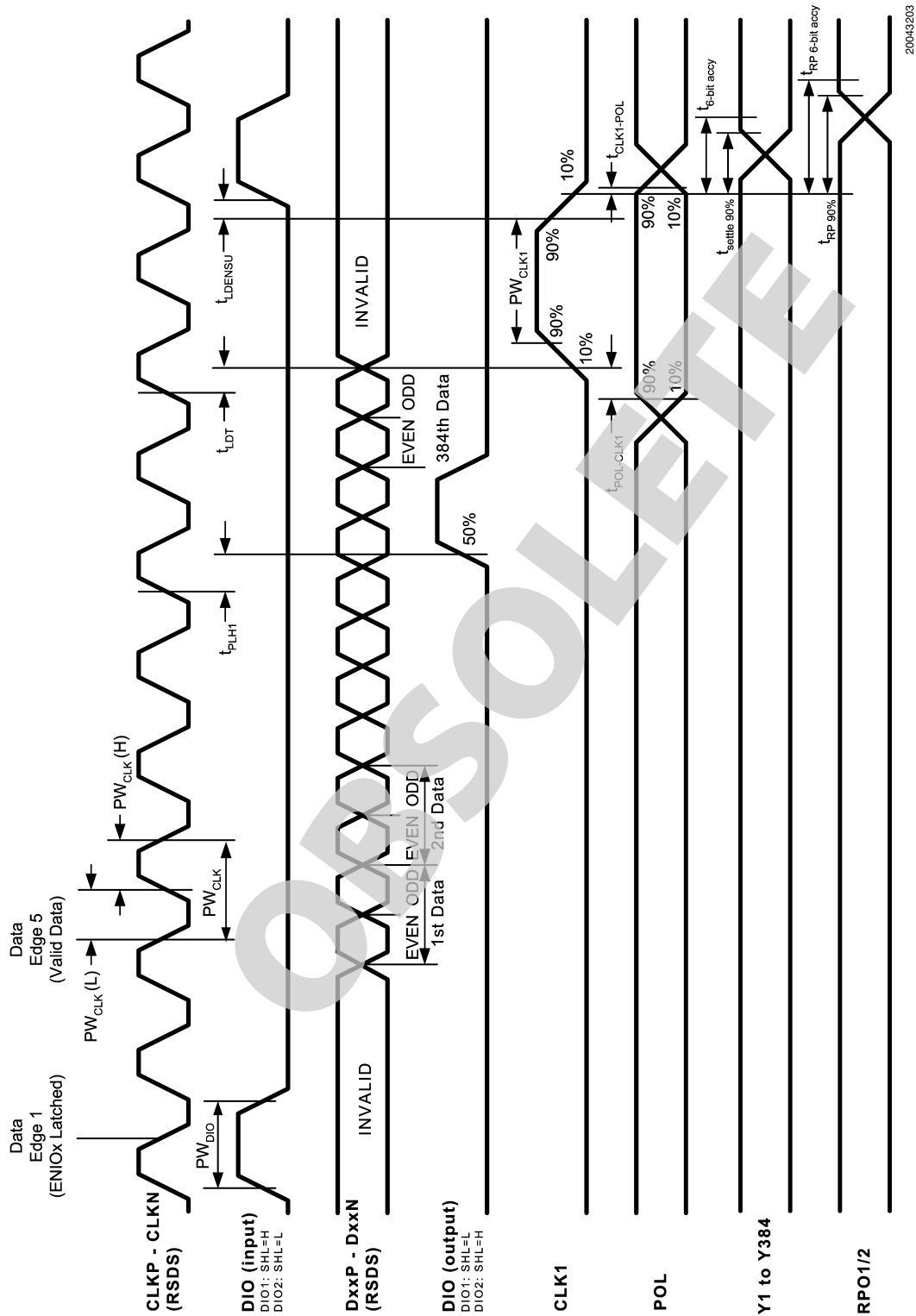

Block Diagram

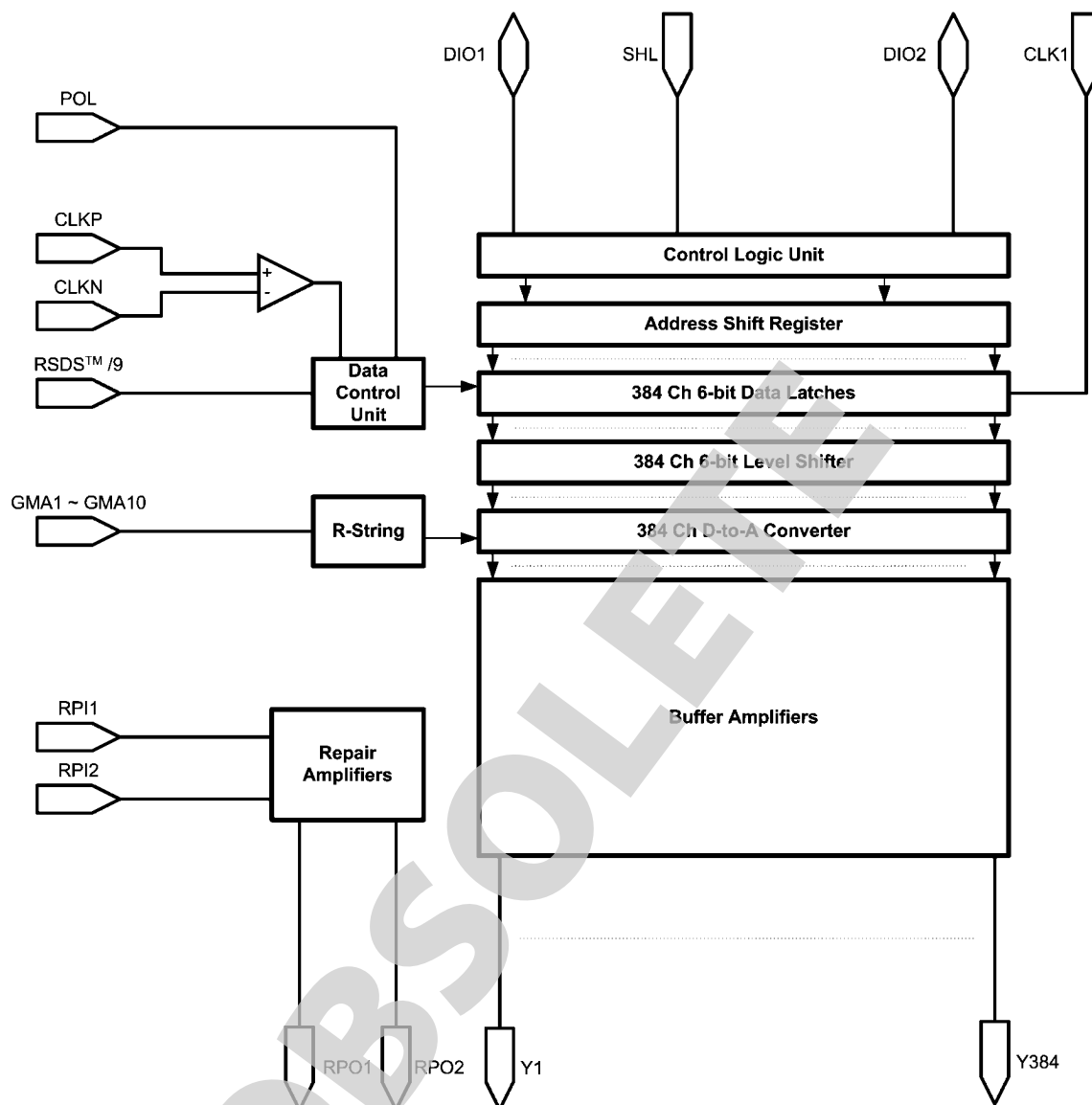

20043206

Functional Description

GENERAL OVERVIEW

The FPD33584 is a low power, low EMI, 384 output column driver with 64 gray level capability (6-bit). It provides direct drive for TFT-LCD displays, eliminating the need for V_{com} modulation. Direct drive significantly reduces system power consumption and also reduces component count while providing superior image quality and cross-talk margin. The FPD33584 utilizes National's *Charge Conservation Technology* that recovers energy stored in the capacitance of the column lines to reduce power consumption further.

The FPD33584 is designed for use in systems using dot inversion as the method of polarity inversion. Column inversion and N-line inversion are also supported. Other modes of polarity inversion including line inversion and frame inversion are not supported.

Digital video data inputs to the FPD33584 are received via a low power, low EMI Reduced Swing Differential Signaling (RSDS) bus. The RSDS digital video commands one of 64 gray level voltages on each output. Output voltages are driven with individual high drive, low offset operational amplifiers. Data loading and line buffering is accomplished by means of an internal, bi-directional shift register.

GAMMA CORRECTION

The FPD33584 is designed to offer compatibility with a wide range of panel gamma characteristics. The output voltage levels corresponding to each of the 64 gray level commands can be externally adjusted to match the desired gamma characteristics of the display by means of two internal resistor-string DACs (RDACs). One RDAC provides the high-polarity output voltages (voltages higher than V_{com}) and the other pro-

vides the low-polarity output voltages (voltages lower than V_{com}).

The FPD33584 is available with several R-DAC resistance curve options, all of which have been carefully designed to accurately match the natural, inverse gamma of a twisted nematic (TN) display with a 2.2 gamma transfer characteristic. Additional, custom gamma curves can be requested through your National Semiconductor representative. A typical TN display, when operated with the FPD33584 drivers will produce a luminance with grayscale characteristic typical of CRT monitors. The resistor values for all R-DACs are shown in [Figure 22](#). The individual R-DAC characteristics can be found in:

- Gamma A— [Figure 4](#), [Figure 5](#), and [Figure 6](#)
- Gamma B— [Figure 7](#), [Figure 8](#), and [Figure 9](#)
- Gamma C— [Figure 10](#), [Figure 11](#), and [Figure 12](#)
- Gamma D— [Figure 13](#), [Figure 14](#), and [Figure 15](#)
- Gamma F— [Figure 16](#), [Figure 17](#), and [Figure 18](#)
- Gamma G— [Figure 19](#), [Figure 20](#), and [Figure 21](#)

Most applications will only need to provide references for each of the two ends of the two R-DACs (GMA1, GMA5, GMA6, and GMA10). Six additional, intermediate R-DAC tap points are available for further customization.

CHARGE CONSERVATION TECHNOLOGY

National Semiconductor's proprietary charge conservation technology significantly reduces power consumption. Charge conservation works by briefly switching all of the columns to a common node at the start of each line. This has the effect of redistributing the charge stored in the capacitance of the panel columns. Because half the columns are at voltages more positive than V_{com} and half are more negative, this redistribution of charge or "charge-sharing" has the effect of pulling all of the columns to a neutral voltage near the middle of the driver's dynamic range. Thus, the voltages on all the columns are driven approximately halfway toward their next value with no power expended. This dramatically reduces panel power dissipation (up to a theoretical limit of 50%) compared to conventional drivers which must drive each column through the entire voltage swing every time polarity is reversed.

'Smart' charge sharing is used to further optimize this feature. Data inversion is monitored and charge shared only across data ranges (when output polarity changes between adjacent lines). This is useful during n-line inversion when polarity changes do not occur at every line transition.

TABLE 1. Charge Sharing Definition

TIME0	TIME1	Charge Share Time
0	0	16 RSDS CLKs (approx. 250ns @ 65MHz)
0	1	32 RSDS CLKs (approx. 500ns @ 65MHz)
1	0	64 RSDS CLKs (approx. 1µs @ 65MHz)
1	1	128 RSDS CLKs (approx. 2µs @ 65MHz)

As shown in [Figure 3](#), charge sharing begins at the falling edge of CLK1 and continues for the number or RSDS clock cycles shown in [Table 1](#). For more information on National's proprietary Smart Charge Sharing technology, please see application note [AN1235 Using Smart Charge Sharing to Reduce Power and Boost Column Driver Performance](#), which is available on the National Semiconductor website or through your National Semiconductor representative.

The amount of charge share time is determined by 2 pins: TIME0 and TIME1. Both TIME0 and TIME1 pins default to a

low state, so if both pins are left floating, the charge share time will be 16 RSDS clock cycles. For most applications, one of the charge share times defined by TIME0 and TIME1 will optimize the performance and power savings in the panel. Generally, the average panel should set charge sharing at either 32 RSDS clocks or 64 RSDS clocks, depending on the data rate and the panel load. Panels with much larger RC loads may need to increase the charge share time to get the maximum benefit and panels with a smaller load can realize power savings with a shorter charge share time. Please contact National Semiconductor if you need further assistance in selecting a charge share time.

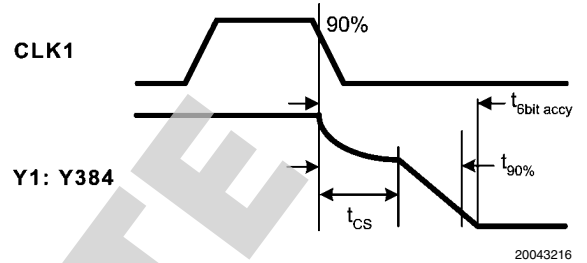

FIGURE 3. FPD33584 Charge Share Timing

RSDS DATA CHANNEL

The RSDS data bus is comprised of nine channels and a common clock. Each channel consists of a two wire differential pair. The nine channels carry digital video data organized as three busses of three channels. Each three channel bus corresponds on one of the three video colors, red, green and blue. The three video busses are comprised of a most, middle and least significant bit. The six bit video word is carried on the three wires of each video bus in two consecutive half words. The even fields of the word are transmitted-received on a first clock and are followed by the odd fields on the following clock transition. Clocking is dual edge and the clock signal is also carried on a two wire, differential pair.

OPTIONAL REPAIR AMPLIFIERS

The FPD33584 provides two general purpose, unity gain output buffers, one located at each end of the input bank of the die. These buffers may be used to repair an open in a column line. The drive signal from the output of the faulted line can be stitched to the input of the repair buffer during the repair process. The output of the repair buffer is then routed to the other side of the column line making it possible to maintain fast rise and fall times on both ends of the afflicted column line.

PIN DESCRIPTIONS

The pin order configuration for the FPD33584 is shown in [Figure 23](#)

CLKP and CLKN—Data Clock (input)

Differential clock input for RSDS data loading.

D00P–D22N—RSDS Data Bus (input)

D0xP–D0xN—Data for OUTPUTS 1,4,7...382 (red)

D1xP–D1xN—Data for OUTPUTS 2,5,8...383 (green)

D2xP–D2xN—Data for OUTPUTS 3,6,9...384 (blue)

Where x = 0 (LSB), 1 or 2 (MSB).

CLK1—Data Load (input)

The rising edge of CLK1 copies the digital video buffered by the shift register into a second latch for conversion to analog. The falling edge of CLK1 begins charge sharing.

POL—Polarity (input)

When POL is low, odd numbered outputs (1, 3, 5, . . . 383) are controlled by VGMA6 through VGMA10 and even numbered outputs are controlled by VGMA1 through VGMA5. When POL is high, odd numbered outputs are controlled by VGMA1 through VGMA5 and even numbered outputs are controlled by VGMA6 through VGMA10. The POL signal for line #n is sampled at the rising edge of CLK1 on line #n-1.

DIO1/DIO2—Data Loading Enable 1 and 2 (I/O)

The DIO1 and DIO2 pins allow several FPD33584 column drivers to be daisy chained together. The start pulse (SP or STH) from the timing controller is connected to the input DIOx pin on the first column driver in the chain. The input DIO for the remaining column drivers in the chain are connected to the output DIO from the preceding column driver. The SHL pin controls whether DIO1 or DIO2 is configured as the input. If SHL is high, then the DIO1 pin is configured as an input and the DIO2 pin as an output. If SHL is low, the DIO2 pin is configured as an input and the DIO1 pin as an output.

The input DIOx pulse is latched on the falling edge of CLKP

DATPOL—Digital Data Invert (input)

When DATPOL is high, RSDS data is inverted. The DATPOL pin can be tied either high or low through connection to a neighboring pin on a custom package eliminating the need to connect the pin to the PCB.

SHL—Data Shift Direction (input)

The SHL pin controls the data load direction. When SHL is high, the data is loaded from output 1 to output 384, DIO1 is configured as an input, and DIO2 is configured as an output. When SHL is low, the data is loaded from output 384 to output 1, DIO2 is configured as an input, and DIO1 is configured as an output. The SHL pin can be tied off in the custom package, eliminating the need to connect it to the PCB.

RPI1/ RPI2—Repair Amp Input 1 and 2 (input)

The input signal for the repair line buffers. These buffers are optional and when not used, the input should be tied to ground. RPI1 and RPI2 can be tied to ground with a connection in the package, eliminating the need to connect them to the PCB.

RPO1/ RPO2—Repair Amp Output 1 and 2 (output)

The output of the repair line buffers. These outputs are current buffered copies of their respective inputs. When not in use, RPO1 and RPO2 can be left unconnected.

TIME0/ TIME1—Charge Share Time Select Pins (input)

The TIME0 and TIME1 pins define the length of charge share time. [Table 1](#) lists the charge share time options defined by TIME0 and TIME1. Both of these pins have internal pull-down resistors and default to a logic low state. They can also be tied high in the package, eliminating the need to connect them to the PCB.

V_{GMA1}–V_{GMA10}—FDAC References (input)

The reference voltages to the upper and lower RDACs used to control the inverse gamma transfer function of the driver.

Option - Any or all of the inputs V_{GMA2} through V_{GMA4} and V_{GMA7} through V_{GMA9} can be left undriven (floating).

V_{DD1}—Digital Voltage Supply (power)

Positive supply voltage for the digital logic functions of the driver. Nominally 3.3V.

V_{DD2}—Analog Voltage Supply (power)

Positive supply voltage for the analog functions of the driver. Nominally between 8.0 and 10.0V

V_{SS1}—Digital Ground (power)

Digital ground reference voltage. Typically tied to V_{SS2} on the PCB.

V_{SS2}—Analog Ground (power)

Analog ground reference voltage. Typically tied to V_{SS1} on the PCB

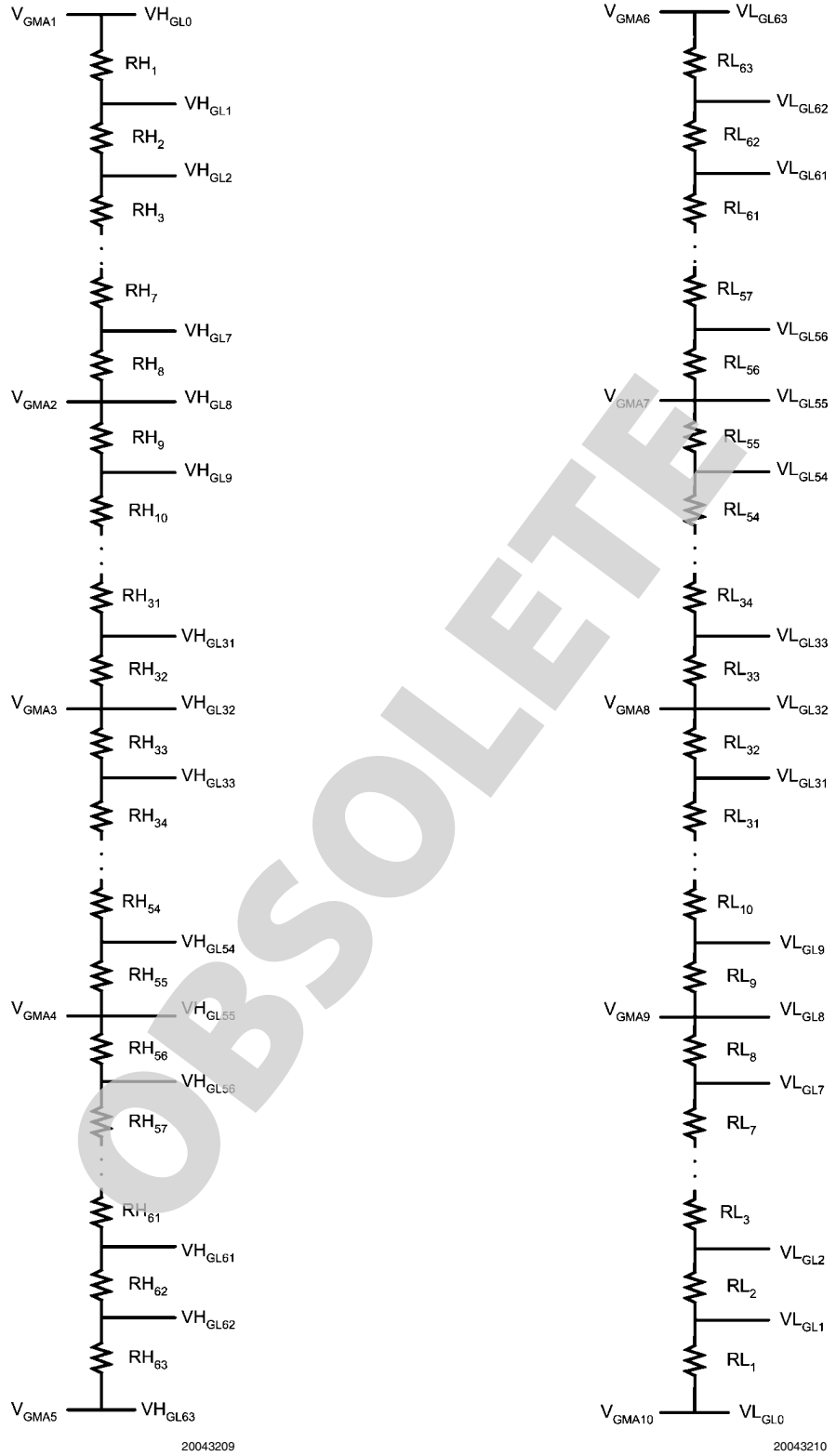

FIGURE 4. FPD33584A R-DAC Configuration

Data	Output Voltage (gamma A)			Data	Output Voltage (gamma A)		
00 _H	VL0	VGMA10		20 _H	VL32	VGMA8	
01 _H	VL1	VGMA9-(VGMA9-VGMA10)x	4049/5879	21 _H	VL33	VGMA7-(VGMA7-VGMA8)x	2588/2692
02 _H	VL2	VGMA9-(VGMA9-VGMA10)x	3022/5879	22 _H	VL34	VGMA7-(VGMA7-VGMA8)x	2484/2692
03 _H	VL3	VGMA9-(VGMA9-VGMA10)x	2293/5879	23 _H	VL35	VGMA7-(VGMA7-VGMA8)x	2380/2692
04 _H	VL4	VGMA9-(VGMA9-VGMA10)x	1668/5879	24 _H	VL36	VGMA7-(VGMA7-VGMA8)x	2276/2692
05 _H	VL5	VGMA9-(VGMA9-VGMA10)x	1147/5879	25 _H	VL37	VGMA7-(VGMA7-VGMA8)x	2172/2692
06 _H	VL6	VGMA9-(VGMA9-VGMA10)x	730/5879	26 _H	VL38	VGMA7-(VGMA7-VGMA8)x	2068/2692
07 _H	VL7	VGMA9-(VGMA9-VGMA10)x	313/5879	27 _H	VL39	VGMA7-(VGMA7-VGMA8)x	1964/2692
08 _H	VL8	GMA9		28 _H	VL40	VGMA7-(VGMA7-VGMA8)x	1860/2692
09 _H	VL9	VGMA8-(VGMA8-VGMA9)x	2825/3138	29 _H	VL41	VGMA7-(VGMA7-VGMA8)x	1756/2692
0A _H	VL10	VGMA8-(VGMA8-VGMA9)x	2617/3138	2A _H	VL42	VGMA7-(VGMA7-VGMA8)x	1652/2692
0B _H	VL11	VGMA8-(VGMA8-VGMA9)x	2409/3138	2B _H	VL43	VGMA7-(VGMA7-VGMA8)x	1548/2692
0C _H	VL12	VGMA8-(VGMA8-VGMA9)x	2260/3138	2C _H	VL44	VGMA7-(VGMA7-VGMA8)x	1429/2692
0D _H	VL13	VGMA8-(VGMA8-VGMA9)x	2111/3138	2D _H	VL45	VGMA7-(VGMA7-VGMA8)x	1310/2692
0E _H	VL14	VGMA8-(VGMA8-VGMA9)x	1977/3138	2E _H	VL46	VGMA7-(VGMA7-VGMA8)x	1191/2692
0F _H	VL15	VGMA8-(VGMA8-VGMA9)x	1843/3138	2F _H	VL47	VGMA7-(VGMA7-VGMA8)x	1072/2692
10 _H	VL16	VGMA8-(VGMA8-VGMA9)x	1724/3138	30 _H	VL48	VGMA7-(VGMA7-VGMA8)x	953/2692
11 _H	VL17	VGMA8-(VGMA8-VGMA9)x	1605/3138	31 _H	VL49	VGMA7-(VGMA7-VGMA8)x	834/2692
12 _H	VL18	VGMA8-(VGMA8-VGMA9)x	1486/3138	32 _H	VL50	VGMA7-(VGMA7-VGMA8)x	715/2692
13 _H	VL19	VGMA8-(VGMA8-VGMA9)x	1367/3138	33 _H	VL51	VGMA7-(VGMA7-VGMA8)x	581/2692
14 _H	VL20	VGMA8-(VGMA8-VGMA9)x	1248/3138	34 _H	VL52	VGMA7-(VGMA7-VGMA8)x	447/2692
15 _H	VL21	VGMA8-(VGMA8-VGMA9)x	1144/3138	35 _H	VL53	VGMA7-(VGMA7-VGMA8)x	298/2692
16 _H	VL22	VGMA8-(VGMA8-VGMA9)x	1040/3138	36 _H	VL54	VGMA7-(VGMA7-VGMA8)x	149/2692
17 _H	VL23	VGMA8-(VGMA8-VGMA9)x	936/3138	37 _H	VL55	VGMA7	
18 _H	VL24	VGMA8-(VGMA8-VGMA9)x	832/3138	38 _H	VL56	VGMA6-(VGMA6-VGMA7)x	3140/3289
19 _H	VL25	VGMA8-(VGMA8-VGMA9)x	728/3138	39 _H	VL57	VGMA6-(VGMA6-VGMA7)x	2947/3289
1A _H	VL26	VGMA8-(VGMA8-VGMA9)x	624/3138	3A _H	VL58	VGMA6-(VGMA6-VGMA7)x	2724/3289
1B _H	VL27	VGMA8-(VGMA8-VGMA9)x	520/3138	3B _H	VL59	VGMA6-(VGMA6-VGMA7)x	2471/3289
1C _H	VL28	VGMA8-(VGMA8-VGMA9)x	416/3138	3C _H	VL60	VGMA6-(VGMA6-VGMA7)x	2158/3289
1D _H	VL29	VGMA8-(VGMA8-VGMA9)x	312/3138	3D _H	VL61	VGMA6-(VGMA6-VGMA7)x	1637/3289
1E _H	VL30	VGMA8-(VGMA8-VGMA9)x	208/3138	3E _H	VL62	VGMA6-(VGMA6-VGMA7)x	923/3289
1F _H	VL31	VGMA8-(VGMA8-VGMA9)x	104/3138	3F _H	VL63	VGMA6	

FIGURE 5. FPD33584A Lower Gamma Voltages

Data Output Voltage (gamma A)				Data Output Voltage (gamma A)			
00 _H	VH0	VGMA1		20 _H	VH32	VGMA3	
01 _H	VH1	VGMA2+(VGMA1-VGMA2)x	4049/5879	21 _H	VH33	VGMA4+(VGMA3-VGMA4)x	2588/2692
02 _H	VH2	VGMA2+(VGMA1-VGMA2)x	3022/5879	22 _H	VH34	VGMA4+(VGMA3-VGMA4)x	2484/2692
03 _H	VH3	VGMA2+(VGMA1-VGMA2)x	2293/5879	23 _H	VH35	VGMA4+(VGMA3-VGMA4)x	2380/2692
04 _H	VH4	VGMA2+(VGMA1-VGMA2)x	1668/5879	24 _H	VH36	VGMA4+(VGMA3-VGMA4)x	2276/2692
05 _H	VH5	VGMA2+(VGMA1-VGMA2)x	1147/5879	25 _H	VH37	VGMA4+(VGMA3-VGMA4)x	2172/2692
06 _H	VH6	VGMA2+(VGMA1-VGMA2)x	730/5879	26 _H	VH38	VGMA4+(VGMA3-VGMA4)x	2068/2692
07 _H	VH7	VGMA2+(VGMA1-VGMA2)x	313/5879	27 _H	VH39	VGMA4+(VGMA3-VGMA4)x	1964/2692
08 _H	VH8	GMA2		28 _H	VH40	VGMA4+(VGMA3-VGMA4)x	1860/2692
09 _H	VH9	VGMA3+(VGMA2-VGMA3)x	2825/3138	29 _H	VH41	VGMA4+(VGMA3-VGMA4)x	1756/2692
0A _H	VH10	VGMA3+(VGMA2-VGMA3)x	2617/3138	2A _H	VH42	VGMA4+(VGMA3-VGMA4)x	1652/2692
0B _H	VH11	VGMA3+(VGMA2-VGMA3)x	2409/3138	2B _H	VH43	VGMA4+(VGMA3-VGMA4)x	1548/2692
0C _H	VH12	VGMA3+(VGMA2-VGMA3)x	2260/3138	2C _H	VH44	VGMA4+(VGMA3-VGMA4)x	1429/2692
0D _H	VH13	VGMA3+(VGMA2-VGMA3)x	2111/3138	2D _H	VH45	VGMA4+(VGMA3-VGMA4)x	1310/2692
0E _H	VH14	VGMA3+(VGMA2-VGMA3)x	1977/3138	2E _H	VH46	VGMA4+(VGMA3-VGMA4)x	1191/2692
0F _H	VH15	VGMA3+(VGMA2-VGMA3)x	1843/3138	2F _H	VH47	VGMA4+(VGMA3-VGMA4)x	1072/2692
10 _H	VH16	VGMA3+(VGMA2-VGMA3)x	1724/3138	30 _H	VH48	VGMA4+(VGMA3-VGMA4)x	953/2692
11 _H	VH17	VGMA3+(VGMA2-VGMA3)x	1605/3138	31 _H	VH49	VGMA4+(VGMA3-VGMA4)x	834/2692
12 _H	VH18	VGMA3+(VGMA2-VGMA3)x	1486/3138	32 _H	VH50	VGMA4+(VGMA3-VGMA4)x	715/2692
13 _H	VH19	VGMA3+(VGMA2-VGMA3)x	1367/3138	33 _H	VH51	VGMA4+(VGMA3-VGMA4)x	581/2692
14 _H	VH20	VGMA3+(VGMA2-VGMA3)x	1248/3138	34 _H	VH52	VGMA4+(VGMA3-VGMA4)x	447/2692
15 _H	VH21	VGMA3+(VGMA2-VGMA3)x	1144/3138	35 _H	VH53	VGMA4+(VGMA3-VGMA4)x	298/2692
16 _H	VH22	VGMA3+(VGMA2-VGMA3)x	1040/3138	36 _H	VH54	VGMA4+(VGMA3-VGMA4)x	149/2692
17 _H	VH23	VGMA3+(VGMA2-VGMA3)x	936/3138	37 _H	VH55	VGMA4	
18 _H	VH24	VGMA3+(VGMA2-VGMA3)x	832/3138	38 _H	VH56	VGMA5+(VGMA4-VGMA5)x	3140/3289
19 _H	VH25	VGMA3+(VGMA2-VGMA3)x	728/3138	39 _H	VH57	VGMA5+(VGMA4-VGMA5)x	2947/3289
1A _H	VH26	VGMA3+(VGMA2-VGMA3)x	624/3138	3A _H	VH58	VGMA5+(VGMA4-VGMA5)x	2724/3289
1B _H	VH27	VGMA3+(VGMA2-VGMA3)x	520/3138	3B _H	VH59	VGMA5+(VGMA4-VGMA5)x	2471/3289
1C _H	VH28	VGMA3+(VGMA2-VGMA3)x	416/3138	3C _H	VH60	VGMA5+(VGMA4-VGMA5)x	2158/3289
1D _H	VH29	VGMA3+(VGMA2-VGMA3)x	312/3138	3D _H	VH61	VGMA5+(VGMA4-VGMA5)x	1637/3289
1E _H	VH30	VGMA3+(VGMA2-VGMA3)x	208/3138	3E _H	VH62	VGMA5+(VGMA4-VGMA5)x	923/3289
1F _H	VH31	VGMA3+(VGMA2-VGMA3)x	104/3138	3F _H	VH63	VGMA5	

FIGURE 6. FPD33584A Upper Gamma Voltages

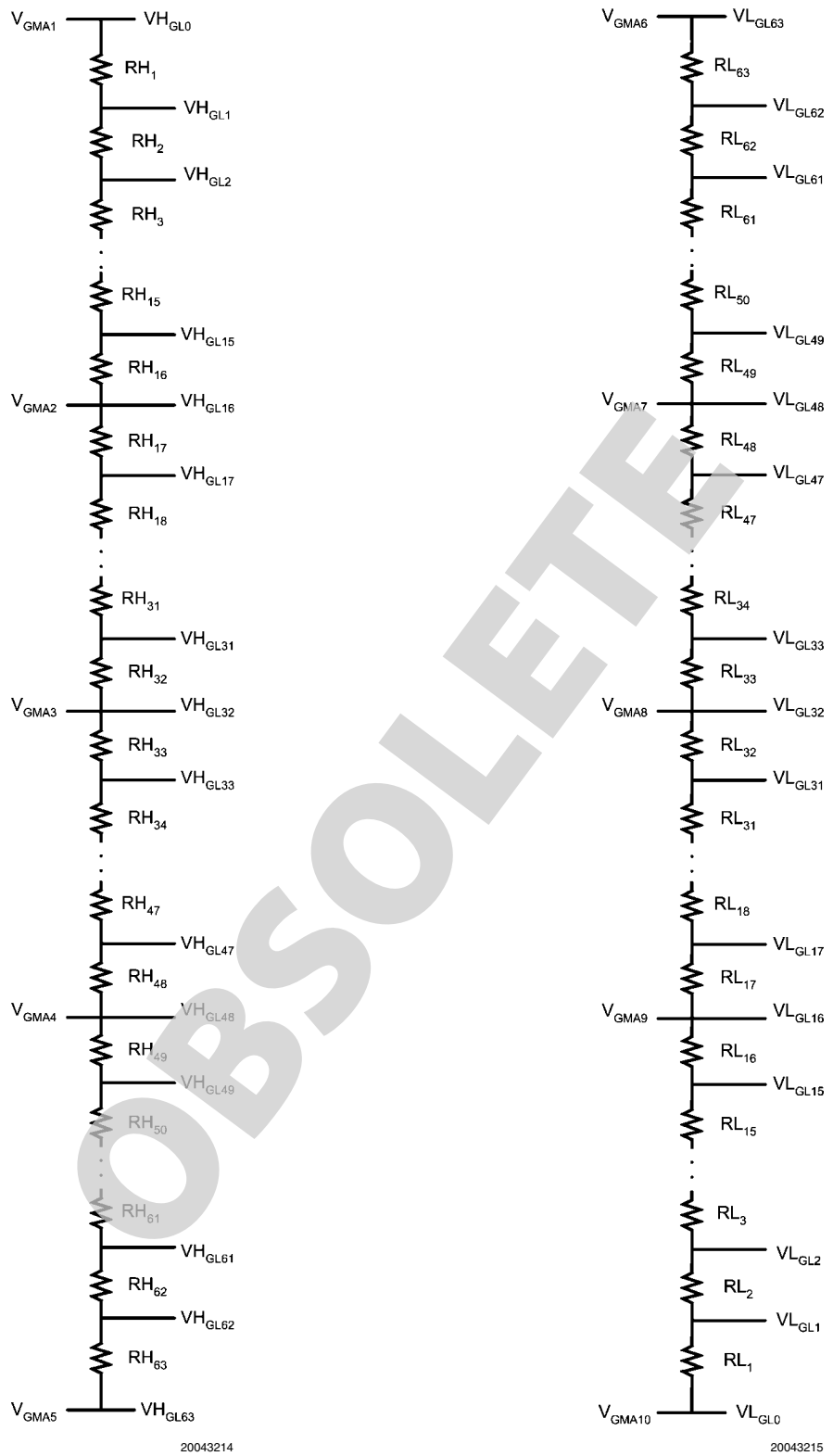

FIGURE 7. FPD33584B R-DAC Configuration

Data	Output Voltage (gamma B)			Data	Output Voltage (gamma B)		
00 _H	VL0	VGMA10		20 _H	VL32	VGMA8	
01 _H	VL1	VGMA9-(VGMA9-VGMA10)×	5747/6149	21 _H	VL33	VGMA7-(VGMA7-VGMA8)×	2040/2174
02 _H	VL2	VGMA9-(VGMA9-VGMA10)×	5345/6149	22 _H	VL34	VGMA7-(VGMA7-VGMA8)×	1906/2174
03 _H	VL3	VGMA9-(VGMA9-VGMA10)×	4943/6149	23 _H	VL35	VGMA7-(VGMA7-VGMA8)×	1772/2174
04 _H	VL4	VGMA9-(VGMA9-VGMA10)×	4541/6149	24 _H	VL36	VGMA7-(VGMA7-VGMA8)×	1638/2174
05 _H	VL5	VGMA9-(VGMA9-VGMA10)×	4139/6149	25 _H	VL37	VGMA7-(VGMA7-VGMA8)×	1504/2174
06 _H	VL6	VGMA9-(VGMA9-VGMA10)×	3737/6149	26 _H	VL38	VGMA7-(VGMA7-VGMA8)×	1370/2174
07 _H	VL7	VGMA9-(VGMA9-VGMA10)×	3335/6149	27 _H	VL39	VGMA7-(VGMA7-VGMA8)×	1236/2174
08 _H	VL8	VGMA9-(VGMA9-VGMA10)×	2933/6149	28 _H	VL40	VGMA7-(VGMA7-VGMA8)×	1102/2174
09 _H	VL9	VGMA9-(VGMA9-VGMA10)×	2531/6149	29 _H	VL41	VGMA7-(VGMA7-VGMA8)×	968/2174
0A _H	VL10	VGMA9-(VGMA9-VGMA10)×	2129/6149	2A _H	VL42	VGMA7-(VGMA7-VGMA8)×	834/2174
0B _H	VL11	VGMA9-(VGMA9-VGMA10)×	1727/6149	2B _H	VL43	VGMA7-(VGMA7-VGMA8)×	700/2174
0C _H	VL12	VGMA9-(VGMA9-VGMA10)×	1325/6149	2C _H	VL44	VGMA7-(VGMA7-VGMA8)×	566/2174
0D _H	VL13	VGMA9-(VGMA9-VGMA10)×	923/6149	2D _H	VL45	VGMA7-(VGMA7-VGMA8)×	432/2174
0E _H	VL14	VGMA9-(VGMA9-VGMA10)×	611/6149	2E _H	VL46	VGMA7-(VGMA7-VGMA8)×	298/2174
0F _H	VL15	VGMA9-(VGMA9-VGMA10)×	298/6149	2F _H	VL47	VGMA7-(VGMA7-VGMA8)×	149/2174
10 _H	VL16	VGMA9		30 _H	VL48	VGMA7	
11 _H	VL17	VGMA8-(VGMA8-VGMA9)×	3036/3304	31 _H	VL49	VGMA6-(VGMA6-VGMA7)×	3214/3378
12 _H	VL18	VGMA8-(VGMA8-VGMA9)×	2768/3304	32 _H	VL50	VGMA6-(VGMA6-VGMA7)×	3035/3378
13 _H	VL19	VGMA8-(VGMA8-VGMA9)×	2500/3304	33 _H	VL51	VGMA6-(VGMA6-VGMA7)×	2856/3378
14 _H	VL20	VGMA8-(VGMA8-VGMA9)×	2247/3304	34 _H	VL52	VGMA6-(VGMA6-VGMA7)×	2663/3378
15 _H	VL21	VGMA8-(VGMA8-VGMA9)×	2009/3304	35 _H	VL53	VGMA6-(VGMA6-VGMA7)×	2470/3378
16 _H	VL22	VGMA8-(VGMA8-VGMA9)×	1786/3304	36 _H	VL54	VGMA6-(VGMA6-VGMA7)×	2262/3378
17 _H	VL23	VGMA8-(VGMA8-VGMA9)×	1578/3304	37 _H	VL55	VGMA6-(VGMA6-VGMA7)×	2054/3378
18 _H	VL24	VGMA8-(VGMA8-VGMA9)×	1177/3304	38 _H	VL56	VGMA6-(VGMA6-VGMA7)×	1816/3378
19 _H	VL25	VGMA8-(VGMA8-VGMA9)×	984/3304	39 _H	VL57	VGMA6-(VGMA6-VGMA7)×	1578/3378
1A _H	VL26	VGMA8-(VGMA8-VGMA9)×	805/3304	3A _H	VL58	VGMA6-(VGMA6-VGMA7)×	1325/3378
1B _H	VL27	VGMA8-(VGMA8-VGMA9)×	626/3304	3B _H	VL59	VGMA6-(VGMA6-VGMA7)×	1072/3378
1C _H	VL28	VGMA8-(VGMA8-VGMA9)×	462/3304	3C _H	VL60	VGMA6-(VGMA6-VGMA7)×	804/3378
1D _H 1D _H	VL29	VGMA8-(VGMA8-VGMA9)×	462/3304	3D _H	VL61	VGMA6-(VGMA6-VGMA7)×	536/3378
1E _H	VL30	VGMA8-(VGMA8-VGMA9)×	298/3304	3E _H 3E _H	VL62	VGMA6-(VGMA6-VGMA7)×	268/3378
1F _H	VL31	VGMA8-(VGMA8-VGMA9)×	149/3304	3F _H	VL63	VGMA6	

FIGURE 8. FPD33584B Lower Gamma Voltages (compatible with Samsung S6C0666)

Data	Output Voltage (gamma B)			Data	Output Voltage (gamma B)		
00 _H	VH0	VGMA1		20 _H	VH32	VGMA3	
01 _H	VH1	VGMA2+(VGMA1-VGMA2)×	5747/6149	21 _H	VH33	VGMA4+(VGMA3-VGMA4)×	2040/2174
02 _H	VH2	VGMA2+(VGMA1-VGMA2)×	5345/6149	22 _H	VH34	VGMA4+(VGMA3-VGMA4)×	1906/2174
03 _H	VH3	VGMA2+(VGMA1-VGMA2)×	4943/6149	23 _H	VH35	VGMA4+(VGMA3-VGMA4)×	1772/2174
04 _H	VH4	VGMA2+(VGMA1-VGMA2)×	4541/6149	24 _H	VH36	VGMA4+(VGMA3-VGMA4)×	1638/2174
05 _H	VH5	VGMA2+(VGMA1-VGMA2)×	4139/6149	25 _H	VH37	VGMA4+(VGMA3-VGMA4)×	1504/2174
06 _H	VH6	VGMA2+(VGMA1-VGMA2)×	3737/6149	26 _H	VH38	VGMA4+(VGMA3-VGMA4)×	1370/2174
07 _H	VH7	VGMA2+(VGMA1-VGMA2)×	3335/6149	27 _H	VH39	VGMA4+(VGMA3-VGMA4)×	1236/2174
08 _H	VH8	VGMA2+(VGMA1-VGMA2)×	2933/6149	28 _H	VH40	VGMA4+(VGMA3-VGMA4)×	1102/2174
09 _H	VH9	VGMA2+(VGMA1-VGMA2)×	2531/6149	29 _H	VH41	VGMA4+(VGMA3-VGMA4)×	968/2174
0A _H	VH10	VGMA2+(VGMA1-VGMA2)×	2129/6149	2A _H	VH42	VGMA4+(VGMA3-VGMA4)×	834/2174
0B _H	VH11	VGMA2+(VGMA1-VGMA2)×	1727/6149	2B _H	VH43	VGMA4+(VGMA3-VGMA4)×	700/2174
0C _H	VH12	VGMA2+(VGMA1-VGMA2)×	1325/6149	2C _H	VH44	VGMA4+(VGMA3-VGMA4)×	566/2174
0D _H	VH13	VGMA2+(VGMA1-VGMA2)×	968/6149	2D _H	VH45	VGMA4+(VGMA3-VGMA4)×	432/2174
0E _H	VH14	VGMA2+(VGMA1-VGMA2)×	611/6149	2E _H	VH46	VGMA4+(VGMA3-VGMA4)×	298/2174
0F _H	VH15	VGMA2+(VGMA1-VGMA2)×	298/6149	2F _H	VH47	VGMA4+(VGMA3-VGMA4)×	149/2174
10 _H	VH16	VGMA2		30 _H	VH48	VGMA4	
11 _H	VH17	VGMA3+(VGMA2-VGMA3)×	3036/3304	31 _H	VH49	VGMA5+(VGMA4-VGMA5)×	3214/3378
12 _H	VH18	VGMA3+(VGMA2-VGMA3)×	2768/3304	32 _H	VH50	VGMA5+(VGMA4-VGMA5)×	3035/3378
13 _H	VH19	VGMA3+(VGMA2-VGMA3)×	2500/3304	33 _H	VH51	VGMA5+(VGMA4-VGMA5)×	2856/3378
14 _H	VH20	VGMA3+(VGMA2-VGMA3)×	2247/3304	34 _H	VH52	VGMA5+(VGMA4-VGMA5)×	2663/3378
15 _H	VH21	VGMA3+(VGMA2-VGMA3)×	2009/3304	35 _H	VH53	VGMA5+(VGMA4-VGMA5)×	2470/3378
16 _H	VH22	VGMA3+(VGMA2-VGMA3)×	1786/3304	36 _H	VH54	VGMA5+(VGMA4-VGMA5)×	2262/3378
17 _H	VH23	VGMA3+(VGMA2-VGMA3)×	1578/3304	37 _H	VH55	VGMA5+(VGMA4-VGMA5)×	2054/3378
18 _H	VH24	VGMA3+(VGMA2-VGMA3)×	1177/3304	38 _H	VH56	VGMA5+(VGMA4-VGMA5)×	1816/3378
19 _H	VH25	VGMA3+(VGMA2-VGMA3)×	984/3304	39 _H	VH57	VGMA5+(VGMA4-VGMA5)×	1578/3378
1A _H	VH26	VGMA3+(VGMA2-VGMA3)×	805/3304	3A _H	VH58	VGMA5+(VGMA4-VGMA5)×	1325/3378
1B _H	VH27	VGMA3+(VGMA2-VGMA3)×	626/3304	3B _H	VH59	VGMA5+(VGMA4-VGMA5)×	1072/3378
1C _H	VH28	VGMA3+(VGMA2-VGMA3)×	462/3304	3C _H	VH60	VGMA5+(VGMA4-VGMA5)×	804/3378
1D _H	VH29	VGMA3+(VGMA2-VGMA3)×	462/3304	3D _H	VH61	VGMA5+(VGMA4-VGMA5)×	536/3378
1E _H	VH30	VGMA3+(VGMA2-VGMA3)×	298/3304	3E _H	VH62	VGMA5+(VGMA4-VGMA5)×	268/3378
1F _H	VH31	VGMA3+(VGMA2-VGMA3)×	149/3304	3F _H	VH63	VGMA5	

FIGURE 9. FPD33584B Upper Gamma Voltages (compatible with Samsung S6C0666)

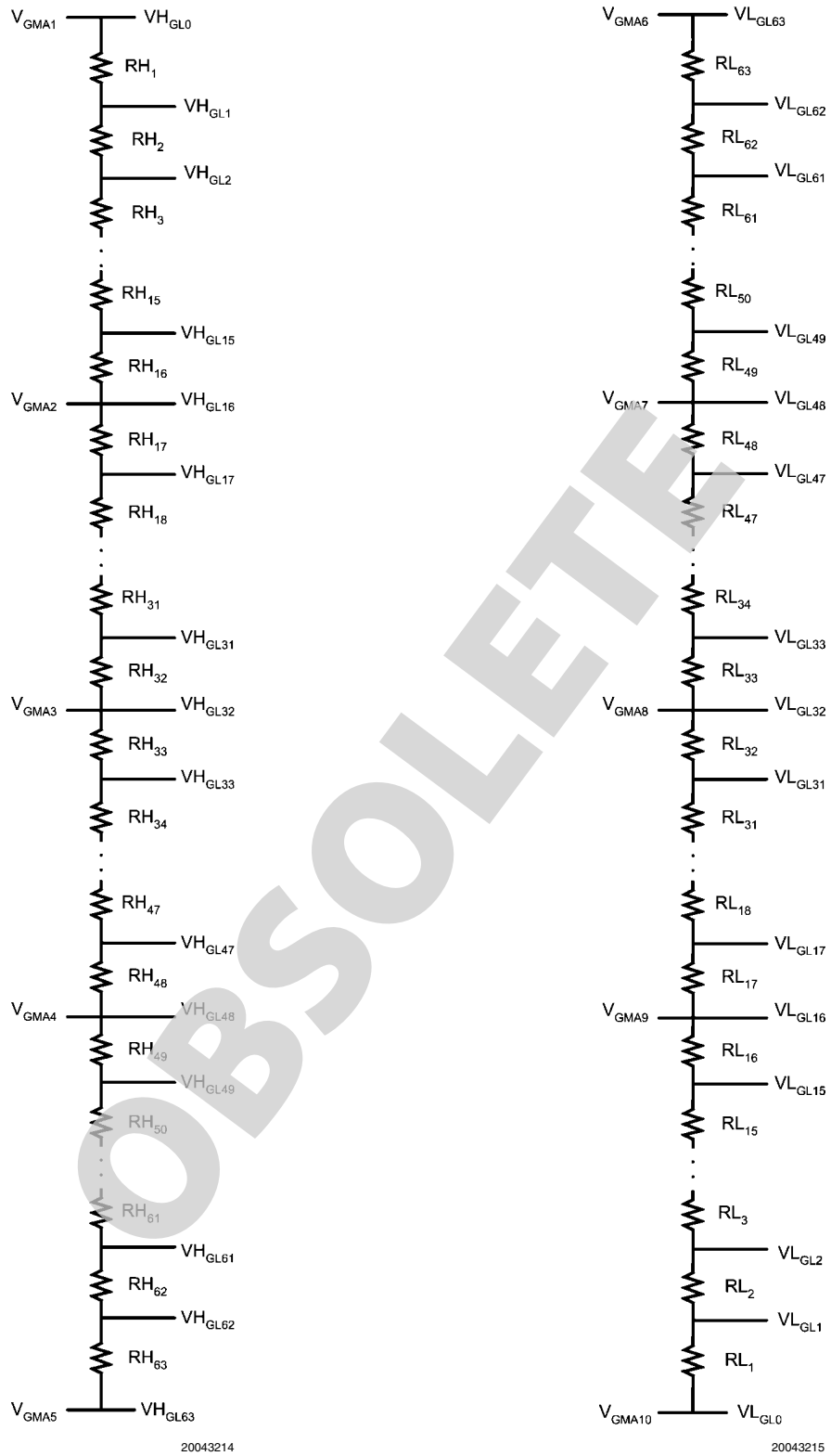

FIGURE 10. FPD33584C R-DAC Configuration

Data	Output Voltage (gamma C)			Data	Output Voltage (gamma C)		
00 _H	VL0	VGMA10		20 _H	VL32	VGMA8	
01 _H	VL1	VGMA9-(VGMA9-VGMA10)x	7250/8050	21 _H	VL33	VGMA7-(VGMA7-VGMA8)x	1500/1600
02 _H	VL2	VGMA9-(VGMA9-VGMA10)x	6500/8050	22 _H	VL34	VGMA7-(VGMA7-VGMA8)x	1400/1600
03 _H	VL3	VGMA9-(VGMA9-VGMA10)x	5800/8050	23 _H	VL35	VGMA7-(VGMA7-VGMA8)x	1300/1600
04 _H	VL4	VGMA9-(VGMA9-VGMA10)x	5150/8050	24 _H	VL36	VGMA7-(VGMA7-VGMA8)x	1200/1600
05 _H	VL5	VGMA9-(VGMA9-VGMA10)x	4550/8050	25 _H	VL37	VGMA7-(VGMA7-VGMA8)x	1100/1600
06 _H	VL6	VGMA9-(VGMA9-VGMA10)x	4000/8050	26 _H	VL38	VGMA7-(VGMA7-VGMA8)x	1000/1600
07 _H	VL7	VGMA9-(VGMA9-VGMA10)x	3450/8050	27 _H	VL39	VGMA7-(VGMA7-VGMA8)x	900/1600
08 _H	VL8	VGMA9-(VGMA9-VGMA10)x	2950/8050	28 _H	VL40	VGMA7-(VGMA7-VGMA8)x	800/1600
09 _H	VL9	VGMA9-(VGMA9-VGMA10)x	2450/8050	29 _H	VL41	VGMA7-(VGMA7-VGMA8)x	700/1600
0A _H	VL10	VGMA9-(VGMA9-VGMA10)x	2050/8050	2A _H	VL42	VGMA7-(VGMA7-VGMA8)x	600/1600
0B _H	VL11	VGMA9-(VGMA9-VGMA10)x	1650/8050	2B _H	VL43	VGMA7-(VGMA7-VGMA8)x	500/1600
0C _H	VL12	VGMA9-(VGMA9-VGMA10)x	1300/8050	2C _H	VL44	VGMA7-(VGMA7-VGMA8)x	400/1600
0D _H	VL13	VGMA9-(VGMA9-VGMA10)x	950/8050	2D _H	VL45	VGMA7-(VGMA7-VGMA8)x	300/1600
0E _H	VL14	VGMA9-(VGMA9-VGMA10)x	600/8050	2E _H	VL46	VGMA7-(VGMA7-VGMA8)x	200/1600
0F _H	VL15	VGMA9-(VGMA9-VGMA10)x	300/8050	2F _H	VL47	VGMA7-(VGMA7-VGMA8)x	100/1600
10 _H	VL16	VGMA9		30 _H	VL48	VGMA7	
11 _H	VL17	VGMA8-(VGMA8-VGMA9)x	2450/2750	31 _H	VL49	VGMA6-(VGMA6-VGMA7)x	3350/3450
12 _H	VL18	VGMA8-(VGMA8-VGMA9)x	2200/2750	32 _H	VL50	VGMA6-(VGMA6-VGMA7)x	3250/3450
13 _H	VL19	VGMA8-(VGMA8-VGMA9)x	1950/2750	33 _H	VL51	VGMA6-(VGMA6-VGMA7)x	3150/3450
14 _H	VL20	VGMA8-(VGMA8-VGMA9)x	1700/2750	34 _H	VL52	VGMA6-(VGMA6-VGMA7)x	3050/3450
15 _H	VL21	VGMA8-(VGMA8-VGMA9)x	1500/2750	35 _H	VL53	VGMA6-(VGMA6-VGMA7)x	2950/3450
16 _H	VL22	VGMA8-(VGMA8-VGMA9)x	1300/2750	36 _H	VL54	VGMA6-(VGMA6-VGMA7)x	2800/3450
17 _H	VL23	VGMA8-(VGMA8-VGMA9)x	1100/2750	37 _H	VL55	VGMA6-(VGMA6-VGMA7)x	2650/3450
18 _H	VL24	VGMA8-(VGMA8-VGMA9)x	950/2750	38 _H 38 _H	VL56	VGMA6-(VGMA6-VGMA7)x	2500/3450
19 _H 19 _H	VL25	VGMA8-(VGMA8-VGMA9)x	800/2750	39 _H	VL57	VGMA6-(VGMA6-VGMA7)x	2300/3450
1A _H	VL26	VGMA8-(VGMA8-VGMA9)x	650/2750	3A _H	VL58	VGMA6-(VGMA6-VGMA7)x	2100/3450
1B _H	VL27	VGMA8-(VGMA8-VGMA9)x	500/2750	3B _H	VL59	VGMA6-(VGMA6-VGMA7)x	1850/3450
1C _H	VL28	VGMA8-(VGMA8-VGMA9)x	400/2750	3C _H	VL60	VGMA6-(VGMA6-VGMA7)x	1600/3450
1D _H	VL29	VGMA8-(VGMA8-VGMA9)x	300/2750	3D _H	VL61	VGMA6-(VGMA6-VGMA7)x	1300/3450
1E _H	VL30	VGMA8-(VGMA8-VGMA9)x	200/2750	3E _H	VL62	VGMA6-(VGMA6-VGMA7)x	800/3450
1F _H	VL31	VGMA8-(VGMA8-VGMA9)x	100/2750	3F _H	VL63	VGMA6	

FIGURE 11. FPD33584C Lower Gamma Voltages (compatible with NEC μ PD17632A)

Data	Output Voltage (gamma C)			Data	Output Voltage (gamma C)		
00 _H	VH0	VGMA1		20 _H	VH32	VGMA3	
01 _H	VH1	VGMA2+(VGMA1-VGMA2)x	7250/8050	21 _H	VH33	VGMA4+(VGMA3-VGMA4)x	1500/1600
02 _H	VH2	VGMA2+(VGMA1-VGMA2)x	6500/8050	22 _H	VH34	VGMA4+(VGMA3-VGMA4)x	1400/1600
03 _H	VH3	VGMA2+(VGMA1-VGMA2)x	5800/8050	23 _H	VH35	VGMA4+(VGMA3-VGMA4)x	1300/1600
04 _H	VH4	VGMA2+(VGMA1-VGMA2)x	5150/8050	24 _H	VH36	VGMA4+(VGMA3-VGMA4)x	1200/1600
05 _H	VH5	VGMA2+(VGMA1-VGMA2)x	4550/8050	25 _H	VH37	VGMA4+(VGMA3-VGMA4)x	1100/1600
06 _H	VH6	VGMA2+(VGMA1-VGMA2)x	4000/8050	26 _H	VH38	VGMA4+(VGMA3-VGMA4)x	1000/1600
07 _H	VH7	VGMA2+(VGMA1-VGMA2)x	3450/8050	27 _H	VH39	VGMA4+(VGMA3-VGMA4)x	900/1600
08 _H	VH8	VGMA2+(VGMA1-VGMA2)x	2950/8050	28 _H	VH40	VGMA4+(VGMA3-VGMA4)x	800/1600
09 _H	VH9	VGMA2+(VGMA1-VGMA2)x	2450/8050	29 _H	VH41	VGMA4+(VGMA3-VGMA4)x	700/1600
0A _H	VH10	VGMA2+(VGMA1-VGMA2)x	2050/8050	2A _H	VH42	VGMA4+(VGMA3-VGMA4)x	600/1600
0B _H	VH11	VGMA2+(VGMA1-VGMA2)x	1650/8050	2B _H	VH43	VGMA4+(VGMA3-VGMA4)x	500/1600
0C _H	VH12	VGMA2+(VGMA1-VGMA2)x	1300/8050	2C _H	VH44	VGMA4+(VGMA3-VGMA4)x	400/1600
0D _H	VH13	VGMA2+(VGMA1-VGMA2)x	950/8050	2D _H	VH45	VGMA4+(VGMA3-VGMA4)x	300/1600
0E _H	VH14	VGMA2+(VGMA1-VGMA2)x	600/8050	2E _H	VH46	VGMA4+(VGMA3-VGMA4)x	200/1600
0F _H	VH15	VGMA2+(VGMA1-VGMA2)x	300/8050	2F _H	VH47	VGMA4+(VGMA3-VGMA4)x	100/1600
10 _H	VH16	VGMA2		30 _H	VH48	VGMA4	
11 _H	VH17	VGMA3+(VGMA2-VGMA3)x	2450/2750	31 _H	VH49	VGMA5+(VGMA4-VGMA5)x	3350/3450
12 _H	VH18	VGMA3+(VGMA2-VGMA3)x	2200/2750	32 _H	VH50	VGMA5+(VGMA4-VGMA5)x	3250/3450
13 _H	VH19	VGMA3+(VGMA2-VGMA3)x	1950/2750	33 _H	VH51	VGMA5+(VGMA4-VGMA5)x	3150/3450
14 _H	VH20	VGMA3+(VGMA2-VGMA3)x	1700/2750	34 _H	VH52	VGMA5+(VGMA4-VGMA5)x	3050/3450
15 _H	VH21	VGMA3+(VGMA2-VGMA3)x	1500/2750	35 _H	VH53	VGMA5+(VGMA4-VGMA5)x	2950/3450
16 _H	VH22	VGMA3+(VGMA2-VGMA3)x	1300/2750	36 _H	VH54	VGMA5+(VGMA4-VGMA5)x	2800/3450
17 _H	VH23	VGMA3+(VGMA2-VGMA3)x	1100/2750	37 _H	VH55	VGMA5+(VGMA4-VGMA5)x	2650/3450
18 _H	VH24	VGMA3+(VGMA2-VGMA3)x	950/2750	38 _H	VH56	VGMA5+(VGMA4-VGMA5)x	2500/3450
19 _H	VH25	VGMA3+(VGMA2-VGMA3)x	800/2750	39 _H	VH57	VGMA5+(VGMA4-VGMA5)x	2300/3450
1A _H	VH26	VGMA3+(VGMA2-VGMA3)x	650/2750	3A _H	VH58	VGMA5+(VGMA4-VGMA5)x	2100/3450
1B _H	VH27	VGMA3+(VGMA2-VGMA3)x	500/2750	3B _H	VH59	VGMA5+(VGMA4-VGMA5)x	1850/3450
1C _H	VH28	VGMA3+(VGMA2-VGMA3)x	400/2750	3C _H	VH60	VGMA5+(VGMA4-VGMA5)x	1600/3450
1D _H	VH29	VGMA3+(VGMA2-VGMA3)x	300/2750	3D _H	VH61	VGMA5+(VGMA4-VGMA5)x	1300/3450
1E _H	VH30	VGMA3+(VGMA2-VGMA3)x	200/2750	3E _H	VH62	VGMA5+(VGMA4-VGMA5)x	800/3450
1F _H	VH31	VGMA3+(VGMA2-VGMA3)x	100/2750	3F _H	VH63	VGMA5	

FIGURE 12. FPD33584C Upper Gamma Voltages (compatible with NEC μPD17632A)

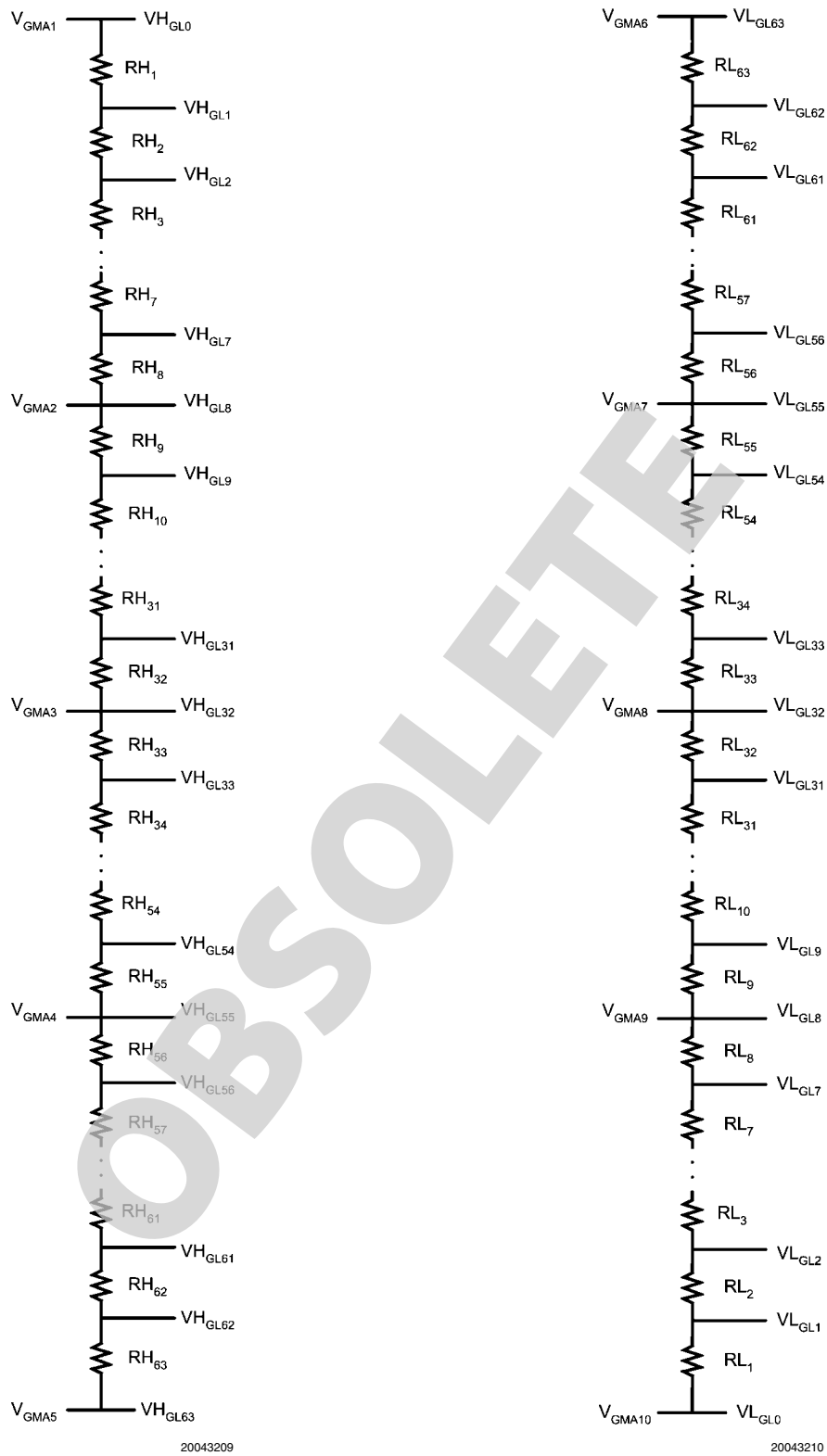

FIGURE 13. FPD33584D R-DAC Configuration (compatible with Hitachi HD66323)

Data	Output Voltage (gamma D)			Data	Output Voltage (gamma D)		
00 _H	VL0	VGMA10		20 _H	VL32	VGMA8	
01 _H	VL1	VGMA9-(VGMA9-VGMA10)x	3690/4613	21 _H	VL33	VGMA7-(VGMA7-VGMA8)x	2783/2902
02 _H	VL2	VGMA9-(VGMA9-VGMA10)x	2917/4613	22 _H	VL34	VGMA7-(VGMA7-VGMA8)x	2664/2902
03 _H	VL3	VGMA9-(VGMA9-VGMA10)x	2307/4613	23 _H	VL35	VGMA7-(VGMA7-VGMA8)x	2545/2902
04 _H	VL4	VGMA9-(VGMA9-VGMA10)x	1696/4613	24 _H	VL36	VGMA7-(VGMA7-VGMA8)x	2426/2902
05 _H	VL5	VGMA9-(VGMA9-VGMA10)x	1235/4613	25 _H	VL37	VGMA7-(VGMA7-VGMA8)x	2321/2902
06 _H	VL6	VGMA9-(VGMA9-VGMA10)x	774/4613	26 _H	VL38	VGMA7-(VGMA7-VGMA8)x	22217/2902
07 _H	VL7	VGMA9-(VGMA9-VGMA10)x	313/4613	27 _H	VL39	VGMA7-(VGMA7-VGMA8)x	2113/2902
08 _H	VL8	VGMA9		28 _H	VL40	VGMA7-(VGMA7-VGMA8)x	2009/2902
09 _H	VL9	VGMA8-(VGMA8-VGMA9)x	3646/3958	29 _H	VL41	VGMA7-(VGMA7-VGMA8)x	1905/2902
0A _H	VL10	VGMA8-(VGMA8-VGMA9)x	3378/3958	2A _H	VL42	VGMA7-(VGMA7-VGMA8)x	1786/2902
0B _H	VL11	VGMA8-(VGMA8-VGMA9)x	3110/3958	2B _H	VL43	VGMA7-(VGMA7-VGMA8)x	1667/2902
0C _H	VL12	VGMA8-(VGMA8-VGMA9)x	2887/3958	2C _H	VL44	VGMA7-(VGMA7-VGMA8)x	1548/2902
0D _H	VL13	VGMA8-(VGMA8-VGMA9)x	2664/3958	2D _H	VL45	VGMA7-(VGMA7-VGMA8)x	1429/2902
0E _H	VL14	VGMA8-(VGMA8-VGMA9)x	2470/3958	2E _H	VL46	VGMA7-(VGMA7-VGMA8)x	1310/2902
0F _H	VL15	VGMA8-(VGMA8-VGMA9)x	2292/3958	2F _H	VL47	VGMA7-(VGMA7-VGMA8)x	1190/2902
10 _H	VL16	VGMA8-(VGMA8-VGMA9)x	2113/3958	30 _H	VL48	VGMA7-(VGMA7-VGMA8)x	1071/2902
11 _H	VL17	VGMA8-(VGMA8-VGMA9)x	1949/3958	31 _H	VL49	VGMA7-(VGMA7-VGMA8)x	952/2902
12 _H	VL18	VGMA8-(VGMA8-VGMA9)x	1801/3958	32 _H	VL50	VGMA7-(VGMA7-VGMA8)x	818/2902
13 _H	VL19	VGMA8-(VGMA8-VGMA9)x	1652/3958	33 _H	VL51	VGMA7-(VGMA7-VGMA8)x	670/2902
14 _H	VL20	VGMA8-(VGMA8-VGMA9)x	1503/3958	34 _H	VL52	VGMA7-(VGMA7-VGMA8)x	521/2902
15 _H	VL21	VGMA8-(VGMA8-VGMA9)x	1369/3958	35 _H	VL53	VGMA7-(VGMA7-VGMA8)x	357/2902
16 _H	VL22	VGMA8-(VGMA8-VGMA9)x	1235/3958	36 _H	VL54	VGMA7-(VGMA7-VGMA8)x	179/2902
17 _H	VL23	VGMA8-(VGMA8-VGMA9)x	1101/3958	37 _H	VL55	VGMA7	
18 _H	VL24	VGMA8-(VGMA8-VGMA9)x	967/3958	38 _H	VL56	VGMA6-(VGMA6-VGMA7)x	3348/3527
19 _H	VL25	VGMA8-(VGMA8-VGMA9)x	833/3958	39 _H	VL57	VGMA6-(VGMA6-VGMA7)x	3125/3527
1A _H	VL26	VGMA8-(VGMA8-VGMA9)x	714/3958	3A _H	VL58	VGMA6-(VGMA6-VGMA7)x	2887/3527
1B _H	VL27	VGMA8-(VGMA8-VGMA9)x	595/3958	3B _H	VL59	VGMA6-(VGMA6-VGMA7)x	2619/3527
1C _H	VL28	VGMA8-(VGMA8-VGMA9)x	476/3958	3C _H	VL60	VGMA6-(VGMA6-VGMA7)x	2307/3527
1D _H	VL29	VGMA8-(VGMA8-VGMA9)x	357/3958	3D _H	VL61	VGMA6-(VGMA6-VGMA7)x	1845/3527
1E _H	VL30	VGMA8-(VGMA8-VGMA9)x	239/3958	3E _H	VL62	VGMA6-(VGMA6-VGMA7)x	1235/3527
1F _H	VL31	VGMA8-(VGMA8-VGMA9)x	119/3958	3F _H	VL63	VGMA6	

FIGURE 14. FPD33584D Lower Gamma Voltages (compatible with Hitach HD66323)

Data	Output Voltage (gamma D)			Data	Output Voltage (gamma D)		
00 _H	VH0	VGMA1		20 _H	VH32	VGMA3	
01 _H	VH1	VGMA2+(VGMA1-VGMA2)×	3690/4613	21 _H	VH33	VGMA4+(VGMA3-VGMA4)×	2783/2902
02 _H	VH2	VGMA2+(VGMA1-VGMA2)×	2917/4613	22 _H	VH34	VGMA4+(VGMA3-VGMA4)×	2664/2902
03 _H	VH3	VGMA2+(VGMA1-VGMA2)×	2307/4613	23 _H	VH35	VGMA4+(VGMA3-VGMA4)×	2545/2902
04 _H	VH4	VGMA2+(VGMA1-VGMA2)×	1696/4613	24 _H	VH36	VGMA4+(VGMA3-VGMA4)×	2426/2902
05 _H	VH5	VGMA2+(VGMA1-VGMA2)×	1235/4613	25 _H	VH37	VGMA4+(VGMA3-VGMA4)×	2321/2902
06 _H	VH6	VGMA2+(VGMA1-VGMA2)×	774/4613	26 _H	VH38	VGMA4+(VGMA3-VGMA4)×	2217/2902
07 _H	VH7	VGMA2+(VGMA1-VGMA2)×	313/4613	27 _H	VH39	VGMA4+(VGMA3-VGMA4)×	2113/2902
08 _H	VH8	VGMA2		28 _H	VH40	VGMA4+(VGMA3-VGMA4)×	2009/2902
09 _H	VH9	VGMA3+(VGMA2-VGMA3)×	3646/3958	29 _H	VH41	VGMA4+(VGMA3-VGMA4)×	1905/2902
0A _H	VH10	VGMA3+(VGMA2-VGMA3)×	3378/3958	2A _H	VH42	VGMA4+(VGMA3-VGMA4)×	1786/2902
0B _H	VH11	VGMA3+(VGMA2-VGMA3)×	3110/3958	2B _H	VH43	VGMA4+(VGMA3-VGMA4)×	1667/2902
0C _H	VH12	VGMA3+(VGMA2-VGMA3)×	2887/3958	2C _H	VH44	VGMA4+(VGMA3-VGMA4)×	1548/2902
0D _H	VH13	VGMA3+(VGMA2-VGMA3)×	2664/3958	2D _H	VH45	VGMA4+(VGMA3-VGMA4)×	1429/2902
0E _H	VH14	VGMA3+(VGMA2-VGMA3)×	2470/3958	2E _H	VH46	VGMA4+(VGMA3-VGMA4)×	1310/2902
0F _H	VH15	VGMA3+(VGMA2-VGMA3)×	2292/3958	2F _H	VH47	VGMA4+(VGMA3-VGMA4)×	1190/2902
10 _H	VH16	VGMA3+(VGMA2-VGMA3)×	2113/3958	30 _H	VH48	VGMA4+(VGMA3-VGMA4)×	1071/2902
11 _H	VH17	VGMA3+(VGMA2-VGMA3)×	1949/3958	31 _H	VH49	VGMA4+(VGMA3-VGMA4)×	952/2902
12 _H	VH18	VGMA3+(VGMA2-VGMA3)×	1801/3958	32 _H	VH50	VGMA4+(VGMA3-VGMA4)×	818/2902
13 _H	VH19	VGMA3+(VGMA2-VGMA3)×	1652/3958	33 _H	VH51	VGMA4+(VGMA3-VGMA4)×	670/2902
14 _H	VH20	VGMA3+(VGMA2-VGMA3)×	1503/3958	34 _H	VH52	VGMA4+(VGMA3-VGMA4)×	521/2902
15 _H	VH21	VGMA3+(VGMA2-VGMA3)×	1369/3958	35 _H	VH53	VGMA4+(VGMA3-VGMA4)×	357/2902
16 _H	VH22	VGMA3+(VGMA2-VGMA3)×	1235/3958	36 _H	VH54	VGMA4+(VGMA3-VGMA4)×	179/2902
17 _H	VH23	VGMA3+(VGMA2-VGMA3)×	1101/3958	37 _H	VH55	VGMA4	
18 _H	VH24	VGMA3+(VGMA2-VGMA3)×	967/3958	38 _H	VH56	VGMA5+(VGMA4-VGMA5)×	3348/3527
19 _H	VH25	VGMA3+(VGMA2-VGMA3)×	833/3958	39 _H	VH57	VGMA5+(VGMA4-VGMA5)×	3125/3527
1A _H	VH26	VGMA3+(VGMA2-VGMA3)×	714/3958	3A _H	VH58	VGMA5+(VGMA4-VGMA5)×	2887/3527
1B _H	VH27	VGMA3+(VGMA2-VGMA3)×	595/3958	3B _H	VH59	VGMA5+(VGMA4-VGMA5)×	2619/3527
1C _H	VH28	VGMA3+(VGMA2-VGMA3)×	476/3958	3C _H	VH60	VGMA5+(VGMA4-VGMA5)×	2307/3527
1D _H	VH29	VGMA3+(VGMA2-VGMA3)×	357/3958	3D _H	VH61	VGMA5+(VGMA4-VGMA5)×	21845/3527
1E _H	VH30	VGMA3+(VGMA2-VGMA3)×	239/3958	3E _H	VH62	VGMA5+(VGMA4-VGMA5)×	1235/3927
1F _H	VH31	VGMA3+(VGMA2-VGMA3)×	119/3958	3F _H	VH63	VGMA5	1235/3527

FIGURE 15. FPD33584D Upper Gamma Voltages (compatible with Hitach HD66323)

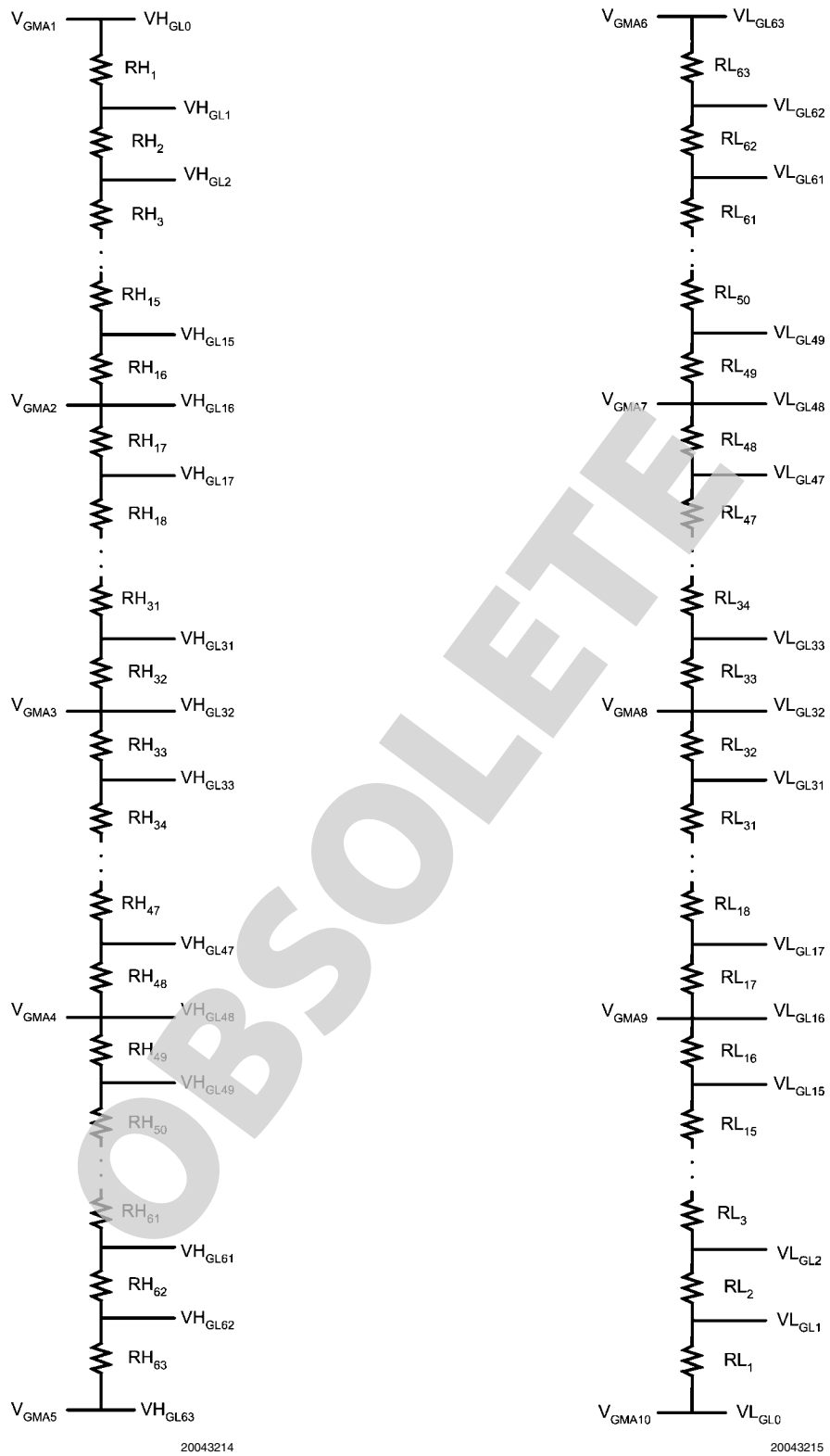

FIGURE 16. FPD33584F R-DAC Configuration

Data	Output Voltage (gamma F)			Data	Output Voltage (gamma F)		
00 _H	VL0	VGMA10		20 _H	VL32	VGMA8	
01 _H	VL1	VGMA9-(VGMA9-VGMA10)x	5536/6459	21 _H	VL33	VGMA7-(VGMA7-VGMA8)x	1710/1829
02 _H	VL2	VGMA9-(VGMA9-VGMA10)x	4762/6459	22 _H	VL34	VGMA7-(VGMA7-VGMA8)x	1591/1829
03 _H	VL3	VGMA9-(VGMA9-VGMA10)x	4152/6459	23 _H	VL35	VGMA7-(VGMA7-VGMA8)x	1472/1829
04 _H	VL4	VGMA9-(VGMA9-VGMA10)x	3542/6459	24 _H	VL36	VGMA7-(VGMA7-VGMA8)x	1353/1829
05 _H	VL5	VGMA9-(VGMA9-VGMA10)x	3081/6459	25 _H	VL37	VGMA7-(VGMA7-VGMA8)x	1249/1829
06 _H	VL6	VGMA9-(VGMA9-VGMA10)x	2620/6459	26 _H	VL38	VGMA7-(VGMA7-VGMA8)x	1145/1829
07 _H	VL7	VGMA9-(VGMA9-VGMA10)x	2159/6459	27 _H	VL39	VGMA7-(VGMA7-VGMA8)x	1041/1829
08 _H	VL8	VGMA9-(VGMA9-VGMA10)x	1846/6459	28 _H	VL40	VGMA7-(VGMA7-VGMA8)x	937/1829
09 _H	VL9	VGMA9-(VGMA9-VGMA10)x	1533/6459	29 _H	VL41	VGMA7-(VGMA7-VGMA8)x	833/1829
0A _H	VL10	VGMA9-(VGMA9-VGMA10)x	1265/6459	2A _H	VL42	VGMA7-(VGMA7-VGMA8)x	714/1829
0B _H	VL11	VGMA9-(VGMA9-VGMA10)x	997/6459	2B _H	VL43	VGMA7-(VGMA7-VGMA8)x	595/1829
0C _H	VL12	VGMA9-(VGMA9-VGMA10)x	774/6459	2C _H	VL44	VGMA7-(VGMA7-VGMA8)x	476/1829
0D _H	VL13	VGMA9-(VGMA9-VGMA10)x	551/6459	2D _H	VL45	VGMA7-(VGMA7-VGMA8)x	357/1829
0E _H	VL14	VGMA9-(VGMA9-VGMA10)x	358/6459	2E _H	VL46	VGMA7-(VGMA7-VGMA8)x	238/1829
0F _H	VL15	VGMA9-(VGMA9-VGMA10)x	179/6459	2F _H	VL47	VGMA7-(VGMA7-VGMA8)x	119/1829
10 _H	VL16	VGMA9		30 _H	VL48	VGMA7	
11 _H	VL17	VGMA8-(VGMA8-VGMA9)x	1950/2114	31 _H	VL49	VGMA6-(VGMA6-VGMA7)x	4481/4600
12 _H	VL18	VGMA8-(VGMA8-VGMA9)x	1801/2114	32 _H	VL50	VGMA6-(VGMA6-VGMA7)x	4347/4600
13 _H	VL19	VGMA8-(VGMA8-VGMA9)x	1652/2114	33 _H	VL51	VGMA6-(VGMA6-VGMA7)x	4198/4600
14 _H	VL20	VGMA8-(VGMA8-VGMA9)x	1503/2114	34 _H	VL52	VGMA6-(VGMA6-VGMA7)x	4049/4600
15 _H	VL21	VGMA8-(VGMA8-VGMA9)x	1369/2114	35 _H	VL53	VGMA6-(VGMA6-VGMA7)x	3885/4600
16 _H	VL22	VGMA8-(VGMA8-VGMA9)x	1235/2114	36 _H	VL54	VGMA6-(VGMA6-VGMA7)x	3706/4600
17 _H	VL23	VGMA8-(VGMA8-VGMA9)x	1101/2114	37 _H	VL55	VGMA6-(VGMA6-VGMA7)x	3527/4600
18 _H	VL24	VGMA8-(VGMA8-VGMA9)x	967/2114	38 _H	VL56	VGMA6-(VGMA6-VGMA7)x	3348/4600
19 _H	VL25	VGMA8-(VGMA8-VGMA9)x	833/2114	39 _H	VL57	VGMA6-(VGMA6-VGMA7)x	3125/4600
1A _H	VL26	VGMA8-(VGMA8-VGMA9)x	714/2114	3A _H	VL58	VGMA6-(VGMA6-VGMA7)x	2887/4600
1B _H	VL27	VGMA8-(VGMA8-VGMA9)x	595/2114	3B _H	VL59	VGMA6-(VGMA6-VGMA7)x	2619/4600
1C _H	VL28	VGMA8-(VGMA8-VGMA9)x	476/2114	3C _H	VL60	VGMA6-(VGMA6-VGMA7)x	2306/4600
1D _H	VL29	VGMA8-(VGMA8-VGMA9)x	357/2114	3D _H	VL61	VGMA6-(VGMA6-VGMA7)x	1845/2600
1E _H	VL30	VGMA8-(VGMA8-VGMA9)x	238/2114	3E _H	VL62	VGMA6-(VGMA6-VGMA7)x	1235/4600
1F _H	VL31	VGMA8-(VGMA8-VGMA9)x	119/2114	3F _H	VL63	VGMA6	

FIGURE 17. FPD33584F Lower Gamma Voltages

Data	Output Voltage (gamma F)			Data	Output Voltage (gamma F)		
00 _H	VH0	VGMA1		20 _H	VH32	VGMA3	
01 _H	VH1	VGMA2+(VGMA1-VGMA2)x	5536/6459	21 _H	VH33	VGMA4+(VGMA3-VGMA4)x	1710/1829
02 _H	VH2	VGMA2+(VGMA1-VGMA2)x	4762/6459	22 _H	VH34	VGMA4+(VGMA3-VGMA4)x	1591/1829
03 _H	VH3	VGMA2+(VGMA1-VGMA2)x	4152/6459	23 _H	VH35	VGMA4+(VGMA3-VGMA4)x	1472/1829
04 _H	VH4	VGMA2+(VGMA1-VGMA2)x	3542/6459	24 _H	VH36	VGMA4+(VGMA3-VGMA4)x	1353/1829
05 _H	VH5	VGMA2+(VGMA1-VGMA2)x	3081/6459	25 _H	VH37	VGMA4+(VGMA3-VGMA4)x	1249/1829
06 _H	VH6	VGMA2+(VGMA1-VGMA2)x	2620/6459	26 _H	VH38	VGMA4+(VGMA3-VGMA4)x	1145/1829
07 _H	VH7	VGMA2+(VGMA1-VGMA2)x	2159/6459	27 _H	VH39	VGMA4+(VGMA3-VGMA4)x	1041/1829
08 _H	VH8	VGMA2+(VGMA1-VGMA2)x	1846/6459	28 _H	VH40	VGMA4+(VGMA3-VGMA4)x	937/1829
09 _H	VH9	VGMA2+(VGMA1-VGMA2)x	1533/6459	29 _H	VH41	VGMA4+(VGMA3-VGMA4)x	833/1829
0A _H	VH10	VGMA2+(VGMA1-VGMA2)x	1265/6459	2A _H	VH42	VGMA4+(VGMA3-VGMA4)x	714/1829
0B _H	VH11	VGMA2+(VGMA1-VGMA2)x	997/6459	2B _H	VH43	VGMA4+(VGMA3-VGMA4)x	595/1829
0C _H	VH12	VGMA2+(VGMA1-VGMA2)x	774/6459	2C _H	VH44	VGMA4+(VGMA3-VGMA4)x	476/1829
0D _H	VH13	VGMA2+(VGMA1-VGMA2)x	551/6459	2D _H	VH45	VGMA4+(VGMA3-VGMA4)x	357/1829
0E _H	VH14	VGMA2+(VGMA1-VGMA2)x	358/6459	2E _H	VH46	VGMA4+(VGMA3-VGMA4)x	238/1829
0F _H	VH15	VGMA2+(VGMA1-VGMA2)x	179/6459	2F _H	VH47	VGMA4+(VGMA3-VGMA4)x	119/1829
10 _H	VH16	VGMA2		30 _H	VH48	VGMA4	
11 _H	VH17	VGMA3+(VGMA2-VGMA3)x	1950/2114	31 _H	VH49	VGMA5+(VGMA4-VGMA5)x	4481/4600
12 _H	VH18	VGMA3+(VGMA2-VGMA3)x	1801/2114	32 _H	VH50	VGMA5+(VGMA4-VGMA5)x	4347/4600
13 _H	VH19	VGMA3+(VGMA2-VGMA3)x	1652/2114	33 _H	VH51	VGMA5+(VGMA4-VGMA5)x	4198/4600
14 _H	VH20	VGMA3+(VGMA2-VGMA3)x	1503/2114	34 _H	VH52	VGMA5+(VGMA4-VGMA5)x	4049/4600
15 _H	VH21	VGMA3+(VGMA2-VGMA3)x	1369/2114	35 _H	VH53	VGMA5+(VGMA4-VGMA5)x	3885/4600
16 _H	VH22	VGMA3+(VGMA2-VGMA3)x	1235/2114	36 _H	VH54	VGMA5+(VGMA4-VGMA5)x	3706/4600
17 _H	VH23	VGMA3+(VGMA2-VGMA3)x	1101/2114	37 _H	VH55	VGMA5+(VGMA4-VGMA5)x	3527/4600
18 _H	VH24	VGMA3+(VGMA2-VGMA3)x	967/2114	38 _H	VH56	VGMA5+(VGMA4-VGMA5)x	3348/4600
19 _H	VH25	VGMA3+(VGMA2-VGMA3)x	833/2114	39 _H	VH57	VGMA5+(VGMA4-VGMA5)x	3125/4600
1A _H	VH26	VGMA3+(VGMA2-VGMA3)x	714/2114	3A _H	VH58	VGMA5+(VGMA4-VGMA5)x	2887/4600
1B _H	VH27	VGMA3+(VGMA2-VGMA3)x	595/2114	3B _H	VH59	VGMA5+(VGMA4-VGMA5)x	2619/4600
1C _H	VH28	VGMA3+(VGMA2-VGMA3)x	476/2114	3C _H	VH60	VGMA5+(VGMA4-VGMA5)x	2306/4600
1D _H	VH29	VGMA3+(VGMA2-VGMA3)x	357/2114	3D _H	VH61	VGMA5+(VGMA4-VGMA5)x	1845/4600
1E _H	VH30	VGMA3+(VGMA2-VGMA3)x	238/2114	3E _H	VH62	VGMA5+(VGMA4-VGMA5)x	1235/4600
1F _H	VH31	VGMA3+(VGMA2-VGMA3)x	119/2114	3F _H	VH63	VGMA5	

FIGURE 18. FPD33584F Upper Gamma Voltages

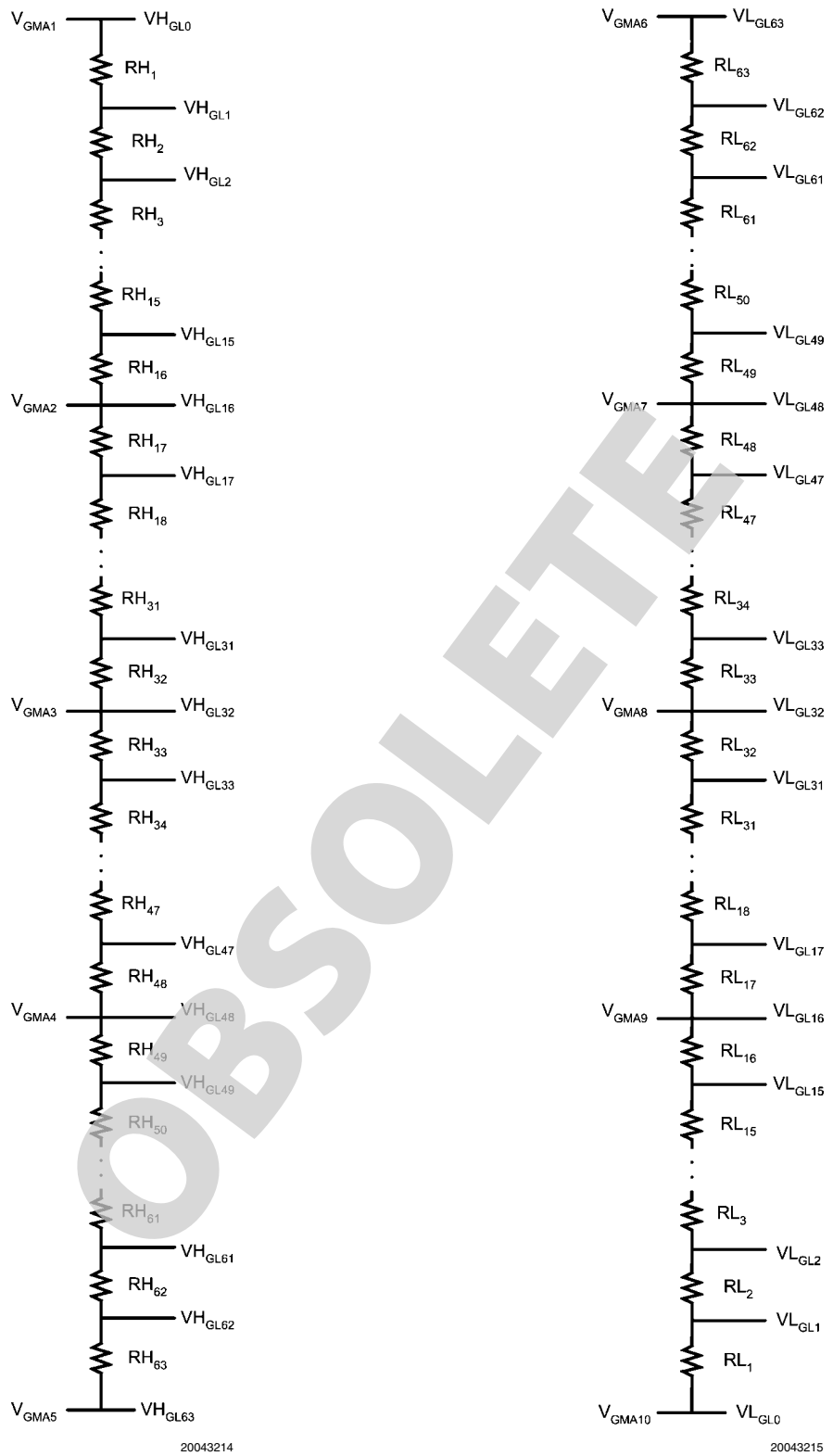

FIGURE 19. FPD33584G R-DAC Configuration

Data	Output Voltage (gamma G)			Data	Output Voltage (gamma G)		
00 _H	VL0	VGMA10		20 _H	VL32	VGMA8	
01 _H	VL1	VGMA9-(VGMA9-VGMA10)×	6027/6667	21 _H	VL33	VGMA7-(VGMA7-VGMA8)×	1500/1604
02 _H	VL2	VGMA9-(VGMA9-VGMA10)×	5432/6667	22 _H	VL34	VGMA7-(VGMA7-VGMA8)×	1396/1604
03 _H	VL3	VGMA9-(VGMA9-VGMA10)×	4837/6667	23 _H	VL35	VGMA7-(VGMA7-VGMA8)×	1307/1604
04 _H	VL4	VGMA9-(VGMA9-VGMA10)×	4257/6667	24 _H	VL36	VGMA7-(VGMA7-VGMA8)×	1218/1604
05 _H	VL5	VGMA9-(VGMA9-VGMA10)×	3692/6667	25 _H	VL37	VGMA7-(VGMA7-VGMA8)×	1114/1604
06 _H	VL6	VGMA9-(VGMA9-VGMA10)×	3186/6667	26 _H	VL38	VGMA7-(VGMA7-VGMA8)×	1010/1604
07 _H	VL7	VGMA9-(VGMA9-VGMA10)×	2769/6667	27 _H	VL39	VGMA7-(VGMA7-VGMA8)×	906/1604
08 _H	VL8	VGMA9-(VGMA9-VGMA10)×	2352/6667	28 _H	VL40	VGMA7-(VGMA7-VGMA8)×	817/1604
09 _H	VL9	VGMA9-(VGMA9-VGMA10)×	1920/6667	29 _H	VL41	VGMA7-(VGMA7-VGMA8)×	713/1604
0A _H	VL10	VGMA9-(VGMA9-VGMA10)×	1533/6667	2A _H	VL42	VGMA7-(VGMA7-VGMA8)×	624/1604
0B _H	VL11	VGMA9-(VGMA9-VGMA10)×	1220/6667	2B _H	VL43	VGMA7-(VGMA7-VGMA8)×	520/1604
0C _H	VL12	VGMA9-(VGMA9-VGMA10)×	937/6667	2C _H	VL44	VGMA7-(VGMA7-VGMA8)×	431/1604
0D _H	VL13	VGMA9-(VGMA9-VGMA10)×	684/6667	2D _H	VL45	VGMA7-(VGMA7-VGMA8)×	327/1604
0E _H	VL14	VGMA9-(VGMA9-VGMA10)×	431/6667	2E _H	VL46	VGMA7-(VGMA7-VGMA8)×	208/1604
0F _H	VL15	VGMA9-(VGMA9-VGMA10)×	208/6667	2F _H	VL47	VGMA7-(VGMA7-VGMA8)×	104/1604
10 _H	VL16	VGMA9		30 _H	VL48	VGMA7	
11 _H	VL17	VGMA8-(VGMA8-VGMA9)×	1949/2142	31 _H	VL49	VGMA6-(VGMA6-VGMA7)×	4479/4583
12 _H	VL18	VGMA8-(VGMA8-VGMA9)×	1756/2142	32 _H	VL50	VGMA6-(VGMA6-VGMA7)×	4360/4583
13 _H	VL19	VGMA8-(VGMA8-VGMA9)×	1592/2142	33 _H	VL51	VGMA6-(VGMA6-VGMA7)×	4241/4583
14 _H	VL20	VGMA8-(VGMA8-VGMA9)×	1443/2142	34 _H	VL52	VGMA6-(VGMA6-VGMA7)×	4122/4583
15 _H	VL21	VGMA8-(VGMA8-VGMA9)×	1294/2142	35 _H	VL53	VGMA6-(VGMA6-VGMA7)×	4003/4583
16 _H	VL22	VGMA8-(VGMA8-VGMA9)×	1160/2142	36 _H	VL54	VGMA6-(VGMA6-VGMA7)×	3869/4583
17 _H	VL23	VGMA8-(VGMA8-VGMA9)×	1026/2142	37 _H	VL55	VGMA6-(VGMA6-VGMA7)×	3735/4583
18 _H	VL24	VGMA8-(VGMA8-VGMA9)×	892/2142	38 _H	VL56	VGMA6-(VGMA6-VGMA7)×	3571/4583
19 _H	VL25	VGMA8-(VGMA8-VGMA9)×	758/2142	39 _H	VL57	VGMA6-(VGMA6-VGMA7)×	3392/4583
1A _H	VL26	VGMA8-(VGMA8-VGMA9)×	639/2142	3A _H	VL58	VGMA6-(VGMA6-VGMA7)×	3184/4583
1B _H	VL27	VGMA8-(VGMA8-VGMA9)×	520/2142	3B _H	VL59	VGMA6-(VGMA6-VGMA7)×	2991/4583
1C _H	VL28	VGMA8-(VGMA8-VGMA9)×	416/2142	3C _H	VL60	VGMA6-(VGMA6-VGMA7)×	2753/4583
1D _H	VL29	VGMA8-(VGMA8-VGMA9)×	312/2142	3D _H	VL61	VGMA6-(VGMA6-VGMA7)×	2426/4583
1E _H	VL30	VGMA8-(VGMA8-VGMA9)×	208/2142	3E _H	VL62	VGMA6-(VGMA6-VGMA7)×	1875/4583
1F _H	VL31	VGMA8-(VGMA8-VGMA9)×	104/2142	3F _H	VL63	VGMA6	

FIGURE 20. FPD33584G Lower Gamma Voltages

Data	Output Voltage (gamma G)			Data	Output Voltage (gamma G)		
00 _H	VH0	VGMA1		20 _H	VH32	VGMA3	
01 _H	VH1	VGMA2+(VGMA1-VGMA2)×	6027/6667	21 _H	VH33	VGMA4+(VGMA3-VGMA4)×	1500/1604
02 _H	VH2	VGMA2+(VGMA1-VGMA2)×	5432/6667	22 _H	VH34	VGMA4+(VGMA3-VGMA4)×	1396/1604
03 _H	VH3	VGMA2+(VGMA1-VGMA2)×	4837/6667	23 _H	VH35	VGMA4+(VGMA3-VGMA4)×	1307/1604
04 _H	VH4	VGMA2+(VGMA1-VGMA2)×	4257/6667	24 _H	VH36	VGMA4+(VGMA3-VGMA4)×	1218/1604
05 _H	VH5	VGMA2+(VGMA1-VGMA2)×	3692/6667	25 _H	VH37	VGMA4+(VGMA3-VGMA4)×	1114/1604
06 _H	VH6	VGMA2+(VGMA1-VGMA2)×	3186/6667	26 _H	VH38	VGMA4+(VGMA3-VGMA4)×	1010/1604
07 _H	VH7	VGMA2+(VGMA1-VGMA2)×	2769/6667	27 _H	VH39	VGMA4+(VGMA3-VGMA4)×	906/1604
08 _H	VH8	VGMA2+(VGMA1-VGMA2)×	2352/6667	28 _H	VH40	VGMA4+(VGMA3-VGMA4)×	817/1604
09 _H	VH9	VGMA2+(VGMA1-VGMA2)×	1920/6667	29 _H	VH41	VGMA4+(VGMA3-VGMA4)×	713/1604
0A _H	VH10	VGMA2+(VGMA1-VGMA2)×	1533/6667	2A _H	VH42	VGMA4+(VGMA3-VGMA4)×	624/1604
0B _H	VH11	VGMA2+(VGMA1-VGMA2)×	1220/6667	2B _H	VH43	VGMA4+(VGMA3-VGMA4)×	520/1604
0C _H	VH12	VGMA2+(VGMA1-VGMA2)×	937/6667	2C _H	VH44	VGMA4+(VGMA3-VGMA4)×	431/1604
0D _H	VH13	VGMA2+(VGMA1-VGMA2)×	684/6667	2D _H	VH45	VGMA4+(VGMA3-VGMA4)×	327/1604
0E _H	VH14	VGMA2+(VGMA1-VGMA2)×	431/6667	2E _H	VH46	VGMA4+(VGMA3-VGMA4)×	208/1604
0F _H	VH15	VGMA2+(VGMA1-VGMA2)×	208/6667	2F _H	VH47	VGMA4+(VGMA3-VGMA4)×	104/1604
10 _H	VH16	VGMA2		30 _H	VH48	VGMA4	
11 _H	VH17	VGMA3+(VGMA2-VGMA3)×	1949/2142	31 _H	VH49	VGMA5+(VGMA4-VGMA5)×	4479/4583
12 _H	VH18	VGMA3+(VGMA2-VGMA3)×	1756/2142	32 _H	VH50	VGMA5+(VGMA4-VGMA5)×	4360/4583
13 _H	VH19	VGMA3+(VGMA2-VGMA3)×	1592/2142	33 _H	VH51	VGMA5+(VGMA4-VGMA5)×	4241/4583
14 _H	VH20	VGMA3+(VGMA2-VGMA3)×	1443/2142	34 _H	VH52	VGMA5+(VGMA4-VGMA5)×	4122/4583
15 _H	VH21	VGMA3+(VGMA2-VGMA3)×	1294/2142	35 _H	VH53	VGMA5+(VGMA4-VGMA5)×	4003/4583
16 _H	VH22	VGMA3+(VGMA2-VGMA3)×	1160/2142	36 _H	VH54	VGMA5+(VGMA4-VGMA5)×	3869/4583
17 _H	VH23	VGMA3+(VGMA2-VGMA3)×	1026/2142	37 _H	VH55	VGMA5+(VGMA4-VGMA5)×	3735/4583
18 _H	VH24	VGMA3+(VGMA2-VGMA3)×	892/2142	38 _H	VH56	VGMA5+(VGMA4-VGMA5)×	3571/4583
19 _H	VH25	VGMA3+(VGMA2-VGMA3)×	758/2142	39 _H	VH57	VGMA5+(VGMA4-VGMA5)×	3392/4583
1A _H	VH26	VGMA3+(VGMA2-VGMA3)×	639/2142	3A _H	VH58	VGMA5+(VGMA4-VGMA5)×	3184/4583
1B _H	VH27	VGMA3+(VGMA2-VGMA3)×	520/2142	3B _H	VH59	VGMA5+(VGMA4-VGMA5)×	2991/4583
1C _H	VH28	VGMA3+(VGMA2-VGMA3)×	416/2142	3C _H	VH60	VGMA5+(VGMA4-VGMA5)×	2753/4583
1D _H	VH29	VGMA3+(VGMA2-VGMA3)×	312/2142	3D _H	VH61	VGMA5+(VGMA4-VGMA5)×	2426/4583
1E _H	VH30	VGMA3+(VGMA2-VGMA3)×	208/2142	3E _H	VH62	VGMA5+(VGMA4-VGMA5)×	1875/4583
1F _H	VH31	VGMA3+(VGMA2-VGMA3)×	104/2142	3F _H	VH63	VGMA5	

FIGURE 21. FPD33584G Upper Gamma Voltages

R	A (Ω)	B (Ω)	C (Ω)	D (Ω)	F (Ω)	G (Ω)	R	A (Ω)	B (Ω)	C (Ω)	D (Ω)	F (Ω)	G (Ω)
Rx1	1830	402	800	923	923	640	Rx33	104	134	100	119	119	104
Rx2	1027	402	750	774	774	595	Rx34	104	134	100	119	119	104
Rx3	739	402	700	610	610	595	Rx35	104	134	100	119	119	89
Rx4	625	402	650	610	610	580	Rx36	104	134	100	119	119	89
Rx5	521	402	600	461	461	565	Rx37	104	134	100	104	104	104
Rx6	417	402	550	461	461	506	Rx38	104	134	100	104	104	104
Rx7	417	402	550	461	461	417	Rx39	104	134	100	104	104	104
Rx8	313	402	500	313	313	417	Rx40	104	134	100	104	104	89
Rx9	313	402	500	313	313	432	Rx41	104	134	100	104	104	104
Rx10	208	402	400	268	268	387	Rx42	104	134	100	119	119	89
Rx11	208	402	400	268	268	313	Rx43	104	134	100	119	119	104
Rx12	149	402	350	223	223	283	Rx44	119	134	100	119	119	89
Rx13	149	357	350	223	223	253	Rx45	119	134	100	119	119	104
Rx14	134	357	350	193	193	253	Rx46	119	134	100	119	119	119
Rx15	134	313	300	179	179	223	Rx47	119	149	100	119	119	104
Rx16	119	298	300	179	179	208	Rx48	119	149	100	119	119	104
Rx17	119	268	300	164	164	193	Rx49	119	164	100	119	119	104
Rx18	119	268	250	149	149	193	Rx50	119	179	100	134	134	119
Rx19	119	268	250	149	149	164	Rx51	134	179	100	149	149	119
Rx20	119	253	250	149	149	149	Rx52	134	193	100	149	149	119
Rx21	104	238	200	134	134	149	Rx53	149	193	100	164	164	119
Rx22	104	223	200	134	134	134	Rx54	149	208	150	179	179	134
Rx23	104	208	200	134	134	134	Rx55	149	208	150	179	179	134
Rx24	104	208	150	134	134	134	Rx56	149	238	150	179	179	164
Rx25	104	193	150	134	134	134	Rx57	193	238	200	223	223	179
Rx26	104	193	150	119	119	119	Rx58	223	253	200	238	238	208
Rx27	104	179	150	119	119	119	Rx59	253	253	250	268	268	193
Rx28	104	179	100	119	119	104	Rx60	313	268	250	313	313	238
Rx29	104	164	100	119	119	104	Rx61	521	268	300	461	461	327
Rx30	104	164	100	119	119	104	Rx62	714	268	500	610	610	551
Rx31	104	149	100	119	119	104	Rx63	923	268	800	1235	1235	1875
Rx32	104	149	100	119	119	104	Rtotal	14998	15005	15850	15000	15000	15002

FIGURE 22. FPD33584 R-DAC Resistance Values

INPUTS		OUTPUTS	
optional	RPI2		Y384
optional	RPIO2		Y383
	DIO2		Y382
	D22P		.
	D22N		.
	D21P		.
	D21N		.
	D20P		.
	D20N		.
	D12P		.
	D12N		.
	D11P		.
	D11N		.
	D10P		.
	D10N		.
	VDD1		.
	SHL		.
	VGMA10		.
optional	VGMA9		.
optional	VGMA8		.
optional	VGMA7		.
	VGMA6		.
	VDD2		.
	VSS2		.
	VGMA5		.
optional	VGMA4		.
optional	VGMA3		.
optional	VGMA2		.
	VGMA1		.
	VSS1		.
	CLKP		.
	CLKN		.
	CLK1		.
	POL		.
optional	DATPOL		.
	D02P		.
	D02N		.
	D01P		.
	D01N		.
	D00P		.
	D00N		.
	DIO1		Y3
optional	RPO1		Y2
optional	RPI1		Y1

FPD33584

Note: This figure represents a FPD33584 die oriented pad side up.

FIGURE 23. FPD33584 I/O Configuration

Ordering Information

Part Number	Gamma Curve	Custom Package #	Package Suffix	Package Type
FPD33584	A, B, C, D, F, G	XX	CT	TCP
FPD33584	A, B, C, D, F, G	XX	CF	COF

Note 12: Custom Package # is assigned by National Semiconductor for each custom TCP or COF design

OBSOLETE

OBSOLETE

Notes

For more National Semiconductor product information and proven design tools, visit the following Web sites at:
www.national.com

Products		Design Support	
Amplifiers	www.national.com/amplifiers	WEBENCH® Tools	www.national.com/webench
Audio	www.national.com/audio	App Notes	www.national.com/appnotes
Clock and Timing	www.national.com/timing	Reference Designs	www.national.com/refdesigns
Data Converters	www.national.com/adc	Samples	www.national.com/samples
Interface	www.national.com/interface	Eval Boards	www.national.com/evalboards
LVDS	www.national.com/lvds	Packaging	www.national.com/packaging
Power Management	www.national.com/power	Green Compliance	www.national.com/quality/green
Switching Regulators	www.national.com/switchers	Distributors	www.national.com/contacts
LDOs	www.national.com/ldo	Quality and Reliability	www.national.com/quality
LED Lighting	www.national.com/led	Feedback/Support	www.national.com/feedback
Voltage References	www.national.com/vref	Design Made Easy	www.national.com/easy
PowerWise® Solutions	www.national.com/powerwise	Applications & Markets	www.national.com/solutions
Serial Digital Interface (SDI)	www.national.com/sdi	Mil/Aero	www.national.com/milaero
Temperature Sensors	www.national.com/tempensors	SolarMagic™	www.national.com/solarmagic
PLL/VCO	www.national.com/wireless	PowerWise® Design University	www.national.com/training

THE CONTENTS OF THIS DOCUMENT ARE PROVIDED IN CONNECTION WITH NATIONAL SEMICONDUCTOR CORPORATION ("NATIONAL") PRODUCTS. NATIONAL MAKES NO REPRESENTATIONS OR WARRANTIES WITH RESPECT TO THE ACCURACY OR COMPLETENESS OF THE CONTENTS OF THIS PUBLICATION AND RESERVES THE RIGHT TO MAKE CHANGES TO SPECIFICATIONS AND PRODUCT DESCRIPTIONS AT ANY TIME WITHOUT NOTICE. NO LICENSE, WHETHER EXPRESS, IMPLIED, ARISING BY ESTOPPEL OR OTHERWISE, TO ANY INTELLECTUAL PROPERTY RIGHTS IS GRANTED BY THIS DOCUMENT.

TESTING AND OTHER QUALITY CONTROLS ARE USED TO THE EXTENT NATIONAL DEEMS NECESSARY TO SUPPORT NATIONAL'S PRODUCT WARRANTY. EXCEPT WHERE MANDATED BY GOVERNMENT REQUIREMENTS, TESTING OF ALL PARAMETERS OF EACH PRODUCT IS NOT NECESSARILY PERFORMED. NATIONAL ASSUMES NO LIABILITY FOR APPLICATIONS ASSISTANCE OR BUYER PRODUCT DESIGN. BUYERS ARE RESPONSIBLE FOR THEIR PRODUCTS AND APPLICATIONS USING NATIONAL COMPONENTS. PRIOR TO USING OR DISTRIBUTING ANY PRODUCTS THAT INCLUDE NATIONAL COMPONENTS, BUYERS SHOULD PROVIDE ADEQUATE DESIGN, TESTING AND OPERATING SAFEGUARDS.

EXCEPT AS PROVIDED IN NATIONAL'S TERMS AND CONDITIONS OF SALE FOR SUCH PRODUCTS, NATIONAL ASSUMES NO LIABILITY WHATSOEVER, AND NATIONAL DISCLAIMS ANY EXPRESS OR IMPLIED WARRANTY RELATING TO THE SALE AND/OR USE OF NATIONAL PRODUCTS INCLUDING LIABILITY OR WARRANTIES RELATING TO FITNESS FOR A PARTICULAR PURPOSE, MERCHANTABILITY, OR INFRINGEMENT OF ANY PATENT, COPYRIGHT OR OTHER INTELLECTUAL PROPERTY RIGHT.

LIFE SUPPORT POLICY

NATIONAL'S PRODUCTS ARE NOT AUTHORIZED FOR USE AS CRITICAL COMPONENTS IN LIFE SUPPORT DEVICES OR SYSTEMS WITHOUT THE EXPRESS PRIOR WRITTEN APPROVAL OF THE CHIEF EXECUTIVE OFFICER AND GENERAL COUNSEL OF NATIONAL SEMICONDUCTOR CORPORATION. As used herein:

Life support devices or systems are devices which (a) are intended for surgical implant into the body, or (b) support or sustain life and whose failure to perform when properly used in accordance with instructions for use provided in the labeling can be reasonably expected to result in a significant injury to the user. A critical component is any component in a life support device or system whose failure to perform can be reasonably expected to cause the failure of the life support device or system or to affect its safety or effectiveness.

National Semiconductor and the National Semiconductor logo are registered trademarks of National Semiconductor Corporation. All other brand or product names may be trademarks or registered trademarks of their respective holders.

Copyright© 2011 National Semiconductor Corporation

For the most current product information visit us at www.national.com

National Semiconductor
Americas Technical
Support Center
 Email: support@nsc.com
 Tel: 1-800-272-9959

National Semiconductor Europe
Technical Support Center
 Email: europe.support@nsc.com

National Semiconductor Asia
Pacific Technical Support Center
 Email: ap.support@nsc.com

National Semiconductor Japan
Technical Support Center
 Email: jpn.feedback@nsc.com