

**MOS POWER 4**  
**IGBT** T-39-31

**SML25G100AN 1000V 25A**

## N - CHANNEL ENHANCEMENT MODE HIGH VOLTAGE POWER INSULATED GATE BIPOLAR TRANSISTOR

### MAXIMUM RATINGS

All Ratings:  $T_C = 25^\circ\text{C}$  unless otherwise specified.

Symbol	Parameter	SML25G100AN	UNIT
$V_{CES}$	Collector-Emitter Voltage	1000	Volts
$V_{GE}$	Gate-Emitter Voltage	$\pm 20$	
$I_{C1}$	Continuous Collector Current	25	Amps
$I_{C2}$	Continuous Collector Current @ $T_C = 100^\circ\text{C}$	15	
$I_{CM}$	Pulsed Collector Current <sup>①</sup>	50	
$I_{LM}$	Clamped Inductive Load Current @ $T_J = +125^\circ\text{C}$ <sup>②</sup>	30	
$P_D$	Total Power Dissipation	115	Watts
$T_J, T_{STG}$	Operating and Storage Junction Temperature Range	-55 to 150	$^\circ\text{C}$
$T_L$	Max. Lead Temp. for Soldering Conditions: 0.063" from Case for 10 Sec.	300	

### STATIC ELECTRICAL CHARACTERISTICS

Symbol	Characteristic / Test Conditions	MIN	TYP	MAX	UNIT
$BV_{CES}$	Collector-Emitter Breakdown Voltage ( $V_{GE} = 0V, I_C = 250\mu\text{A}$ )	1000			Volts
$RBV_{CES}$	Reverse Collector-Emitter Breakdown Voltage ( $V_{GE} = 0V, I_C = -1.0A$ )	-15	-25		
$V_{GE(TH)}$	Gate Threshold Voltage ( $V_{CE} = V_{GE}, I_C = 1.0mA$ )	2.5		5	
$V_{CE(ON)}$	Collector-Emitter On Voltage ( $V_{GE} = 15V, I_C = I_{C2}$ )			3.6	
$I_{CES}$	Collector Cut-off Current ( $V_{CE} = V_{CES}, V_{GE} = 0V$ )			250	$\mu\text{A}$
	Collector Cut-off Current ( $V_{CE} = 0.8 V_{CES}, V_{GE} = 0V, T_C = 125^\circ\text{C}$ )			1.0	mA
$I_{GES}$	Gate-Emitter Leakage Current ( $V_{GE} = \pm 20V, V_{CE} = 0V$ )			$\pm 100$	nA

### THERMAL CHARACTERISTICS

Symbol	Characteristic	MIN	TYP	MAX	UNIT
$R_{\theta JC}$	Junction to Case			1.08	$^\circ\text{C/W}$
$R_{\theta JA}$	Junction to Ambient			30	

**SEMELAB PLC**  
**Coventry Road,**  
**Lutterworth,**  
**Leicestershire,**  
**LE17 4JB.**

**Telephone: (0455) 556565**  
**Telex: 341927**  
**Facsimile: (0455) 552612**

**DYNAMIC CHARACTERISTICS**

**SML25G100AN**

Symbol	Characteristic	Test Conditions	MIN	TYP	MAX	UNIT
$C_{ies}$	Input Capacitance	$V_{GE} = 0V$ $V_{CE} = 25V$ $f = 1\text{ MHz}$			1235	pF
$C_{oes}$	Output Capacitance				155	
$C_{res}$	Reverse Transfer Capacitance				55	
$Q_g$	Total Gate Charge <sup>③</sup>	$V_{GE} = 10V$ $V_{CC} = 0.5 V_{CES}$ $I_C = I_{C1}$		38	57	nC
$Q_{ge}$	Gate-Emitter Charge			5	7	
$Q_{gc}$	Gate-Collector ("Miller") Charge			22	34	
$t_{d(on)}$	Turn-on Delay Time (Resistive Switching)	$V_{GE} = 15V$ $V_{CC} = 0.5 V_{CES}$ $I_C = I_{C2}$ $R_G = 50\Omega$		75		ns
$t_r$	Rise Time (Resistive Switching)			200		
$t_{d(off)}$	Turn-off Delay Time (Resistive Switching)			600		
$t_f$	Fall Time (Resistive Switching)			600		
$t_{d(off)}$	Turn-off Delay Time (Inductive Switching)	$V_{CLAMP(Peak)} = 0.8V_{CES}$ $V_{GE} = 15V, I_C = I_{C2}$ $R_G = 50\Omega, T_J = 125^\circ C$		750		ns
$t_f$	Fall Time (Inductive Switching)			600		

① Repetitive Rating: Pulse width limited by maximum junction temperature.

②  $V_{CLAMP} = 0.8V_{CES}$  Volts,  $R_G = 50\Omega$ .

③ See MIL-STD-750 Method 3471

**TO-3 Package Outline (TO-204AA)**

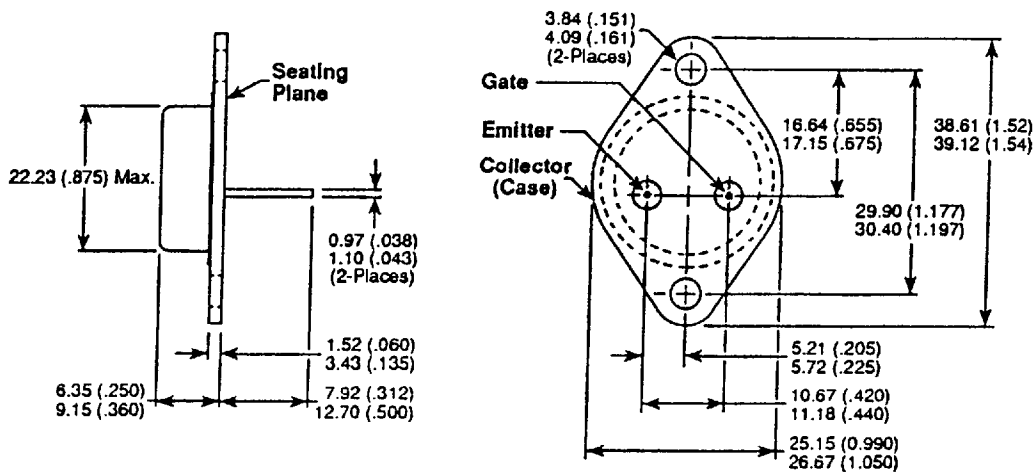

Dimensions in Millimeters and (Inches)

### TYPICAL SOURCE-DRAIN DIODE FORWARD VOLTAGE

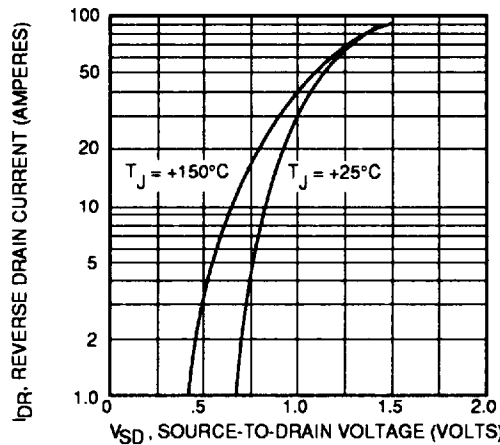
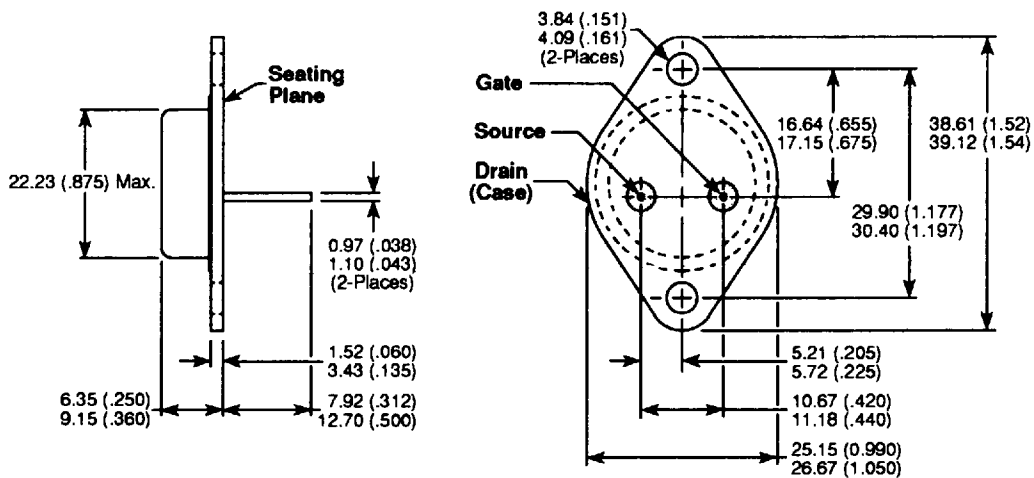

FIGURE 13, TYPICAL SOURCE-DRAIN DIODE FORWARD VOLTAGE

This curve shows the reverse drain current and source-drain forward voltage characteristics of the parasitic diode. The temperature coefficient (TC) of the diode can be derived by utilizing the following formula:

$$TC = \frac{V_{SD}(150^{\circ}C) - V_{SD}(25^{\circ}C)}{125^{\circ}C}$$

### PACKAGE OUTLINE



Dimensions in Millimeters and (Inches)

This drawing gives all the mechanical drawings and dimensions for the package. This is a standard package and conforms to the present industry standards. For further information, contact the factory.