

To all our customers

Regarding the change of names mentioned in the document, such as Mitsubishi Electric and Mitsubishi XX, to Renesas Technology Corp.

The semiconductor operations of Hitachi and Mitsubishi Electric were transferred to Renesas Technology Corporation on April 1st 2003. These operations include microcomputer, logic, analog and discrete devices, and memory chips other than DRAMs (flash memory, SRAMs etc.) Accordingly, although Mitsubishi Electric, Mitsubishi Electric Corporation, Mitsubishi Semiconductors, and other Mitsubishi brand names are mentioned in the document, these names have in fact all been changed to Renesas Technology Corp. Thank you for your understanding. Except for our corporate trademark, logo and corporate statement, no changes whatsoever have been made to the contents of the document, and these changes do not constitute any alteration to the contents of the document itself.

Note : Mitsubishi Electric will continue the business operations of high frequency & optical devices and power devices.

Renesas Technology Corp.
Customer Support Dept.
April 1, 2003

PRELIMINARY
 Notice ; This is not a final specification.
 some parametric limits are subject to change.

M65831AP/FP

DIGITAL ECHO (DIGITAL DELAY)

DESCRIPTION

The M65831A is an IC developed for producing echo effects added to voice signals picked up by microphone for karaoke applications.

The IC has the largest memory among the digital delay series. As its design is aimed at high performance, it is best suited to provide radio cassette tape recorders and miniature unit audio system with quality echo function.

Being pin compatible with the M65830CP / FP and M65843AP / FP, the M65831AP / FP is suitable for upgrading the series.

FEATURES

- Built-in input / output filters, A-D and D-A converters, and memory realize a delay system with only a single chip
- Capable of composing low-noise and low-distortion delay system at low cost by ADM system
 (No=-92dB typ, THD=0.5% typ)
- Control mode selections available from 2 kinds : easy mode using parallel data and microcomputer mode using serial data
- Sleep mode can be selected to stop IC functions
- Built-in automatic reset circuit

RECOMMENDED OPERATING CONDITIONS

Supply voltage range ----- VCC,VDD=4.5 to 5.5V

Rated supply voltage ----- VCC,VDD=5.0V

Outline

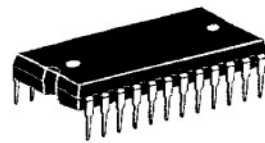

Outline 24P4 (AP)
 2.54mm pitch 600mil DIP
 (13.0mm X 31.1mm X 3.8mm)



Outline 24P2W-A(AFP)
 1.27mm pitch 450mil SOP
 (8.4mm X 15.0mm X 2.0mm)

SYSTEM CONFIGURATION

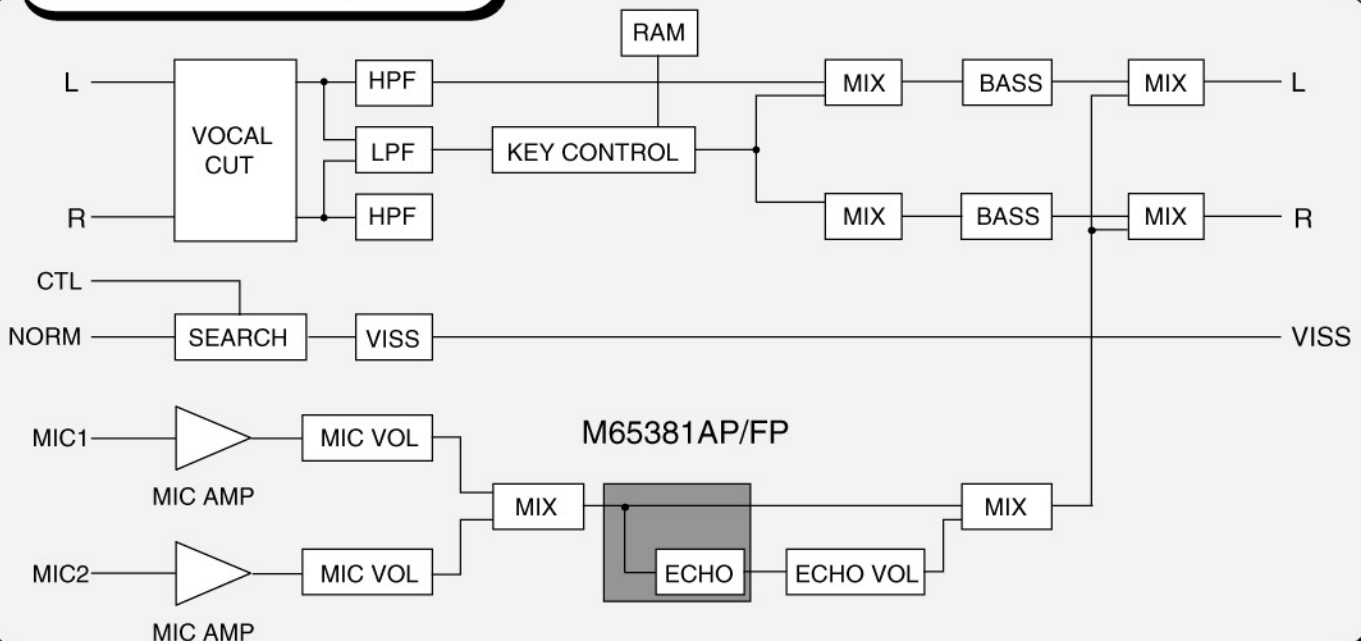

PRELIMINARY
Notice ; This is not a final specification.
some parametric limits are subject to change.

MITSUBISHI SOUND PROCESSOR ICs

M65831AP/FP

DIGITAL ECHO (DIGITAL DELAY)

Pin Configuration

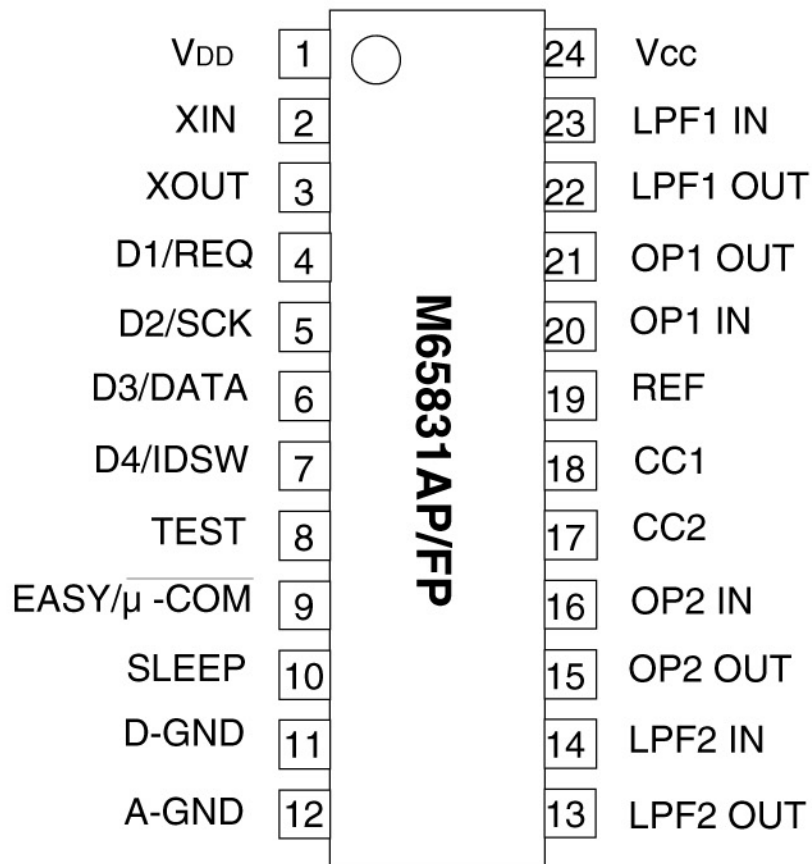

PRELIMINARY
 Notice ; This is not a final specification.
 some parametric limits are subject to change.

M65831AP/FP

DIGITAL ECHO (DIGITAL DELAY)

BLOCK DIAGRAM

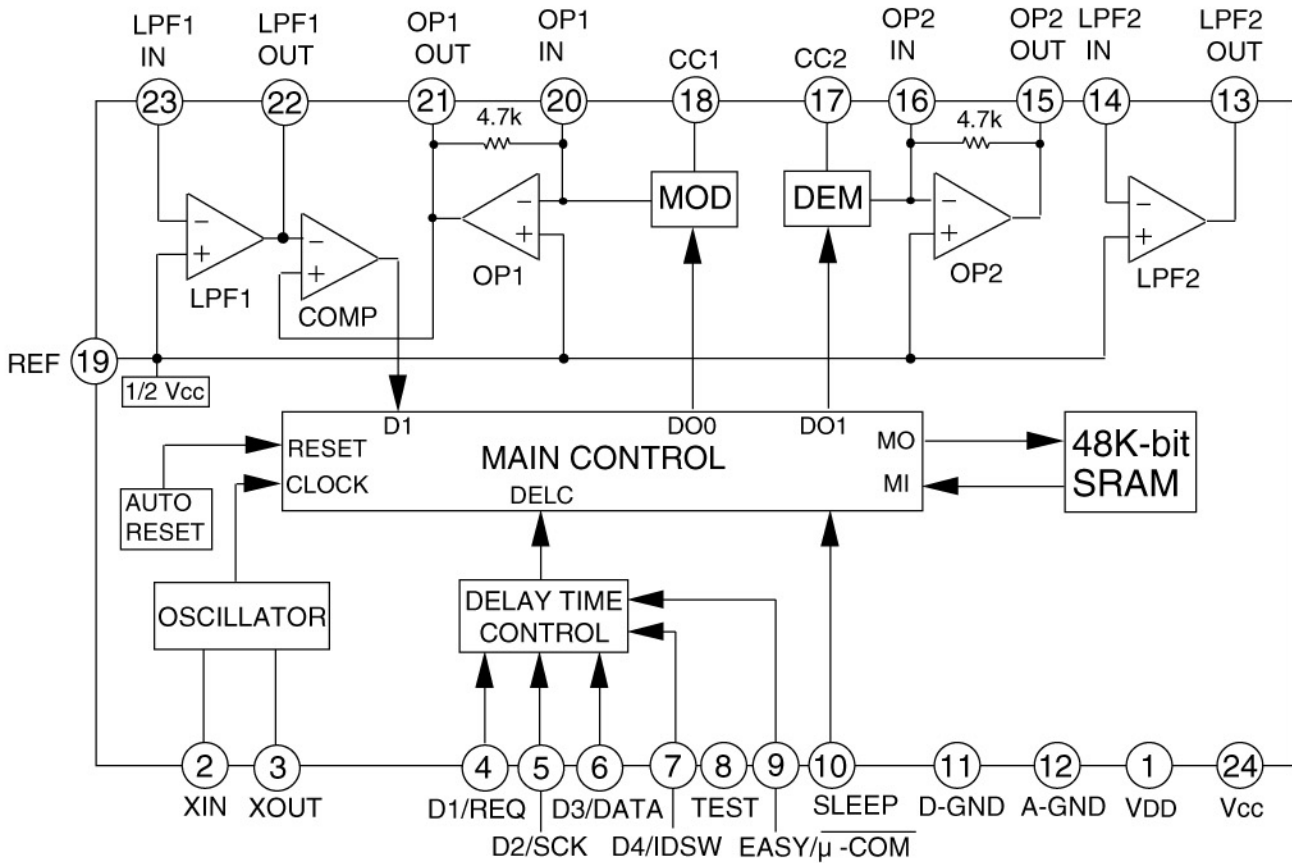

Unit Resistance:Ω

PRELIMINARY
 Notice ; This is not a final specification.
 some parametric limits are subject to change.

M65831AP/FP

DIGITAL ECHO (DIGITAL DELAY)

PIN DESCRIPTION

No.	Symbol	Name	I/O	Function
①	VDD	Digital VDD	—	Supply voltage
②	XIN	Oscillator input	I	
③	XOUT	Oscillator output	O	Connects to 2MHz ceramic filter
④	D1/REQ	Delay1/Request	I	Easy mode:inputs D1 data μ -COM mode:inputs request data
⑤	D2/SCK	Delay2/Shift clock	I	Easy mode:inputs D2 data μ -COM mode:inputs shift clock
⑥	D3/DATA	Delay3/Serial data	I	Easy mode:inputs D3 data μ -COM mode:inputs serial data
⑦	D4/IDSW	Delay4/ID switch	I	Easy mode:inputs D4 data μ -COM mode:controls ID code
⑧	TEST	Test	I	L=normal mode
⑨	EASY/ μ -COM	Easy/ μ -COM	I	H=easy mode L=μ -COM mode
⑩	SLEEP	Sleep	I	H=sleep mode L=normal mode
⑪	D GND	Digital GND	—	Connects to analog GND at one point
⑫	A GND	Analog GND	—	Connects to analog GND
⑬	LPF2 OUT	Low pass filter2 output	O	Forms low pass filter with external C.R
⑭	LPF2 IN	Low pass filter2 input	I	
⑮	OP2 OUT	OP-AMP2 output	O	Forms integrator with external C.R
⑯	OP2 IN	OP-AMP2 input	I	
⑰	CC2	Current control 2	—	
⑱	CC1	Current control 1	—	
⑲	REF	Reference	—	=1/2VCC
⑳	OP1 IN	OP-AMP1 input	I	Forms integrator with external C.R
㉑	OP1 OUT	OP-AMP1 output	O	
㉒	LPF1 OUT	Low pass filter1 output	O	Forms low pass filter with external C.R
㉓	LPF1 IN	Low pass filter1 input	I	
㉔	Vcc	Analog Vcc	—	Supply voltage

PRELIMINARY
 Notice ; This is not a final specification.
 some parametric limits are subject to change.

M65831AP/FP

DIGITAL ECHO (DIGITAL DELAY)

ABSOLUTE MAXIMUM RATINGS

(Vcc=5V, f=1kHz, Vi=100mVrms, Ta=25°C, unless otherwise noted)

Symbol	Parameter	Conditions	Ratings	Units
Vcc	Supply voltage		6.5	V
Icc	Circuit current		100	mA
Pd	Power dissipation	M65831AP	1	W
		M65831AFP	650	mW
Topr	Operating temperature		-20~+75	°C
Tstg	Storage temperature		-40~+125	°C

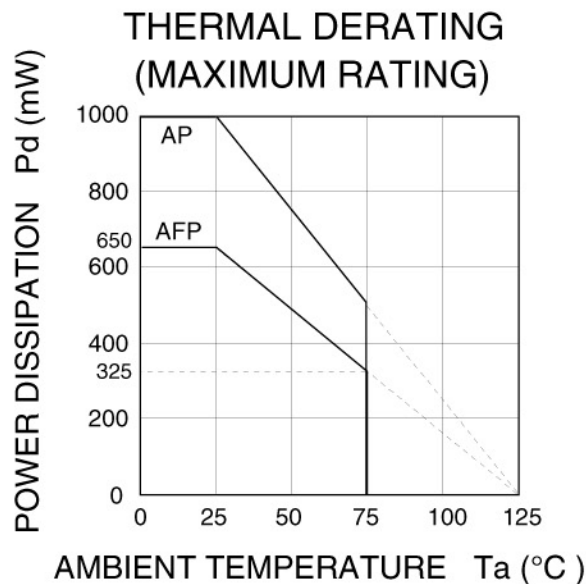

RECOMMENDED OPERATING CONDITIONS

Symbol	Parameter	Conditions	Limits			Units
			Min	Typ	Max	
Vcc	Supply voltage		4.5	5	5.5	V
VDD	Supply voltage		4.5	5	5.5	V
Vcc-VDD	Difference voltage		-0.3	0	0.3	V
fck	Clock frequency		1	2	3	MHz
VIH	High input voltage		0.7VDD		VDD	V
VIL	Low input voltage		0		0.3VDD	V

PRELIMINARY
 Notice ; This is not a final specification.
 some parametric limits are subject to change.

M65831AP/FP

DIGITAL ECHO (DIGITAL DELAY)

ELECTRICAL CHARACTERISTICS

(Vcc=5V, f=1kHz, Vi=100mVrms, Ta=25°C, unless otherwise noted)

Symbol	Parameter	Test conditions	Limits			Units	
			Min	Typ	Max		
Icc	Circuit current	No signal	—	18.0	40.0	mA	
Gv	Voltage gain	RL=47kΩ	-3.5	-0.5	2.5	dB	
Vomax	Maximum output voltage	THD=10%	0.7	1	—	Vrms	
THD	Output distortion	30kHz LPF	fs=500kHz	—	0.3	1.0	%
			fs=250kHz	—	0.5	1.5	
No	Output noise voltage	DIN-AUDIO (fs=250kHz)	—	-92	-75	dBV	
SVRR	Supply voltage rejection ratio	ΔVcc=-20dBV, f=100Hz	—	-40	-25	dB	
TMUTE	Mute time	Upon changing Delay Time	508	528	548	ms	
		Upon canceling Sleep Mode	508	528	548		
Iccs	Circuit current (Sleep mode)	Sleep Mode	—	14.0	30.0	mA	

PRELIMINARY
 Notice ; This is not a final specification.
 some parametric limits are subject to change.

M65831AP/FP

DIGITAL ECHO (DIGITAL DELAY)

OPERATION

1) DELAY TIME

D4	D3	D2	D1	fs	Td
L	L	L	L	500	12.3
			H		24.6
		H	L		36.9
			H		49.2
	H	L	L		61.4
			H		73.7
		H	L		86.0
			H		98.3
H	L	L	L	250	110.6
			H		122.9
		H	L		135.2
			H		147.5
	H	L	L		159.7
			H		172.0
		H	L		184.3
			H		196.6

fs=sampling frequency(kHz)
 Td=delay time(msec)

PRELIMINARY
 Notice ; This is not a final specification.
 some parametric limits are subject to change.

M65831AP/FP

DIGITAL ECHO (DIGITAL DELAY)

2) EASY MODE (EASY / $\overline{\mu\text{-COM}}=H$)

D1,D2,D3,D4 and sleep are for easy mode

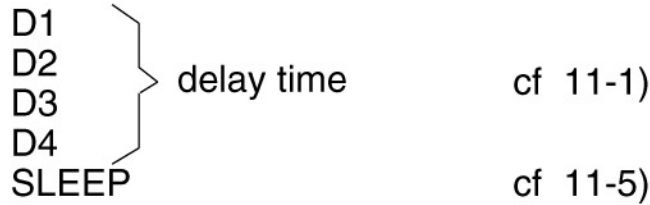

3) $\mu\text{-COM}$ MODE (EASY / $\overline{\mu\text{-COM}}=L$)

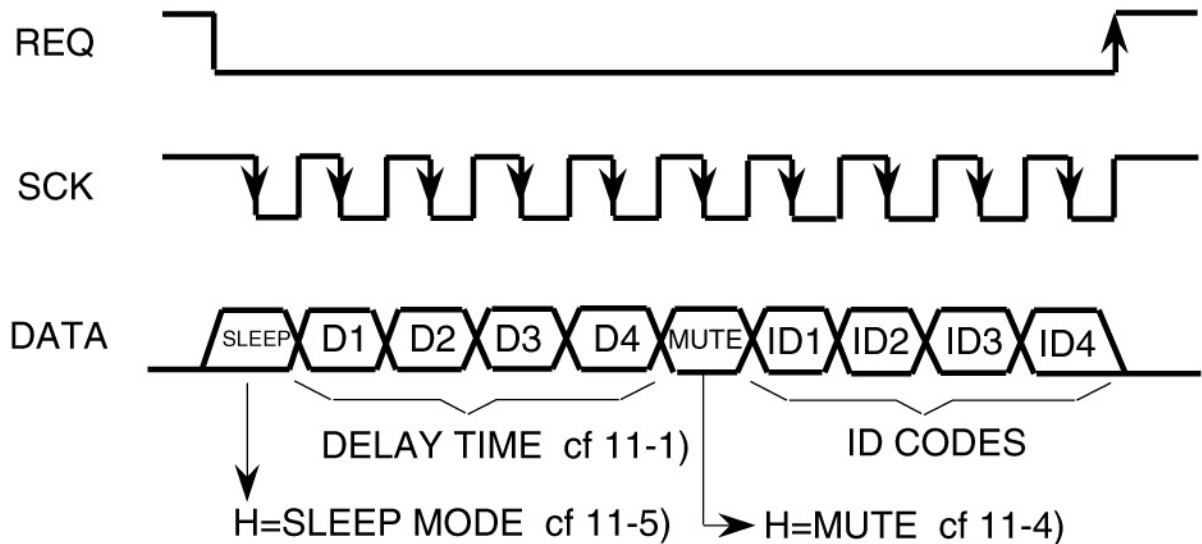

TIMING DIAGRAM

This Timing chart shows that delay time is set by serial data from $\mu\text{-COM}$.

DATA signal is latched at the falling edge of SCK signal, the last ten data are set at the rising edge of REQ signal when ID codes are satisfied. *

* { ID1, ID3: L
 ID2 : H
 ID4 : equal to IDSW

PRELIMINARY
 Notice ; This is not a final specification.
 some parametric limits are subject to change.

M65831AP/FP

DIGITAL ECHO (DIGITAL DELAY)

REQ,SCK,DATA INPUT TIMING

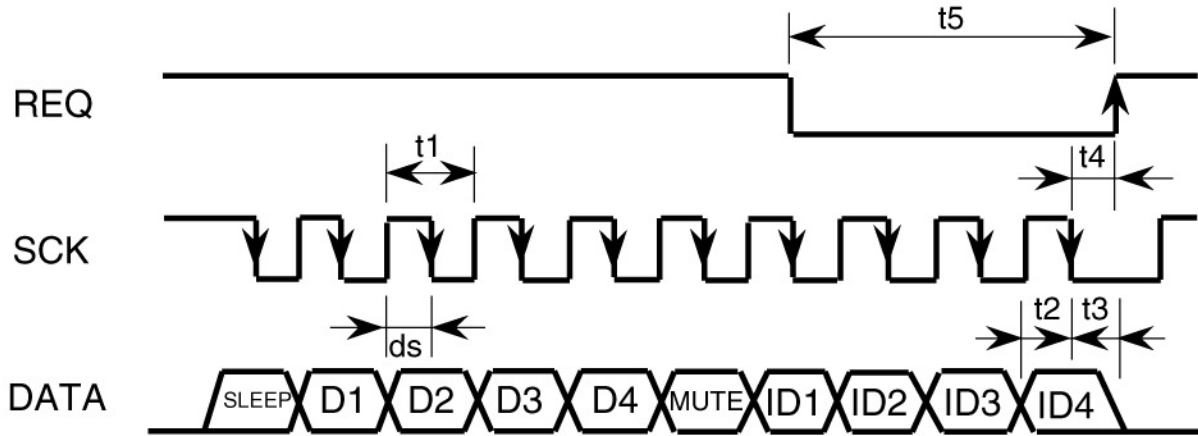

Symbol	Parameter	min	typ	max	Units
t_1	SCK pulse width	250	—	—	nsec
ds	SCK pulse duty	—	50	—	%
t_2	DATA setup time	100	$t_1/2$	—	nsec
t_3	DATA hold time	100	$t_1/2$	—	nsec
t_4	REQ hold time	100	—	—	nsec
t_5	REQ pulse width	250	—	—	nsec

PRELIMINARY
Notice ; This is not a final specification.
some parametric limits are subject to change.

M65831AP/FP

DIGITAL ECHO (DIGITAL DELAY)

4) MUTING

(1) Easy mode

Automatic mute upon changing delay time, cancelling SLEEP mode and power-on.

(2) μ -COM mode

MUTE=H:mute

MUTE=L:automatic mute

AUTOMATIC MUTE

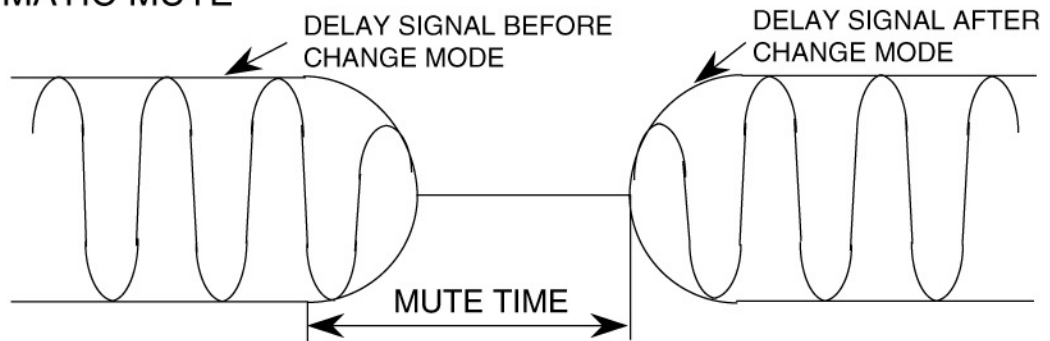

(a) UPON CHANGING DELAY TIME

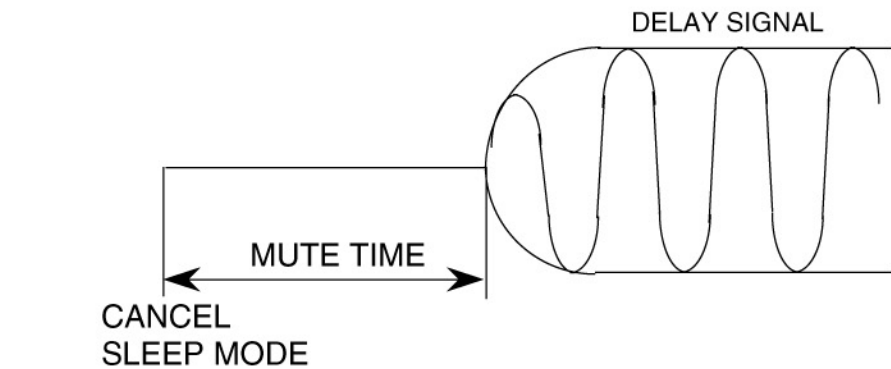

(b) UPON CANCELLING SLEEP MODE

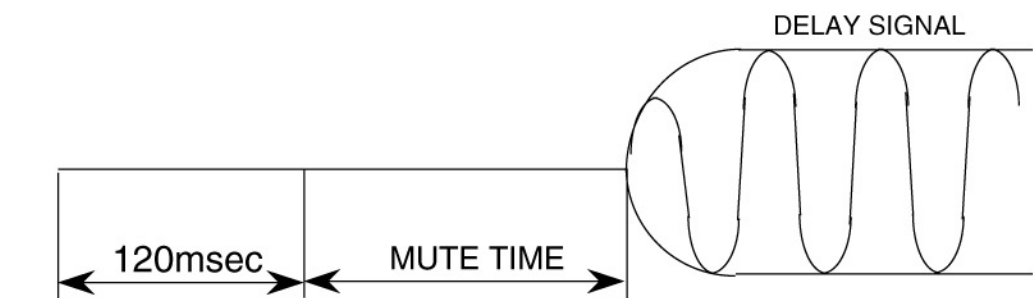

POWER ON

(c) UPON POWER-ON

PRELIMINARY
Notice ; This is not a final specification.
some parametric limits are subject to change.

MITSUBISHI SOUND PROCESSOR ICs

M65831AP/FP

DIGITAL ECHO (DIGITAL DELAY)

5) SLEEP MODE

SLEEP data is

(H:clock and RAM stop to reduce circuit current (SLEEP mode)
L:normal operation

6) SYSTEM RESET

Automatically reset power-on. The reset time is about 120msec.

Delay time is set at 147.5msec.

PRELIMINARY
 Notice ; This is not a final specification.
 some parametric limits are subject to change.

M65831AP/FP

DIGITAL ECHO (DIGITAL DELAY)

TEST CIRCUIT

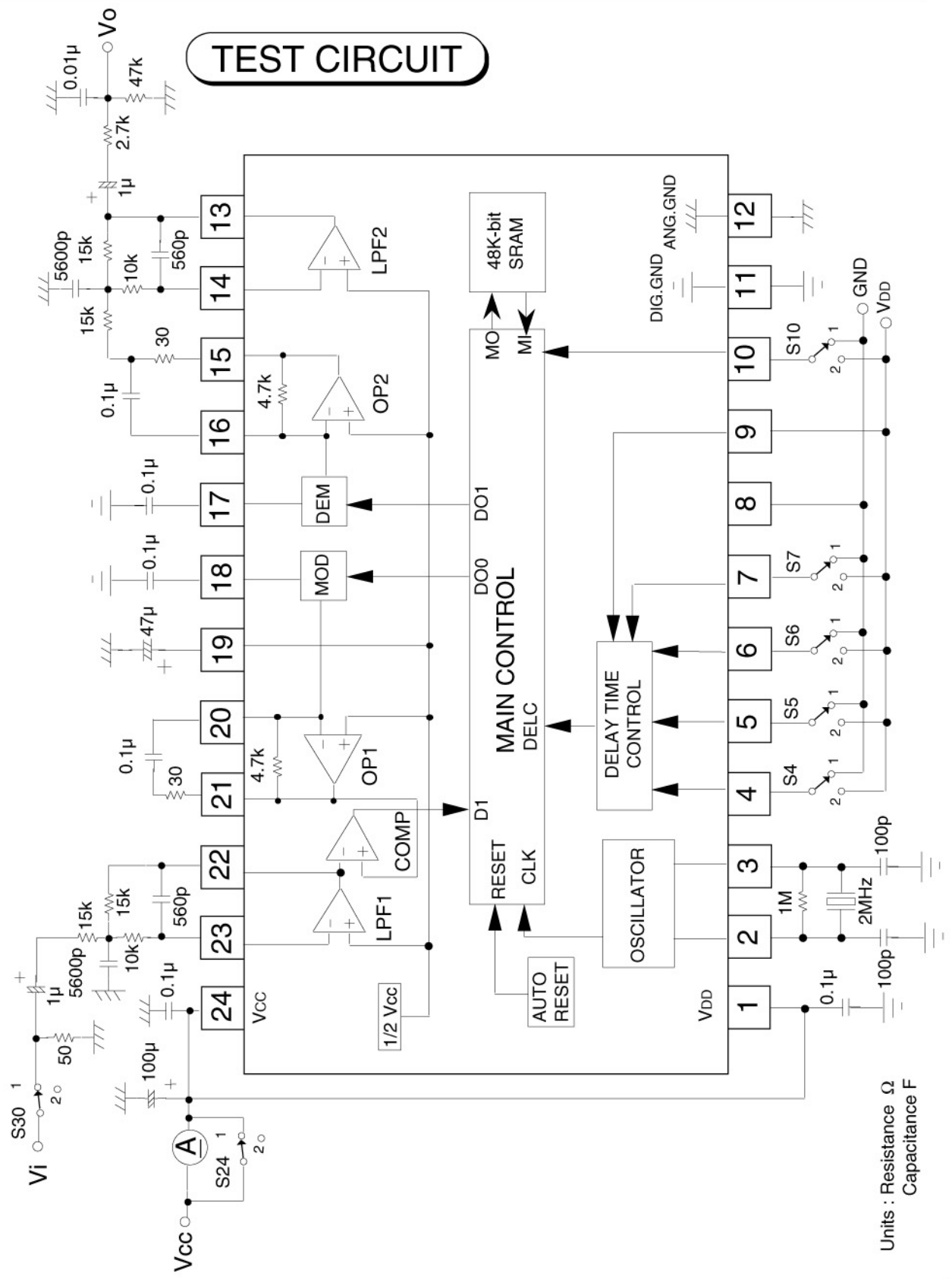

Units : Resistance Ω
 Capacitance F

PRELIMINARY
 Notice ; This is not a final specification.
 some parametric limits are subject to change.

M65831AP/FP

DIGITAL ECHO (DIGITAL DELAY)

TEST METHODS

Switch condition

* 1 or 2

No	Parameter	Sampling frequency	Symbol	S 4	S 5	S 6	S 7	S 10	S 24	S 30	notes
1	Current circuit	—	Icc	1	1	1	1	1	2	2	No signal
2	Voltage gain	500kHz	Gv1	*	*	*	1	1	1	1	
		250kHz	Gv2	*	*	*	2	1	1	1	
3	Delay time	500kHz	Tda	1	1	1	1	1	1	1	cf. 11-1)
			Tdb	2	1	1	1	↓	↓	↓	
			Tdc	1	2	1	1	↓	↓	↓	
			Tdd	2	2	1	1	↓	↓	↓	
			Tde	1	1	2	1	↓	↓	↓	
			Tdf	2	1	2	1	↓	↓	↓	
			Tdg	1	2	2	1	↓	↓	↓	
		250kHz	Tdh	2	2	2	1	↓	↓	↓	
			Tdi	1	1	1	2	↓	↓	↓	
			Tdj	2	1	1	2	↓	↓	↓	
			Tdk	1	2	1	2	↓	↓	↓	
			Tdl	2	2	1	2	↓	↓	↓	
			Tdm	1	1	2	2	↓	↓	↓	
			Tdn	2	1	2	2	↓	↓	↓	
Tdo	1	2	2	2	↓	↓	↓				
Tdp	2	2	2	2	1	1	1				
4	Output voltage (max)	500kHz	Vomax 1	*	*	*	1	1	1	1	30kHz L.P.F. THD=10%
		250kHz	Vomax 2	*	*	*	2	1	1	1	
5	Total harmonic distortion	500kHz	THD 1	*	*	*	1	1	1	1	30kHz L.P.F.
		250kHz	THD 2	*	*	*	2	1	1	1	
6	Output noise voltage	250kHz	No	*	*	*	2	1	1	1	DIN AUDIO Vi=0mVrms
7	Supply voltage rejection ratio	—	SVRR	*	*	*	*	1	1	2	ΔVcc=-20dBv, f=100Hz
8	Mute time	—	MUTE T	² ↓ ₁	*	*	*	1	1	1	Upon changing Delay Time
		—	MUTE S	*	*	*	*	² ↓ ₁	1	1	Upon cancelling Sleep Mode

PRELIMINARY
 Notice ; This is not a final specification.
 some parametric limits are subject to change.

M65831AP/FP

DIGITAL ECHO (DIGITAL DELAY)

APPLICATION EXAMPLE

1.EASY MODE

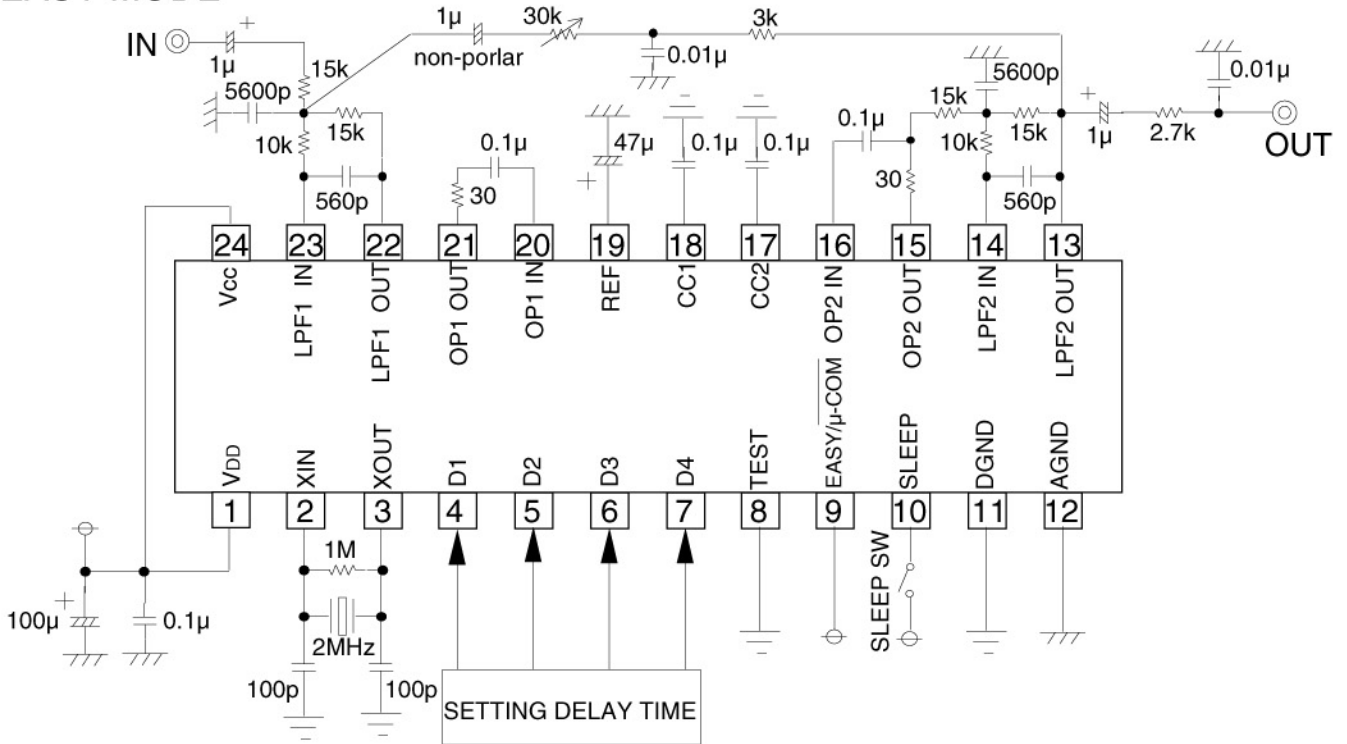

2.µ -COM MODE

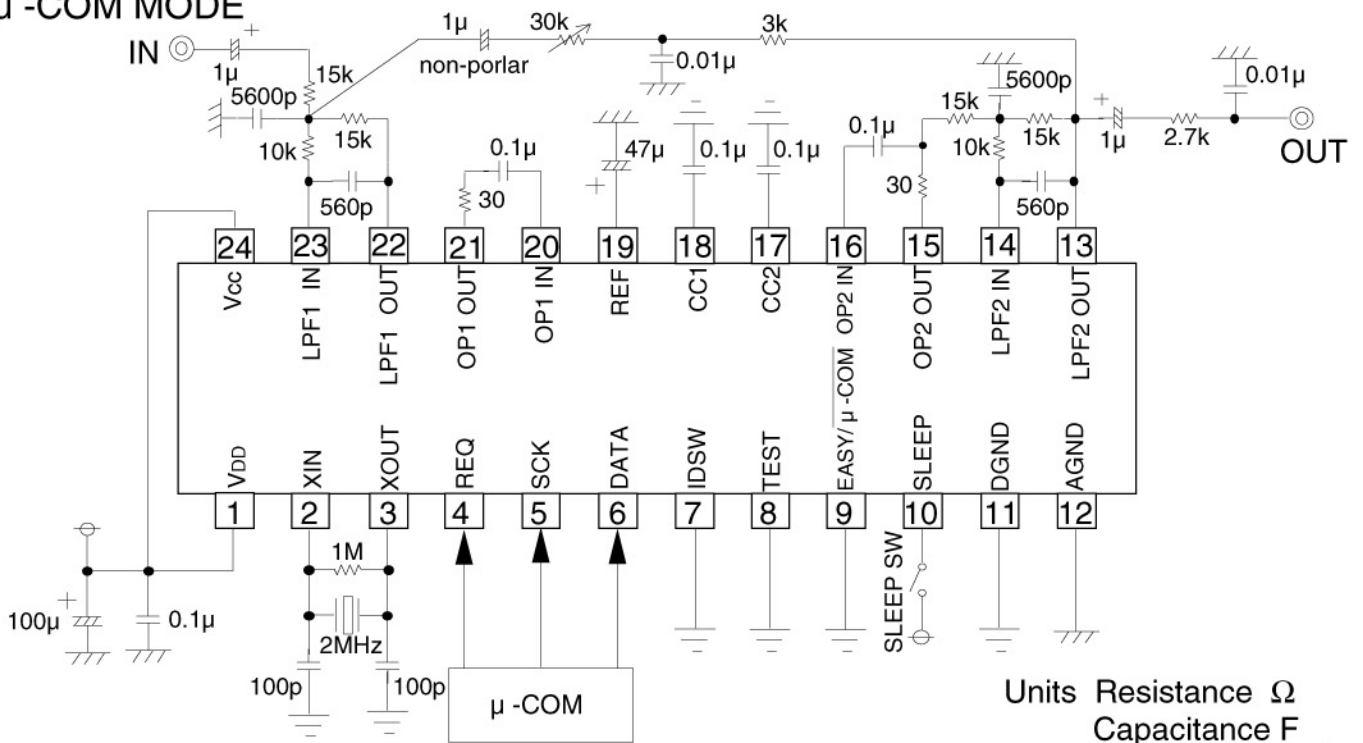

Units Resistance Ω
 Capacitance F