

2-INPUT AND GATE

The KIC7SH08FU is a advanced high speed C²MOS 2-INPUT AND GATE fabricated with silicon gate C²MOS technology. It achieves the high speed operation similar to equivalent Bipolar Schottky TTL while maintaining the C²MOS low power dissipation. The internal circuit is composed of 4 stage including buffer output, which provide high noise immunity and stable output. An input protection circuit ensures that 0 to 7V can be applied to the input pins without regard to the supply voltage. This device can be used to interface 5V to 3V systems and two supply systems such as battery back up. This circuit prevents device destruction due to mismatched supply and input voltages.

FEATURES

- High Speed : $t_{pd}=4.3ns(Typ.)$ at $V_{CC}=5V$.
- Low Power Dissipation : $I_{CC}=2 \mu A(Max.)$ at $T_a=25$
- High Noise Immunity : $V_{NIH}=V_{NIL}=28\% V_{CC}(Min.)$.
- Power Down Protection is Provided on all inputs.
- Balanced Propagation Delays : $t_{pLH} \approx t_{pHL}$
- Wide Operating Voltage Range : $V_{CC(opr)}=2 \sim 5.5V$.

MAXIMUM RATINGS (Ta=25)

| CHARACTERISTIC | SYMBOL | RATING | UNIT |
|-----------------------------|-----------|-------------------|------|
| Supply Voltage Range | V_{CC} | -0.5 7.0 | V |
| DC Input Voltage | V_{IN} | -0.5 7.0 | V |
| DC Output Voltage | V_{OUT} | -0.5 $V_{CC}+0.5$ | V |
| Input Diode Current | I_{IK} | -20 | mA |
| Output Diode Current | I_{OK} | ± 20 | mA |
| DC Output Current | I_{OUT} | ± 25 | mA |
| DC V_{CC} /Ground Current | I_{CC} | ± 50 | mA |
| Power Dissipation | P_D | 200 | mW |
| Storage Temperature | T_{stg} | -65 150 | |
| Lead Temperature (10s) | T_L | 260 | |

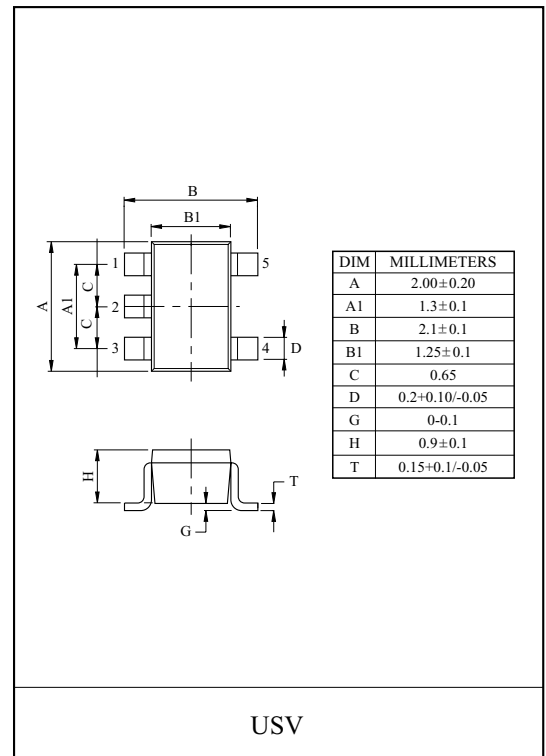

MARKING

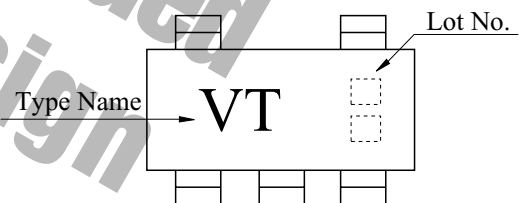

PIN CONNECTION (TOP VIEW)

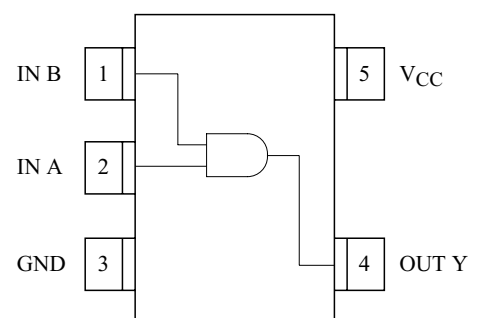

KIC7SH08FU

LOGIC DIAGRAM

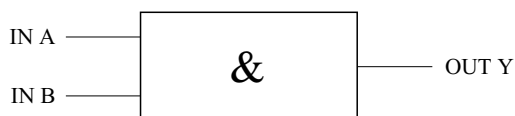

TRUTH TABLE

| A | B | Y |
|---|---|---|
| L | L | L |
| L | H | L |
| H | L | L |
| H | H | H |

RECOMMENDED OPERATING CONDITIONS

| CHARACTERISTIC | SYMBOL | RATING | UNIT |
|--------------------------|------------|---------------------------------|------|
| Supply Voltage | V_{CC} | 2.0 5.5 | V |
| Input Voltage | V_{IN} | 0 5.5 | V |
| Output Voltage | V_{OUT} | 0 V_{CC} | V |
| Operating Temperature | T_{opr} | -40 85 | |
| Input Rise and Fall Time | t_r, t_f | 0 100 ($V_{CC}=3.3 \pm 0.3V$) | ns |
| | | 0 20 ($V_{CC}=5 \pm 0.5V$) | |

DC ELECTRICAL CHARACTERISTICS

| CHARACTERISTIC | SYMBOL | TEST CONDITION | Ta=25 | | | Ta=-40 85 | | UNIT | | |
|---------------------------|----------|------------------------|--------------------------------|---------------------|------|---------------------|---------------------|---------------------|---------|---|
| | | | V_{CC} | MIN. | TYP. | MAX. | MIN. | | MAX. | |
| High-Level Input Voltage | V_{IH} | - | 2.0 | 1.50 | - | - | 1.50 | - | V | |
| | | | 3.0 | $V_{CC} \times 0.7$ | - | - | $V_{CC} \times 0.7$ | - | | |
| | | | 5.5 | $V_{CC} \times 0.7$ | - | - | $V_{CC} \times 0.7$ | - | | |
| Low-Level Input Voltage | V_{IL} | - | 2.0 | - | - | 0.50 | - | 0.50 | V | |
| | | | 3.0 | - | - | $V_{CC} \times 0.3$ | - | $V_{CC} \times 0.3$ | | |
| | | | 5.5 | - | - | $V_{CC} \times 0.3$ | - | $V_{CC} \times 0.3$ | | |
| High-Level Output Voltage | V_{OH} | $V_{IN}=V_{IL}$ | $I_{OH}=-50 \mu A$ | 2.0 | 1.9 | 2.0 | - | 1.9 | - | V |
| | | | | 3.0 | 2.9 | 3.0 | - | 2.9 | - | |
| | | | | 4.5 | 4.4 | 4.5 | - | 4.4 | - | |
| | | $V_{IN}=GND$ | $I_{OH}=-4mA$ $I_{OH}=-8mA$ | 3.0 | 2.58 | - | - | 2.48 | - | |
| | | | | 4.5 | 3.94 | - | - | 3.80 | - | |
| | | | | | | | | | | |
| Low-Level Output Voltage | V_{OL} | $V_{IN}=V_{IH}$ | $I_{OL}=50 \mu A$ | 2.0 | - | 0.0 | 0.1 | - | 0.1 | V |
| | | | | 3.0 | - | 0.0 | 0.1 | - | 0.1 | |
| | | | | 4.5 | - | 0.0 | 0.1 | - | 0.1 | |
| | | $V_{IN}=V_{CC}$ | $I_{OL}=4mA$ $I_{OL}=8mA$ | 3.0 | - | - | 0.36 | - | 0.44 | |
| | | | | 4.5 | - | - | 0.36 | - | 0.44 | |
| | | | | | | | | | | |
| Input Leakage Current | I_{IN} | $V_{IN}=5.5V$ or GND | 0 5.5 | - | - | ± 0.1 | - | ± 1.0 | μA | |
| Quiescent Supply Current | I_{CC} | $V_{IN}=V_{CC}$ or GND | 5.5 | - | - | 2.0 | - | 20.0 | | |

KIC7SH08FU

AC ELECTRICAL CHARACTERISTICS (Input $t_r=t_f=3ns$)

| CHARACTERISTIC | SYMBOL | TEST CONDITION | | | Ta=25 | | | Ta=-40 85 | | UNIT |
|-------------------------------|-----------------|----------------|---------------------|---------------------|-------|------|------|-----------|------|------|
| | | | V _{CC} (V) | C _L (pF) | MIN. | TYP. | MAX. | MIN. | MAX. | |
| Propagation Delay Time | t_{PLH} | - | 3.3 ± 0.3 | 15 | - | 6.2 | 8.8 | 1.0 | 10.5 | ns |
| | | | | 50 | - | 8.7 | 12.3 | 1.0 | 14.0 | |
| | t_{PHL} | | 5.0 ± 0.5 | 15 | - | 4.3 | 5.9 | 1.0 | 7.0 | |
| | | | | 50 | - | 5.8 | 7.9 | 1.0 | 9.0 | |
| Input Capacitance | C _{IN} | - | - | 4 | 10 | - | 10 | pF | | |
| Power Dissipation Capacitance | C _{PD} | (Note 1) | - | 14 | - | - | - | - | pF | |

Note 1 : C_{PD} defined as the value of the internal equivalent capacitance which is calculated from the operating current consumption without load average operating current can be obtained by the equation hereunder.

$$I_{CC(opr)} = C_{PD} \cdot V_{CC} \cdot f_{IN} + I_{CC}$$

INPUT EQUIVALENT CIRCUIT

