

Dwg. No.		01240	
REV	DESCRIPTION	BY DATE	APPD
C	ECN 2267	7/4/00	<i>[Signature]</i>

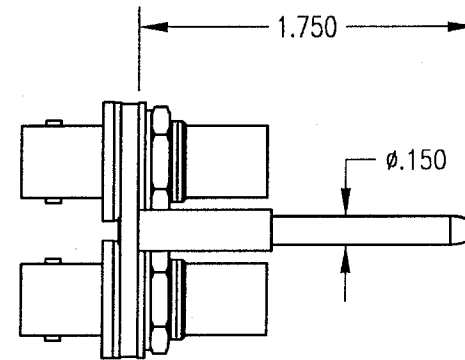
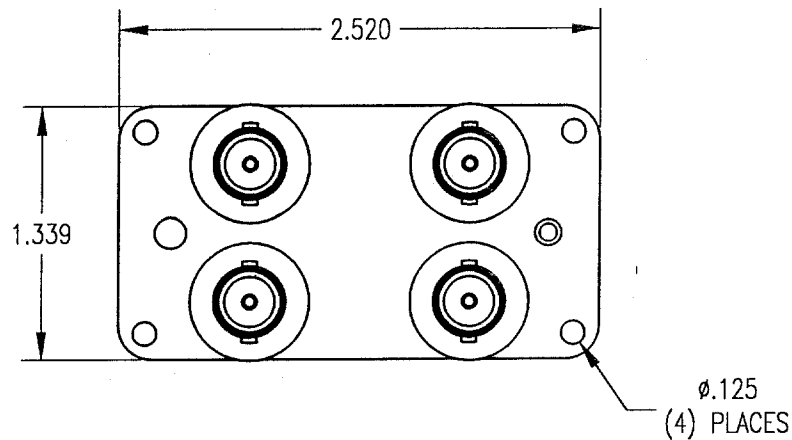
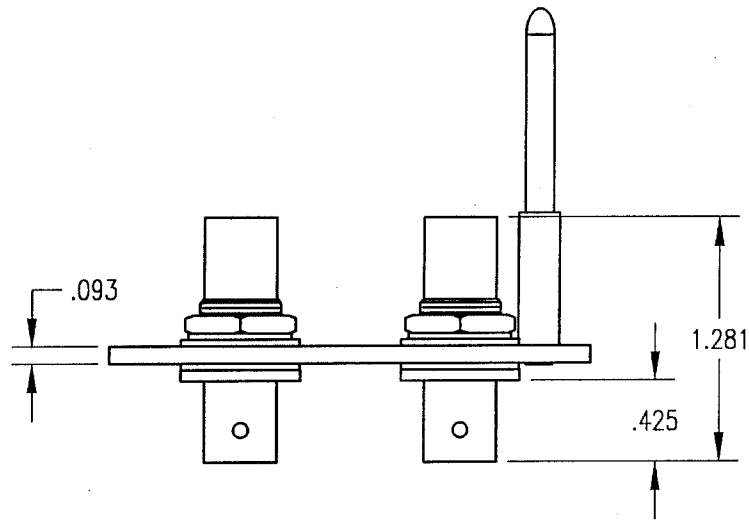

NOTES:

1. MATERIALS:

PLATE: ALUMINUM ALLOY 6061-T6 PER ASTM B209
 GUIDE PIN: STAINLESS STEEL PER ASTM A582
 BNC JACK ADAPTER: SEE SALES DRAWING 611-611-2401N

2. FINISH:

PLATE: ANODIZED PER MIL-A-8625
 GUIDE PIN: PASSIVATED PER QQ-P-35
 BNC JACK ADAPTER: SEE SALES DRAWING 611-611-2401N

PER ASME Y14.5M-1994 UNLESS OTHERWISE SPECIFIED: DIMENSIONS ARE IN INCHES (MM)		Littón	
TOLERANCES: DECIMALS .XX ± .01/0.254 XXX ± .005/0.127 ANGLES ± 2°		400 Park Road Waterbury, Connecticut 06795	
SCALE: 1:1		TITLE	
CUSTOMER DRAWING		BNC JACK TO BNC SPECIAL JACK 75 OHM FEED THRU ADAPTER	
DRAWN JED	DATE 2/14/00	CHECKED <i>[Signature]</i>	DATE 4/4/00
APPROVED <i>[Signature]</i>	DATE 2/1/00	APPROVED <i>[Signature]</i>	DATE 4/3/00
A	01240	SHT. OF	1 1
		REV.	C