

# GD54/74HC280, GD54/74HCT280

## 9-BIT EVEN/ODD PARITY GENERATOR/CHECKER

### General Description

These devices are identical in pinout to the 54/74LS280. They contain 9-bit inputs and 2 outputs (even and odd parities) to facilitate operation of either even or odd parity applications. Words of greater than 9 bits can be accommodated by cascading other HC/HCT 280 devices. These devices are characterized for operation over wide temperature ranges to meet industry and military specifications.

### Features

- Low Power consumption characteristic of CMOS devices
- Output drive capability: 10 LS TTL Loads Min.
- Operating speed superior to LS TTL
- Wide operating voltage range: for HC 2 to 6 volts  
for HCT 4.5 to 5.5 volts
- Low input current: 1 $\mu$ A Max.
- Low quiescent current: 80 $\mu$ A Max. (74HC)
- High noise immunity characteristic of CMOS
- Diode protection on all inputs

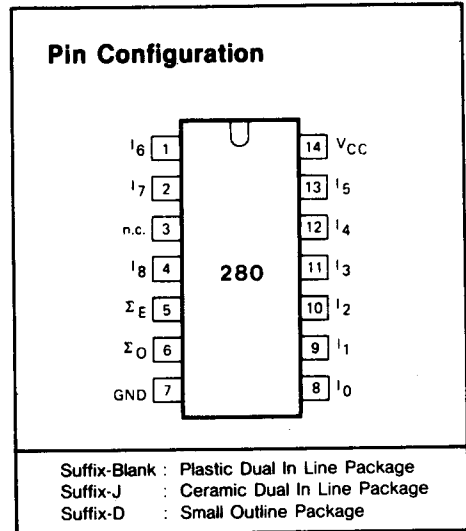

### Function Table

INPUTS	OUTPUTS	
number of HIGH data inputs (I <sub>0</sub> to I <sub>8</sub> )	$\Sigma_E$	$\Sigma_O$
even	H	L
odd	L	H

H=HIGH voltage level  
L=LOW voltage level

**Absolute Maximum Ratings**

SYMBOL	PARAMETER	CONDITIONS	MIN.	MAX.	UNIT
$V_{CC}$	DC Supply voltage		-0.5	+7	V
$I_{IK}, I_{OK}$	DC input or output diode current	for $V_I < -0.5$ or $V_I > V_{CC} + 0.5V$		20	mA
$I_O$	DC output source or sink current	for $-0.5V < V_O < V_{CC} + 0.5V$		25	mA
$I_{CC}$	DC $V_{CC}$ or GND current			50	mA
$T_{stg}$	Storage temperature range		-65	150	°C
$P_D$	Power dissipation per package	above +70°C: derate linearly with 8mW/K		500	mW
$T_L$	Lead temperature	At distance $1/16 \pm 1/32$ in. from case for 60 sec(CERAMIC) 10 sec(PLASTIC)		300 260	°C

**Recommended Operating Conditions**

CHARACTERISTIC	LIMITS		UNITS
	MIN.	MAX.	
Supply-Voltage Range $V_{CC}$ : GD54/74HC Types GD54/74HCT Types	2 4.5	6 5.5	V
DC Input or Output Voltage $V_I, V_O$	0	$V_{CC}$	V
Operating Temperature $T_A$ : GD74 Types GD54 Types	-40 -55	+85 +125	°C
Input Rise and Fall times $t_r, t_f$ : GD54/74HC Types at 2V at 4.5V at 6V GD54/74HCT Types at 4.5V		1000 500 400 500	ns

**Logic Diagram**

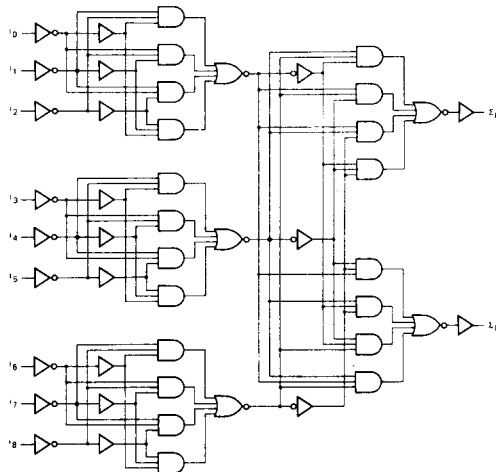

Fig. 1 Logic diagram

DC Electrical Characteristics for HC

SYMBOL	PARAMETER	TEST CONDITION	V <sub>CC</sub> (V)	T <sub>A</sub> =25°C			GD74HC280		GD54HC280		UNIT	
				MIN.	TYP.	MAX.	MIN.	MAX.	MIN.	MAX.		
V <sub>IH</sub>	HIGH level input Voltage		2.0	1.5			1.5		1.5		V	
			4.5	3.15			3.15		3.15			
			6.0	4.2			4.2		4.2			
V <sub>IL</sub>	LOW level input voltage		2.0			0.3		0.3		0.3	V	
			4.5			0.9		0.9		0.9		
			6.0			1.2		1.2		1.2		
V <sub>OH</sub>	HIGH level output voltage	V <sub>IN</sub> =V <sub>IH</sub>	I <sub>OH</sub> =-20μA	2.0	1.9	2.0		1.9		1.9	V	
				4.5	4.4	4.5		4.4		4.4		
				6.0	5.9	6.0		5.9		5.9		
		or V <sub>IL</sub>	I <sub>OH</sub> =-4mA I <sub>OH</sub> =-5.2mA	4.5	3.98	4.3		3.84		3.7		
				6.0	5.48	5.2		5.34		5.2		
V <sub>OL</sub>	LOW level output voltage	V <sub>IN</sub> =V <sub>IH</sub>	I <sub>OL</sub> =20μA	2.0			0.1		0.1		V	
				4.5			0.1		0.1			0.1
				6.0			0.1		0.1			0.1
		or V <sub>IL</sub>	I <sub>OL</sub> =4mA I <sub>OL</sub> =5.2mA	4.5		0.17	0.26		0.33			0.4
				6.0		0.15	0.26		0.33			0.4
I <sub>IN</sub>	Input leakage Current	V <sub>IN</sub> =V <sub>CC</sub> or GND	6.0			0.1		1.0		1.0	μA	
I <sub>CC</sub>	Quiescent Supply Current	V <sub>IN</sub> =V <sub>CC</sub> or GND I <sub>out</sub> =0μA	6.0			8		80		160	μA	

DC Electrical Characteristics for HCT

SYMBOL	PARAMETER	TEST CONDITION	V <sub>CC</sub> (V)	T <sub>A</sub> =25°C			GD74HCT280		GD54HCT280		UNIT
				MIN.	TYP.	MAX.	MIN.	MAX.	MIN.	MAX.	
V <sub>IH</sub>	HIGH level input Voltage		4.5 to 5.5	2.0			2.0		2.0		V
V <sub>IL</sub>	LOW level input voltage		4.5 to 5.5			0.8		0.8		0.8	V
V <sub>OH</sub>	HIGH level output voltage	V <sub>IN</sub> =V <sub>IH</sub>	I <sub>OH</sub> =-20μA	4.5	4.4	4.5		4.4		4.4	V
				4.5	3.98	4.3		3.84		3.7	
		or V <sub>IL</sub>	I <sub>OH</sub> =-4mA	4.5							
V <sub>OL</sub>	LOW level output voltage	V <sub>IN</sub> =V <sub>IH</sub>	I <sub>OL</sub> =20μA	4.5			0.1		0.1		V
				4.5		0.17	0.26		0.33		
		or V <sub>IL</sub>	I <sub>OL</sub> =4mA	4.5							
I <sub>IN</sub>	Input leakage Current	V <sub>IN</sub> =V <sub>CC</sub> or GND	5.5			0.1		1.0		1.0	μA
I <sub>CC</sub>	Quiescent Supply Current	V <sub>IN</sub> =V <sub>CC</sub> or GND I <sub>out</sub> =0μA	5.5			8		80		160	μA

AC Characteristics for HC:  $t_r=t_f=6\text{ns}$   $C_L=50\text{ pF}$

SYMBOL	PARAMETER	$V_{CC}$ (V)	$T_A=25^\circ\text{C}$			GD74HC280		GD54HC280		UNIT
			MIN.	TYP.	MAX.	MIN.	MAX.	MIN.	MAX.	
$t_{PLH}$ / $t_{PHL}$	Propagation Delay Time I to $\Sigma_E$	2.0		50	160		210		260	ns
		4.5		18	35		42		50	
		6.0		16	30		38		40	
$t_{PLH}$ / $t_{PHL}$	Propagation Delay Time I to $\Sigma_O$	2.0		60	180		230		280	ns
		4.5		20	38		50		58	
		6.0		18	32		42		49	
$t_{TLH}$ / $t_{THL}$	Output Transition Time	2.0		25	70		85		100	ns
		4.5		8	15		18		22	
		6.0		7	13		16		19	

AC Characteristics for HCT:  $t_r=t_f=6\text{ns}$   $C_L=50\text{ pF}$

SYMBOL	PARAMETER	$V_{CC}$ (V)	$T_A=25^\circ\text{C}$			GD74HCT280		GD54HCT280		UNIT
			MIN.	TYP.	MAX.	MIN.	MAX.	MIN.	MAX.	
$t_{PLH}$ / $t_{PHL}$	Propagation Delay Time I to $\Sigma_E$	4.5		20	38		46		55	ns
$t_{PLH}$ / $t_{PHL}$	Propagation Delay Time I to $\Sigma_O$	4.5		22	40		52		60	ns
$t_{TLH}$ / $t_{THL}$	Output Transition Time	4.5		8	15		18		22	ns

AC Waveform

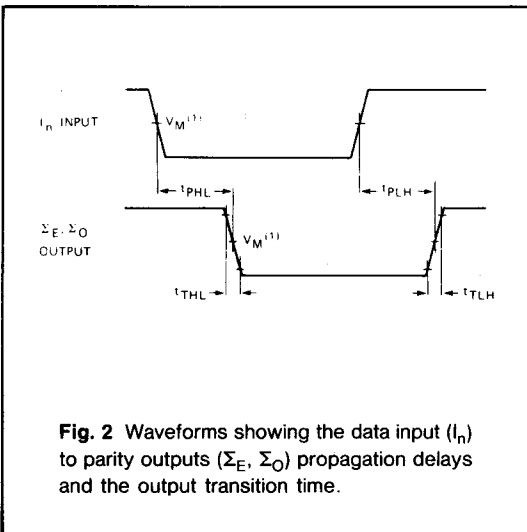

Fig. 2 Waveforms showing the data input ( $I_n$ ) to parity outputs ( $\Sigma_E, \Sigma_O$ ) propagation delays and the output transition time.

Note to AC waveform

- (1) HC :  $V_M=50\%$ ;  $V_I=GND$  to  $V_{CC}$ .
- HCT:  $V_M=1.3\%$ ;  $V_I=GND$  to 3V.