

C467D Issue 1 May 1989

Features

- MIL-STD-1750A Instruction Set Architecture
- Full Performance over Military Temperature Range
- 12-Bit Microsequencer
 - Instruction Prefetch
 - Pipelined Operation
 - Subroutine Capability
- On-Chip ROM
 - 2K x 40-Bit Microcode Store
 - 512 x 8-Bit Instruction Map
- MAS281 Integrated Built-in Self Test
- TTL Compatible System Interface
- Low Power CMOS/SOS Technology

Block Diagram

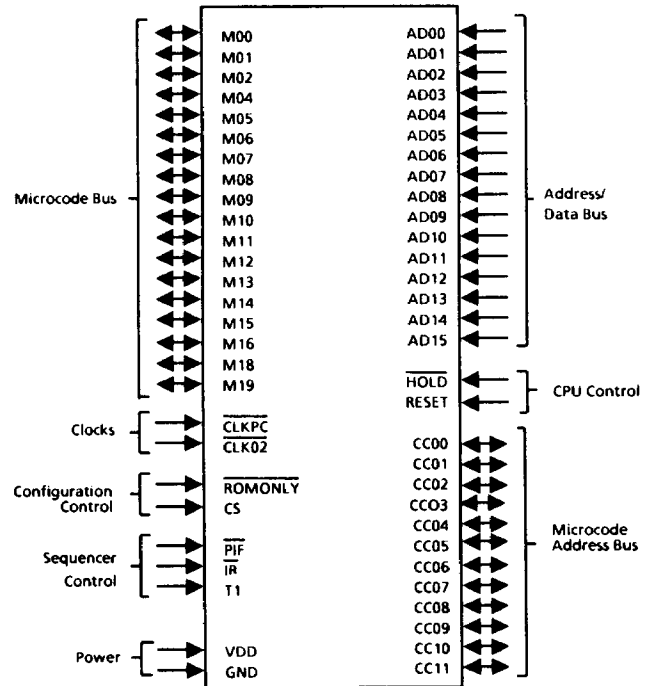

Product Description

The MA17502 Control Unit is a component of the Marconi Electronic Devices MAS281 chip set. Other chips in the set include the MA17501 Execution Unit and the MA17503 Interrupt Unit. Also available is the peripheral MA17504 Memory Management Unit/Block Protection Unit. In conjunction these chips implement the full MIL-STD-1750A Instruction Set Architecture.

The MA17502 - consisting of a microsequencer, a microcode storage ROM, and an instruction mapping ROM - controls all chip set operations. Table 1 provides brief signal definitions.

The MA17502 is offered in several speed and screening grades, and in dual in-line, flatpack or leadless chip carrier packaging. Screening options are described in this document. For availability of speed grades, please contact Marconi Electronic Devices.

The information presented herein is to the best of our knowledge true and accurate. No warranty expressed or implied is made regarding the capacity, performance or suitability of any product. You are strongly urged to ensure that the information given has not been superseded by a more up to date version.

Marconi Circuit Technology Corporation

45 Davids Drive, Hauppauge, New York 11788
(516) 231-7710/FAX: (516) 231-7923

Regional Offices: Central - (317) 463-5255 Western - (714) 894-9313

Signature	I/O	Definition
AD00 - AD15	I	External 16-Bit Address/Data Bus
CC00 - CC11	I/O	12-Bit Microcode Address Bus
CLKPC	I	Precharge Clock
CLK02	I	Phase 2 Clock
CS	I	Chip Select
HOLD	I	Hold Request Suspends Internal Processor Functions
IR	I	Interrupt Request
M00 - M19	I/O/Z	20-Bit Microcode Bus
NC	-	No Connection
PIF	I	Privileged Instruction Fault
RESET	I	Rest Indicates Device Initialization
ROMONLY	I	Indicates if Control Unit to be Used as ROM Only
T1	I	Branch or Jump Control
VDD		Power (External), 5 Volts
GND		Ground

Table 1. Signal Definitions

As shown in Figure 1, the MAS281 is the minimum processor configuration consisting of an Execution Unit, a Control Unit, and an Interrupt Unit. This configuration is capable of accessing a 64K-word address space. Addition of an MMU configured MA17504 allows access to a 1M-word address space. Addition of a BPU configured MA17504 provides hardware support for 1K-word memory block write protection.

The CU, as with all components of the MAS281 chip set, is fabricated with Marconi Electronic Devices' CMOS/SOS process technology. Input and output buffers associated with signals external to the MAS281 are TTL compatible.

Detailed descriptions of the CU's companion chips are provided in separate data sheets. Additional discussions on chip set system considerations, interconnection details, and the Digital Avionics Instruction Set (DAIS) mix benchmarking analysis are provided in separate applications notes.

**Radiation Hard
MIL-STD-1750A
Control Unit****2.0 Architecture**

The Control Unit consists of a microsequencer, an instruction mapping ROM, a microcode storage ROM, and various buses. Details of these components are shown in Figure 2 and are discussed below:

2.1 Microsequencer

The CU microsequencer is a 12-bit wide microcode address generator. Major features of the microsequencer include a microprogram counter (PC), a microprogram counter save register (PC Save), microcode address increment logic, instruction pipeline registers IA and IB, an iteration of loop counter, a next microcode address source multiplexer, and various pipelining latches. These features are represented in Figure 2.

The 12-bit microcode address width allows the microsequencer to access up to 4096 words of microcode. The MIL-STD-1750A instructions are implemented as sequences of microinstructions stored within the lower 2048 locations of this address space. The address for each microinstruction in a sequence is provided by the next microcode address source multiplexer. This multiplexer, under control of the CU control logic, select from one of six next address sources. Sequential, direct jump, conditional jump, and subroutine address generation modes are supported.

Sequential addressing is accomplished by providing a path from the output of the next microcode address multiplexer to an incrementer and back to the PC register input. Direct jumps are supported by routing a portion of the microinstruction to one of the next microcode address source multiplexer inputs. Conditional jumps are determined in the ALU of the Execution Unit which communicates the decision to the CU via the T1 signal. The T1 signal enables a portion of the microcode word to create the new address. Subroutine jumps are accomplished by loading the contents of the incremented PC register into the PC Save register and then performing a direct jump. Upon completion of the subroutine, the contents of the PC Save register are used as the next microcode address.

A new microinstruction sequence begins when an opcode residing in the IA or IB register is selected by the next microcode address source multiplexer and used as an address to simultaneously access both the CU's Instruction Mapping ROM and the Microcode Storage ROM. The instruction Mapping ROM access provides a pointer which is then used to update the microprogram counter (PC); the Microcode Storage ROM access provides the first microinstruction of the sequence. Remaining microinstructions in a sequence are accessed through the use of the four address generation modes discussed above.

Iterative microprogram operations are achieved through the use of the loop counter. The loop counter may be selectively loaded from either the AD bus or directly from microcode. This counter tracks the number of iterations remaining and, when appropriate, issues a completion signal (CZ). When an iterative operation is called for, the loop counter is loaded and the CU control logic repeats a particular microinstruction sequence, using the four address generation modes discussed above, until the CZ signal is received.

2.2 Instruction Mapping ROM

The CU instruction mapping ROM provides 512 8-bit words of microcode instruction vector storage. The address space of this ROM is mapped into a portion of the microcode storage ROM's address space. Hence, both ROMs are accessed whenever the microcode address falls within this range. The eight bits from the instruction mapping ROM serve as the lower eight bits of a 12-bit microcode address; the upper four bits are a hardwired constant. The 12-bit microcode address formed from the 4-bit constant and the mapping ROM's eight bits are loaded into the PC register of the microsequencer and serve as a means to access non-sequential microcode addresses within the address space allocated to both the instruction mapping and microcode storage ROMs.

Radiation Hard MIL-STD-1750A Control Unit

3.0 Interface Signals

2.3 Microcode ROM

The CU microcode ROM provides 2K (2048) 40-bit words of storage capacity. All of the microcode required to implement the full MIL-STD-1750A Instruction Set Architecture (ISA) fits in one such ROM.

2.4 Buses

A 16-bit multiplexed Address/Data (AD) bus provides a communications path between the CU, the other components of the MAS281 chip set, the MA17504 MMU/BPU, and any other devices mapped into the chip set's address space. The CU receives MIL-STD-1750A instructions, accessed from system memory, over this bus and loads them into its instruction pipeline registers.

A 20-bit multiplexed Microcode (M) bus provides a pathway between the CU chip and the microcode decode logic on all other chips which are under CU microcode control. The 40-bit wide microinstructions from the CU's microcode ROM are multiplexed on chip as two 20-bit words and presented on the interchip M bus during alternate phases of CLK02N. Microcode bits 39 through 20 are placed on the M bus during the CLK02N low phase and bits 19 through 0 during the high phase of CLK02N. The M bus is bidirectional to permit microcode memory expansion.

A 12-bit microcode address (CC) bus is used to route microcode addresses from the next microcode address source multiplexer to the microcode and instruction mapping ROMs as shown in Figure 2.

All signal definitions are shown in Table 1. In addition, each of these functions is provided with Electrostatic Discharge (ESD) protection diodes. All unused inputs must be held to their inactive state via a connection to VDD or GND.

Throughout this data sheet, active low signals are denoted by either a bar over the signal name or by following the name with an "N" suffix. e.g. HOLDN. Referenced signals that are not found on the MA17502 are preceded by the originating chip's functional acronym in parentheses, e.g. (IU)DMAKN.

A description of each pin function, grouped according to functional interface, follows. The function acronym is presented first, followed by its definition, its type, and its detailed description. Function type is either input, output, high impedance (Hi-Z), or a combination thereof. Timing characteristics of each of the functions described are provided in Section 6.0.

3.1 Power Interface

The power interface consists of a single 5V VDD connection and two common GND connections.

3.2 Clocks

The clock interface, discussed below, is the means by which the synchronous, microcoded operation of the MAS281 is driven.

3.2.1 Precharge Clock ($\overline{\text{CLKPC}}$)

Input. The MA17501 Execution Unit (EU), generates the CLKPCN signal for the Control Unit. The Control Unit uses this signal for most of its internal sequencing. During the low phase of CLKPCN, the internal M Bus is precharged to the high state to accelerate its response.

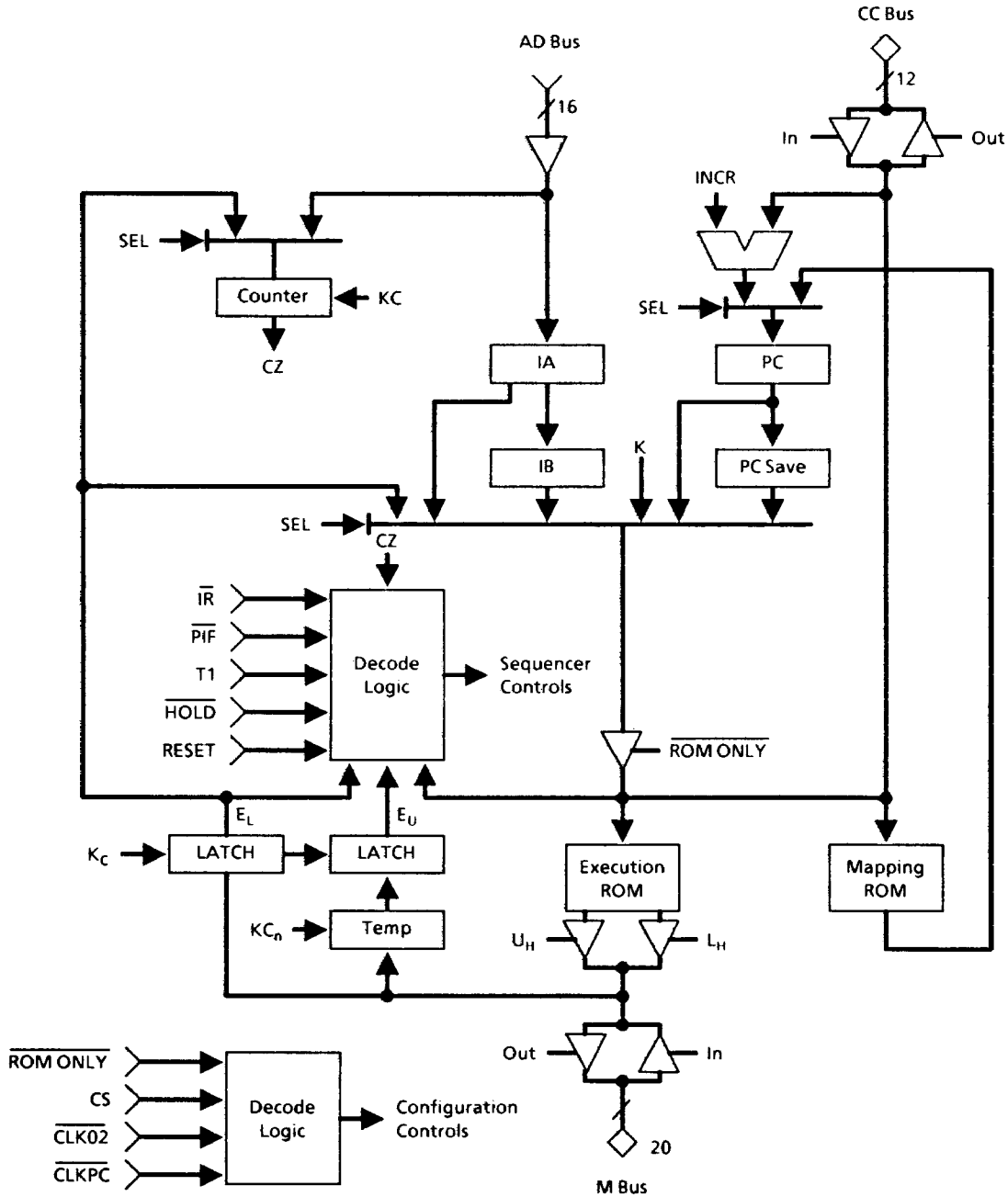

Figure 2. MA17502 Control Unit Architecture

Radiation Hard MIL-STD-1750A Control Unit

The normal CLKPCN period is defined by five OSC cycles (two cycles low and three cycles high). When a microcode branch is indicated by the EU, the low state of CLKPCN is extended to three OSC cycles. During execution of Interrupt Unit decoded XIO and microcode commands, the high state of CLKPCN is extended to four OSC cycles. Also, during external bus cycles, RDYN may be used to cause the EU to prolong the high state of CLKPCN to greater than three OSC cycles; this allows the MAS281 chip set to interface with slower external memory or input/output devices.

During DMA ((IU)DMAKN is low) or Hold ((EU)HLDAKN is low), CLKPCN will remain low until the CPU takes control again.

3.2.2 Phase 2 Clock (CLK02)

Input. The MA17501 generates the CLK02N signal for the Control Unit. The CU then uses this signal, in conjunction with CLKPCN, to control the distribution of microcode on the M Bus. CLK02N is used to multiplex the 40-bit microcode instruction into two 20-bit words (μ W1 and μ W2). The high-to-low edge of CLK02N switches μ W1 (bits 39 through 20) off the M Bus while switching μ W2 (bits 19 through 0) onto the M Bus.

The normal CLK02N period is defined by five OSC cycles (one cycle low, three cycles high, one cycle low). When a microcode branch is indicated by the EU, the high state of CLK02N is extended to four cycles. During execution of Interrupt Unit decoded XIO and microcode commands, the trailing low state of CLK02N is extended to two OSC cycles. Also, during external bus cycles, RDYN may be used to cause the EU to prolong the CLK02N trailing low state to greater than one OSC cycle; this allows the MAS281 chip set to interface with slower external memory or input/output devices.

During DMA ((IU)DMAKN is low) or Hold ((EU)HLDAKN is low), CLKPCN will remain low until the CPU takes control again.

3.3 Buses

The following is a discussion of the communication buses connecting the three-chip set. The AD Bus and M Bus are mainly operand transfer buses, while the CC Bus is strictly for providing microcode addresses to auxiliary CUs.

3.3.1 Address/Data Bus (AD Bus)

Input. These signals comprise the multiplexed address and data bus. During external bus operations, the AD bus accommodates the transfer of instructions, from memory and I/O ports, to the MA17502. During internal bus operations, the AD bus provides additional data to the Control Unit from the Execution Unit. AD00 is the most significant bit position and AD15 is the least significant bit position of both the 16-bit data and 16-bit address. A high on this bus corresponds to a logic 1 and a low corresponds to a logic 0. Information on the AD Bus is clocked into the CU by the high-to-low transition of CLKPCN.

3.3.2 Microcode Bus (M Bus)

Input/Output/Hi-Z. The M Bus is the 20-bit multiplexed microcode bus. The 40-bit microcode instruction is multiplexed onto the M Bus as two 20-bit words (μ W1 and μ W2). The first half of the microcode word, μ W1 (bits 39 through 20), is assured valid on the high-to-low transition of CLK02N and μ W2 (bits 19 through 0) is assured valid on the high-to-low transition of CLKPCN. M00 corresponds to microcode bit 0 (μ W1) or 20 (μ W2) while M19 corresponds to microcode bit 19 (μ W1) or 39 (μ W2). A high level indicates a logic 1 and a low level indicates a logic 0. A high level on CS allows the Control Unit to distribute microcode over this bus, a low level places the bus in the high impedance state.

During DMA or Hold states, CLKPCN is held low, thus holding the internal M bus in the precharged state. Precharging the internal M Bus forces the 20 bits of the external M Bus low.

3.3.3 Microcode Address Bus (CC Bus)

Input/Output/Hi-Z. The CC bus is provided for future expansion and is left unconnected.

**Radiation Hard
MIL-STD-1750A
Control Unit****3.4 Sequencer Control**

The following is a discussion of the microsequencer control input signals. These signals support chip set functions that require microcode branching based on the results of operations performed in the Execution or Interrupt Units.

3.4.1 Interrupt Request ($\overline{\text{IR}}$)

Input. A low on this input directs the CU to service pending interrupt requests latched by the Interrupt Unit (IU). Upon completion of the currently executing MIL-STD-1750A instruction, the CU checks the IRN input. If IRN is low, then the CU sequencer will branch to the microcoded interrupt service routine; else the next MIL-STD-1750A instruction is mapped to its microcode routine. The microcoded interrupt service routine stores the processor state, retrieves the highest priority pending interrupt's service routine processor state, and vectors software execution to the user's interrupt service routine. IRN originates in the IU.

3.4.2 Privileged Instruction Fault ($\overline{\text{PIF}}$)

A low on this signal causes the CU to enable control of the DMA interface (located in the Interrupt Unit), abort the currently executing MIL-STD-1750A instruction and check the IRN input for a pending level 1 interrupt caused by the IU latching a memory protect (MPROEN), memory address (EXADEN), or Bus Time-out fault. PIFN originates in the IU.

3.4.3 Branch or Jump Control (T1)

Input. A high on this input directs the CU microcode address sequencer to branch execution to a non-sequential microcode address. This signal is under the control of the Execution Unit's ALU and its level is dependent on the outcome of the presently executing microcode instruction, e.g. conditional branch. T1 originates in the EU.

3.5 Configuration Control

The following inputs are provided for control of multiple CU systems. They allow for expansion of the microcode store to 4K 40-bit words.

3.5.1 ROM-Only ($\overline{\text{ROMONLY}}$)

Input. This signal is provided for future microcode expansion and must be pulled up to VDD.

3.5.2 Chip Select (CS)

Input. A high on this signal enables the CU to drive the 20-bit external M Bus. This signal is provided for future microcode expansion and must be pulled up to VDD.

3.6 CPU Control

Grouped under this heading are signals that have CPU-wide control of normal operation. Each of these has the ability to "freeze" the processor.

3.6.1 Hold Request ($\overline{\text{HOLD}}$)

Input. A low on this input will suspend internal processor functions at the end of the currently executing MIL-STD-1750A instruction. When this signal becomes active, the CU completes the currently executing MIL-STD-1750A instruction, then branches to the Hold microcode routine and enters the Hold state. The CU will resume normal operation by refilling the instruction pipeline registers (IA and IB) upon release of HOLDN.

3.6.2 System Reset (RESET)

Input. A high on this input for a duration of at least one CLKPCN period will reset the MAS281 chip set by forcing the Control Unit to microcode address zero. The high-to-low transition of this input will cause the CU to begin executing the MAS281 initialisation sequence starting with the first instruction in microcode. Built-in Test (BIT) is performed as part of the initialisation sequence. At the conclusion of initialisation and successful execution of BIT, the MAS281 will be initialised as shown in Table 3.

Radiation Hard MIL-STD-1750A Control Unit

4.0 Operating Modes

The following discussions detail the MAS281 chip set operating modes from the perspective of the Control Unit. MAS281 operating modes involving the MA17502 include: (1) Initialisation, (2) Instruction Execution, (3) Interrupt Servicing, (4) DMA Support, and (5) HOLD Support.

4.1 Initialisation

The MA17502 sequences the MAS281 chip set through the microcoded initialisation routine in response to a high pulse on the RESET input. This routine clears the chip set registers, disables and masks interrupts, reads the configuration register, resets the output discrete register (if applicable), initialises the MMU and BPU (if applicable), performs Built-in Test (BIT), raises the Start-Up ROM Enable discrete, clears and starts timers A and B, resets the Trigger-Go counter, and loads the instruction pipeline. The initialisation sequence is contained in the first 33 locations of microcode ROM (an additional 14 locations contain the optional MMU and BPU initialisation code). Because the initialisation sequence clears the Execution Unit's Instruction Counter and Status Word (also the address and processor state copies stored in the MMU(BPU), if applicable), program execution begins with the instruction located at address zero (page zero). Table 2 provides a detailed breakdown of the initialisation sequence and Table 3 summarises the resulting initialised state.

BIT occupies 332 words of microcode storage ROM, and consists of five subroutines that exercise the internal circuitry of the MAS281, as outlined in Table 4. BIT begins by pulling the Normal Power-UP ((IU)NPU) output low; this is the first time after power-up that the state of NPU is guaranteed. If all five BIT subroutines execute successfully, NPU is raised high.

If any part of BIT fails, an error code identifying the failed subroutine is loaded into the Interrupt Unit Fault Register (via the AD Bus), BIT is aborted, and NPU is left in the low state. Table 4 defines the coding of the BIT results. (NPU is raised high through microcode control of the IU in conjunction with the (EU)INTREN signal. The BIT error codes are loaded in the IU Fault Register via the AD Bus under microcode control of the IU in conjunction with the (EU)INTREN signal.)

In the event of such a failure, the resulting chip set reset state is dependent on where in BIT the error occurred and may not be the same as that shown in Table 3. A BIT failure indication in the fault register sets the level 1 pending interrupt. Since initialisation disables and masks interrupts, the IRN input will remain high; thus the interrupt will not be serviced immediately.

The last action performed by the initialisation routine is to load the instruction pipeline. Instruction fetches start at memory location zero (page zero) from the Start-Up ROM (if implemented). Whether BIT passes or not, the processor will begin instruction execution at this point.

Note: To complete initialisation and pass BIT, interrupt and fault inputs must be high for the duration of the initialisation routine. Also, the Timers A and B must be clocked for BIT success.

**Radiation Hard
MIL-STD-1750A
Control Unit**

Label	Cycle	
MAIN	B1	1. Enable Control of DMAE Output signal
	P	2. -
	B1	3. Clear MAS281 Execution Unit Status Word (SW) Clear Interrupt Mask (MK) (Internal I/O command, SKM, 2000H)
	B1	4. Clear Pending Interrupt Register (PI) and Fault Register (FT) (Internal I/O Command, CLIR, 2001H) Clear Instruction Counter (IC)
	P	5. -
	B1	6. Disable Interrupts (Internal I/O Command, DSBL, 2003H)
	P	7. -
	B1	8. Clear MMU Status Word (Internal I/O Command, WSW, 200EH) (Note 1)
	P	9. -
	B1	10. Disable DMA Access (Internal I/O Command, DMAD, 4007H)
	P	11. -
	B1	12. Read Configuration Register (Internal I/O Command, RCW, 8400H, CONFVN Drops low per Figure 25, Section 5 0)
	P	13. -
	P	14. -
	B2	15. -(If Output Discrete Register Present, then Continue; Else, Skip to 18.)
	P	(16) -
	I/O	(17) Clear Output Discrete Register (External I/O Command)
	P	18. -
	B2	19. -(If BPU present, then Branch to BPU; else, continue)
	P	20. -
	B2	21. -(If MMU present, then Branch to MMU; Else, Continue)
	P	22. -(Setup Temporary Register to indicate No MMU Present)
	B2	23. -(Branch to MAS281 BIT)
	P	24. -
	B1	25. Enable Start-Up ROM (Internal I/O Command, ESUR, 4004H; SURE Raises High per Figure 25, Section 5 0)
	P	26. -
	B1	27. Clear and Start Timer A (Internal I/O Command, OTA, 400AH)
	B1	28. Reset the Trigger-Go timer (Internal I/O Command, GO, 400BH)
	P	29. -
	B1	30. Clear and Start Timer B (Internal I/O Command, OTB, 400EH)
	B2	31. -(Branch to Load Instruction Pipeline Routine)
	M	32. Load data-In register (DI) and instruction Register A (IA) from [IC], Increment IC
	M	33. Load Data-In Register (DI) and Instruction Register a (IA) from [IC] ([IA] Moves to IB), Increment IC, Map Instruction Register B (IB) into Microcode Routine
BPU	P	(1) -
	P	(2) -(Set Loop to Clear Memory Protect RAM)
	I/O	(3) Clear a Location in MPRAM (Internal I/O Command, LMP, 50XXH), Increment Address; Do 128 Times
		(4) -(Branch Back to 20)
MMU	P	(1) -
	P	(2) -
	P	(3) -(Setup Loop to Load Instruction Page Registers (IPR) and Operand Page Registers (OPR) with Sequential Values of 0 to 255)
	P	(4) -
	P	(5) -
	I/O	(6) Load a Location in the IPR with the value of the Location Address (Internal I/O Command, WIPR, 51XYH)
	I/O	(7) Load a Location in the OPR Increment Loaded Value with the Value of the Location Address (Internal I/O Command, WOPR, 52XYH)
	P	(8) -(Increment IPR Address)
	P	(9) -(Increment OPR Address; Repeat Loop [4 - 9] 256 Times)
	B2	(10) -(Setup Temporary Register to Indicate MMU Present; Branch back to 23)

Notes:

- This operation is performed whether or not an MMU is present.
- "-" indicates internal CPU operation.
- Sequence numbers in "()" are performed only under the stated conditions.
- Each step enumerated above represents a single machine (SYNC) cycle of the type shown in the "Cycle" column.
 "P" indicates a 5 OSC cycle, 60% duty cycle, machine cycle.
 "I/O" and "M" indicate a 5 OSC cycle, 50% duty cycle, machine cycle.
 "B1" indicates a 6 OSC cycle, 50% duty cycle, machine cycle.
 "B2" indicates a 6 OSC cycle, 66% duty cycle, machine cycle.

Table 2. MAS281 Initialisation Sequence

Radiation Hard MIL-STD-1750A Control Unit

MAS281	
Instruction Counter (IC)	Zeroed
Status Word (EU and MMU) (SW)	Zeroed
Fault (FT)	Zeroed
Pending Interrupt (PI)	Zeroed
Mask (MK)	Zeroed
General Register File (R0 R15)	Zeroed
Interrupts	Disabled
DMA Access	Disabled
Timer A	Reset and Started
Timer B	Reset and Started
Trigger-Go Timer	Reset and Started
MMU	
Page Registers	Group Zero Enabled
AL, W, E, Fields	Zeroed
PPA Field	Logical to Physical Map
BPU	
Write Protect	Zeroed
Global Memory Protect	Enabled

Table 3. Initialisation State

BIT	Test Coverage	BIT Fail Codes (FT _{13, 14, 15})	Cycles
1	Microcode Sequencer IB Register Control Barrel Shifter Byte Operations and Flags	100	221
2	Temporary Registers (T0 - T7) Microcode Flags Multiply Divide	101	166
3	Interrupt Unit - MK, PI, FT Enable/Disable Interrupts	111	214
4	Status Word Control User Flags General Registers (R0 - R15)	110	154
5	Timer A Timer B	111	763
-	BIT Pass/Fail Overhead	-	26

Note: BIT pass is indicated by all zeros in FT bits 13, 14 and 15.

Table 4. Built In Test (BIT) Summary

**Radiation Hard
MIL-STD-1750A
Control Unit****4.2 Instruction Execution**

The MIL-STD-1750A microcoded instruction subroutines are stored in 1255 locations of microcode storage ROM. The Control Unit receives instructions from memory, via the AD Bus, through the instruction pipeline registers IA and IB. When the previous instruction or special process (Interrupts or Hold) has been completed, the new instruction residing in register IB is selected by the next microcode address source multiplexer. A 4-bit hardwired constant, appended by the instruction opcode, is then used as the first address of a microcode sequence which distributes the required control to execute the instruction. The microsequencer generates the remaining microcode addresses necessary to complete the sequence as described in Section 2.0 of this data sheet entitled, "Architecture".

Upon completion of the current instruction, the CU will accept the next instruction in the program unless an interrupt, DMA, or Hold request is received. The interrupt and Hold request share a common branch point in microcode. If an interrupt and Hold request are both pending at the conclusion of the MIL-STD-1750A instruction microcode routine, the Hold request has priority and is serviced first. Upon release of the Hold state, the first instruction will execute even if the interrupt is still pending; when this instruction is complete the interrupt will be serviced (assuming the HOLDN input has not been driven low during execution of this instruction). Interrupt, DMA, and Hold support are explained in more detail in following sections.

4.3 Direct Memory Access

Direct Memory Access (DMA) is controlled by the Execution Unit (EU) in concert with the Interrupt Unit DMA interface. The CU supports DMA by suspending processor control upon completion of the current machine cycle. If DMA is enabled ((UI)DMAE signal, high) a DMA request ((IU)DMARN input, low) to the MAS281 causes the IU to acknowledge with DMAKN, low. When the EU receives the DMAKN (DMA Acknowledge) signal from the IU, the CU clocks are suspended (CLKPCN, low; CLK02N, high) halting the MAS281's microcode sequencing. Microinstruction execution remains suspended until DMARN is removed. When DMARN is removed, microcode execution resumes where DMARN had interrupted it.

4.4 Interrupt Handling

Interrupts are handled by the interrupt Unit (IU) and communicated to the CU via the IRN input. The CU checks the status of the IRN (Interrupt Request) signal after the completion of each MIL-STD-1750A microcode instruction sequence. If the IRN signal is low, the CU initiates interrupt handling, otherwise the CU processes a new instruction.

IU interrupt handling is controlled by the CU through three microcode bits - M04, M05, and M06. Upon receipt of the IRN signal and after completion of the currently executing instruction, the CU branches to a microcoded interrupt handling routine. The microprogram sequence supplies microcoded control to the IU for reading the highest priority pending interrupt vector code, which also clears this pending interrupt.

Due to the similarity of interrupt and hold request handling by the CU, if a Hold and interrupt request are pending at the end of an instruction sequence the Hold has priority and will be serviced.

4.5 Hold Support

The CU accepts a Hold request in much the same way as an interrupt request. After the completion of each MIL-STD-1750A microcode instruction sequence, the CU checks the status of the HOLDN signal. If the HOLDN signal is low, a microcoded sequence suspends further internal processing functions; otherwise, the CU processes a new instruction or services interrupt requests (Hold requests have priority over interrupt requests).

The Control Unit responds to an active HOLDN signal, upon completion of the currently executing instruction, but branching to a microprogrammed sequence of instructions that suspends all internal operations. This sequence of microinstructions allows the processor to resume instruction execution at the point HOLDN was accepted when the CU regains control of the processor. The MAS281 remains in the Hold state until HOLDN is pulled high (if the Hold state was reached through the hardware interface, HOLDN) or HOLDN is pulsed low (if the Hold state was reached through software, BPT instruction).

This page intentionally blank

**Radiation Hard
MIL-STD-1750A
Control Unit**

5.0 Software Considerations

The MAS281 chip set implements the full MIL-STD-1750A instruction set. Table 6a gives a brief listing of this instruction set and provides performance data for each instruction. Table 6b provides a summary of the I/O commands implemented in MAS281 and MA17504 MMU/BPU hardware. A complete description of this instruction set is provided in MIL-STD-1705A (Notice 1). The register set available to the software programmer is depicted in Figure 3. A discussion of data types, addressing modes, and benchmarking considerations follows.

5.1 Data Types

The MAS281 chip set supports 16-bit fixed-point single-precision, 32-bit fixed-point double-precision, 32-bit floating-point, and 48-bit extended-precision floating-point data types. Figure 4 depicts the formats of these data types.

All numerical data is represented in two's complement form. Floating-point numbers are represented by a fractional two's complement mantissa with an 8-bit two's complement exponent. The MAS281 expects all floating point operands to be normalised. If they are not normalised, the results from an instruction are not defined.

5.2 Addressing Modes

The MAS281 chip set supports the eight addressing modes specified in MIL-STD-1750A. These addressing modes are shown in Figure 5 and are defined below.

5.2.1 Register Direct (R)

The register specified by the instruction (RB) contains the required operand.

5.2.2 Memory Direct (D,DX)

Memory Direct (without indexing) is an addressing mode in which the instruction contains the memory address (A) of the required operand. In Memory Direct (indexed), the memory address of the required operand is specified by the sum of the contents of an index register (RX) and the instruction address field (A). Registers R1 through R15 may be specified for indexing.

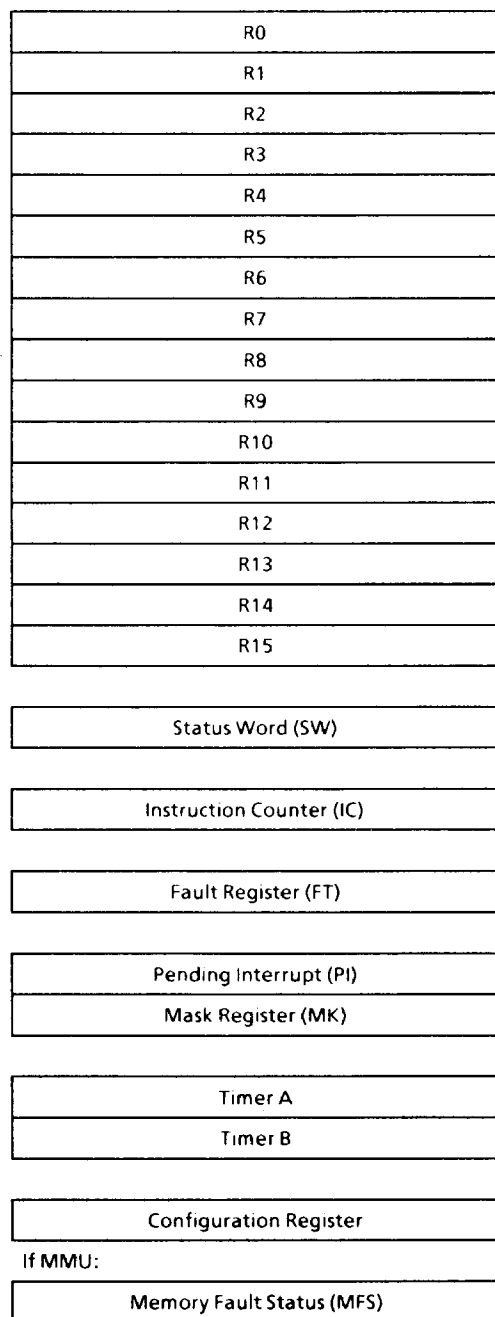

Figure 3. Register Set Model

5.2.3 Memory Indirect (I,IX)

Memory Indirect (without indexing) is an addressing mode in which the memory address (A) specified by the instruction contains the address of the required operand. In Memory Indirect (pre-indexed), the sum of the contents of a specified index register (RX) and the instruction address field (A) is the address of the address of the required operand. Registers R1 through R15 may be specified for indexing.

5.2.4 Immediate Long (IM)

There are two formats that implement Immediate Long Addressing; one allows indexing and one does not. For the indexable format, if the specified index register (RX) is not equal to zero, the contents of RX are added to the immediate field to form the required operand, otherwise, the immediate field contains the required operand.

5.2.5 Immediate Short (IS)

In this mode the required 4-bit operand is contained within the 16-bit instruction. The Immediate Short addressing mode accommodates two formats; one which interprets the contents of the immediate field as positive data and the other which interprets the contents of the immediate field as negative data.

5.2.6 Immediate Short Positive (ISP)

The immediate operand is treated as a positive integer between 1 and 16.

5.2.7 Immediate Short Negative (ISN)

The immediate operand is treated as a negative integer between 1 and 16. Its internal form is a two's complement, sign-extended 16-bit number.

5.2.8 Instruction Counter Relative (ICR)

This addressing mode is used for 16-bit branch instructions. The contents of the instruction counter minus two (the address of the current instruction) is added to the sign-extended 8-bit displacement field (D) within the instruction. This sum then points to the memory address to which control may be transferred if a branch is to be taken.

Byte

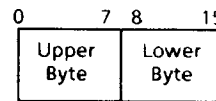

Single-Precision Fixed-Point

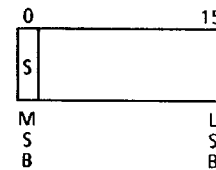

Double-Precision Fixed-Point

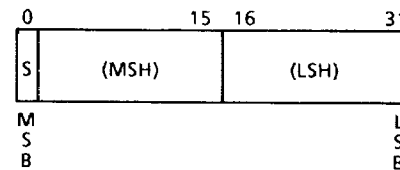

Floating-Point

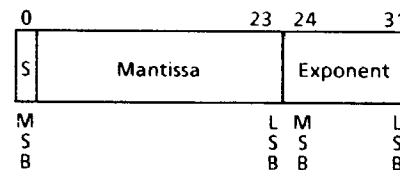

Extended-Precision Floating-Point

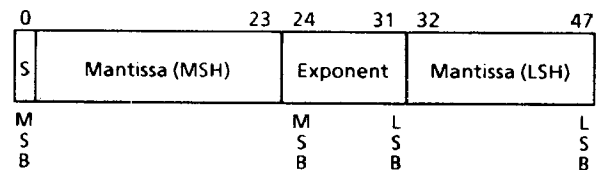

Figure 4. Data Formats

Mode	Format												
1. Register Direct "R"	<table border="1"> <tr> <td>0</td> <td>7 8</td> <td>11 12</td> <td>15</td> </tr> <tr> <td>OC</td> <td>RA</td> <td>RB</td> <td></td> </tr> </table>	0	7 8	11 12	15	OC	RA	RB					
0	7 8	11 12	15										
OC	RA	RB											
2. Memory Direct "D" "DX"	<table border="1"> <tr> <td>0</td> <td>7 8</td> <td>11 12</td> <td>15</td> <td>16</td> <td>31</td> </tr> <tr> <td>OC</td> <td>RA</td> <td>RX</td> <td colspan="3">A</td> </tr> </table> <p>RX = 0 (Non-Indexed) RX ≠ 0 (Indexed)</p>	0	7 8	11 12	15	16	31	OC	RA	RX	A		
0	7 8	11 12	15	16	31								
OC	RA	RX	A										
3. Memory Indirect "I" "IX"	<table border="1"> <tr> <td>0</td> <td>7 8</td> <td>11 12</td> <td>15</td> <td>16</td> <td>31</td> </tr> <tr> <td>OC</td> <td>RA</td> <td>RX</td> <td colspan="3">A</td> </tr> </table> <p>RX = 0 (Non-Indexed) RX ≠ 0 (Indexed)</p>	0	7 8	11 12	15	16	31	OC	RA	RX	A		
0	7 8	11 12	15	16	31								
OC	RA	RX	A										
4. Immediate Long a. Not Indexable "IM"	<table border="1"> <tr> <td>0</td> <td>7 8</td> <td>11 12</td> <td>15</td> <td>16</td> <td>31</td> </tr> <tr> <td>OC</td> <td>RA</td> <td>OCX</td> <td colspan="3">I</td> </tr> </table>	0	7 8	11 12	15	16	31	OC	RA	OCX	I		
0	7 8	11 12	15	16	31								
OC	RA	OCX	I										
b. Indexable "IM" "IMX"	<table border="1"> <tr> <td>0</td> <td>7 8</td> <td>11 12</td> <td>15</td> <td>16</td> <td>31</td> </tr> <tr> <td>OC</td> <td>RA</td> <td>RX</td> <td colspan="3">I</td> </tr> </table> <p>RX = 0 (Non-Indexed) RX ≠ 0 (Indexed)</p>	0	7 8	11 12	15	16	31	OC	RA	RX	I		
0	7 8	11 12	15	16	31								
OC	RA	RX	I										
5. Immediate Short a. Positive "ISP"	<table border="1"> <tr> <td>0</td> <td>7 8</td> <td>11 12</td> <td>15</td> </tr> <tr> <td>OC</td> <td>RA</td> <td>I</td> <td></td> </tr> </table>	0	7 8	11 12	15	OC	RA	I					
0	7 8	11 12	15										
OC	RA	I											
b. Negative "ISN"	<table border="1"> <tr> <td>0</td> <td>7 8</td> <td>11 12</td> <td>15</td> </tr> <tr> <td>OC</td> <td>RA</td> <td>I</td> <td></td> </tr> </table>	0	7 8	11 12	15	OC	RA	I					
0	7 8	11 12	15										
OC	RA	I											
6. IC Relative "ICR"	<table border="1"> <tr> <td>0</td> <td>7 8</td> <td>15</td> </tr> <tr> <td>OC</td> <td>D</td> <td></td> </tr> </table>	0	7 8	15	OC	D							
0	7 8	15											
OC	D												
7. Base Relative a. Not Indexable "B"	<table border="1"> <tr> <td>0</td> <td>5 6 7 8</td> <td>15</td> </tr> <tr> <td>OC</td> <td>BR'</td> <td>DU</td> </tr> </table> <p>BR' = BR-12</p>	0	5 6 7 8	15	OC	BR'	DU						
0	5 6 7 8	15											
OC	BR'	DU											
b. Indexable "B" "BX"	<table border="1"> <tr> <td>0</td> <td>5 6 7 8</td> <td>11 12</td> <td>15</td> </tr> <tr> <td>OC</td> <td>BR'</td> <td>OCX</td> <td>RX</td> </tr> </table> <p>RX = 0 (Non-Indexed) RX ≠ 0 (Indexed)</p>	0	5 6 7 8	11 12	15	OC	BR'	OCX	RX				
0	5 6 7 8	11 12	15										
OC	BR'	OCX	RX										
8. Special "S"	<table border="1"> <tr> <td>0</td> <td>7 8</td> <td>11 12</td> <td>15</td> </tr> <tr> <td>OC</td> <td>S1</td> <td>S2</td> <td></td> </tr> </table>	0	7 8	11 12	15	OC	S1	S2					
0	7 8	11 12	15										
OC	S1	S2											

Legend:

- OC = Operation Code
- RA = Destination Register
- RB = Source Register
- RX = Index Register
- A = Address (Logical)
- OCX = Extension to Operation Code
- I = Immediate Data
- D = Displacement
- BR' = Base Register Reference
- DU = Displacement (Positive)
- S1, S2 = Special Code

Figure 5. Addressing Modes

Radiation Hard MIL-STD-1750A Control Unit

5.2.9 Base Relative (B)

There are two formats which implement Base Relative Addressing; one allows indexing and one does not. For the non-indexable form the contents of the instruction specified base register ($BR = BR' + 12$) is added to the 8-bit displacement field (DU) of the 16-bit instruction. For the indexable form, the sum of the contents of a specified index register (RX) and a specified base register ($BR = BR' + 12$) is the address of the required operand. Registers R1 through R15 may be specified for indexing and the base register may be R12 through R15.

5.2.10 Special (S)

This addressing mode is applicable to instructions that do not follow the above formats.

5.3 Benchmarking

Table 6a defines the number and type of machine cycles associated with each MIL-STD-1750A instruction. This information may be used when benchmarking MAS281 performance. The Digital Avionics Instruction Set (DAIS) mix, which defines a typical frequency of occurrence for MIL-STD-1750A instructions, is used here for this purpose.

One problem with the DAIS mix, however, is that it does not reflect the impact of data dependencies on system performance. For example, a multiplication in which one operand is zero may be performed much faster than one with two non-zero operands. Also, the DAIS mix does not specify such time consuming operations as normalization and alignment.

Realistic benchmarks must therefore take both an instruction mix and data dependencies into account. To this end, machine cycle counts in Table 6a which have data dependencies are annotated with either an "a" suffix to reflect an average number of machine cycles (where each of several possibilities is equally likely) or with a "wa" suffix to reflect a weighted average number of machine cycles (where some data possibilities are more likely than others). Weighted averages are only applicable to floating-point operations.

Weighted averages provided in Table 6a, based on the Sweeney (IBM Systems Journal, Vol. 4, No. 1, 1965) guidelines, take a wide range of data dependencies into consideration. Normalization and alignment operations are also represented. Table 5 defines MAS281 throughput, at various frequencies and wait states, for the DAIS mix using Sweeney data dependencies.

It should be noted that using the Sweeney guidelines is a conservative approach to benchmarking. If best case assumptions are made and such operations as normalization and alignment are not considered, MAS281 performance figures are approximately 50% higher than those indicated in Table 5.

25	743.4	698.3	658.4	622.8
20	594.7	558.7	526.7	498.2
15	446.0	419.0	395.0	373.7
10	297.4	279.3	263.4	249.1
	0	1	2	3
	Number of Wait States in Memory Access Cycle			

Table 5. Throughput (KIPS)

**Radiation Hard
MIL-STD-1750A
Control Unit**

5.4 Instruction Summary

Operation	Op Code/Ext	Mnemonic	Format	Cycles *		
				M	P	B
LOAD/STORE						
Single Precision Load	81	LR	R	1	0	0
	0X	LB	B	2	1	0
	4X 0	LBX	BX	2	1	0
	82	LISP	ISP	1	0	0
	83	LISN	ISN	1	0	0
	80	L	D,DX	3	0	0
	85	LIM	IM,IMX	2	0	0
	84	LI	I,IX	4	1	0
Double-Precision Load	87	DLR	R	1	2	0
	0X	DLB	B	3	1	0
	4X 1	DLBX	BX	3	2	0
	86	DL	D,DX	4	0	0
	88	DLI	I,IX	5	1	0
Single-Precision Store	0X	STB	B	2	2	0
	4X 2	STBX	BX	2	2	0
	90	ST	D,DX	3	1	0
	94	STI	I,IX	4	1	0
Store a Non-Negative Constant	91	STC	D,DX	3	1	0
	92	STCI	I,IX	4	1	0
Double-Precision Store	0X	DSTB	B	3	2	0
	4X 3	DSTX	BX	3	2	0
	96	DST	D,DX	4	0	0
	98	DSTI	I,IX	5	1	0
Load Multiple Registers	89	LM	D,DX	3 + n	1	1
Store Multiple Registers	99	STM	D,DX	3 + n	1	1
INTEGER ARITHMETIC						
Single-Precision Integer Add	A1	AR	R	1	1	0
	1X	AB	B	2	2	0
	4X 4	ABX	BX	2	2	0
	A2	AISP	ISP	1	1	0
	A0	A	D,DX	3	1	0
	4A 1	AIM	IM	2	1	0
Increment Memory by a Positive Integer	A3	INCM	D,DX	4	1	0
Single-Precision Absolute Value of Register	A4	ABS	R	1	1.5	1a
Double-Precision Absolute Value of Register	A5	DABS	R	1	2.5	1a

*M = memory, P = processor (5 OSC cycles), B = processor (6 OSC cycles).

a = average if more than one alternative exists

Table 6a. Instruction Summary

Radiation Hard MIL-STD-1750A Control Unit

Operation	Op Code/Ext	Mnemonic	Format	Cycles *		
				M	P	B
Double-Precision Integer Add	A7	DAR	R	1	3	0
	A6	DA	D,DX	4	1	0
Single Precision Integer Subtract	B1	SR	R	1	1	0
	1X	SBB	B	2	2	0
	4X 5	SBBX	BX	2	2	0
	B2	SISP	ISP	1	1	0
	B0	S	D,DX	3	1	0
Decrement Memory by a Positive Integer	4A 2	SIM	IM	2	1	0
	B3	DECM	D,DX	4	1	0
Single Precision Negate Register	B4	NEG	R	1	1	0
Double-Precision Negate Register	B5	DNEG	R	1	3	0
Double-Precision Integer Subtract	B7	DSR	R	1	3	0
	B6	DS	D,DX	4	1	0
Single Precision Integer Multiply with 16-Bit Product	C1	MSR	R	1	6.5	4a
	C2	MISP	ISP	1	7.5	4a
	C3	MISN	ISN	1	7.5	4a
	C0	MS	D,DX	3	6.5	4a
	4A 4	MSIM	IM	2	6.5	4a
Single Precision Integer Multiply with 32-Bit Product	C5	MR	R	1	5	3
	1X	MB	B	2	7	3
	4X 6	MBX	BX	2	7	3
	C4	M	D,DX	3	5	3
	4A 3	MIM	IM	2	5	3
Double-Precision Integer Multiply	C7	DMR	R	1	41	4.5a
	C6	DM	D,DX	4	40	4.5a
Single Precision Integer Divide with 16-Bit Dividend	D1	DVR	R	1	20.25	5.5a
	D2	DISP	ISP	1	20	5.5a
	D3	DISN	ISN	1	20.5	5.5a
	D0	DV	D,DX	3	20.25	5.5a
	4A 6	DVIM	IM	2	20.25	5.5a
Single Precision Integer Divide with 32-Bit Dividend	D5	DR	R	1	21.75	6.5a
	1X	DB	R	2	22.75	6.5a
	4X 7	DBX	BX	2	22.75	6.5a
	D4	D	D,DX	3	21.75	6.5a
	4A 5	DIM	IM	2	22.75	6.5a
Double-Precision Integer Divide	D7	DDR	R	1	79.5	5.5a
	D6	DD	D,DX	4	77.5	5.5a

*M = memory, P = processor (5 OSC cycles), B = processor (6 OSC cycles).

a = average if more than one alternative exists

Table 6a (continued). Instruction Summary

**Radiation Hard
MIL-STD-1750A
Control Unit**

Operation	Op Code/Ext	Mnemonic	Format	Cycles *		
				M	P	B
LOGICAL						
Inclusive Logical OR	E1	ORR	R	1	0	0
	3X	ORB	B	2	1	0
	4X F	ORBX	BX	2	1	0
	E0	OR	D,DX	3	0	0
	4A 8	ORIM	IM	2	0	0
Logical AND	E3	ANDR	R	1	0	0
	3X	ANDB	B	2	1	0
	4X E	ANDX	BX	2	1	0
	E2	AND	D,DX	3	0	0
	4A 7	ANDM	IM	2	0	0
Exclusive Logical OR	E5	XORR	R	1	0	0
	E4	XOR	D,DX	3	0	0
	4A 9	XORM	IM	2	0	0
Logical NAND	E7	NR	R	1	1	0
	E6	N	D,DX	3	1	0
	4A B	NIM	IM	2	1	0
Set Bit	51	SBR	R	1	0	0
	50	SB	D,DX	4	1	0
	52	SBI	I,IX	5	2	0
Reset Bit	54	RBR	R	1	1	0
	53	RB	D,DX	4	1	0
	55	RBI	I,IX	5	2	0
Test Bit	57	TBR	R	1	0	0
	56	TB	D,DX	3	0	0
	58	TBI	I,IX	4	1	0
Test and Set Bit	59	TSB	D,DX	4	0	2
Set Variable Bit in Register	5A	SVBR	R	1	0	1
Reset Variable Bit in Register	5C	RVBR	R	1	1	1
Test Variable Bit in Register	5E	TVBR	R	1	0	1
Store Register Through Mask	97	SRM	D,DX	4	3	0
BYTE						
Load From Upper Byte	8B	LUB	D,DX	3	0	0
	8D	LUBI	I,IX	4	1	0
Load From Lower Byte	8C	LLB	D,DX	3	1	0
	8E	LLBI	I,IX	4	2	0
Store Into Upper Byte	9B	STUB	D,DX	4	1	0
	9D	SUBI	I,IX	5	3	0
Store Into Lower Byte	9C	STLB	D,DX	4	1	0
	9E	SLBI	I,IX	5	2	0
Exchange Bytes in Register	EC	XBR	S	1	0	1

*M = memory, P = processor (> 0.5C cycles), B = processor (< 0.5C cycles).

Table 6a (continued). Instruction Summary

Radiation Hard MIL-STD-1750A Control Unit

Operation	Op Code/Ext	Mnemonic	Format	Cycles *		
				M	P	B
COMPARE						
Single-Precision Compare	F1	CR	R	1	0	0
	3X	CB	B	2	1	0
	4X C	CBX	BX	2	1	0
	F2	CISP	ISP	1	0	0
	F3	CISN	ISN	1	0	0
	F0	C	D,DX	3	0	0
	4A A	CIM	IM	2	0	0
Compare between Limits	F4	CBL	D,DX	4	2.75	1.75a
Double-Precision Compare	F7	DCR	R	1	2	0
	F6	DC	D,DX	4	0	0
JUMP/BRANCH						
Jump on Condition	70	JC	D,DX	2	0.5	1a
	71	JCI	I,IX	3	0.5	1a
Jump to Subroutine	72	JS	D,DX	2	2	0
Subtract One and Jump	73	SOJ	D,DX	2	2.5	1a
Branch Unconditionally	74	BR	ICR	2	2	0
Branch if Equal to (Zero)	75	BEZ	ICR	1.5	1	1a
Branch if Less than (Zero)	76	BLT	ICR	1.5	1	1a
Branch to Executive	77	BEX	S	16	12	3a
Branch if Less than or Equal to (Zero)	78	BLE	ICR	1.5	1	1a
Branch if Greater than (Zero)	79	BGT	ICR	1.5	1	1a
Branch if Not Equal to (Zero)	7A	BNZ	ICR	1.5	1	1a
Branch if Greater than or Equal to (Zero)	7B	BGE	ICR	1.5	1	1a
SHIFT						
Shift Left Logical	60	SLL	R	1	1	0
Shift Right Logical	61	SRL	R	1	1	0
Shift Right Arithmetic	62	SRA	R	1	1	0
Shift Left Cyclic	63	SLC	R	1	1	0
Double Shift Left Logical	65	DSLL	R	1	3	0
Double Shift Right Logical	66	DSRL	R	1	2	0
Double Shift Right Arithmetic	67	DSRA	R	1	2	0
Double Shift Left Cyclic	68	DSLCL	R	1	3	0
Shift Logical, Count in Register	6A	SLR	R	1	1	3
Shift Arithmetic, Count in Register	6B	SAR	R	1	1.5	3.50a
Shift Cyclic, Count in Register	6C	SCR	R	1	1	3.25a
Double Shift Logical, Count in Register	6D	DSLRL	R	1	2.25	4a
Double Shift Arithmetic, Count in Register	6E	DSAR	R	1	3.19	4.94a
Double Shift Cyclic, Count in Register	6F	DSCRL	R	1	3.5	3a

*M = memory, P = processor (5 OSC cycles), B = processor (6 OSC cycles),
a = average if more than one alternative exists

Table 6a (Continued). Instruction Summary

**Radiation Hard
MIL-STD-1750A
Control Unit**

Operation	Op Code/Ext	Mnemonic	Format	Cycles *		
				M	P	B
CONVERT						
Convert Floating-Point to 16-Bit Integer	E8	FIX	R	1	4.25	4.5a
Convert 16-Bit Integer to Floating-Point	E9	FLT	R	1	3	2a
Convert Extended-Precision Floating-Point to 32-Bit Integer	EA	EFIX	R	1	12.25	6.25a
Convert 32-Bit Integer to Extended-Precision Floating-Point	EB	EFLT	R	1	7.5	3.5a
STACK						
Stack IC and Jump to Subroutine	7E	SJS	D,DX	4	3	0
Unstack IC and return from Subroutine	7F	URS	S	3	1	1
Pop Multiple registers off the Stack	8F	POPM	S	2.5 + n (n = 0 to 15)	2.25 + n (n = 0 to 15)	4.25a
Push Multiple Registers onto the Stack	9F	PSHM	S	1 + n (n = 0 to 15)	4.5 + n (n = 0 to 15)	2a
I/O (See I/O Command Summary)						
Execute I/O Vectored I/O	48 49	XIO** VIO**	IM,IMX D,DX	3 -	3.583 -	6.277a -
SPECIAL						
Built-In Function Call	4F	BIF	S			
Move Multiple Words, Memory-to-Memory	93	MOV	S	1 + 4n	1 + 3n	1 + 2na
Exchange Words in Registers	ED	XWR	R	1	2	0
Load Status	7D 7C	LST** LSTI**	D,DX I,IX	8 9	2 2	3 4
No Operation	FF	NOP	S	1	2	2
Break Point	FF	BPT	S	3	4	4

*M = memory, P = processor (5 OSC cycles), B = processor (6 OSC cycles),
a = average if more than one alternative exists
** Privileged instruction.

Table 6a (Continued). Instruction Summary

Radiation Hard MIL-STD-1750A Control Unit

Operation	Op Code/Ext	Mnemonic	Format	Cycles *		
				M	P	B
FLOATING-POINT						
Extended-Precision Floating-Point Load	8A	EFL	D,DX	5	0	1
Extended-Precision Floating-Point Store	9A	EFST	D,DX	5	0	1
Floating-Point Absolute Value of Register	AC	FABS	R	1	1.75	3.25a
Floating-Point Negate Register	BC	FNEG	R	1	3.25	3.75a
Floating-Point Compare	F9	FCR	R	1	2.75	2.875wa
	3X	FCB	B	2	2.75	2.875wa
	4X D	FCBX	BX	2	2.75	2.875wa
	F8	FC	D,DX	3	1.75	2.875wa
Extended-Precision Floating-Point Compare	FB	EFCR	R	1	3.25	2.875wa
	FA	EFC	D,DX	4.25a	2.75	2.875wa
Floating-Point Add	A9	FAR	R	1	7.625	8.25wa
	2X	FAB	B	3	6.625	8.25wa
	4X 8	FABX	BX	3	6.625	8.25wa
	A8	FA	D,DX	4	5.625	8.25wa
Extended-Precision Floating-Point Add	AB	EFAR	R	1	21.3125	10.5625wa
	AA	EFA	D,DX	5	19.3125	10.5625wa
Floating-Point Subtract	B9	FSR	R	1	8.625	8.625wa
	2X	FSB	B	3	7.625	8.625wa
	4X 9	FSBX	BX	3	7.625	8.625wa
	B8	FS	D,DX	4	6.625	8.625wa
Extended-Precision Floating-Point Subtract	BB	EFSR	R	1	23.0625	11.8125wa
	BA	EFS	D,DX	5	21.0625	11.8125wa
Floating-Point Multiply	C9	FMR	R	1	12.75a	6.25wa
	2X	FMB	B	3	12.75a	6.25wa
	4X A	FMBX	BX	3	12.75a	6.25wa
	C8	FM	D,DX	4	11.75a	6.25wa
Extended-Precision Floating-point Multiply	CB	EFMR	R	1	59.75	6.25wa
	CA	EFM	D,DX	5	57.75	6.25wa
Floating-Point Divide	D9	FDR	R	1	31.5	32.75wa
	2X	FDB	B	3	30.5	32.75wa
	4X B	FDBX	BX	3	30.5	32.75wa
	D8	FD	D,DX	4	29.5	32.75wa
Extended-Precision Floating-Point Divide	DB	EFDR	R	1	102.625	47.875wa
	DA	EFD	D,DX	5	100.625	47.875wa

*M = memory, P = processor (5 OSC cycles), B = processor (6 OSC cycles).
a = average if more than one alternative exists
wa = weighted average favouring one or more possible alternatives.

Table 6a (Continued). Instruction Summary

**Radiation Hard
MIL-STD-1750A
Control Unit**

4.5 Internal I/O Command Summary

Operation	Command Code (Hex)	Mnemonic	Cycles *		
			M	P	B
Implemented in MAS281					
Set Fault Register	0401	SFR	2	3	9
Set Interrupt Mask	2000	SMK	2	3	9
Clear Interrupt request	2001	CLIR	2	3	9
Enable Interrupts	2002	ENBL	2	3	9
Disable Interrupts	2003	DSBL	2	3	9
Reset Pending Interrupt	2004	RPI	2	3	9
Set Pending Interrupt Register	2005	SPI	2	3	9
Reset Normal Power Up Discrete	200A	RNS	2	3	9
Write Status Word	200E	WSW	2	3a	8.5a
Enable Start-Up ROM	4004	ESUR	2	3	9
Disable Start-Up ROM	4005	DSUR	2	3	9
Direct Memory Access Enable	4006	DMAE	2	3	9
Direct Memory Access Disable	4007	DMAD	2	3	9
Timer A Start	4008	TAS	2	3	9
Timer A Halt	4009	TAH	2	3	9
Output Timer A	400A	OTA	2	3	9
Reset Trigger-Go	400B	GO	2	3	9
Timer B Start	400C	TBS	2	3	9
Timer B Halt	400D	TBH	2	3	9
Output Timer B	400E	OTB	2	3	9
Read Configuration Word	8400	RCW	2	2	4
Read Fault Register Without Clear	8401	RFR	2	2	4
Read Interrupt Mask	A000	RMK	2	2	4
Read Pending Interrupt Register	A004	RPIR	2	2	4
Read Status Word	A00E	RSW	2	1	4
Read and Clear Fault Register	A00F	RCFR	2	2	4
Input Timer A	C00A	ITA	2	2	4
input Timer B	C00E	ITB	2	2	4
Implemented in BPU					
Memory Protect Enable	4003	MPEN	2	4	8
Load Memory Protect RAM	50XX	LMP	2	4	8
Read Memory Protect RAM	D0XX	RMP	2	3	3
Implemented in MMU					
Write Instruction Page Register	51XY	WIPR	2	4	8
Write Operand Page Register	52XY	WOPR	2	4	8
Read Memory Fault Status	A00D	RMFS	2	3	3
Read Instruction Page Register	D1XY	RIPR	2	3	3
Read Operand Page Register	D2XY	ROPR	2	3	3

*M = memory, P = processor (5 OSC cycles), B = processor (6 OSC cycles).
a = average if more than one alternative exists

Table 6b. Internal I/O Command Summary

6.0 Timing Characteristics

This section provides the detailed timing specifications for the MA17502. Figure 6 depicts the test load used to obtain timing data. Figures 7 through 9 depict the timing waveforms associated with various MA17502 signals. Table 7 provides values for parameters specified in the timing waveforms. All timing values provided in Table 7 are valid over the full military temperature range (-55°C to +125°C), and are measured from 50% point to 50% point (50% of VDD supply voltage, unless otherwise specified). Crosshatching in Figure 7 indicates either a "don't care" or indeterminate state.

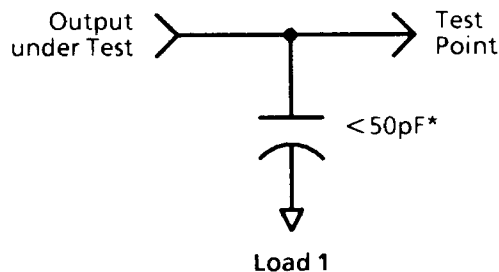

* Includes all jig and parasitic capacitance.

Figure 6. Test Load

No	Parameter	Test Condition ⁽¹⁾⁽²⁾	Min	Max	Units
1	CLKPC ↑ to Microword 1 Valid	Load 1	-	95	ns
2	CLK02 ↓ to Microword 2 Valid	Load 1	-	41	ns
3	Microword 1 after CLK02 ↓	Load 1	5	-	ns
4	Microword 2 after CLKPC ↓	Load 1	14	-	ns
5	AD Bus to CLKPC ↓	-	20	-	ns
6	T1 to CLKPC ↑	-	46	-	ns
7	PIF to CLKPC ↑	-	56	-	ns
8	IR to CLKPC ↑	-	47	-	ns
9	HOLD to CLKPC ↓	-	30	-	ns
10	RESET to CLKPC ↓	-	30	-	ns
11	AD Bus after CLKPC ↓	-	15	-	ns
12	HOLD after CLKPC ↓	-	15	-	ns
13	RESET after CLKPC ↓	-	15	-	ns
14	T1, PIF, IR after CLKPC ↓	-	0	-	ns

Notes:

- (1) -55°C and +125°C tested at VDD = 4.5V and 5.5V;
+25°C tested at VDD = 5.0V.
- (2) Unless otherwise noted: VIL ≥ 0.0V, VIH TTL ≤ 4.0V;
timing measured from 50% to 50% point.

Table 7a. Timing Parameter Values

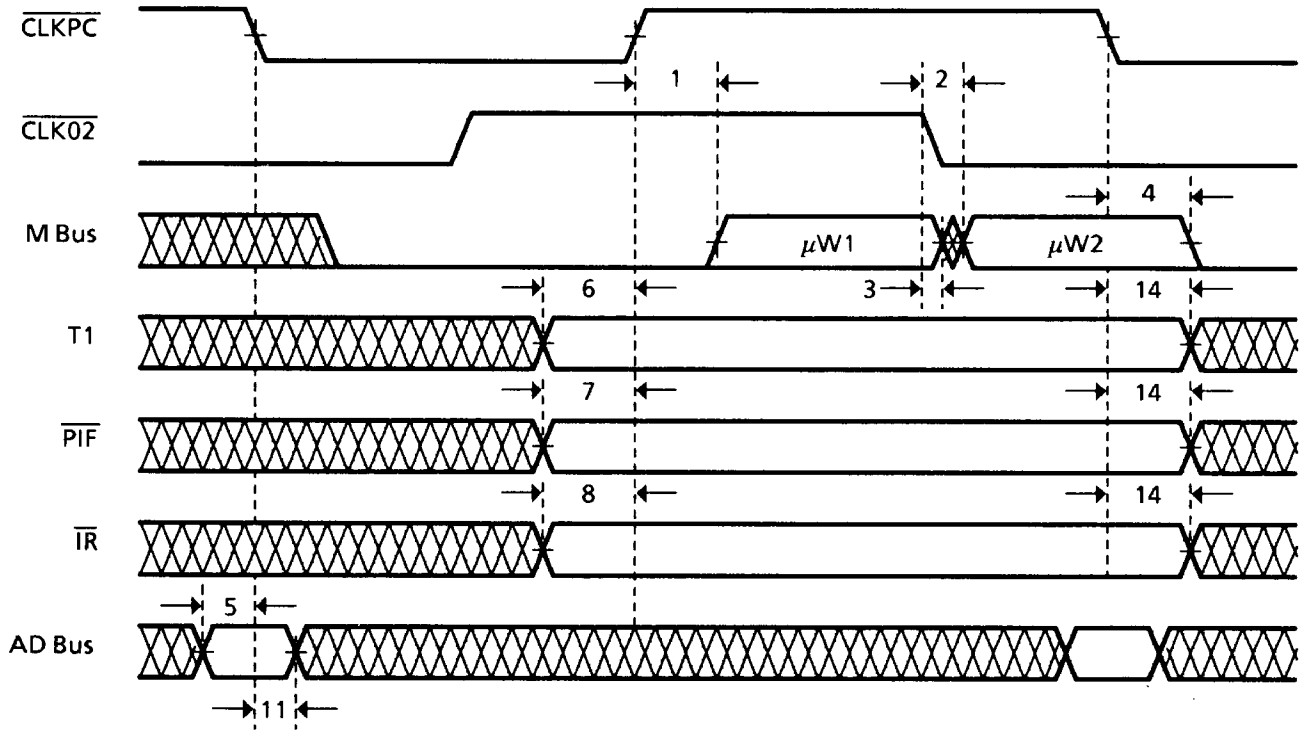

Note $\overline{\text{ROMONLY}}$ and CS are pulled up to VDD

Figure 7. Basic Timing

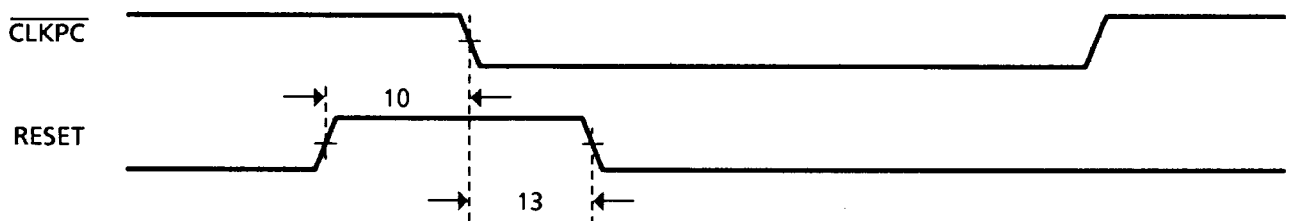

Figure 8. RESET Timing

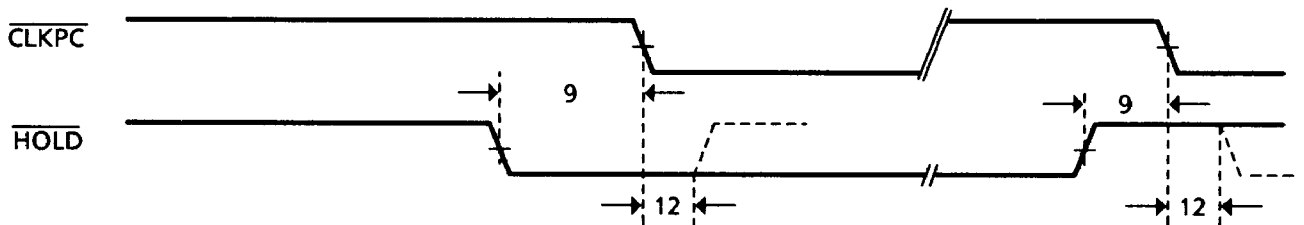

Figure 9. HOLD Timing

Radiation Hard MIL-STD-1750A Control Unit

7.0 Absolute Maximum Ratings

Parameter	Min	Max	Units
Supply voltage	-0.5	9	V
Input voltage	-0.3	$V_{DD} + 0.3$	V
Current through any pin	-20	20	mA
Operating temperature	-55	125	°C
Storage temperature	-65	150	°C

Stresses above those listed may cause permanent damage to the device. This is a stress rating only and functional operation of the device at these conditions, or at any other condition above those indicated in the operations section of this specification, is not implied. Exposure to absolute maximum rating conditions for extended periods may affect device reliability.

Table 8. Absolute Maximum Ratings

8.0 DC Electrical Characteristics

Symbol	Parameter	Condition	Total Dose Radiation Not Exceeding 3×10^5 RAD (Si)			Units
			Min.	Typ.	Max.	
V_{DD}	Supply voltage	-	4.5	5.0	5.5	V
V_{IH}	TTL Input High Voltage	-	2.0	-	-	V
V_{IL}	TTL Input Low Voltage	-	-	-	0.8	V
V_{OH}	TTL Output High Voltage	$I_{OH} = -1.4\text{mA}$	2.4	-	-	V
V_{OL}	TTL Output low Voltage	$I_{OL} = 2.0\text{mA}$	-	-	0.4	V
I_{IZ}	Input Leakage Current	$V_{DD} = 5.5\text{V}$	-	-	± 10	μA
I_{OZ}	Output Leakage Current	$V_{DD} = 5.5\text{V}$	-	-	± 20	μA
I_{DD}	Power Supply Current	$f = 20\text{MHz}$	-	-	120	mA

$V_{DD} = 5\text{V} \pm 10\%$, over full operating temperature range.

Table 9. Operating DC Electrical Characteristics

9.0 Packaging Information

Ceramic Dual-in-line - Package type C)

Ref.	Min.	Nom.	Max.
A			0.220
A ₁	0.015		0.060
b	0.014		0.023
c	0.008		0.014
D			3.232
e		0.100 typ.	
e ₁		0.900 typ.	
H	0.185		0.212
M _E			0.926

DIMENSIONS IN INCHES

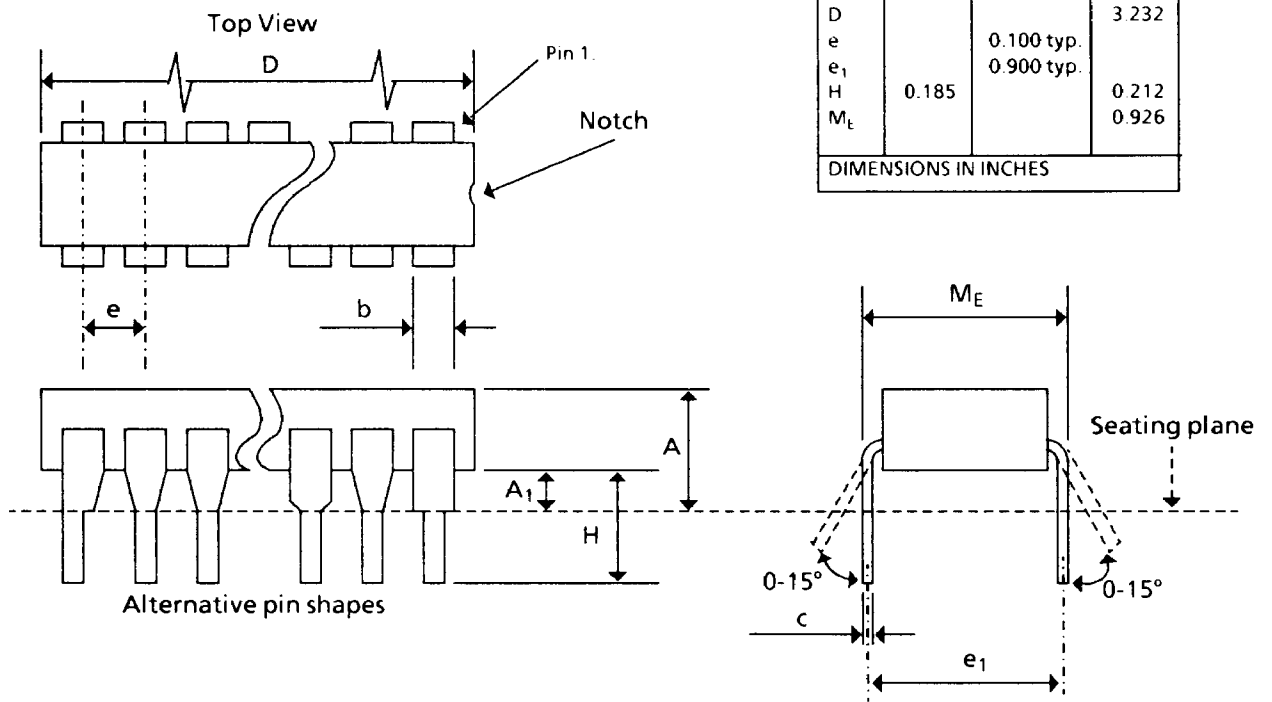

Figures 10a. Dimensioned Drawing

Radiation Hard MIL-STD-1750A Control Unit

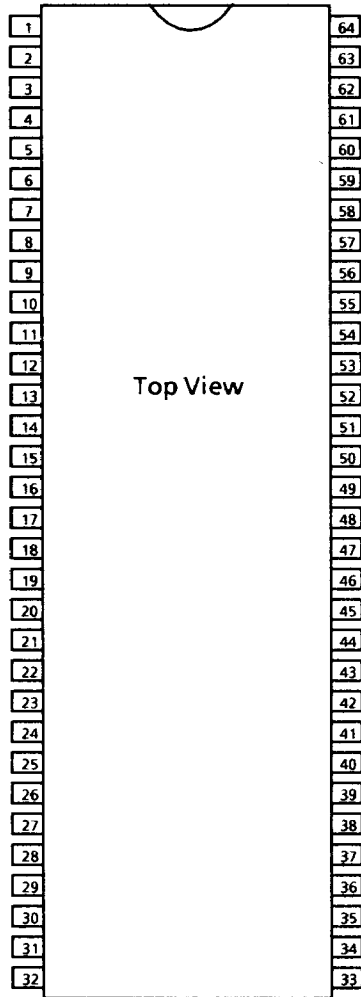

1	IRN	33	M08
2	VDD	34	NC
3	PIFN	35	M07
4	AD00	36	M06
5	AD01	37	M05
6	AD02	38	M04
7	AD03	39	M03
8	AD04	40	M02
9	AD05	41	M01
10	AD06	42	GND
11	AD07	43	CS
12	AD08	44	M00
13	AD09	45	CC00
14	AD10	46	CC01
15	AD11	47	CC02
16	AD12	48	CC03
17	AD13	49	CC04
18	AD14	50	CC05
19	AD15	51	CC06
20	CLK02N	52	CC07
21	CLKPCN	53	CC08
22	M19	54	CC09
23	M18	55	CC10
24	M17	56	CC11
25	M16	57	ROMONLYN
26	M15	58	NC
27	M14	59	GND
28	M13	60	NC
29	M12	61	NC
30	M11	62	T1
31	M10	63	RESET
32	M09	64	HOLDN

Figures 10b. Pin Assignments

Leadless Chip Carrier - Package type L

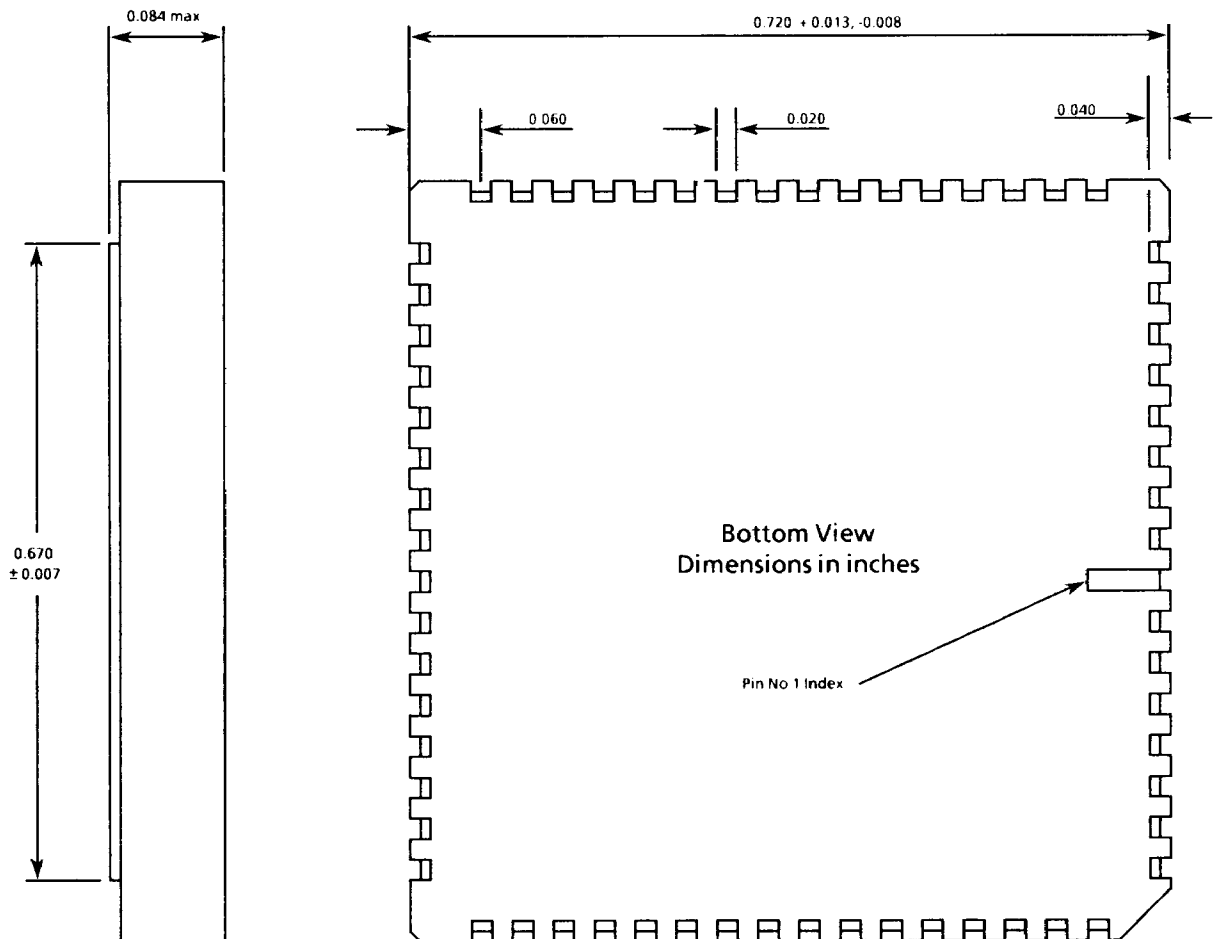

Figures 11a. Dimensioned Drawing

MA17502

Radiation Hard MIL-STD-1750A Control Unit

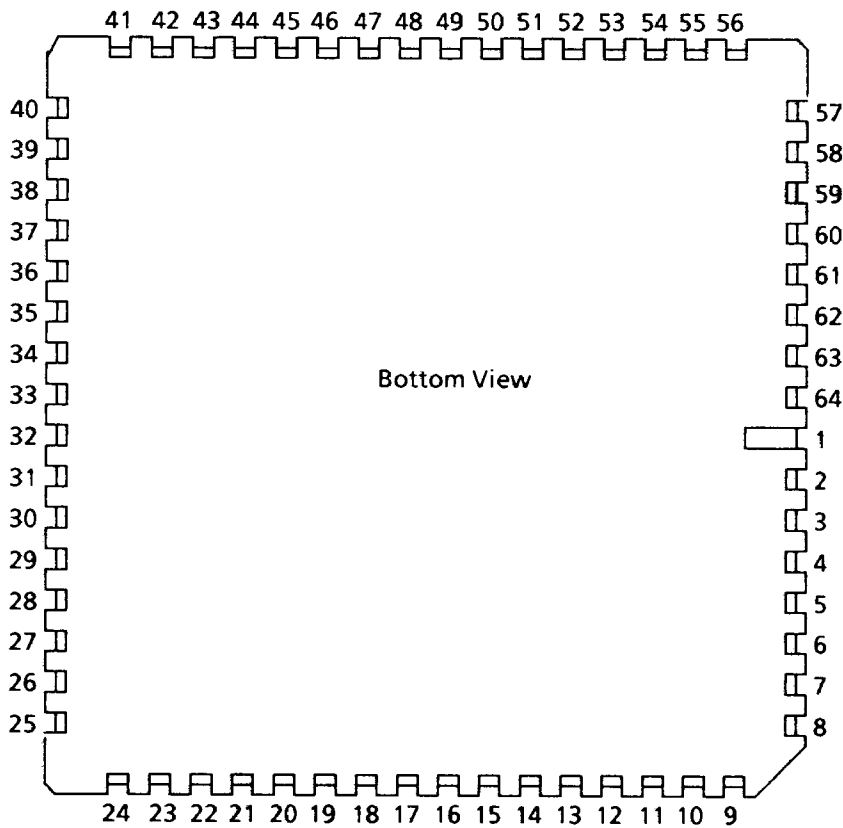

1	IRN	33	M08
2	VDD	34	NC
3	PIFN	35	M07
4	AD00	36	M06
5	AD01	37	M05
6	AD02	38	M04
7	AD03	39	M03
8	AD04	40	M02
9	AD05	41	M01
10	AD06	42	GND
11	AD07	43	CS
12	AD08	44	M00
13	AD09	45	CC00
14	AD10	46	CC01
15	AD11	47	CC02
16	AD12	48	CC03
17	AD13	49	CC04
18	AD14	50	CC05
19	AD15	51	CC06
20	CLK02N	52	CC07
21	CLKPCN	53	CC08
22	M19	54	CC09
23	M18	55	CC10
24	M17	56	CC11
25	M16	57	ROMONLYN
26	M15	58	NC
27	M14	59	GND
28	M13	60	NC
29	M12	61	NC
30	M11	62	T1
31	M10	63	RESET
32	M09	64	HOLDN

Figures 11b. Pin Assignments

MA17502

Radiation Hard
MIL-STD-1750A
Control Unit

Marconi
Electronic Devices

Topbraid Flatpack - Package type F

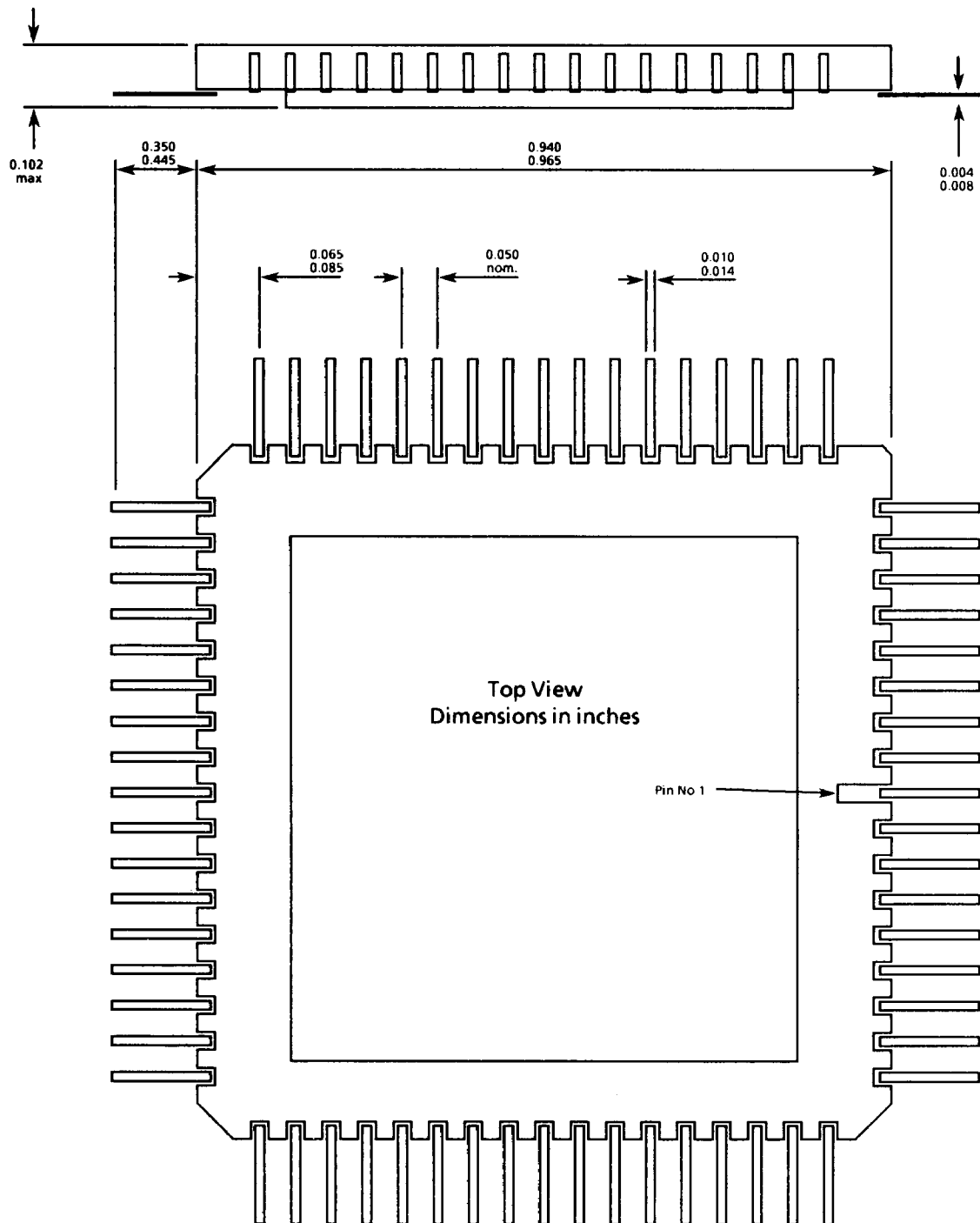

Figures 12a. Dimensioned Drawing

Radiation Hard
MIL-STD-1750A
Control Unit

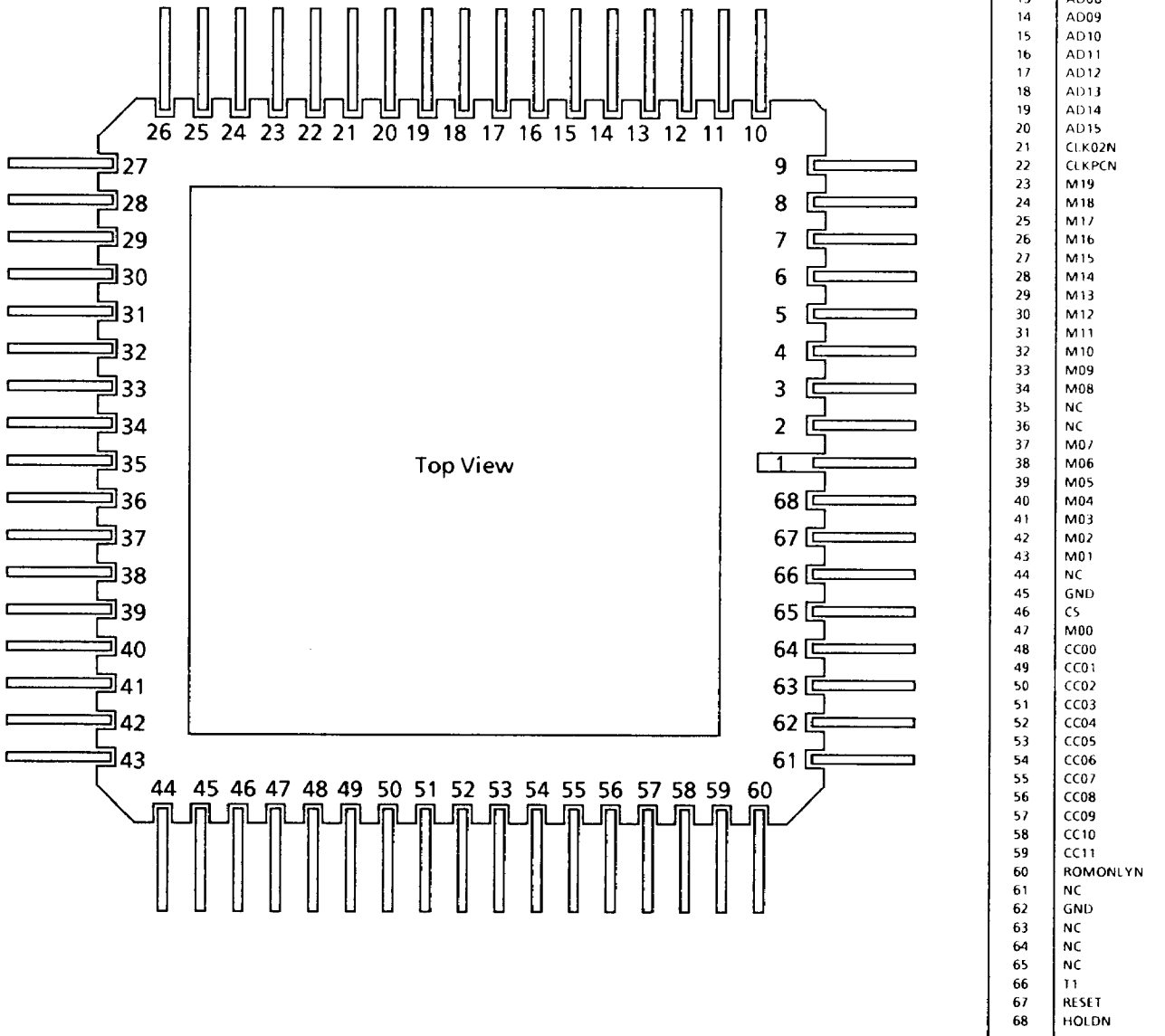

Figures 12b. Pin Assignments

Radiation Hard MIL-STD-1750A Control Unit

10.0 Total Dose Radiation Testing

For product procured to guaranteed total dose radiation levels, each wafer lot will be approved when all sample devices from each lot pass the total dose radiation test.

The sample devices will be subjected to the total dose radiation level (Cobalt-60 Source), defined by the ordering code, and must continue to meet the electrical parameters specified in the data sheet. Electrical tests, pre and post irradiation, will be read and recorded.

Total Dose (Function to specification, note 1)	3×10^5 Rad(Si)
Transient Upset (Stored data loss)	1×10^{10} Rad(Si)/s
Transient Upset (Survivability)	$> 1 \times 10^{12}$ Rad(Si)/s
Neutron Hardness (Function to specification)	1×10^{15} neutrons/cm ²
Latch-up	Not possible
Single Event Upset (note 2)	$< 10^{-10}$ errors/bit day

Note 1. Typical performance only, for guaranteed levels see ordering information .
2. GSO 10% Worst Case

11.0 Ordering Information

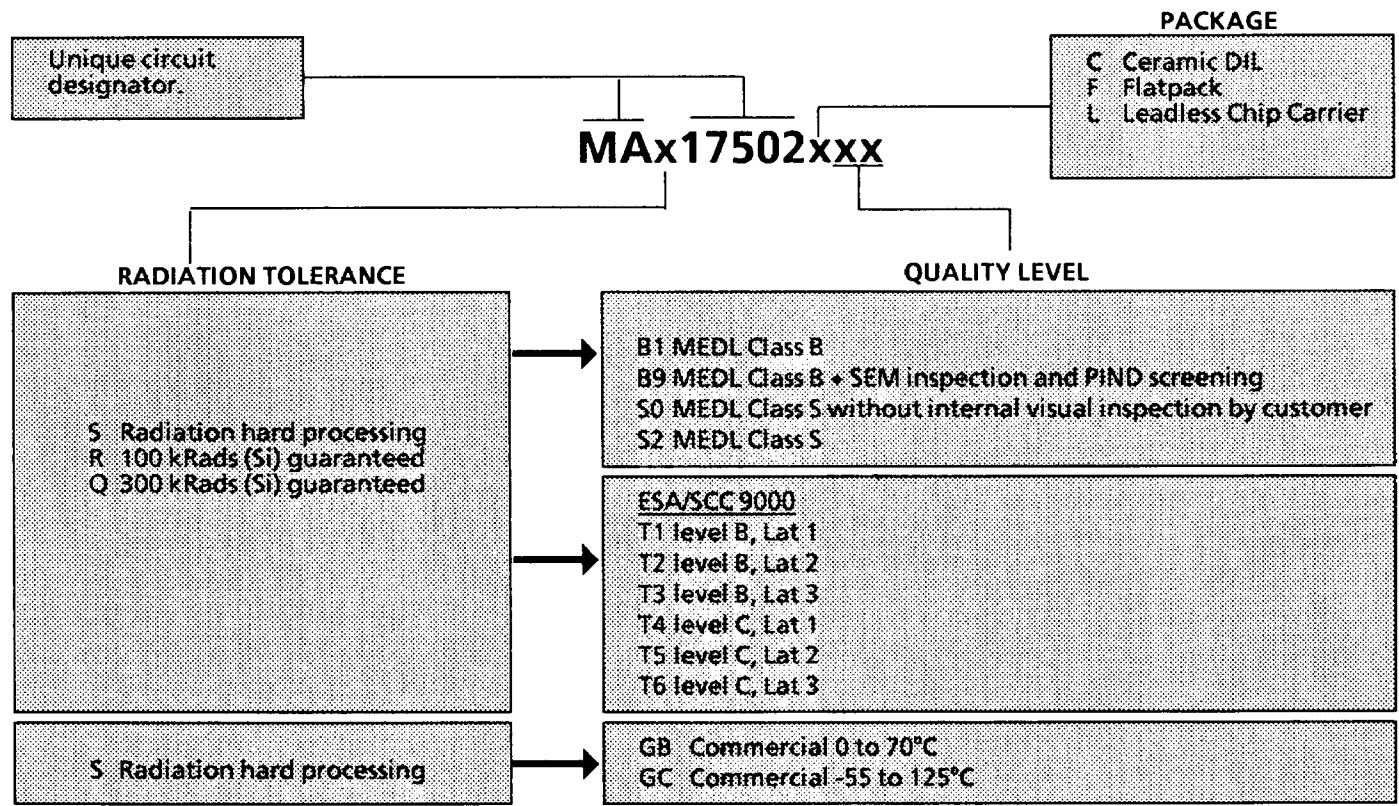

For details of quality levels, See Marconi Electronic Devices 'Quality Assurance Standards Document, 1'.