

SMJ320MCM42C, SMJ320MCM42D DUAL SMJ320C40 MULTICHIP MODULE

SGKS001D - JULY 1997 - REVISED OCTOBER 2001

- **Performance:**
 - 80 Million Floating-Point Operations Per Second (MFLOPS) With 496-Mbps-Burst I/O Rate for 40-MHz Modules
 - Zero-Wait-State Local Memory for Each Processor
- **Organization:**
 - 128K-Word × 32-Bit Static Random-Access Memory (SRAM) (SMJ320MCM42D)
 - 256K-Word × 32-Bit SRAM (SMJ320MCM42C)
- **Compliant With MIL-PRF-38535 QML**
- **Dual C40 Performance With Local Memory Requiring Only 8.7 Square Inches of Board Space**
- **Enhanced Performance Offered By Multichip-Module Solution**
 - SMJ320MCM42C
 - 67% Reduction in Number of Interconnects
 - 54% Reduction (Minimum) in Board Area
 - Estimated 38% Reduction in Power Dissipation Due to Reduced Parasitic Capacitance and Interconnect Lengths
 - SMJ320MCM42D
 - 56% Reduction in Number of Interconnects
 - 30% Reduction (Minimum) in Board Area
 - Estimated 20% Reduction in Power Dissipation Due to Reduced Parasitic Capacitance and Interconnect Lengths
- **Four Memory Ports for High Data Bandwidth**
 - Two Full 2G-Word External Buses
- **Two Internal Buses Mapped to Memory**
 - 128K-Word × 32-Bit SRAM for Each C40 Local Bus (SMJ320MCM42D)
 - 256K-Word × 32-Bit SRAM for Each C40 Local Bus (SMJ320MCM42C)
- **Ten External Communication Ports for Direct Processor-to-Processor Communication**

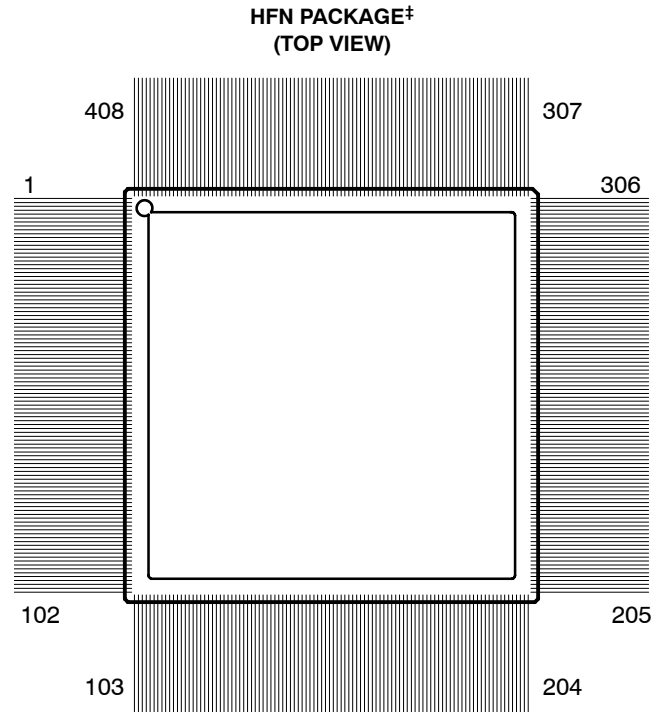

[‡] Terminal assignment information is provided by the terminal assignments table. Package is shown for pinout reference only.

- **IEEE-1149.1[†] (JTAG) Boundary-Scan Compatible**
- **408-Lead Ceramic Quad Flatpack Package (HFN Suffix)**
- **Operating Free-Air Temperature Ranges:**
 - 55°C to 125°C . . . (Military)
 - 0°C to 70°C . . . (Commercial)
- **Communication-Port Connection Provided Between C40s for Interprocessor Communication**



Please be aware that an important notice concerning availability, standard warranty, and use in critical applications of Texas Instruments semiconductor products and disclaimers thereto appears at the end of this data sheet.

[†] IEEE Standard 1149.1-1990 Standard Test-Access Port and Boundary-Scan Architecture

PRODUCTION DATA information is current as of publication date. Products conform to specifications per the terms of Texas Instruments standard warranty. Production processing does not necessarily include testing of all parameters.

 **TEXAS
INSTRUMENTS**

POST OFFICE BOX 1443 • HOUSTON, TEXAS 77251-1443

Copyright © 2001, Texas Instruments Incorporated
On products compliant to MIL-STD-PRF-38535, all parameters are tested unless otherwise noted. On all other products, production processing does not necessarily include testing of all parameters.

SMJ320MCM42C, SMJ320MCM42D DUAL SMJ320C40 MULTICHIP MODULE

SGKS001D - JULY 1997 - REVISED OCTOBER 2001

description

The 42 dual C40 multichip module (MCM) contains two SMJ320C40 digital signal processors (DSPs) with 128K words \times 32 bits (42D) or 256K words \times 32 bits (42C) of zero-wait-state SRAMs mapped to each local bus. Global address and data buses with two sets of control signals are routed externally for each processor, allowing external memory to be accessed. The external global bus provides a continuous address reach of 2G words.

The dual C40 configuration allows standard microprocessor initialization using the bootstrap loader. Both reset-vector-control terminals are brought out to external terminals for each processor. A single CLKIN line and a RESET line feed both processors in parallel, minimizing clock skew and allowing easy synchronization for interlocked operations.

Communication port 0 of CPU #1 connects to communication port 3 of CPU #2 for direct processor-to-processor communication.

The IEEE-1149.1 (JTAG) test ports of the C40s are connected serially to allow scan operations and emulation of the module as a whole. Testability of the 42 adds value and reduces development and support costs. Texas Instruments offers a wide variety of ANSI/IEEE-1149.1 products and support.

The 42 dual C40 MCM is packaged in a 408-pin ceramic quad flat pack. The 42 dual C40 MCM is available in both a commercial temperature range (0°C to 70°C) and a military temperature range (-55°C to 125°C) option.

For additional information when designing for cold temperature operation, please see Texas Instruments application report *320C3x, 320C4x and 320MCM42x Power-up Sensitivity at Cold Temperature*, literature number SGUA001.



SMJ320MCM42C, SMJ320MCM42D DUAL SMJ320C40 MULTICHIP MODULE

SGKS001D - JULY 1997 - REVISED OCTOBER 2001

device symbol nomenclature

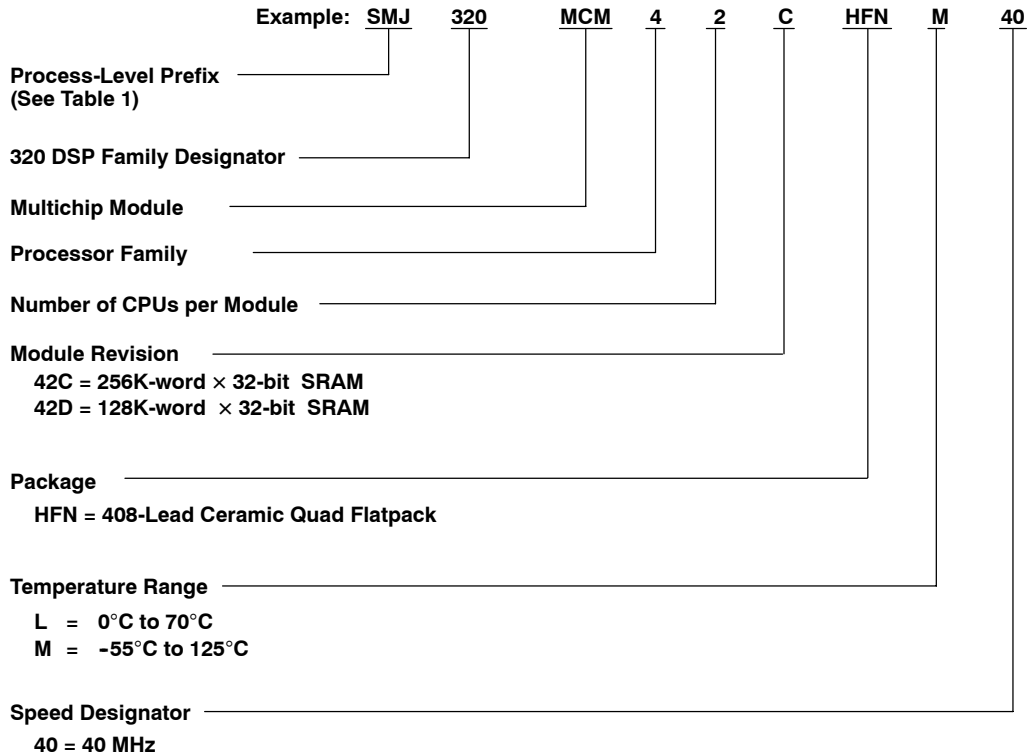

Table 1. MCM Processing Matrix

PROCESS LEVEL	TEMPERATURE RANGE		DIE	100% PROCESSED	SPEED TEST	TEST TEMPERATURE RANGE	QUALIFICATION TESTING
	L version	M version					
SM	L version	0°C to 70°C	Probed	No	No	25°C to 70°C	Package
	M version	-55°C to 125°C	Probed	No	Yes	-55°C to 125°C	Package
SMJ [†]	M version	-55°C to 125°C	KGD [‡]	Yes	Yes	-55°C to 125°C	MIL-H-38534

[†] SMJ-level product is full MIL-PRF-38535 QML compliant.

[‡] KGD stands for the known-good-die strategy as defined in the reference documentation section.



SMJ320MCM42C, SMJ320MCM42D DUAL SMJ320C40 MULTICHIP MODULE

SGKS001D - JULY 1997 - REVISED OCTOBER 2001

Terminal Assignments

NO.	TERMINAL NAME	NO.	TERMINAL NAME	NO.	TERMINAL NAME	NO.	TERMINAL NAME
1	ROMEN_C40_#1	52	A10_C40_#1	103	RDY1_C40_#2	154	C4D5_C40_#2
2	IIOF0_C40_#1	53	A9_C40_#1	104	VSS_DR	155	C4D4_C40_#2
3	IIOF1_C40_#1	54	A8_C40_#1	105	VSS_CL	156	C4D3_C40_#2
4	IIOF2_C40_#1	55	A7_C40_#1	106	LOCK_C40_#2	157	C4D2_C40_#2
5	IIOF3_C40_#1	56	A6_C40_#1	107	VCC_CL	158	C4D1_C40_#2
6	NMI_C40_#1	57	A5_C40_#1	108	VSS_CL	159	C4D0_C40_#2
7	VCC_DR	58	A4_C40_#1	109	CE0_C40_#2	160	VCC_DR
8	VSS_CL	59	VCC_DR	110	RDY0_C40_#2	161	VCC_DR
9	TCLK0_C40_#1	60	A3_C40_#1	111	DE_C40_#2	162	VSS_CL
10	TCLK1_C40_#1	61	A2_C40_#1	112	TCK_COMM	163	C2D7_C40_#2
11	H3_C40_#1	62	A1_C40_#1	113	TDO_C40_#2	164	C2D6_C40_#2
12	H1_C40_#1	63	A0_C40_#1	114	TMS_COMM	165	C2D5_C40_#2
13	VSS_CL	64	D31_C40_#2	115	TRST_COMM	166	C2D4_C40_#2
14	TACK_C40_#1	65	D30_C40_#2	116	EMU0_COMM	167	C2D3_C40_#2
15	CLKIN_COMM	66	D29_C40_#2	117	EMU1_COMM	168	C2D2_C40_#2
16	VCC_DR	67	D28_C40_#2	118	PAGE1_C40_#2	169	C2D1_C40_#2
17	VCC_CL	68	D27_C40_#2	119	R/W1_C40_#2	170	C2D0_C40_#2
18	VCC_DR	69	D26_C40_#2	120	STRB1_C40_#2	171	CRDY2_C40_#2
19	VSS_CL	70	VCC_DR	121	STAT0_C40_#2	172	CSTRB2_C40_#2
20	VSS_DR	71	D25_C40_#2	122	STAT1_C40_#2	173	CACK2_C40_#2
21	VCC_DR	72	D24_C40_#2	123	VSS_CL	174	CREQ2_C40_#2
22	VCC_DR	73	D23_C40_#2	124	STAT2_C40_#2	175	VCC_DR
23	VCC_CL	74	D22_C40_#2	125	STAT3_C40_#2	176	CRDY1_C40_#2
24	VSS_CL	75	D21_C40_#2	126	PAGE0_C40_#2	177	CSTRB1_C40_#2
25	VSS_DR	76	D20_C40_#2	127	R/W0_C40_#2	178	CACK1_C40_#2
26	VSS_CL	77	D19_C40_#2	128	STRB0_C40_#2	179	CREQ1_C40_#2
27	VCC_DR	78	D18_C40_#2	129	AE_C40_#2	180	CRDY0_C40_#2
28	A30_C40_#1	79	D17_C40_#2	130	RESETLOC1_C40_#2	181	CSTRB0_C40_#2
29	A29_C40_#1	80	D16_C40_#2	131	VCC_DR	182	CACK0_C40_#2
30	A28_C40_#1	81	VSS_CL	132	RESETLOC0_C40_#2	183	CREQ0_C40_#2
31	VCC_DR	82	VSS_CL	133	RESET_COMM	184	VSS_DR
32	A27_C40_#1	83	VCC_DR	134	CRDY5_C40_#2	185	VSS_CL
33	A26_C40_#1	84	VSS_DR	135	CSTRB5_C40_#2	186	VSS_DR
34	A25_C40_#1	85	D15_C40_#2	136	CACK5_C40_#2	187	VCC_DR
35	A24_C40_#1	86	D14_C40_#2	137	CREQ5_C40_#2	188	C1D7_C40_#2
36	A23_C40_#1	87	D13_C40_#2	138	CRDY4_C40_#2	189	C1D6_C40_#2
37	A22_C40_#1	88	D12_C40_#2	139	CSTRB4_C40_#2	190	C1D5_C40_#2
38	A21_C40_#1	89	D11_C40_#2	140	CACK4_C40_#2	191	C1D4_C40_#2
39	A20_C40_#1	90	D10_C40_#2	141	CREQ4_C40_#2	192	C1D3_C40_#2
40	A19_C40_#1	91	D9_C40_#2	142	VCC_DR	193	C1D2_C40_#2
41	A18_C40_#1	92	D8_C40_#2	143	C5D7_C40_#2	194	C1D1_C40_#2
42	A17_C40_#1	93	D7_C40_#2	144	C5D6_C40_#2	195	C1D0_C40_#2
43	VCC_DR	94	D6_C40_#2	145	C5D5_C40_#2	196	VCC_DR
44	VSS_CL	95	D5_C40_#2	146	C5D4_C40_#2	197	C0D7_C40_#2
45	VSS_DR	96	VCC_DR	147	C5D3_C40_#2	198	C0D6_C40_#2
46	A16_C40_#1	97	D4_C40_#2	148	C5D2_C40_#2	199	C0D5_C40_#2
47	A15_C40_#1	98	D3_C40_#2	149	C5D1_C40_#2	200	C0D4_C40_#2
48	A14_C40_#1	99	D2_C40_#2	150	C5D0_C40_#2	201	C0D3_C40_#2
49	A13_C40_#1	100	D1_C40_#2	151	VCC_DR	202	C0D2_C40_#2
50	A12_C40_#1	101	D0_C40_#2	152	C4D7_C40_#2	203	C0D1_C40_#2
51	A11_C40_#1	102	CE1_C40_#2	153	C4D6_C40_#2	204	C0D0_C40_#2



SMJ320MCM42C, SMJ320MCM42D DUAL SMJ320C40 MULTICHIP MODULE

SGKS001D - JULY 1997 - REVISED OCTOBER 2001

Terminal Assignments (Continued)

TERMINAL NO.	TERMINAL NAME	TERMINAL NO.	TERMINAL NAME	TERMINAL NO.	TERMINAL NAME	TERMINAL NO.	TERMINAL NAME
205	ROMEN_C40_#2	256	A9_C40_#2	307	V _{SS} _DR	358	V _{SS} _DR
206	IIOF0_C40_#2	257	A8_C40_#2	308	V _{SS} _CL	359	V _{CC} _DR
207	IIOF1_C40_#2	258	A7_C40_#2	309	LOCK_C40_#1	360	C3D7_C40_#1
208	IIOF2_C40_#2	259	A6_C40_#2	310	V _{CC} _CL	361	C3D6_C40_#1
209	IIOF3_C40_#2	260	A5_C40_#2	311	V _{SS} _CL	362	C3D5_C40_#1
210	NMI_C40_#2	261	A4_C40_#2	312	CE0_C40_#1	363	C3D4_C40_#1
211	V _{CC} _DR	262	V _{CC} _DR	313	RDY0_C40_#1	364	C3D3_C40_#1
212	V _{SS} _CL	263	A3_C40_#2	314	DE_C40_#1	365	C3D2_C40_#1
213	TCLK0_C40_#2	264	A2_C40_#2	315	TDI_C40_#1	366	C3D1_C40_#1
214	TCLK1_C40_#2	265	A1_C40_#2	316	PAGE1_C40_#1	367	C3D0_C40_#1
215	H3_C40_#2	266	A0_C40_#2	317	R/W1_C40_#1	368	V _{CC} _DR
216	H1_C40_#2	267	D31_C40_#1	318	STRB1_C40_#1	369	V _{SS} _CL
217	V _{SS} _CL	268	D30_C40_#1	319	STAT0_C40_#1	370	C2D7_C40_#1
218	IACK_C40_#2	269	D29_C40_#1	320	STAT1_C40_#1	371	C2D6_C40_#1
219	V _{CC} _DR	270	D28_C40_#1	321	V _{SS} _CL	372	C2D5_C40_#1
220	V _{CC} _DR	271	D27_C40_#1	322	STAT2_C40_#1	373	C2D4_C40_#1
221	V _{CC} _DR	272	D26_C40_#1	323	STAT3_C40_#1	374	C2D3_C40_#1
222	V _{SS} _CL	273	V _{CC} _DR	324	PAGE0_C40_#1	375	C2D2_C40_#1
223	V _{SS} _DR	274	D25_C40_#1	325	R/W0_C40_#1	376	C2D1_C40_#1
224	V _{CC} _DR	275	D24_C40_#1	326	STRB0_C40_#1	377	C2D0_C40_#1
225	V _{CC} _DR	276	D23_C40_#1	327	AE_C40_#1	378	V _{SS} _DR
226	V _{CC} _CL	277	D22_C40_#1	328	RESETLOC1_C40_#1	379	V _{CC} _DR
227	V _{SS} _CL	278	D21_C40_#1	329	V _{CC} _DR	380	CRDY3_C40_#1
228	V _{SS} _DR	279	D20_C40_#1	330	RESETLOC0_C40_#1	381	CSTRB3_C40_#1
229	V _{SS} _CL	280	D19_C40_#1	331	CRDY5_C40_#1	382	CACK3_C40_#1
230	V _{CC} _DR	281	D18_C40_#1	332	CSTRB5_C40_#1	383	CREQ3_C40_#1
231	A30_C40_#2	282	D17_C40_#1	333	CACK5_C40_#1	384	V _{CC} _CL
232	A29_C40_#2	283	D16_C40_#1	334	CREQ5_C40_#1	385	V _{SS} _CL
233	A28_C40_#2	284	V _{SS} _CL	335	CRDY4_C40_#1	386	CRDY2_C40_#1
234	V _{CC} _DR	285	V _{SS} _CL	336	CSTRB4_C40_#1	387	CSTRB2_C40_#1
235	A27_C40_#2	286	V _{CC} _DR	337	CACK4_C40_#1	388	CACK2_C40_#1
236	A26_C40_#2	287	V _{SS} _DR	338	CREQ4_C40_#1	389	CREQ2_C40_#1
237	A25_C40_#2	288	D15_C40_#1	339	V _{SS} _DR	390	V _{CC} _DR
238	A24_C40_#2	289	D14_C40_#1	340	V _{CC} _DR	391	CRDY1_C40_#1
239	A23_C40_#2	290	D13_C40_#1	341	C5D7_C40_#1	392	CSTRB1_C40_#1
240	A22_C40_#2	291	D12_C40_#1	342	C5D6_C40_#1	393	CACK1_C40_#1
241	A21_C40_#2	292	D11_C40_#1	343	C5D5_C40_#1	394	CREQ1_C40_#1
242	A20_C40_#2	293	D10_C40_#1	344	C5D4_C40_#1	395	V _{SS} _DR
243	A19_C40_#2	294	D9_C40_#1	345	C5D3_C40_#1	396	V _{SS} _CL
244	A18_C40_#2	295	D8_C40_#1	346	C5D2_C40_#1	397	V _{SS} _DR
245	A17_C40_#2	296	D7_C40_#1	347	C5D1_C40_#1	398	V _{CC} _DR
246	V _{CC} _DR	297	D6_C40_#1	348	C5D0_C40_#1	399	C1D7_C40_#1
247	V _{SS} _CL	298	D5_C40_#1	349	V _{CC} _DR	400	C1D6_C40_#1
248	V _{SS} _DR	299	V _{CC} _DR	350	C4D7_C40_#1	401	C1D5_C40_#1
249	A16_C40_#2	300	D4_C40_#1	351	C4D6_C40_#1	402	C1D4_C40_#1
250	A15_C40_#2	301	D3_C40_#1	352	C4D5_C40_#1	403	C1D3_C40_#1
251	A14_C40_#2	302	D2_C40_#1	353	C4D4_C40_#1	404	C1D2_C40_#1
252	A13_C40_#2	303	D1_C40_#1	354	C4D3_C40_#1	405	C1D1_C40_#1
253	A12_C40_#2	304	D0_C40_#1	355	C4D2_C40_#1	406	C1D0_C40_#1
254	A11_C40_#2	305	CE1_C40_#1	356	C4D1_C40_#1	407	V _{CC} _DR
255	A10_C40_#2	306	RDY1_C40_#1	357	C4D0_C40_#1	408	V _{SS} _DR



SMJ320MCM42C, SMJ320MCM42D DUAL SMJ320C40 MULTICHIP MODULE

SGKS001D - JULY 1997 - REVISED OCTOBER 2001

functional block diagram

The following terminals have 10-k Ω pullup resistors added within the module:

- $\overline{\text{CREQ}}_x_C40_ \#1$, $\overline{\text{CACK}}_x_C40_ \#1$, $\overline{\text{CSTRB}}_x_C40_ \#1$, $\overline{\text{CRDY}}_x_C40_ \#1$, where x = 1, 2, 3, 4, or 5
- $\overline{\text{CREQ}}_y_C40_ \#2$, $\overline{\text{CACK}}_y_C40_ \#2$, $\overline{\text{CSTRB}}_y_C40_ \#2$, $\overline{\text{CRDY}}_y_C40_ \#2$, where y = 0, 1, 2, 4, or 5
- $\overline{\text{LCE}}1_C40_ \#1$, $\overline{\text{LCE}}2_C40_ \#2$ (internal connections)

A total of 18 decoupling capacitors have been connected within the module.

Between clean power and ground, the following capacitors have been connected:

- Two 0.1- μF capacitors
- Two 0.01- μF capacitors

Between dirty power and ground, the following capacitors have been connected:

- Twelve 0.1- μF capacitors
- Two 0.01- μF capacitors



SMJ320MCM42C, SMJ320MCM42D DUAL SMJ320C40 MULTICHIP MODULE

SGKS001D - JULY 1997 - REVISED OCTOBER 2001

functional block diagram (continued)

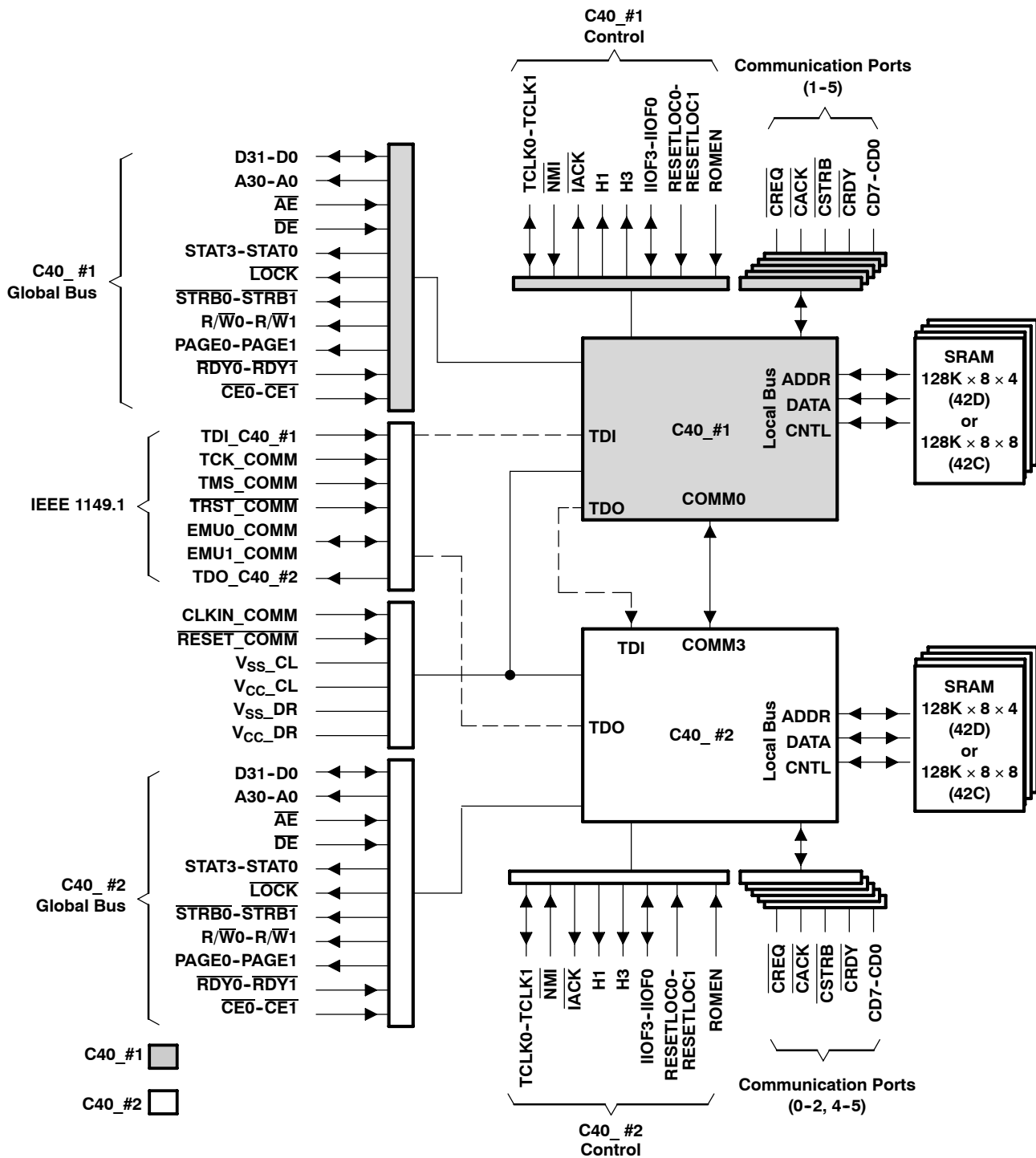

SMJ320MCM42C, SMJ320MCM42D DUAL SMJ320C40 MULTICHIP MODULE

SGKS001D - JULY 1997 - REVISED OCTOBER 2001

operational overview

Treatment of the detailed operation of the C40 device is not included in the scope of this document. See the *TMS320C4x User's Guide* (literature number SPRU063) for a detailed description of this DSP. See Figure 1 and Figure 2 for the memory map.

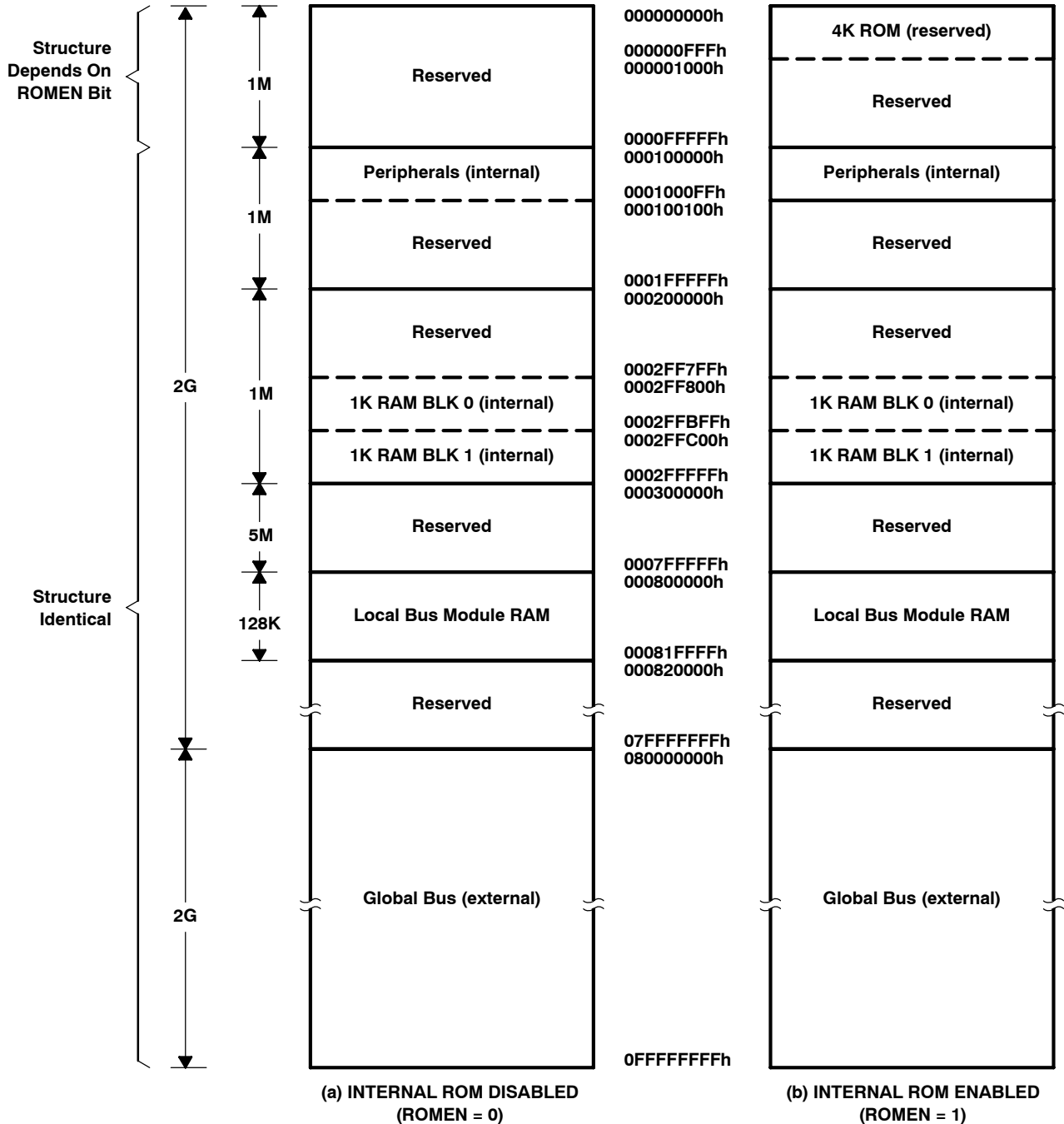

Figure 1. Memory Map for Each C40 Within the Multichip Module (42D)

SMJ320MCM42C, SMJ320MCM42D DUAL SMJ320C40 MULTICHIP MODULE

SGKS001D - JULY 1997 - REVISED OCTOBER 2001

operational overview (continued)

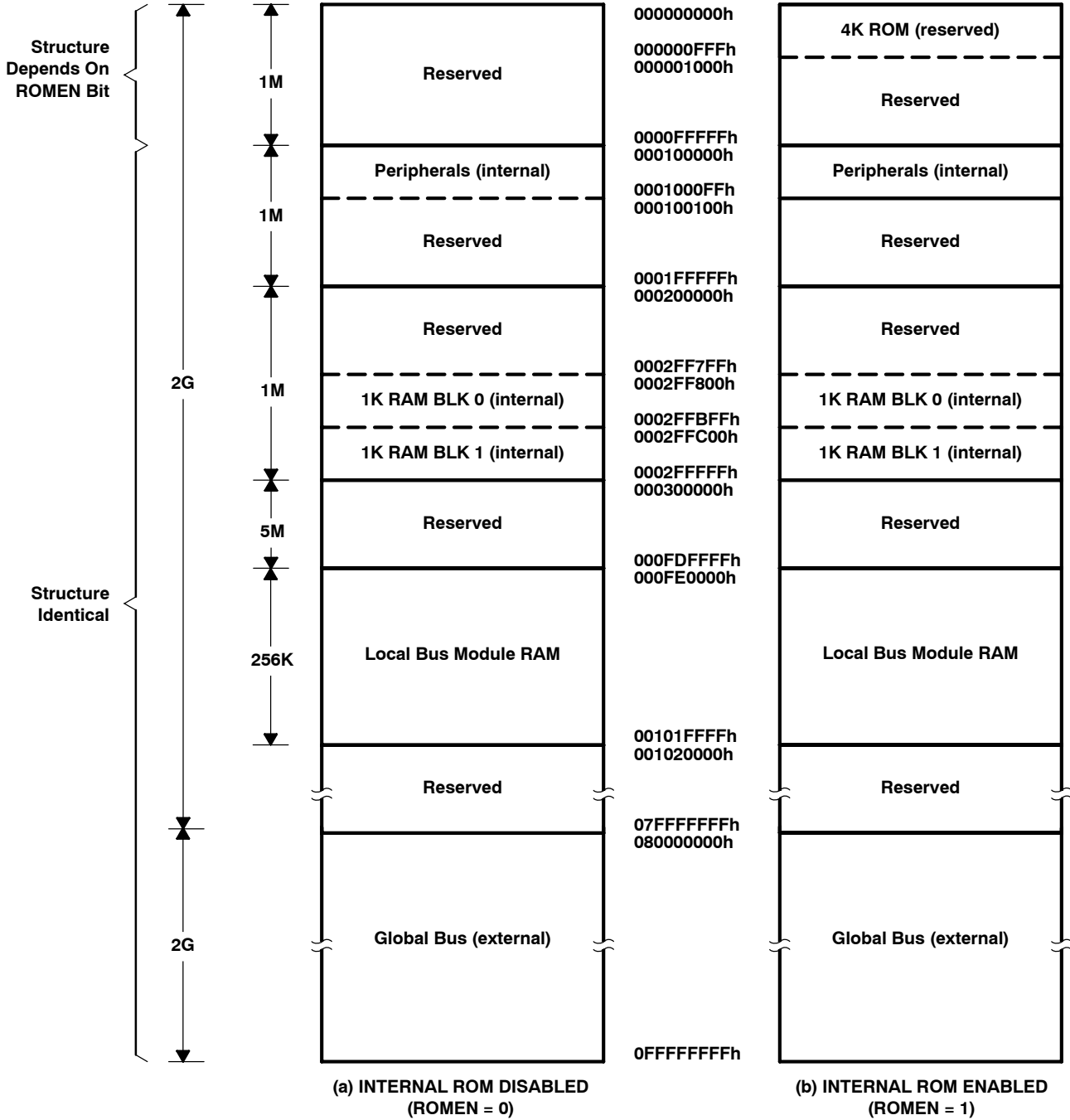

Figure 2. Memory Map for Each C40 Within the Multichip Module (42C)

SMJ320MCM42C, SMJ320MCM42D DUAL SMJ320C40 MULTICHIP MODULE

SGKS001D - JULY 1997 - REVISED OCTOBER 2001

application note

For all MCM42x product manufactured prior to August 1, 2001 (i.e., date codes older than 0131), users should reference the application note on page 10 of SGKS001B (July 1997 - Revised February 2000) for proper memory function.

The following application note applies to MCM42x product manufactured after August 1, 2001 (i.e., date codes newer than 0131). Changes to this application note from the previous data sheet revision impact the MCM42C only. Note: The information for the MCM42D below remains unchanged regardless of the date code.

For all MCM42C, the location of the local memory is different from that of the MCM42D. In addition, for proper use of the memory, it is necessary to understand how the memory is controlled.

For product manufactured with date codes newer than 0131, the following applies to the MCM42C only: The entire memory array is controlled by $\overline{\text{LSTRB0}}$. The value to be loaded to the STRB ACTIVE area (bits 28–24) should be 11110 (binary). This will require a code change for customers who developed code intended for use with MCM42C devices manufactured with date codes older than 0131.

For the MCM42D, $\overline{\text{LSTRB0}}$ controls the entire 128K. The default value loaded into the STRB ACTIVE area of the LMICR after reset is sufficient to control the memory. The default value is 11110, and tells the C40 that the entire local memory is controlled by $\overline{\text{LSTRB0}}$.

This subject is discussed in depth in Chapter 9 of the *1996 TMS320C4x User's Guide* (literature number SPRU063). In particular, section 9.3 discusses the proper use of the memory interface control registers.

reference documentation and data sheet scope

The SMJ320MCM42 is qualified to MIL-PRF-38535. Electrical continuity of the module is ensured through the use of IEEE-1149.1-compatible boundary-scan testing and functional checkout of the local SRAM space.

KGD refers to TI known-good-die strategy. TI KGDs are fully tested over the military temperature range per MIL-PRF-38535 QML. Electrical tests ensure compliance of the C40 KGD components to the SMJ320C40 data sheet (literature number SGUS017) over the operating temperature range. Module timings are virtually unchanged from the SMJ320C40 data sheet timings. An SMJ320C40 data sheet is provided for customer reference only and does not imply MCM compliance to published timings.

For a description of the C40 operation and application information, see the *TMS320C4x User's Guide* (literature number SPRU063).



SMJ320MCM42C, SMJ320MCM42D DUAL SMJ320C40 MULTICHIP MODULE

SGKS001D - JULY 1997 - REVISED OCTOBER 2001

absolute maximum ratings over operating free-air temperature range (unless otherwise noted)[†]

Supply voltage range, V_{CC} (see Note 1)	- 0.3 V to 7 V
Voltage range on any terminal	- 0.3 V to 7 V
Output voltage range, V_O	- 0.3 V to 7 V
Operating free-air temperature range (commercial [L version]), T_A	0°C to 70°C
(military [M version]), T_A	- 55°C to 125°C
Junction temperature, T_J	150°C
Storage temperature range, T_{stg}	- 65°C to 150°C

[†] Stresses beyond those listed under “absolute maximum ratings” may cause permanent damage to the device. These are stress ratings only, and functional operation of the device at these or any other conditions beyond those indicated under “recommended operating conditions” is not implied. Exposure to absolute-maximum-rated conditions for extended periods may affect device reliability.

NOTE 1: All voltage values are with respect to V_{SS} .

recommended operating conditions

		MIN	MAX	UNIT
V_{CC}	Supply voltage	42-33	4.5 5.5	V
		42-40	4.75 5.25	
V_{IH}	High-level input voltage	CLKIN_COMM	2.6 $V_{CC} + 0.3$	V
		CSTRBx, CRDYx, CREQx, CACKx	2.2 $V_{CC} + 0.3$	
		All others	2 $V_{CC} + 0.3$	
V_{IL}	Low-level input voltage	- 0.3	0.8	V
I_{OH}	High-level output current		- 300	μ A
I_{OL}	Low-level output current		2	mA
T_A	Operating free-air temperature range	L version	0 70	°C
		M version	- 55 125	

electrical characteristics over recommended ranges of supply voltage and operating free-air temperature (see Note 2)

PARAMETER		TEST CONDITIONS [†]	MIN	TYP	MAX	UNIT
V_{OH}	High-level output voltage	$V_{CC} = \text{MIN}, I_{OH} = \text{MAX}$	2.4	3		V
V_{OL}	Low-level output voltage	$V_{CC} = \text{MIN}, I_{OL} = \text{MAX}$		0.3	0.6	V
I_{CC}	Supply current	42D		0.7	1.1	A
		42C	$V_{CC} = \text{MAX}$	0.8	1.5	
I_Z	3-state current	$V_I = V_{SS} \text{ to } V_{CC}$	- 20		20	μ A
I_I	Input current	$V_I = V_{SS} \text{ to } V_{CC}$	- 10		10	μ A
I_{I2}	Input current, COMM signal (see Note 3)	$V_I = V_{SS} \text{ to } V_{CC}$	- 20		20	μ A
I_{IP}	Input current, internal pullup (see Note 4)	$V_I = V_{SS} \text{ to } V_{CC}$	- 400		30	μ A
I_{IP2}	Input current, dual internal pullup (see Note 5)	$V_I = V_{SS} \text{ to } V_{CC}$	- 800		60	μ A
I_{IC}	Input current, CLKIN_COMM	$V_I = V_{SS} \text{ to } V_{CC}$	- 60		60	μ A

[†] For conditions shown as MIN/MAX, use the appropriate value specified under recommended operating conditions.

NOTES: 2. Electrical characteristics are calculated algebraically from the SMJ320C40 data sheet limits.

3. Includes signals EMU0_COMM, EMU1_COMM, and RESET_COMM

4. Applies to TDI_C40_#1

5. Includes signals TCK_COMM, TMS_COMM, and TRST_COMM



SMJ320MCM42C, SMJ320MCM42D

DUAL SMJ320C40 MULTICHIP MODULE

SGKS001D - JULY 1997 - REVISED OCTOBER 2001

capacitance

Capacitance of a C40 die is specified by design to be 15 pF maximum for both inputs and outputs. Module networks add up to 5 pF. Characterization of die or substance capacitance is performed after any design change. Power measurements taken for a C40 die are made with an additional 80-pF load capacitance. Refer to the SMJ320C40 data sheet (literature number SGUS017) for the test load circuit.

operational timings and module testing

Texas Instruments processing assures that operation is verified to published data sheet specifications on the C40 in die form. All voltage, timing, speed, and temperature specifications are met before any die is placed into a multichip module. For this reason, all C40 voltage and timing parameters at the module level need not be verified.

Characterization of the 42 substrate shows that the module performs as an equivalent system of discretely packaged C40 devices. This performance is assured through a full-frequency functional checkout of the module that verifies selected worst-case timings. An additional propagation delay is introduced by the substrate. This value is assured by design to be less than 1 ns, but it is not tested. See the SMJ320C40 data sheet (literature number SGUS017) for a complete listing of timing diagrams and limits.

module test capability (future compatibility)

The C40 supports the IEEE-1149.1 testability standard, and the test access port (TAP) is brought out to the module footprint. TDI is connected to C40_#1, TDO of C40_#1 is connected to TDI of C40_#2, and TDO of C40_#2 is brought out to the TAP. TCK_COMM, TMS_COMM, and TRST_COMM are routed to both C40s in the module. This configuration allows users to test the module using third-party JTAG testability tools or other boundary-scan control software. Proper software configuration allows users to debug or launch code on the module by way of the C40 emulator and extended development system (XDS™) pod. Both of these tools are used as part of outgoing module testing.

The 42 supports third-party JTAG diagnostic families of products for verification and debug of boundary-scan circuits, boards, and systems. Further information on JTAG testability tools is available through any TI sales representative or authorized TI distributor.

XDS is a trademark of Texas Instruments Incorporated.



module test circuit

Figure 3 illustrates the basic circuits for the 42. See the *TMS320C4x User's Guide* (literature number SPRU063) for more detailed information.

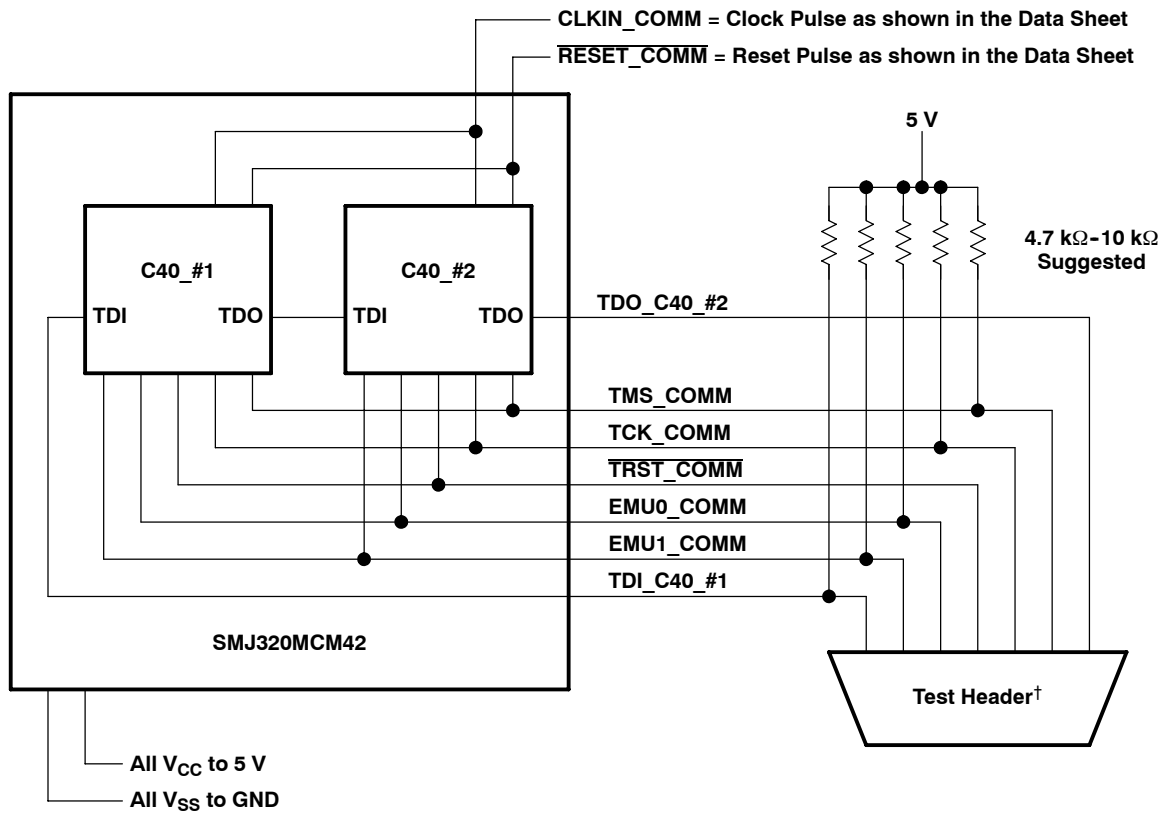

[†] The test header normally consists of the XDS510™ for the C40 emulation or ASSET hardware for interconnect testing.

Figure 3. Sample Test Circuit

SMJ320MCM42C, SMJ320MCM42D

DUAL SMJ320C40 MULTICHIP MODULE

SGKS001D - JULY 1997 - REVISED OCTOBER 2001

thermal analysis

Thermal conduction of components in the SMJ320MCM42 is dependent on thermal resistance of the material under each die as well as die area thermally connected to the heat-dissipating medium. Since these properties vary with layout and die size, C40 and SRAM components should be considered separately. Table 2 lists primary parameters required for thermal analysis of the module. T_J , the maximum junction temperature, is not to be exceeded for the C40s or the SRAM die.

Table 2. Thermal Characteristics

PARAMETER		MIN	TYP	MAX	UNIT
T_J	Maximum allowable junction temperature under operating condition			150	°C
P_{MCM}	Module power dissipation		3.5	5.8	W
$T_{JC_pkg}^\dagger$	Average thermal impedance (junction to case) for the package		2.1		°C/W
T_{JA}	Thermal impedance (junction to ambient air, 0 cfm) of package		20.5		°C/W
T_{SOL}	Maximum solder temperature (10 s duration)			260	°C

[†] T_{JC} package data was taken under the following conditions: two C40s dissipating 1.05 W each and eight SRAMs dissipating 0.175 W each.

power estimation

During the operation verification, the power requirements of the SMJ320MCM42 are characterized over the operating free-air temperature range. See the application report *Calculation of TMS320C40 Power Dissipation* (literature number SPRA032) as reference for power estimation of the C40 components.

Typical power dissipation is measured with both C40s executing a 64-point fast Fourier transform (FFT) algorithm. Input and output data arrays reside in module SRAM, and output data is written out to the global-address space. The global databus is loaded with 80-pF test loads, and both local and global writes are configured for zero-wait-state memory. Under typical conditions of 25°C, 5-V V_{CC} , and 40-MHz CLKIN frequency, the power dissipation is measured to be 3.5 W.

Maximum power dissipation is measured under worst-case conditions. The global databus is loaded with 80-pF test loads, and simultaneous zero-wait-state writes are performed to both local and global buses. Under worst-case environment conditions of -55°C, 5.25-V V_{CC} , and 40-MHz CLKIN frequency, the power dissipation is determined to be 5.9 W. The algorithm executed during these tests consists of parallel writes of alternating 0xAAs and 0x55s to both local SRAM and global-address spaces. This algorithm is not considered to be a practical use of the C40's resources; therefore, the associated power measurement must be considered absolute maximum only.



**SMJ320MCM42C, SMJ320MCM42D
DUAL SMJ320C40 MULTICHIP MODULE**

SGKS001D - JULY 1997 - REVISED OCTOBER 2001

MECHANICAL DATA

HFN (S-CQFP-F408)

CERAMIC QUAD FLATPACK WITH TIE-BAR

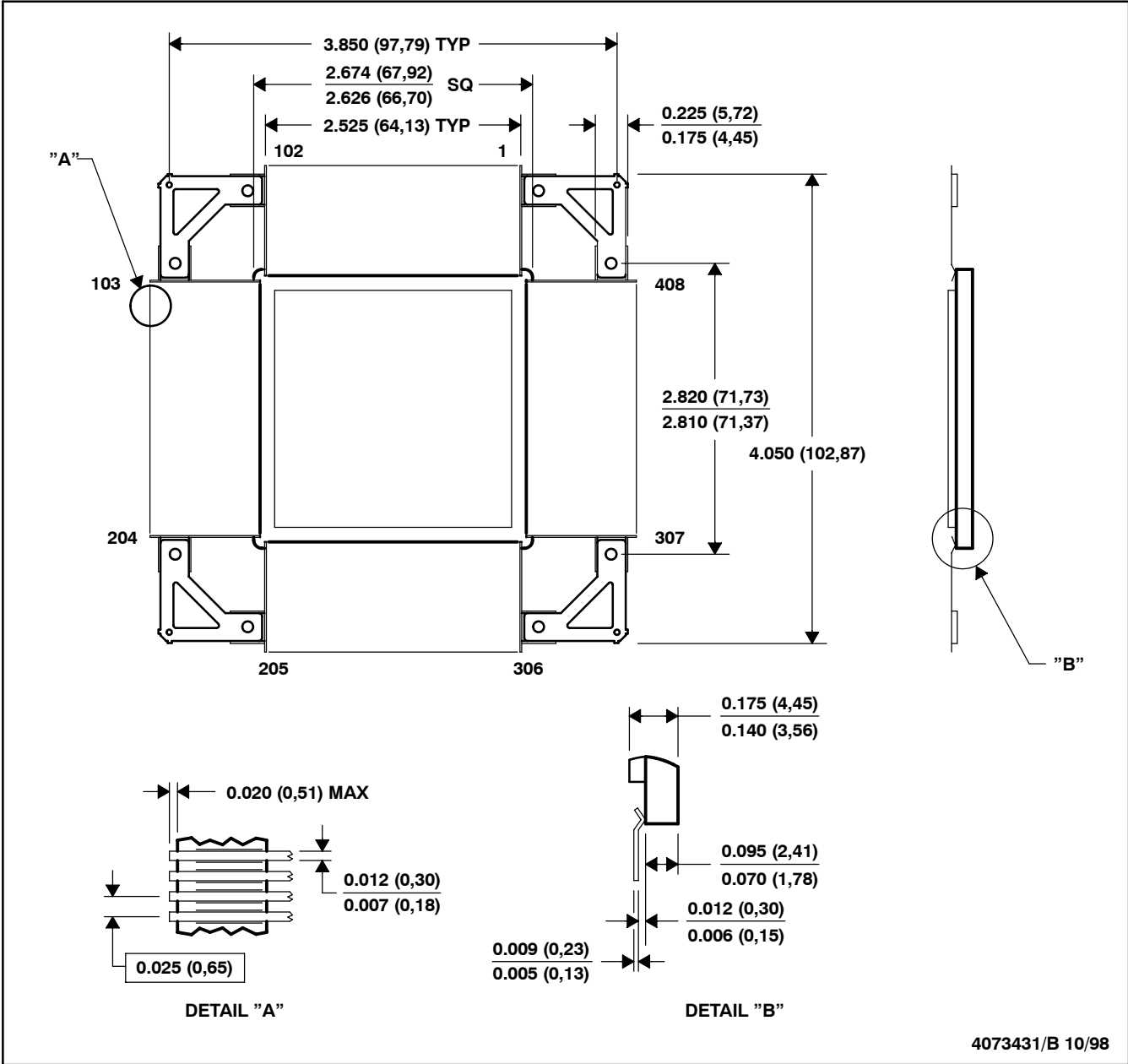

NOTES: A. All linear dimensions are in inches (millimeters).
B. This drawing is subject to change without notice.



PACKAGING INFORMATION

Orderable Device	Status (1)	Package Type	Package Drawing	Pins	Package Qty	Eco Plan (2)	Lead/Ball Finish (6)	MSL Peak Temp (3)	Op Temp (°C)	Device Marking (4/5)	Samples
5962-9678901QXC	OBSOLETE	CFP	HFN	408		TBD	Call TI	Call TI	-55 to 125	5962-9678901QX C SMJ320MCM42DHF NM40	
SMJ320MCM42DHFNM40	OBSOLETE	CFP	HFN	408		TBD	Call TI	Call TI	-55 to 125	5962-9678901QX C SMJ320MCM42DHF NM40	

(1) The marketing status values are defined as follows:

ACTIVE: Product device recommended for new designs.

LIFEBUY: TI has announced that the device will be discontinued, and a lifetime-buy period is in effect.

NRND: Not recommended for new designs. Device is in production to support existing customers, but TI does not recommend using this part in a new design.

PREVIEW: Device has been announced but is not in production. Samples may or may not be available.

OBSOLETE: TI has discontinued the production of the device.

(2) Eco Plan - The planned eco-friendly classification: Pb-Free (RoHS), Pb-Free (RoHS Exempt), or Green (RoHS & no Sb/Br) - please check <http://www.ti.com/productcontent> for the latest availability information and additional product content details.

TBD: The Pb-Free/Green conversion plan has not been defined.

Pb-Free (RoHS): TI's terms "Lead-Free" or "Pb-Free" mean semiconductor products that are compatible with the current RoHS requirements for all 6 substances, including the requirement that lead not exceed 0.1% by weight in homogeneous materials. Where designed to be soldered at high temperatures, TI Pb-Free products are suitable for use in specified lead-free processes.

Pb-Free (RoHS Exempt): This component has a RoHS exemption for either 1) lead-based flip-chip solder bumps used between the die and package, or 2) lead-based die adhesive used between the die and leadframe. The component is otherwise considered Pb-Free (RoHS compatible) as defined above.

Green (RoHS & no Sb/Br): TI defines "Green" to mean Pb-Free (RoHS compatible), and free of Bromine (Br) and Antimony (Sb) based flame retardants (Br or Sb do not exceed 0.1% by weight in homogeneous material)

(3) MSL, Peak Temp. - The Moisture Sensitivity Level rating according to the JEDEC industry standard classifications, and peak solder temperature.

(4) There may be additional marking, which relates to the logo, the lot trace code information, or the environmental category on the device.

(5) Multiple Device Markings will be inside parentheses. Only one Device Marking contained in parentheses and separated by a "~" will appear on a device. If a line is indented then it is a continuation of the previous line and the two combined represent the entire Device Marking for that device.

(6) Lead/Ball Finish - Orderable Devices may have multiple material finish options. Finish options are separated by a vertical ruled line. Lead/Ball Finish values may wrap to two lines if the finish value exceeds the maximum column width.

Important Information and Disclaimer: The information provided on this page represents TI's knowledge and belief as of the date that it is provided. TI bases its knowledge and belief on information provided by third parties, and makes no representation or warranty as to the accuracy of such information. Efforts are underway to better integrate information from third parties. TI has taken and continues to take reasonable steps to provide representative and accurate information but may not have conducted destructive testing or chemical analysis on incoming materials and chemicals. TI and TI suppliers consider certain information to be proprietary, and thus CAS numbers and other limited information may not be available for release.

In no event shall TI's liability arising out of such information exceed the total purchase price of the TI part(s) at issue in this document sold by TI to Customer on an annual basis.

HFN (S-CQFP-F408)

CERAMIC QUAD FLATPACK WITH TIE BAR

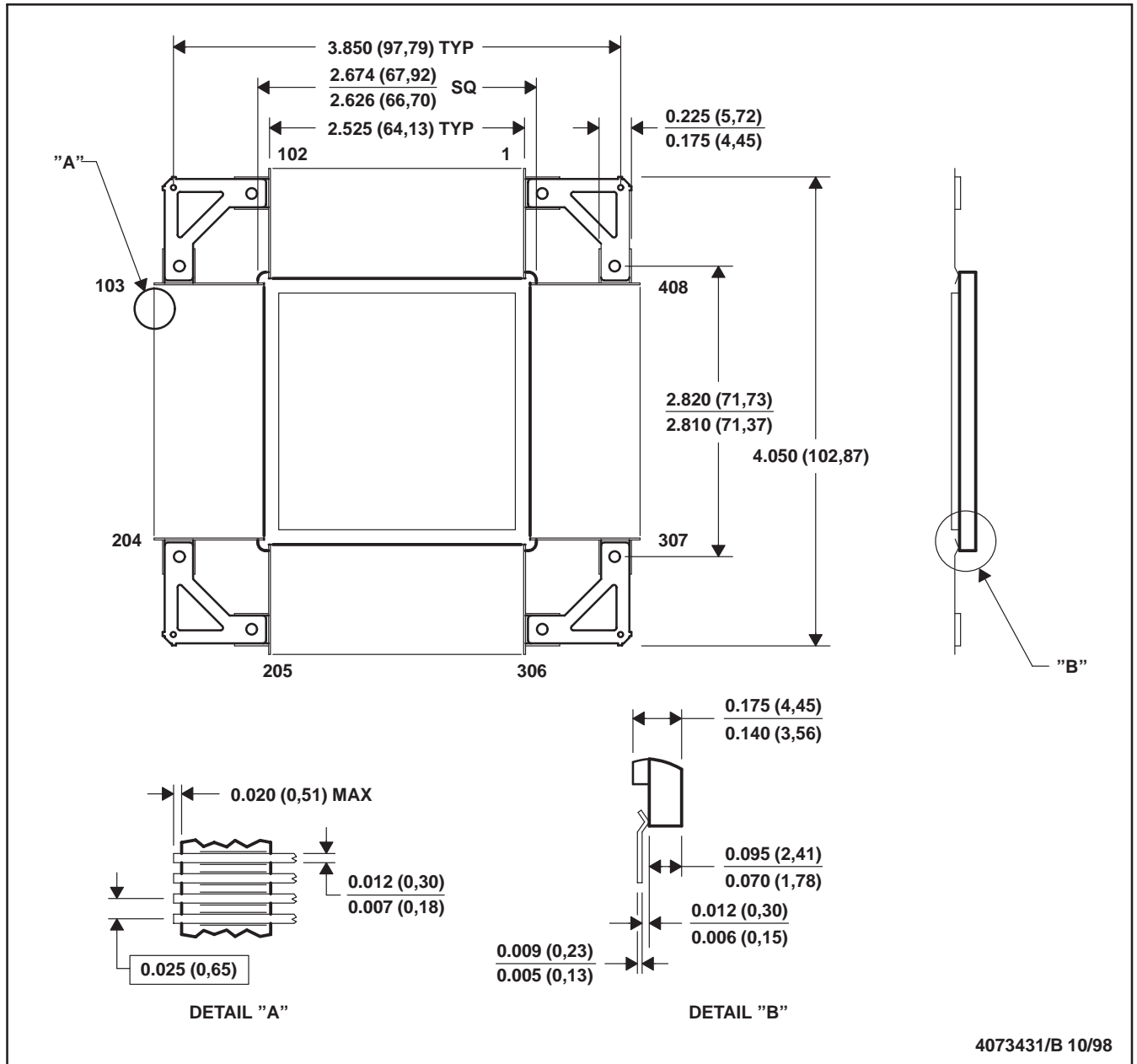

NOTES: A. All linear dimensions are in inches (millimeters).
 B. This drawing is subject to change without notice.

IMPORTANT NOTICE

Texas Instruments Incorporated and its subsidiaries (TI) reserve the right to make corrections, enhancements, improvements and other changes to its semiconductor products and services per JESD46, latest issue, and to discontinue any product or service per JESD48, latest issue. Buyers should obtain the latest relevant information before placing orders and should verify that such information is current and complete. All semiconductor products (also referred to herein as "components") are sold subject to TI's terms and conditions of sale supplied at the time of order acknowledgment.

TI warrants performance of its components to the specifications applicable at the time of sale, in accordance with the warranty in TI's terms and conditions of sale of semiconductor products. Testing and other quality control techniques are used to the extent TI deems necessary to support this warranty. Except where mandated by applicable law, testing of all parameters of each component is not necessarily performed.

TI assumes no liability for applications assistance or the design of Buyers' products. Buyers are responsible for their products and applications using TI components. To minimize the risks associated with Buyers' products and applications, Buyers should provide adequate design and operating safeguards.

TI does not warrant or represent that any license, either express or implied, is granted under any patent right, copyright, mask work right, or other intellectual property right relating to any combination, machine, or process in which TI components or services are used. Information published by TI regarding third-party products or services does not constitute a license to use such products or services or a warranty or endorsement thereof. Use of such information may require a license from a third party under the patents or other intellectual property of the third party, or a license from TI under the patents or other intellectual property of TI.

Reproduction of significant portions of TI information in TI data books or data sheets is permissible only if reproduction is without alteration and is accompanied by all associated warranties, conditions, limitations, and notices. TI is not responsible or liable for such altered documentation. Information of third parties may be subject to additional restrictions.

Resale of TI components or services with statements different from or beyond the parameters stated by TI for that component or service voids all express and any implied warranties for the associated TI component or service and is an unfair and deceptive business practice. TI is not responsible or liable for any such statements.

Buyer acknowledges and agrees that it is solely responsible for compliance with all legal, regulatory and safety-related requirements concerning its products, and any use of TI components in its applications, notwithstanding any applications-related information or support that may be provided by TI. Buyer represents and agrees that it has all the necessary expertise to create and implement safeguards which anticipate dangerous consequences of failures, monitor failures and their consequences, lessen the likelihood of failures that might cause harm and take appropriate remedial actions. Buyer will fully indemnify TI and its representatives against any damages arising out of the use of any TI components in safety-critical applications.

In some cases, TI components may be promoted specifically to facilitate safety-related applications. With such components, TI's goal is to help enable customers to design and create their own end-product solutions that meet applicable functional safety standards and requirements. Nonetheless, such components are subject to these terms.

No TI components are authorized for use in FDA Class III (or similar life-critical medical equipment) unless authorized officers of the parties have executed a special agreement specifically governing such use.

Only those TI components which TI has specifically designated as military grade or "enhanced plastic" are designed and intended for use in military/aerospace applications or environments. Buyer acknowledges and agrees that any military or aerospace use of TI components which have **not** been so designated is solely at the Buyer's risk, and that Buyer is solely responsible for compliance with all legal and regulatory requirements in connection with such use.

TI has specifically designated certain components as meeting ISO/TS16949 requirements, mainly for automotive use. In any case of use of non-designated products, TI will not be responsible for any failure to meet ISO/TS16949.

Products

Audio	www.ti.com/audio
Amplifiers	amplifier.ti.com
Data Converters	dataconverter.ti.com
DLP® Products	www.dlp.com
DSP	dsp.ti.com
Clocks and Timers	www.ti.com/clocks
Interface	interface.ti.com
Logic	logic.ti.com
Power Mgmt	power.ti.com
Microcontrollers	microcontroller.ti.com
RFID	www.ti-rfid.com
OMAP Applications Processors	www.ti.com/omap
Wireless Connectivity	www.ti.com/wirelessconnectivity

Applications

Automotive and Transportation	www.ti.com/automotive
Communications and Telecom	www.ti.com/communications
Computers and Peripherals	www.ti.com/computers
Consumer Electronics	www.ti.com/consumer-apps
Energy and Lighting	www.ti.com/energy
Industrial	www.ti.com/industrial
Medical	www.ti.com/medical
Security	www.ti.com/security
Space, Avionics and Defense	www.ti.com/space-avionics-defense
Video and Imaging	www.ti.com/video

TI E2E Community

e2e.ti.com