

Standard Products VRG8601 / 2 / 3 / 4 Rad Hard Dual Adjustable Positive & Negative Voltage Regulator

www.aeroflex.com/RadHard

June 21, 2007



Common Features

- ❑ Radiation Total Dose
 - 100KRad - VRG8601/2
 - 30KRad - VRG8603/4
- ❑ 1.5A output current
- ❑ Current limited
- ❑ Line regulation .01% typ
- ❑ Output short circuit protected
- ❑ Thermal Shutdown
- ❑ Packaging – Hermetic Metal
 - Thru-Hole or Surface Mount
 - 6 Leads, .65" x .42" x .200"
 - Power Package
 - Weight - 5 gm max
- ❑ Military and Space Temperature Range
- ❑ DESC SMD: 5962-05219 approved

Positive Regulator Features

- ❑ Output voltage adjustable from 1.2V to 37V
- ❑ Load regulation 0.1% typ
- ❑ Ripple rejection 80dB typ

Negative Regulator Features

- ❑ Output voltage adjustable range
 - VRG8601/2 -1.2V to -27V
 - VRG8603/4 -1.2V to -37V
- ❑ Load regulation 0.3% typ
- ❑ Ripple rejection 77dB typ

NOTE: Aeroflex Plainview does not currently have a DSCC certified Radiation Hardened Assurance Program

DESCRIPTION

The positive (RH117) and a negative (RH137) voltage regulator are capable of supplying in excess of 1.5Amps over the output voltage range as defined under recommended operating conditions. Each regulator is exceptionally easy to set-up, requiring only 2 external resistors to set the output voltage. The module design has been optimized for excellent regulation and low thermal transients. There is full electrical isolation between positive and negative regulators and each to the package.

Further, the VRG8601/2/3/4 features internal current limiting, thermal shutdown and safe-area compensation, making them virtually blowout-proof against overloads. The VRG8601/2/3/4 serves a wide variety of applications including local on-card regulation, programmable output voltage regulation or precision current regulation.

The VRG8601/2/3/4 has been specifically designed to meet exposure to radiation environments. The VRG8601/3 is configured for a Thru-Hole 6 lead metal power package and the VRG8602/4 is configured for a Surface Mount 6 lead metal power package. It is guaranteed operational from -55°C to +125°C. Available screened to MIL-STD-883, the VRG8601/2/3/4 is ideal for demanding military and space applications.

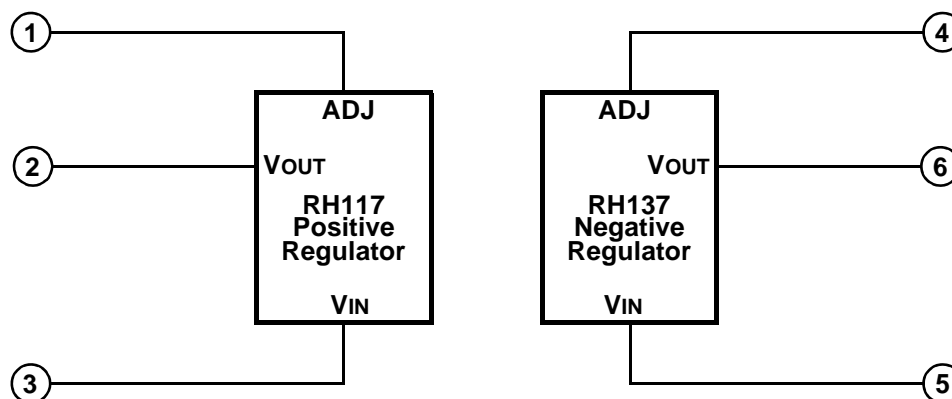

BLOCK DIAGRAM / SCHEMATIC

ABSOLUTE MAXIMUM RATINGS

PARAMETER	RANGE		UNITS
	VRG8601/2	VRG8603/4	
Operating (Junction) Temperature Range	-55 to +150		°C
Lead Temperature (soldering, 10 sec)	300		°C
Storage Temperature Range	-65 to +150		°C
Input-Output Voltage Differential	40 (Pos) 30 (Neg)	40	V
Thermal Resistance (junction to case Θ_{JC}) each, Pos. & Neg.	5		°C/W
ESD Rating	1.999 ^{1/}	TBD	KV

^{1/} Meets ESD testing per MIL-STD-883, method 3015, Class 1C.

NOTICE: Stresses above those listed under "Absolute Maximums Rating" may cause permanent damage to the device. These are stress rating only; functional operation beyond the "Operation Conditions" is not recommended and extended exposure beyond the "Operation Conditions" may effect device reliability.

RECOMMENDED OPERATING CONDITIONS

PARAMETER	RANGE		UNITS
	VRG8601/2	VRG8603/4	
Output Voltage Range Positive Voltage Regulator	1.2 to 37		VDC
Negative Voltage Regulator	-1.2 to -22	-1.2 to -37	VDC
Case Operating Temperature Range	-55 to +125		°C

POSITIVE REGULATOR – ELECTRICAL PERFORMANCE CHARACTERISTICS ^{1/}

PARAMETER	SYM	CONDITIONS	VRG8601/2		VRG8603/4		UNITS
			MIN	MAX	MIN	MAX	
Reference Voltage	V _{REF}	$3V \leq (V_{IN} - V_{OUT}) \leq V_{DIFF\ MAX}$, $10mA \leq I_{OUT} \leq I_{MAX}$	1.20	1.30	1.20	1.30	V
Line Regulation ^{2/}	$\frac{\Delta V_{OUT}}{\Delta V_{IN}}$	$3V \leq (V_{IN} - V_{OUT}) \leq V_{DIFF\ MAX}$, $I_{OUT} = 10mA$	-	0.02	-	0.05	%/V
Load Regulation ^{2/}	$\frac{\Delta V_{OUT}}{\Delta I_{OUT}}$	$10mA \leq I_{OUT} \leq I_{MAX}$, $V_{OUT} \leq 5V$ $10mA \leq I_{OUT} \leq I_{MAX}$, $V_{OUT} \geq 5V$	-	15 0.3	-	15 1	mV %
Thermal Regulation		$I_{OUT} = 1.5A$, $(V_{IN} - V_{OUT}) = 13.3V$, 20ms Pulse, 20W	-	0.07	-	0.07	%/W
Ripple Rejection Ratio		$V_{OUT} = 10V$, $f = 120Hz$, $C_{ADJ} = 10\mu F$	66	-	66	-	dB
Adjustment Pin Current	I _{ADJ}		-	100	-	100	μA
Adjustment Pin Current Change	ΔI_{ADJ}	$10mA \leq I_{OUT} \leq I_{MAX}$	-	5	-	5	μA
		$3.0V \leq (V_{IN} - V_{OUT}) \leq 40V$, $I_{OUT} = 10mA$	-	5	-	5	μA
Minimum Load Current ^{3/}	I _{MIN}	$(V_{IN} - V_{OUT}) = 40V$	-	5	-	5	mA
Current Limit	I _{MAX}	$(V_{IN} - V_{OUT}) \leq 15V$	1.5	-	1.5	-	A
		$(V_{IN} - V_{OUT}) = 40V$, $T_C = +25^\circ C$	0.30	-	0.30	-	
Long Term Stability ^{3/}	$\frac{\Delta V_{OUT}}{\Delta TIME}$	$T_A = +125^\circ C$	-	1	-	1	%
Thermal Resistance, each Regulator (Junction to Case) ^{3/}	Θ_{JC}		-	5	-	5	°C/W

NEGATIVE REGULATOR – ELECTRICAL PERFORMANCE CHARACTERISTICS 1/

PARAMETER	SYM	CONDITIONS	VRG8601/2		VRG8603/4		UNITS
			MIN	MAX	MIN	MAX	
Reference Voltage	VREF	$3V \leq (V_{IN} - V_{OUT}) \leq V_{DIFF\ MAX}$ $10mA \leq I_{OUT} \leq I_{MAX}$	-1.200	-1.300	-1.200	-1.300	V
Line Regulation 2/	$\frac{\Delta V_{OUT}}{\Delta V_{IN}}$	$3V \leq (V_{IN} - V_{OUT}) \leq 30V,$	-	0.02	-	-	% / V
		$3V \leq (V_{IN} - V_{OUT}) \leq 40V,$	-	-	-	0.05	
Load Regulation 2/	$\frac{\Delta V_{OUT}}{\Delta I_{OUT}}$	$10mA \leq I_{OUT} \leq I_{MAX}, V_{OUT} \leq 5V$	-	25	-	25	mV
		$10mA \leq I_{OUT} \leq I_{MAX}, V_{OUT} \geq 5V$	-	0.5	-	1	%
Thermal Regulation		$I_{OUT} = 1.5A, (V_{IN} - V_{OUT}) = 13.3V,$ 20ms Pulse, 20W	-	0.02	-	0.02	% / W
Ripple Rejection		$V_{OUT} = -10V, f = 120Hz,$ CADJ = 10 μ F	66	-	66	-	dB
Adjustment Pin Current	IADJ		-	100	-	100	μ A
Adjustment Pin Current Change	ΔI_{ADJ}	$10mA \leq I_{OUT} \leq I_{MAX}$	-	5	-	5	
		$3V \leq (V_{IN} - V_{OUT}) \leq 30V$	-	5	-	-	
Minimum Load Current 3/	I _{MIN}	$(V_{IN} - V_{OUT}) = 30V$	-	5	-	-	mA
		$(V_{IN} - V_{OUT}) \leq 10V$	-	3	-	3	
		$(V_{IN} - V_{OUT}) = 40V$	-	-	-	5	
Current Limit	I _{MAX}	$(V_{IN} - V_{OUT}) \leq 15V$	1.5	-	1.5	-	A
		$(V_{IN} - V_{OUT}) = 30V, T_c = +25^\circ C$	0.24	-	-	-	
		$(V_{IN} - V_{OUT}) = 40V, T_c = +25^\circ C$	-	-	0.24	-	
Long Term Stability 3/	$\frac{\Delta V_{OUT}}{\Delta TIME}$	$T_A = +125^\circ C$	-	1	-	1	%
Thermal Resistance, each Regulator (Junction to Case) 3/	Θ_{JC}		-	5	-	5	$^\circ C / W$

Notes:

1. Unless otherwise specified, these specifications apply for post radiation, $(V_{in} - V_{out}) = 5V, I_{out} = 0.5A$ and $-55^\circ C < T_c < +125^\circ C$.
2. Regulation is measured at a constant junction temperature, using pulse testing with a low duty cycle. Changes in output voltage due to heating effects are covered under the specification for thermal regulation. Measurements taken at the output lead must be adjusted for lead resistance.
3. Not tested. Shall be guaranteed to the specified limits.

MAXIMUM POWER vs CASE TEMPERATURE

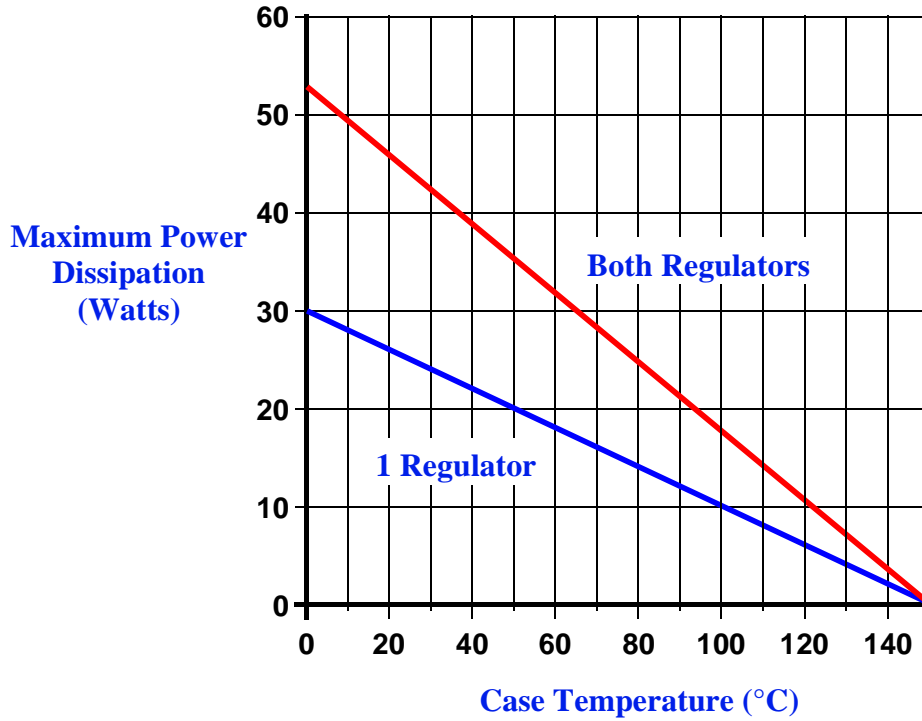

The maximum Power dissipation is limited by the thermal shutdown function of each regulator chip in the VRG860X. The graph above represents the achievable power before the chip shuts down. The first line in the graph represents the maximum power dissipation of the VRG860X with one regulator on (the other off) and the other line represents both regulators on dissipating equal power. If both regulators are on and one regulator is dissipating more power than the other, the maximum power dissipation of the VRG860X will fall between the two lines. This graph is based on the maximum junction temperature of 150°C and a thermal resistance (Θ_{JC}) of 5°C/W.

TYPICAL APPLICATIONS

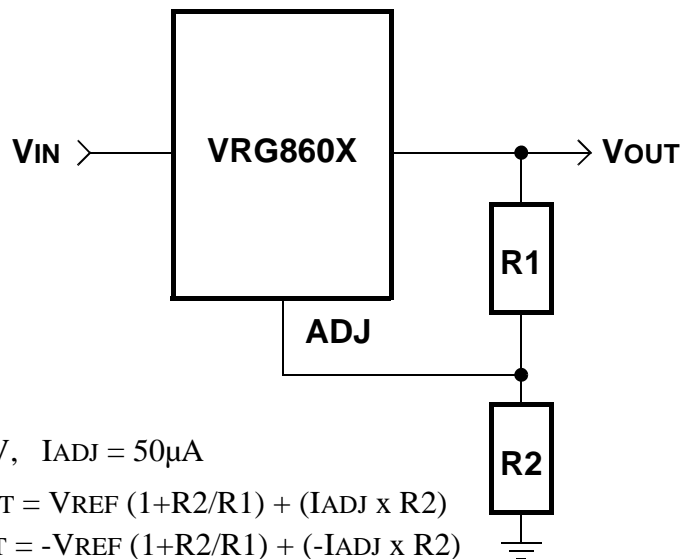

Adjustable Regulator

PACKAGE OUTLINE — THRU-HOLE POWER PACKAGE

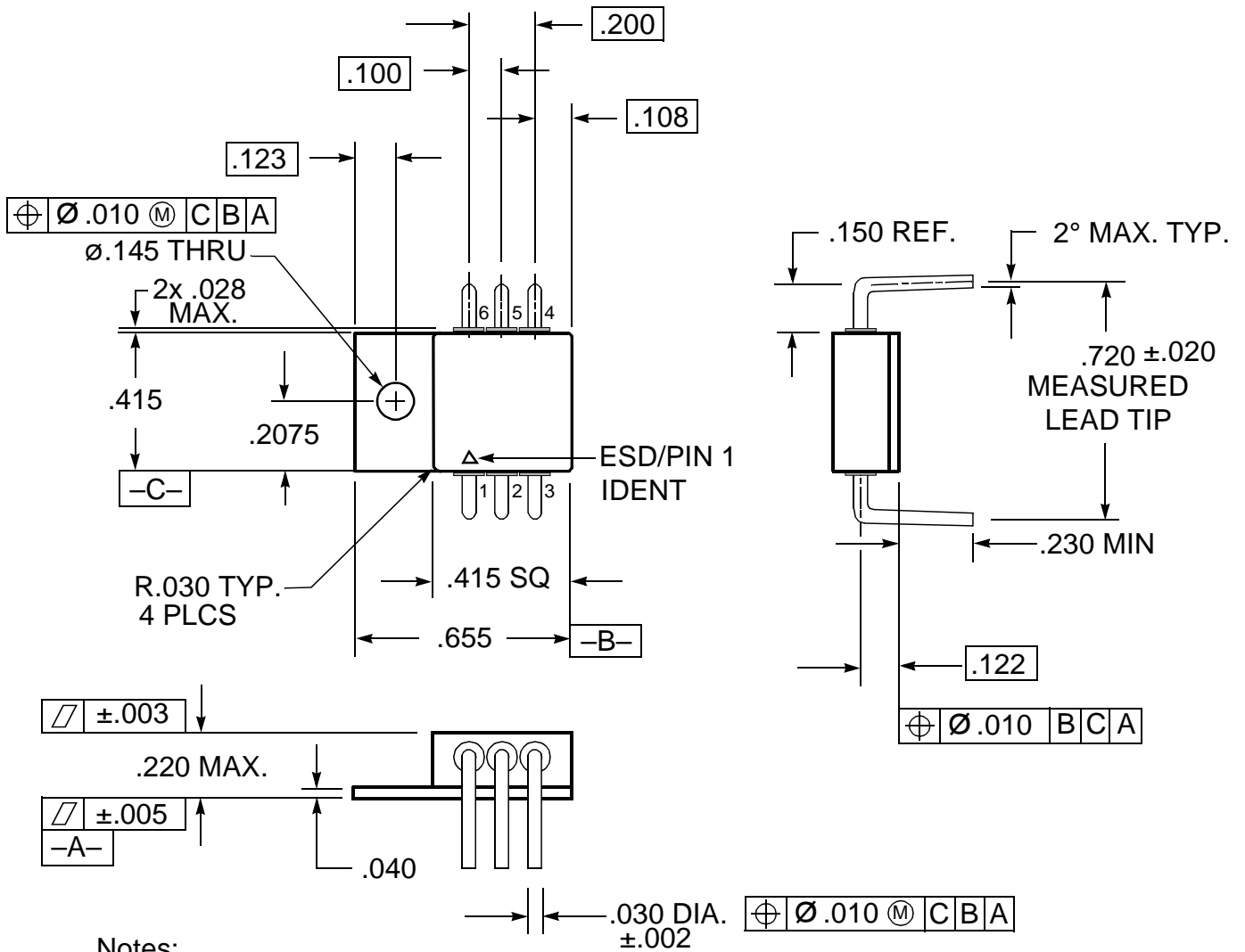

PIN NUMBERS vs FUNCTION

PIN	FUNCTION
1	Positive ADJ
2	Positive VOUT
3	Positive VIN
4	Negative ADJ
5	Negative VIN
6	Negative VOUT

PACKAGE OUTLINE — SURFACE MOUNT POWER PACKAGE

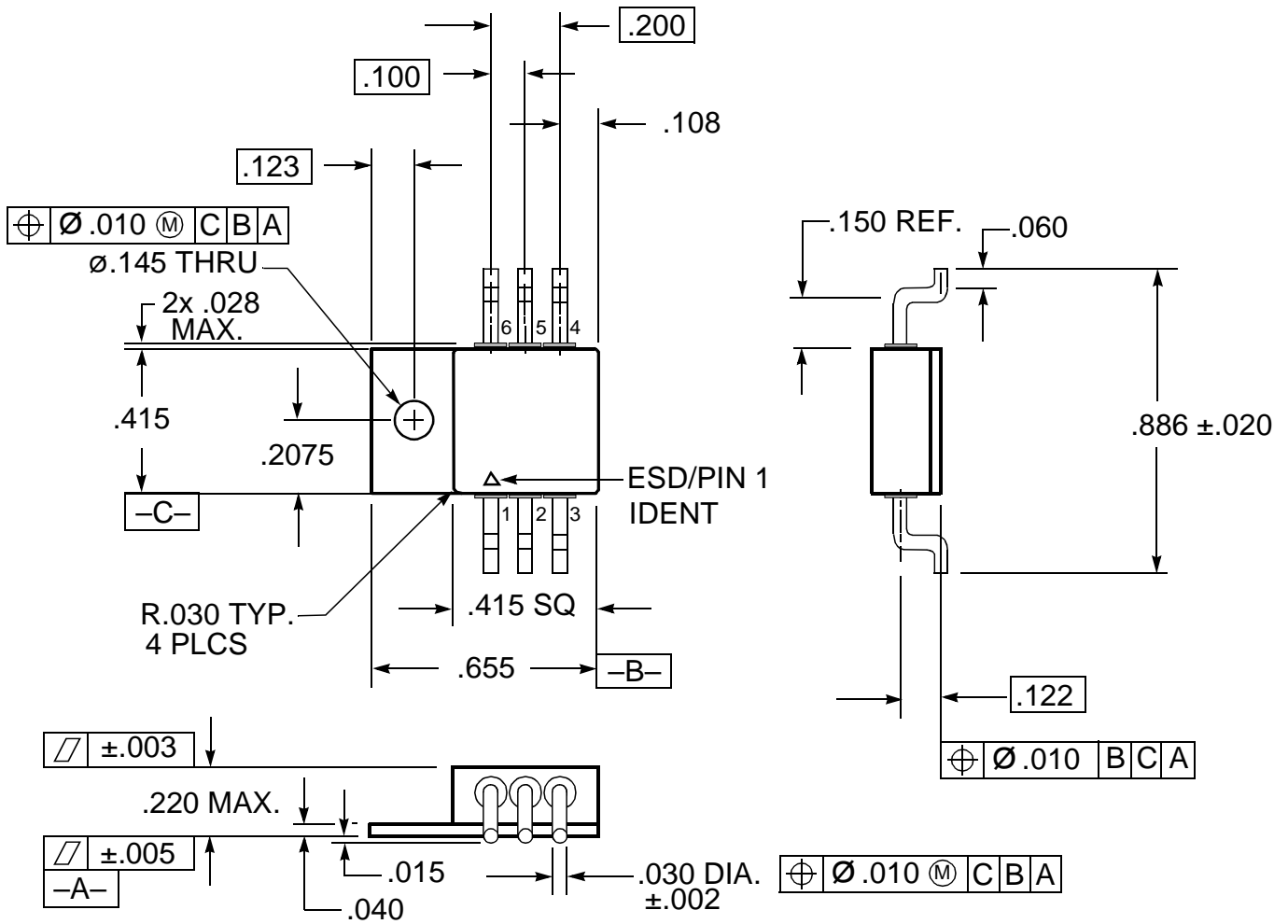

Notes:

1. Dimension Tolerance: $\pm .005$ inches
2. Package contains BeO substrate
3. Case electrically isolated

PIN NUMBERS vs FUNCTION

PIN	FUNCTION
1	Positive ADJ
2	Positive VOUT
3	Positive VIN
4	Negative ADJ
5	Negative VIN
6	Negative VOUT

ORDERING INFORMATION

MODEL	DESC SMD #	SCREENING	PACKAGE
VGR8601-201-XS VGR8603-201-XS	5962-0521901KXX 5962-0521902KXX	DSCC SMD 5962-05219	6 Lead Thru-Hole Power Pkg
VGR8602-201-XS VGR8604-201-XS	5962-0521901KYX 5962-0521902KYX		6 Lead Surface Mount Power Pkg
VRG8601-S	-	Military Temperature, -55°C to +125°C, Screened to the individual test methods of MIL-STD-883.	6 Lead Thru-Hole Power Pkg
VRG8601-7		Commercial Flow, +25°C testing only	
VRG8602-S		Military Temperature, -55°C to +125°C, Screened to the individual test methods of MIL-STD-883.	6 Lead Surface Mount Power Pkg
VRG8602-7		Commercial Flow, +25°C testing only	
VRG8603-S		Military Temperature, -55°C to +125°C, Screened to the individual test methods of MIL-STD-883.	6 Lead Thru-Hole Power Pkg
VRG8603-7		Commercial Flow, +25°C testing only	
VRG8604-S		Military Temperature, -55°C to +125°C, Screened to the individual test methods of MIL-STD-883.	6 Lead Surface Mount Power Pkg
VRG8604-7		Commercial Flow, +25°C testing only	

PLAINVIEW, NEW YORK

Toll Free: 800-THE-1553
Fax: 516-694-6715

INTERNATIONAL

Tel: 805-778-9229
Fax: 805-778-1980

NORTHEAST

Tel: 603-888-3975
Fax: 603-888-4585

SE AND MID-ATLANTIC

Tel: 321-951-4164
Fax: 321-951-4254

WEST COAST

Tel: 949-362-2260
Fax: 949-362-2266

CENTRAL

Tel: 719-594-8017
Fax: 719-594-8468

www.aeroflex.com info-ams@aeroflex.com



Aeroflex Microelectronic Solutions reserves the right to change at any time without notice the specifications, design, function, or form of its products described herein. All parameters must be validated for each customer's application by engineering. No liability is assumed as a result of use of this product. No patent licenses are implied.



Our passion for performance is defined by three attributes represented by these three icons: solution-minded, performance-driven and customer-focused