

# Agilent HPMX-7123 Single-Band Downconverter Optimized for 1900 MHz PCS Applications Data Sheet

## General Description

The HPMX-7123 downconverter, part of the **CDMAdvantage** RF chipset, offers a highly integrated solution for PCS handsets. This integrated solution leads to improvement in cost and reliability. The HPMX-7123 has a high IP3 which is highly desirable for CDMA high dynamic range receivers with good noise and spurious suppression.

The chip is comprised of an RF input LNA followed by a wideband mixer. The output of the downconverter is differential providing common mode rejection. The outputs are high impedance open collectors.

HPMX-7123 features a current control through a DC voltage,  $V_{cs}$ , to accommodate varying linearity requirements. If used dynamically, current control reduces the overall current consumption

maximizing battery life. In addition input linearity can be increased by adding inductance to the combined pin 2 and pin 3.

The IC is housed in a miniature BCC-16 package and manufactured on high frequency, low noise Si-Bipolar process (25 GHz Ft).

## Plastic Package, BCC-16

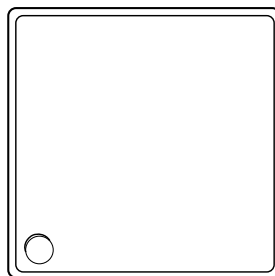

## Features

- **Wide band operation**  
RF input: 0.4 – 2.4 GHz  
IF output: 50 – 400 MHz
- **High conversion gain (14 dB)**
- **2.7 – 5.0 V operation**
- **Low & adjustable current: 6 – 18 mA**
- **Differential IF outputs**
- **Adjustable IP3 (20 dBm OIP3)**
- **Standard BCC-16 surface mount package**

## Applications

- **PCS handsets**
- **Wireless data terminals**
- **Wireless LAN (802.11)**

## Functional Block Diagram

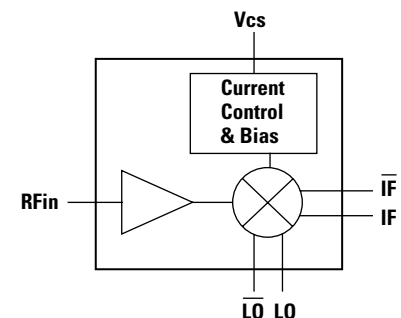

For optimal performance, differential LO drive is recommended.



## HPMX-7123 Absolute Maximum Ratings<sup>[1]</sup>

Parameter	Units	Absolute Maximum
V <sub>cc</sub> Supply Voltage	Volt	5
Control Voltage	Volt	V <sub>cc</sub> + 0.5
Input RF Power	dBm	5
LO Input Power	dBm	7
Case Temperature	°C	125
Storage Temperature	°C	150

Recommended operating range of V<sub>cc</sub> = 2.7 to 3.6 V, T<sub>a</sub> = -40 to +85°C.

### Note:

1. Operation of this device in excess of any of these limits may cause permanent damage.

## HPMX-7123 Standard Test Conditions

Unless otherwise stated, all test data was taken on packaged parts under the following conditions:

V<sub>cc</sub> = +3.0 V, T<sub>ambient</sub> = 25°C, V<sub>cs</sub> = 3 V (I<sub>cc</sub> = 17 mA)

LO input: 1750 MHz, -3 dBm, single-ended

RF input: 1960 MHz, -33 dBm, single-ended

Z<sub>inmixer</sub> = 50Ω, Z<sub>out</sub> = 500Ω differential (See Figure 4 for test set-up schematic diagram)

## HPMX-7123 Summary Characterization Information

Standard test conditions apply unless otherwise noted.

Symbol	Parameters and Test Conditions	V <sub>cs</sub>	PCS			Units
			Min.	Typ.	Max.	
I <sub>cc</sub>	Supply Current	3 V		17		mA
		2.5 V		14		
		1.5 V		8		
G <sub>c</sub>	Conversion Gain	3 V	12.5	14		dB
		1.5 V		12		
NF (SSB)	Noise Figure	3 V		10	11.5	dB
		1.5 V		7		
IIP3	Input Third Order Intercept	3 V		6		dBm
		1.5 V		1		
OIP3	Output Third Order Intercept	3 V		20		dBm
		1.5 V		13		
RL (RF)	RF port Return Loss <sup>[1]</sup>			>10		dB
RL (IF)	IF port Return Loss <sup>[1]</sup>			>10		dB
RL (LO)	LO port Return Loss <sup>[2]</sup>			>10		dB

### Notes:

1. Externally matched
2. LO-Balun 4:1

### HPMX-7123 BCC-16 Package: Pin Description Table

No.	Mnemonic	Description	Typical Signal
1	RFin	Single-ended RF input	RF signal
2	LGnd	Inductor/Ground	
3	LGnd	Inductor/Ground	
4	Vcs	Current/Linearity control input	DC voltage source
5	Open	Open	
6	Gnd	Ground	
7	Open	Open	
8	LObar	Differential LO input	RF signal
9	Open	Open	
10	LO	Differential LO input	RF signal
11	IFbar	Differential IF output	IF output signal
12	IF	Differential IF output	IF output signal
13	Open	Open	
14	Vcc	IC Vcc input	DC voltage source
15	Open	Open	
16	Open	Open	

### HPMX-7123 Package Marking and Pin Reference

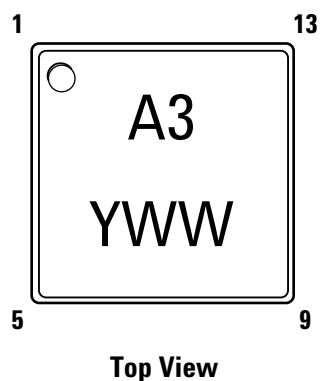

### HPMX-7123 Characterization Graphs

Measurements taken at the following conditions, unless noted otherwise:  $V_{cc} = 3V$ ,  $V_{cs} = 3V$ , LO frequency = 1750 MHz (-3 dB), 25°C

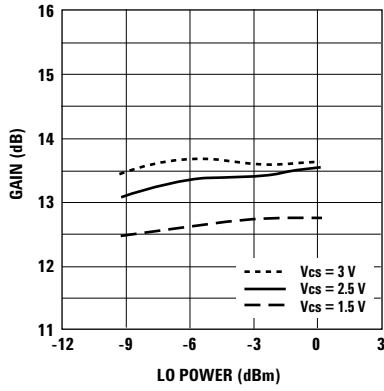

Figure 1. Gain vs. LO Power.

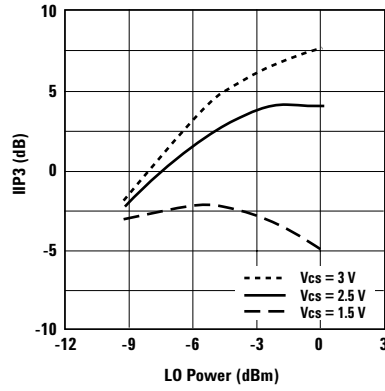

Figure 2. IIP3 vs. LO Power.

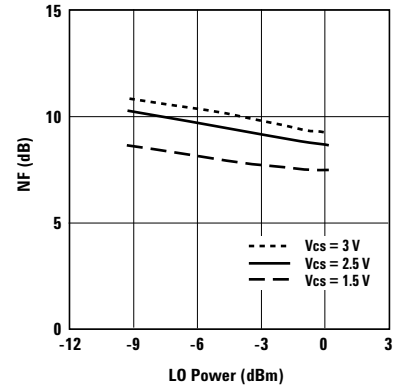

Figure 3. NF vs. LO Power .

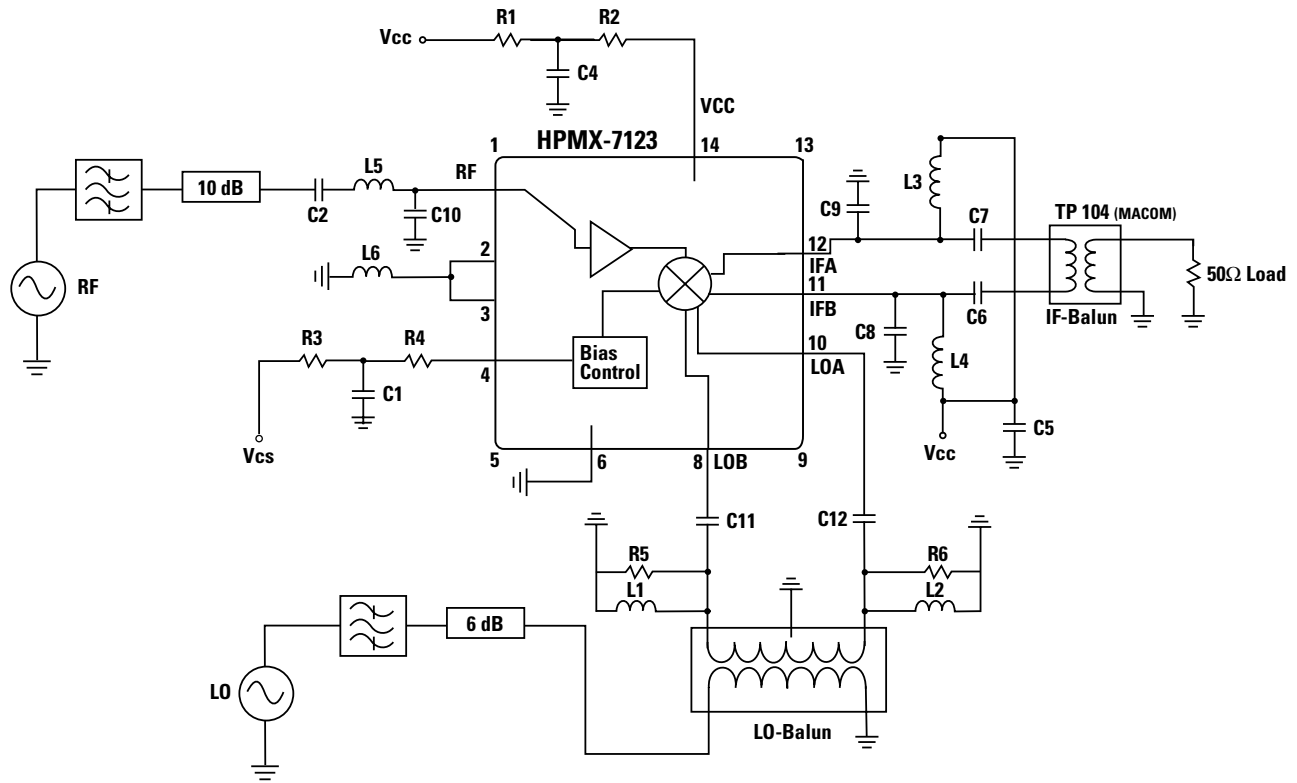

Figure 4. HPMX-7123 Test Diagram for the PCS Applications.

Board Designation	Component	Package
HPMX-7123	Device under test	BCC-16
LO-Balun	LDB20C 201A 1900	MURATA
IF-Balun	TP 104	M/A-COM
C1, 4, 5, 11, 12	1000 pF	CAP 0402
C2	100 pF	CAP 0402
C6, 7	4.7 pF	CAP 0402
C8, 9	1 pF	CAP 0402
C10	Open	CAP 0402
L1, 2	2.7 nH	IND 0402 TOKO
L3, 4	39 nH	IND 0402 TOKO
L5	0 nH	IND 0402 TOKO
L6	0 nH	IND 0402 TOKO
R1, 2	2.7Ω	RES 0402
R3, 4	50Ω	RES 0402
R5, 6	100Ω	RES 0402

### Part Number Ordering Information

Part Number	No. of Devices	Container
HPMX-7123-BLK	10	Bulk
HPMX-7123-TR1	1000	7" Tape and Reel

### Package Dimensions Standard BCC-16 Package

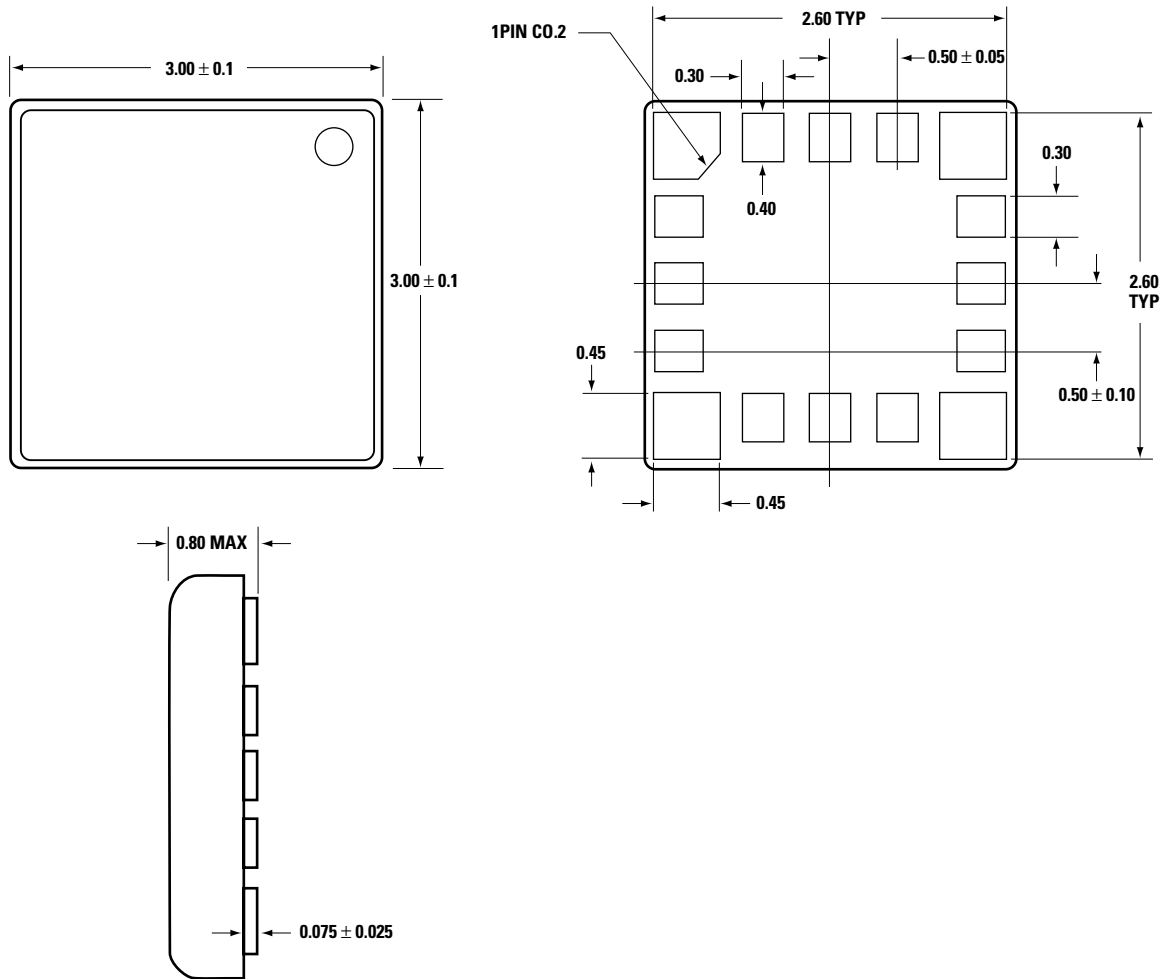

All units in millimeters (mm)

*www.semiconductor.agilent.com*

Data subject to change.

Copyright © 2001 Agilent Technologies, Inc.

June 20, 2001

5988-2008EN



**Agilent Technologies**